

SPARE PARTS MANUAL

FLEXTOOL SUBMERSIBLE PUMPS FP212G, FP212A, FP212C



Applies to product from Serial Number D07-10000

Version 4.0 (October 2023)

Pump Head – Complete Assembly (All Types)

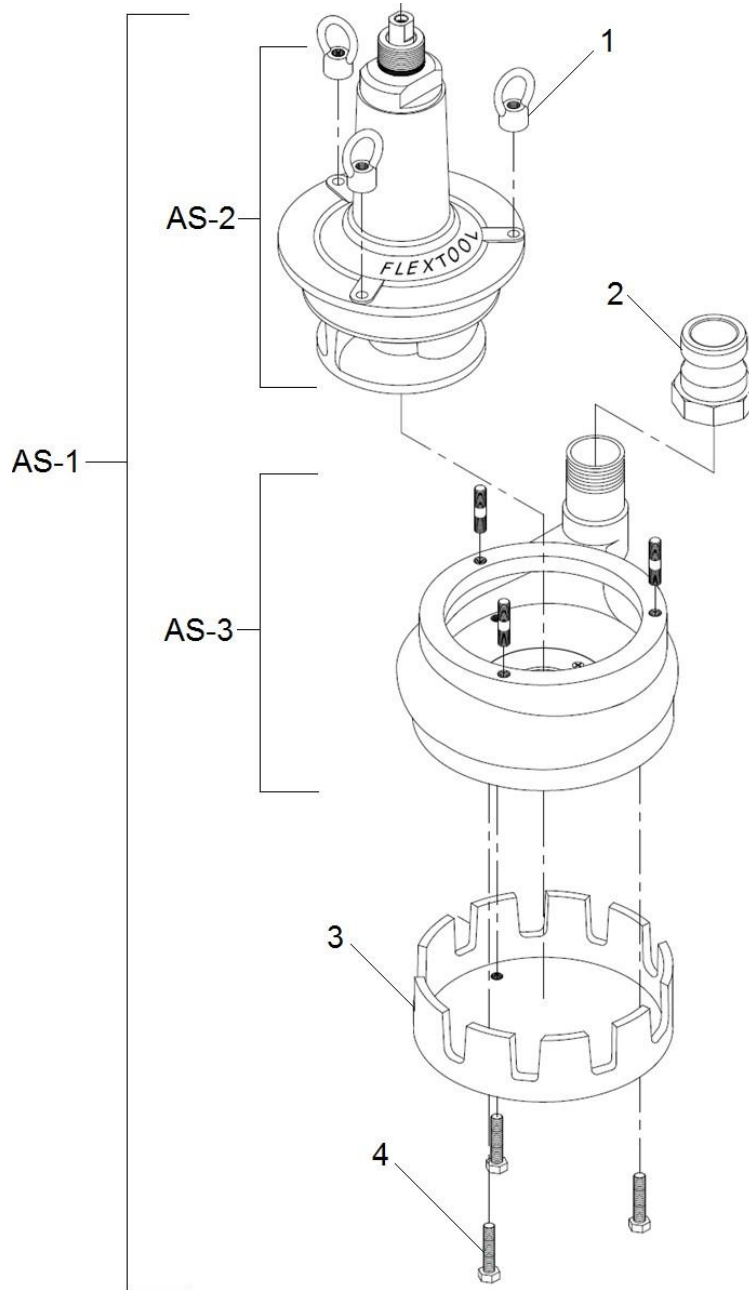

Pump Head (All Types)

Item No.	Product Code	Description	Qty	Remarks
1	NPS06170-UNIT	FLX EYE NUT 0.375" BSW (610510)	3	
2	NPS07469-UNIT	FLX CAMLOCK ADAPTOR 50MM (206308)	1	Suits FP212G & FP212A Only
3	NPS06169-UNIT	FLX STRAINER ALUMINIUM (206311)	1	Suits FP212G & FP212A
	NPS09522-UNIT	FLX STRAINER CAST IRON (206321)	1	Suits FP212C
4	NPS06902-UNIT	FLX BOLT 0.375" BSW x 2.5" (590425)	3	

Assembly / Service Kits - Pumps Head (All Types)

Item No.	Product Code	Description	Qty	Remarks
AS-1	NPS06127-UNIT	FLX ASSY PUMP HEAD GENERAL (206300)	1	Suits FP212G (General Purpose)
	NPS08495-UNIT	FLX ASSY PUMP HEAD ABRAISIVE (206300PA)	1	Suits FP212A (Abrasion Resistant)
	NPS09701-UNIT	FLX ASSY PUMP HEAD CHEMICAL (206300PC)	1	Suits FP212C (Chemical Resistant)
AS-2	NPS08498-UNIT	FLX ASSY PUMP HEAD TOP ALUMINIUM (206390)	1	Suits FP212G & F P212A
	NPS01585-UNIT	FLX ASSY PUMP HEAD TOP CAST IRON (206391)	1	Suits FP212C
AS-3	NPS06255-UNIT	FLX ASSY PUMP BODY ALUMINIUM (206380)	1	Suits FP212G
	NPS08496-UNIT	FLX ASSY PUMP BODY CAST IRON (206381)	1	Suits FP212A & FP212C

Pump Head – Top Assy (All Types)

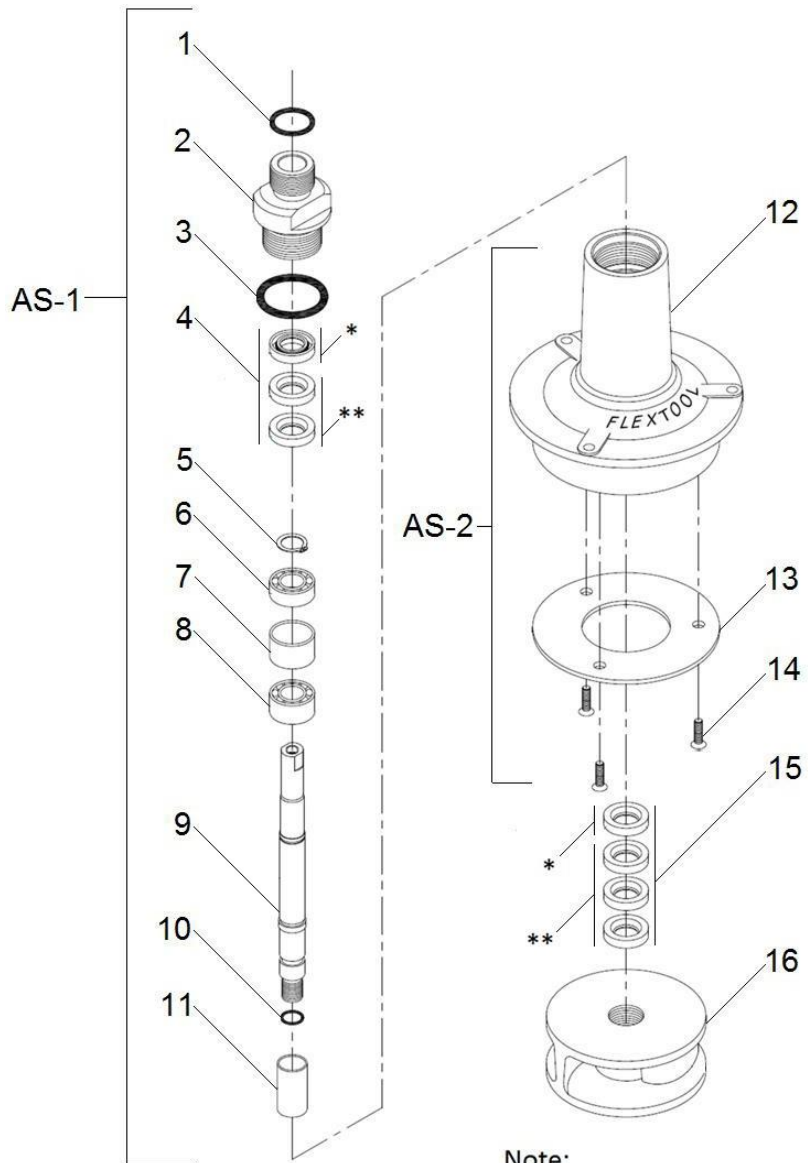

Note:

* Seal - Spring faces upwards

** Seal - Spring faces downwards

Pump Head – Top Assy (All Types)

Item No.	Product Code	Description	Qty	Remarks
1	See Remarks	FLX O-RING 1.049" x 0.103" (510433)	1	Use SK-1
2	NPS06131-UNIT	FLX HOUSING ADAPTOR (206301)	1	
3	See Remarks	FLX O-RING 1.687" x 0.139" (510434)	1	Use SK-1
4	See Remarks	FLX SEAL 0.75" x 1.25" x 0.25" (530111)	3	Use SK-1
5	See Remarks	FLX CIRCLIP EXTERNAL 20MM (670211)	1	Use SK-1
6	See Remarks	FLX BEARING NSK 6204 (550501)	1	Use SK-1
7	See Remarks	FLX SPACER (206302)	1	Use SK-1
8	See Remarks	FLX BEARING NACHI 5204 (550559)	1	Use SK-1
9	NPS08489-UNIT	FLX SPINDLE (206303)	1	
10	See Remarks	FLX O-RING 0.626" x 0.103" (510435)	1	Use SK-1
11	See Remarks	FLX SLEEVE (206304)	1	Use SK-1
12	See Remarks	FLX HOUSING ALUMINIUM (206305)	1	Use AS-2 (Suits FP212G & FP212A)
	See Remarks	FLX HOUSING CAST IRON (206315)	1	Use AS-2 (Suits P212C)
13	See Remarks	FLX WEAR PLATE (206306)	1	Use AS-2
14	See Remarks	FLX SCREW CSK M6X12 (633509)	3	Use AS-2
15	See Remarks	FLX SEAL 1" x 1.625" x 0.375" (530510)	4	Use SK-1
16	NPS06476-UNIT	FLX IMPELLER CAST IRON (206307)	1	

Assembly / Service Kits - Pumps Head Top Assy (All Types)

Item No.	Product Code	Description	Qty	Remarks
AS-1	NPS08498-UNIT	FLX ASSY PUMP HEAD TOP ALUMINIUM (206390)	1	Suits FP212G & FP212A
	NPS01585-UNIT	FLX ASSY PUMP HEAD TOP CAST IRON (206391)	1	Suits FP212C
AS-2	NPS06128-UNIT	FLX ASSY HOUSING ALUMINIUM (206392)	1	Suits FP212G & FP212A Inc Items: 12 - 14
	NPS02229-UNIT	FLX ASSY HOUSING CAST IRON (206393)	1	Suit: P212C Inc Items: 12 - 14
SK-1	NPS08541-UNIT	FLX SERVICE KIT PUMP HEAD (206946SK)	1	Inc Items: 1, 3 - 8, 10, 11, 15

Pump Head – Body Assy (All Types)

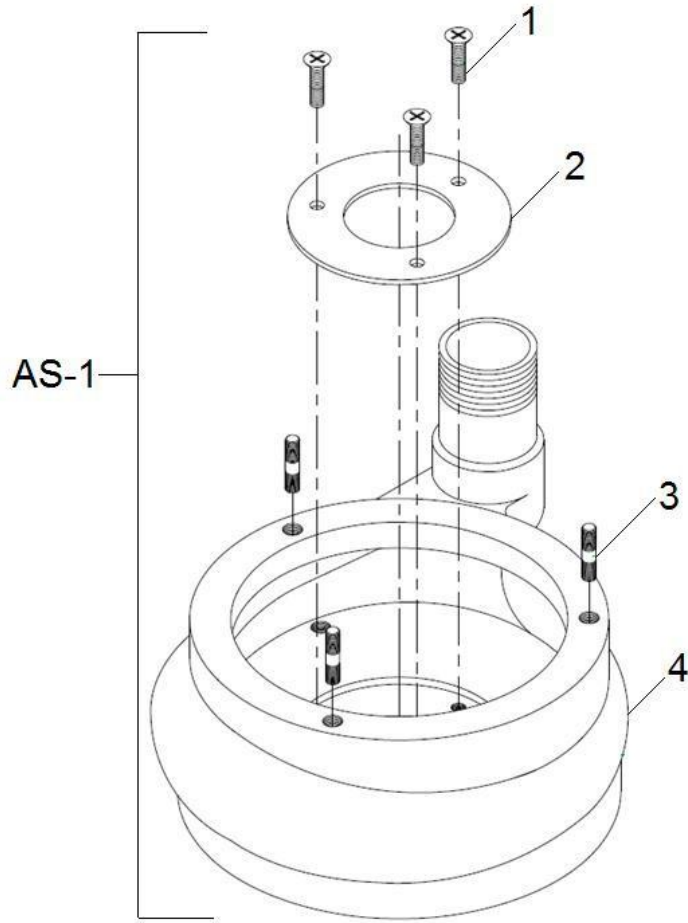

Pump Head – Body Assy (All Types)

Item No.	Product Code	Description	Qty	Remarks
1	See Remarks	FLX SCREW CSK M6X12 (633509)	3	Use AS-1 Not used on Cast Iron Pump Body
2	See Remarks	FLX WEAR PLATE (206309)	1	Use AS-1 Not used on Cast Iron Pump Body
3	NPS06303-UNIT	FLX STUD SS 0.375" BSW x 1.7" (590392)	3	
4	See Remarks	FLX BODY HOUSING ALUMINIUM (206310)	1	Use AS-1 (Suits FP212G)
	See Remarks	FLX BODY HOUSING CAST IRON (206320)	1	Use AS-1 (Suits P212A & P212)

Assembly / Service Kits - Pumps Head Body Assy (All Types)

Item No.	Product Code	Description	Qty	Remarks
AS-1	NPS06255-UNIT	FLX ASSY PUMP BODY ALUMINIUM (206380)	1	Suits all FP212G
	NPS08496-UNIT	FLX ASSY PUMP BODY CAST IRON (206381)	1	Suits all FP212A & FP212C

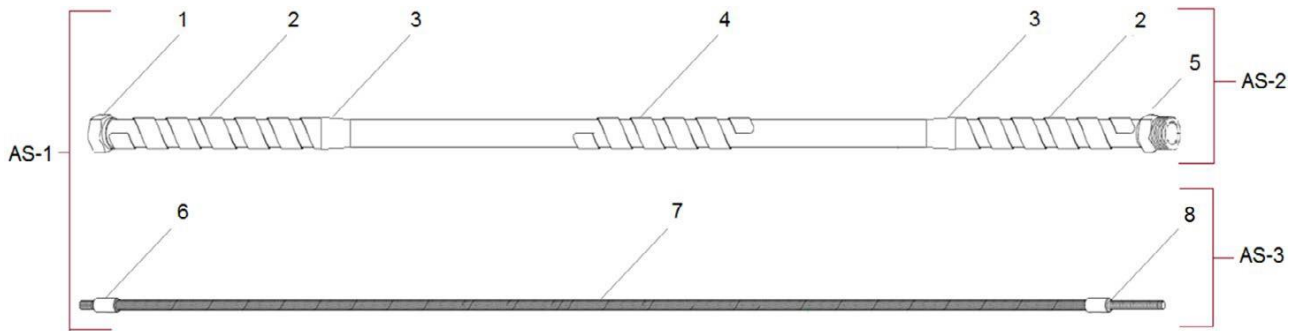

Flexshaft (All Types)

Item No.	Product Code	Description	Qty	Remarks
1	See Remarks	FLX FERRULE PUMP END 32MM (206103)	1	Use AS-1 or AS-2
	See Remarks	FLX FERRULE PUMP END 38MM (206108)	1	Use AS-1 or AS-2
2	See Remarks	FLX END SUPPORT SPRING 32MM (206102)	2	Use AS-1 or AS-2
	See Remarks	FLX END SUPPORT SPRING 38MM (206105)	2	Use AS-1 or AS-2
3	See Remarks	FLX COLLAR 32MM (340303)	2	Use AS-1 or AS-2
	See Remarks	FLX COLLAR 38MM (206112)	2	Use AS-1 or AS-2
4	See Remarks	FLX MIDDLE SUPPORT SPRING 32MM (206111)	1	Use AS-1 or AS-2
	See Remarks	FLX MIDDLE SUPPORT SPRING 38MM (206106)	1	Use AS-1 or AS-2
5	See Remarks	FLX FERRULE COUPLING END 32MM (310315)	1	Use AS-1 or AS-2
	See Remarks	FLX FERRULE COUPLING END 38MM (206104)	1	Use AS-1 or AS-2
6	See Remarks	FLX CORE END SCREW 13MM (206101)	1	Use AS-1 or AS-3
	See Remarks	FLX CORE END SCREW 15MM (206107)	1	Use AS-1 or AS-3
7	See Remarks	FLX INNER CORE 6M X 13MM (810124)	1	Use AS-1 or AS-3
	See Remarks	FLX INNER CORE 9M X 13MM (810155)	1	Use AS-1 or AS-3
	See Remarks	FLX INNER CORE 6M X 15MM (810180)	1	Use AS-1 or AS-3
	See Remarks	FLX INNER CORE 9M X 15MM (810183)	1	Use AS-1 or AS-3
8	See Remarks	FLX CORE END HEX 13MM (049210)	1	Use AS-1 or AS-3
	See Remarks	FLX CORE END HEX 15MM (053270)	1	Use AS-1 or AS-3

Assembly / Service Kits - Flexshaft (All Types)

Item No.	Product Code	Description	Qty	Remarks
AS-1	NPS01590-UNIT	FLX FLEXSHAFT ASSY 6M x 32MM (206946GZ)	1	Suits FP212G 6m long x 32mm casing diameter Inc Items: AS-2 & AS-3
	NPS01593-UNIT	FLX FLEXSHAFT ASSY 9M x 32MM (206949GZ)	1	Suits FP212G 9m long x 32mm casing diameter Inc Items: AS-2 & AS-3
	NPS01592-UNIT	FLX FLEXSHAFT ASSY 6M x 38MM (206946CGZ)	1	Suits FP212A & FP212C 6m long x 38mm casing diameter Inc Items: AS-2 & AS-3
	NPS01594-UNIT	FLX FLEXSHAFT ASSY 9M x 38MM (206949CGZ)	1	Suits FP212A & FP212C 9m long x 38mm casing diameter Inc Items: AS-2 & AS-3
AS-2	NPS01586-UNIT	FLX CASING ASSY 6M x 32MM (206946G)	1	Suits FP212G 6m long x 32mm casing diameter Inc Items: 1 - 5
	NPS01588-UNIT	FLX CASING ASSY 9m x 32MM (206949G)	1	Suits FP212G 9m long x 32mm casing diameter Inc Items: 1 - 5
	NPS01587-UNIT	FLX CASING ASSY 6M x 38MM (206946CG)	1	Suits FP212A & FP212C 6m long x 38mm casing diameter Inc Items: 1 - 5
	NPS01589-UNIT	FLX CASING ASSY 9M x 38MM (206949CG)	1	Suits FP212A & FP212C 9m long x 38mm casing diameter Inc Items: 1 - 5
AS-3	NPS01595-UNIT	FLX INNER CORE ASSY 6M x 13MM (206946Z)	1	Suits FP212G 6m long x 13mm core diameter Inc Items: 6 - 8
	NPS01598-UNIT	FLX INNER CORE ASSY 9M x 13MM (206949Z)	1	Suits FP212G 9m long x 13 mm core diameter Inc Items: 6 - 8
	NPS01596-UNIT	FLX INNER CORE ASSY 6M x 15MM (206946CZ)	1	Suits FP212A & FP212C 6m long x 15mm core diameter Inc Items: 6 - 8
	NPS01600-UNIT	FLX INNER CORE ASSY 9M x 15MM (206949CZ)	1	Suits FP212A & FP212C 9m long x 15mm core diameter Inc Items: 6 - 8

Coupling Assy (All Types)

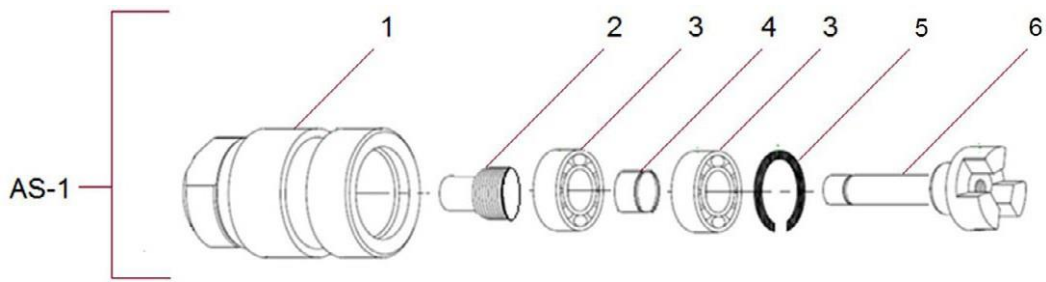

Coupling (All Types)

Item No.	Product Code	Description	Qty	Remarks
1	See Remarks	FLX BEARING HOUSING (360421)	1	Use AS-1
2	See Remarks	FLX HEX ADAPTOR (046310)	1	Use SK-1
3	See Remarks	FLX BEARING (550102)	2	Use SK-1
4	See Remarks	FLX SPACER (046330)	1	Use SK-1
5	See Remarks	FLX CIRCLIP (670105)	1	Use SK-1
6	See Remarks	FLX SPINDLE 3-TEETH (360422)	1	Use AS-1

Coupling (All Types) Assembly / Service Kits

Item No.	Product Code	Description	Qty	Remarks
AS-1	NPS01575-UNIT	FLX COUPLING ASSY (360420)	1	Inc Items: 1 - 6
SK-1	NPS01576-UNIT	FLX SERVICE KIT COUPLING ASSY (360420SK)	1	Inc Items: 2 - 5



Flextool

1956 Dandenong Road, Clayton VIC 3168, Australia

Phone (AUS): 1300 353 986

flextool.com.au

ABN 80 069 961 968

This manual summarises our best knowledge of the product based on the information available at the time of publication. You should read this manual carefully and consider the information in the context of how the product will be used. Our responsibility for products sold is subject to our standard terms and conditions of sale.

DISCLAIMER:

Any advice, recommendation, information, assistance or service provided by us in this manual is given in good faith and is believed by us to be appropriate and reliable. However, any advice, recommendation, information, assistance or service provided by us is provided without liability or responsibility PROVIDED THAT the foregoing shall not exclude, limit, restrict or modify the right entitlements and remedies conferred upon any person or the liabilities imposed upon us by any condition or warranty implied by Commonwealth, State or Territory Act or ordinance void or prohibiting such exclusion limitation or modification. The product can be expected to perform as indicated in this manual so long as operation and operational procedures of the individual products are followed as recommended in this manual.

Design and technical specifications may be subject to changes.

© This publication is copyright. All rights are reserved. Flextool is a registered trade mark of Parchem Construction Supplies Pty Ltd.