



OPERATING INSTRUCTIONS

MIKASA FORWARD PLATE COMPACTOR MVC-e60



Version 1.0 (April 2024)

FOR MORE INFORMATION
CONTACT US ON 1300 353 986 OR VISIT flextool.com.au

EXCLUSIVE TO



Mikasa

PLATE COMPACTOR

MVC-e60VAS

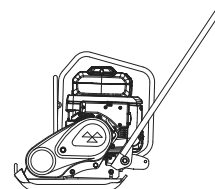

INSTRUCTION MANUAL

en



<http://www.mikasas.com>

402-12202



Table of contents

1. INTRODUCTION.....	1
2. FUNCTIONAL OVERVIEW.....	1
3. WARNING SIGNS	2
4. CAUTIONS FOR SAFETY.....	2
4.1 General Cautions	2
4.2 Cautions for Attaching and Removing the Battery Pack	3
4.3 Precautions before Starting Work	3
4.4 Precautions during Work	3
4.5 Precautions while Lifting	4
4.6 Precautions for Transportation and Storage	4
4.7 Precautions for Maintenance	4
4.8 Precautions for battery pack and battery charger	4
4.9 Decals Position	5
4.10 Descriptions of the Warning Decals	6
5. SPECIFICATIONS.....	8
5.1 Plate Compactor	8
5.2 DC power unit	8
5.3 Battery	8
5.4 Charger	9
5.5 Plug of Charger	9
6. APPEARANCE	10
6.1 Dimensions	10
6.2 Components	11
7. INSPECTION BEFORE OPERATION	12
7.1 Inspection	12
7.2 Battery Pack and Battery Charger	13
7.3 Attaching and Removing the Battery Pack	13
7.4 How to use Revolving type cart	14
8. OPERATION	16
9. STOPPING THE DC POWER UNIT.....	17
10. TRANSPORTATION.....	17
11. CLEANING.....	17
12. STORAGE.....	17
13. INSPECTION AND MAINTENANCE.....	18
13.1 Maintenance Schedule	18
13.2 Inspection	18
14. TROUBLESHOOTING.....	20
14.1 DC Power Unit, Battery Pack and Battery Charger	20
14.2 Plate compactor	20
15. WIRING DIAGRAM.....	21

1. INTRODUCTION

- This instruction manual describes the proper methods for using the plate compactor, as well as simple checks and maintenance. Be sure to read this instruction manual before using the plate compactor, in order to get full use of the excellent performance of this machine, to improve your operation and to perform work effectively.
- After reading this manual, store it in a handy location for easy reference.
- For details about the DC POWER UNIT, BATTERY PACK and BATTERY CHARGER for this machine, see the separate owner's manual for them.
- For inquiries about repair parts, parts lists, service manuals and repair of the machine, please contact the shop where you purchased it, or the Mikasa Website. In addition, parts lists are available on the MIKASA website at: <http://www.mikasas.com/english/>

The illustrations in this manual might slightly differ in part from the machine you actually purchased due to design changes.

2. FUNCTIONAL OVERVIEW

Application

This plate compactor is the machine that compact the ground and it intends to make the smooth ground surface. This machine is suitable for making the smooth ground surface, such as leveling the soil and sand, finishing the asphalt. Its applications include compacting for road, embankments and reservoirs as well as backfilling for gas pipelines, water pipelines and cable installation work.

Warning about Incorrect Applications and Techniques

Plate compactor is hard to move forward on a soil with much water (especially clay soil).

Plate compactor is difficult to compact a ground include big stones due to insufficient compacting force. Therefore, it is not suitable for such the above application.

Plate compactor is mainly used to compact the smooth ground surface, it is not effective for jobs that requires heavy compaction.

In case of requiring heavy compaction, it is recommended to use Plate compactor, Reversible Compactor or Vibration Roller, which has strong compaction force.

Structure

This machine is a walk-behind, one-way plate compactor.

The upper section of the plate compactor consists of the DC power unit, handle, guard hook, water tank and belt cover, which are assembled on engine base.

The lower section of the plate compactor consists of the vibrating plate and vibrator unit that has an eccentric rotor in vibrating case.

The upper section and lower section are assembled by shock absorbers, and DC power unit and vibrator are connected by V-belt.

Power Transmission

This machine is equipped with the DC power unit as power unit.





Transmission of the power takes place by increasing the DC power unit speed to engage the centrifugal clutch.

The DC power unit speed is transmitted to the vibrator on vibrating plate by V-belt, and it generates vibration by rotating an eccentric rotor in the vibrator.

Vibration of vibrating plate creates to travel the machine to forward and the vibration and weight of machine creates compaction force to ground.

3. WARNING SIGNS

The triangle shaped  marks used in this manual and on the decals stuck on the main body indicate common hazards. Be sure to read and observe the cautions described.

 Warning labels indicating hazards to humans and to equipment.	
 DANGER	Denotes an extreme hazard. It calls attention to a procedure, practice, condition or the like, which, if not correctly performed or adhered to, is likely to result in serious injury or death.
 WARNING	Denotes a hazard. It calls attention to a procedure, practice, condition or the like, which, if not correctly performed or adhered to, could result in serious injury or death.
 CAUTION	Denotes a hazard. It calls attention to a procedure, practice, condition or the like, which, if not correctly performed or adhered to, could result in injury to people and may damage or destroy the product.
CAUTION (without at )	Failure to follow the instructions may result in damage to property.

4. CAUTIONS FOR SAFETY

4.1 General Cautions

DANGER

- Do not use the machine in the rain and machine wet with water.
- Do not use the machine near flames.
- Do not touch the machine with wet hands. It is dangerous about electric shock and electric leakage.

WARNING

- Do not work with this machine, when
 - you are tired or sick and not feeling well.
 - you have taken medicine or drug.
 - you have had a drink.

CAUTION

- Please read the operation manual well and work safely by using the machine properly.
- For handling of the DC power unit, battery pack and battery charger. Please read to the attached operation manuals for them.
- Please understand of the structure of this machine well.
- Make sure to do the inspection and check the machine conditions before starting operation.
- Please use protective equipment such as helmet, protective shoes, protective gloves, etc., and wear appropriate work clothes for making your work safe.
- Always wear noise protection equipment such as ear muffs or ear plugs and protective eyeglasses.
- The decals shown operation method, warning and etc. stuck on the machine are very important for your safety. Clean the machine so that the decals can be read easily. If it is difficult to read the decals, please replace with new ones.
- It is dangerous if children touch the machine. Please be careful about storage location and storage method for the machine.
- Stop the DC power unit before maintenance work.
- We are not responsible for any accidents occurred due to the fixing without using genuine parts (foot and etc.) and equipment modifications.



4.2 Cautions for Attaching and Removing the Battery Pack

DANGER

- Be sure to press STOP on the START/STOP switch.
- Be sure to work in a clear and flat location without any combustibles nearby.
- After attaching the battery pack, make sure the battery hook and fastener are securely attached.

CAUTION

- Close the battery fastener lever while removing the battery pack.

4.3 Precautions before Starting Work

CAUTION

- Always perform a pre-operation inspection before each operation and correct any problems.
- Always check the equipment for loosened threads or bolts before starting.
- Before attaching the Battery Pack, make sure that:
 - Exterior cover is not damaged.
 - Switches are not damaged.
 - Rubber support is not damaged.
 - Battery hook is not loose or damaged.
 - Battery fastener is not damaged.
 - Battery connector is not damaged.
 - Motor wire harness is not damaged. (For GXE2.0S only)
 - There are no debris or excessive dirt on the DC Power Unit or the Battery Pack.
- During the test run
 - Check that all switches work (start and stop) properly
 - Check that all indicators light when the DC Power Unit is turned on

4.4 Precautions during Work

CAUTION

- If you use the machine for a long time, be careful to watch for signs of vibration syndrome. Since this machine vibrates, work for a long time may have a negative effect on your body. Take sufficient breaks while working.
- Before starting to operate the machine, check the safety for people around and obstacles nearby.
- Always be careful around ground condition at job site. Operate the plate compactor in stable position and balance.
- Do not touch the DC power unit during work or soon after work, because it is very hot.
- If you find trouble or damage of the machine during work, stop work immediately.
- Before leaving or moving the machine, be sure to stop the DC power unit.



4.5 Precautions while Lifting

CAUTION

- Before lifting the machine, make sure that there is no damage to parts on the machine (especially the shock absorber and the hook), loosening or missing of the bolt, and the machine must be in a safe condition.
- Stop the DC power unit before lifting the machine.
- Use adequate lifting cable (wire or rope) of sufficient strength for support to the machine.
- Do not lift it higher than necessary for safety.
- Do not use a damaged lifting cable.
- Use one point lifting hook for lifting the machine and lift straight upwards. Do not use any other points (such as the handle) for lifting.
- Never lift or suspend the machine rapidly with hydraulic excavator.
- Never allow any person or animal to stand underneath the machine while lifting.
- Be careful not to an accident when using any lifting equipment. Before using the lifting equipment, make sure that there is no trouble or damage.

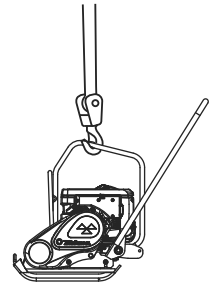

4.6 Precautions for Transportation and Storage

DANGER

- Stop the DC power unit before transporting or storing the machine.
- After the DC power unit and main body has cooled down enough, transport or store the machine.
- Remove the battery pack before transporting or storing the machine.
- Maintain upright position of this plate compactor on a level ground during transporting or storing.
- Tie down the plate compactor with cable (wire or rope) so that it cannot move or fall over.
- When lifting the plate compactor with the handle, be careful not to pinch your fingers between the handle and main body.
- When transporting the plate compactor, use MC-1B of Mikasa Carry or similar product.
- Avoid storage areas with high temperature and high humidity, or environments with severe temperature changes. Keep away from direct sunlight and rain.

4.7 Precautions for Maintenance

WARNING

- Ensure safety for maintenance. It needs appropriate maintenance for keeping the machine performance. Keep the machine in good condition with attention to the machine's condition always.

CAUTION

- Be sure to stop the DC power unit before maintenance of the machine.
- Do not touch the parts that became hot until they have cooled down enough to prevent burn.
- Do not touch the lubrication oil and engine oil until they have cooled down enough to prevent burn.
- When maintenance of the machine with disassembling, be sure to refer the service manual and always work safely.
- After maintenance of the machine, check that the parts are assembled properly and machine conditions are safe.



4.8 Precautions for Battery Pack and Battery Charger

The battery pack and battery charger are provided with each owner's manual. Follow them when you operate the battery pack and battery charger.

4.9 Decals Position

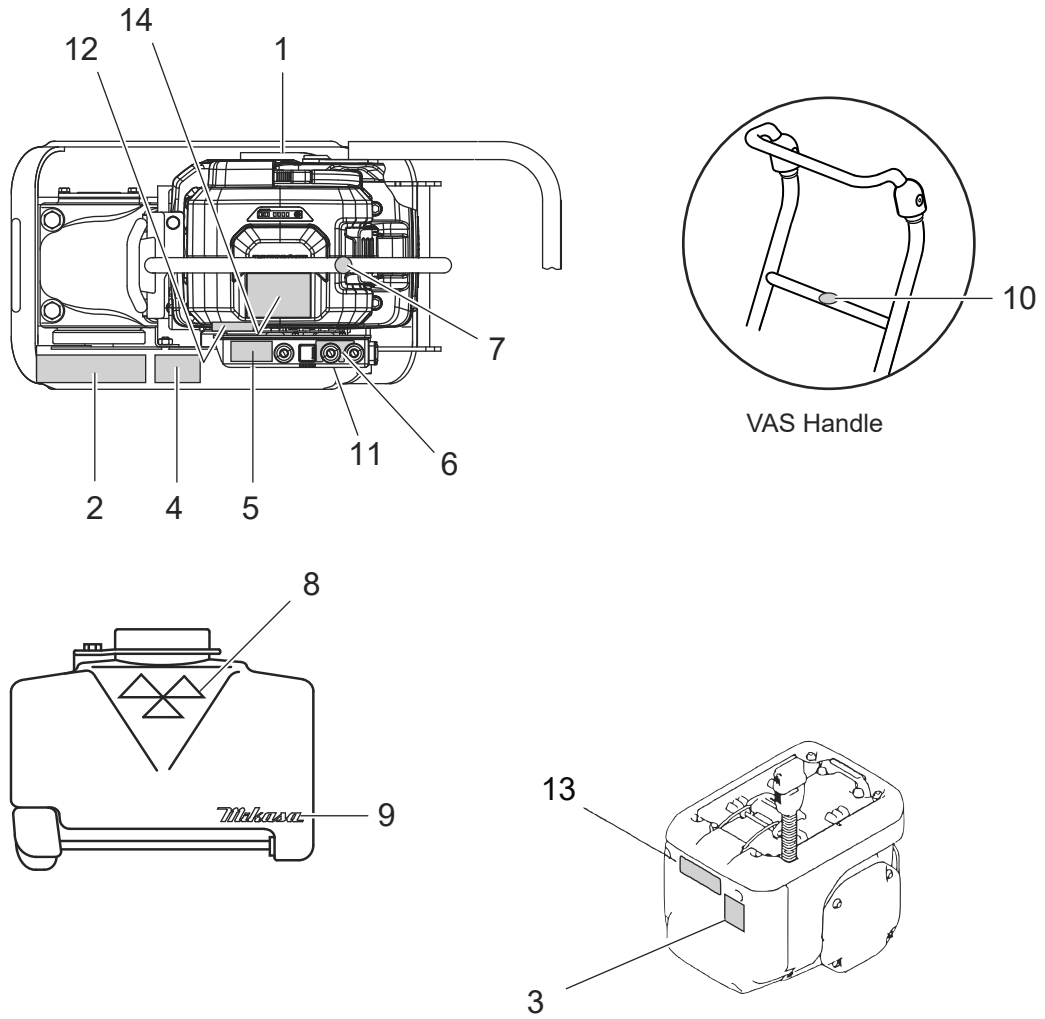

※ VAS = Vibration Absorbing System

REF No.	PART No.	PART NAME	Q' TY	REMARK
1	9202-24330	PLATE,SERIAL NO./e60/5LANG	1	NPA-2433
2	9202-24400	DECAL /MVC-e60 /GR	1	NPA-2440, GREEN
2	9202-24410	DECAL /MVC-e60 /OR	1	NPA-2441, ORANGE
3	9202-24280	DECAL,EC NOISE REQ.LWA100	1	NPA-2428
4	9202-24350	DECAL,CAUTION /COMBI./e60	1	NPA-2435
5	9202-24360	DECAL,START-STOP/eGX	1	NPA-2436
6	9202-24390	DECAL,LED/e60	1	NPA-2439
7	9202-14740	DECAL,LIFTING POSITION	1	NPA-1474
8	9201-13140	DECAL,MIKASA(BLACK,40X80)	1	NP-1314
9	9201-14000	DECAL,MIKASA(125MM)BLACK	1	NP-1400
10	9202-14730	DECAL,DO NOT LIFTING	1	NPA-1473
11	9202-24690	DECAL,EARTH SMART	1	NPA-2469
12	9202-24760	DECAL,CAUTION RAINY&WASH	1	NPA-2476
13	87516-8A0-600	MARK,OPER CAUTION(EU)	1	
14	1D143-8B0-E01	LABEL,CAUTION(E)EXP/eGX	1	

4.10 Descriptions of the Warning Decals

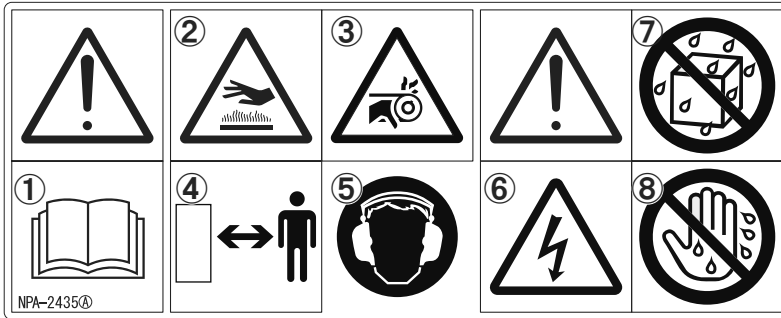

9202-24350 DECAL,CAUTION /COMBI./e60

- ① **Read the manual carefully.**
Always read the operation manual and have good understanding of operation before working.
- ② **Burn hazards.**
Never touch the hot parts. Allow these parts to cool before servicing the machine.
- ③ **Rotating parts hazards.**
Keep fingers, hands, hair and clothing away from all moving parts to prevent injury.
- ④ **Mechanical hazards.**
During operation, be careful not to approach danger source.
- ⑤ **Hearing hazards.**
Always use ear plugs during operating the machine.
- ⑥ **Electric shock hazards**
Be careful about electric shock. Stop the DC power unit before maintenance.
- ⑦ Do not use the machine in the rain and wet machine.
- ⑧ Do not use the machine with wet hands



No lifting position.

Do not use any other points (such as the handle) except one point lifting hook for lifting the machine.



Lifting position.

Use one point lifting hook for lifting the machine.

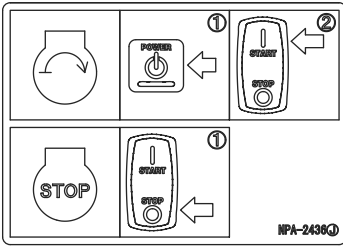

START

- ① Press the POWER button.
- ② Press the START/STOP switch to the START position.

STOP

- ① Press the START/STOP switch to the STOP position.

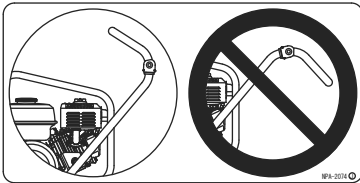

Caution of mounting direction of VAS handle

Assemble VAS handle with grip directed upward.



- ① Do not use high pressure washer. Keep dry.
- ② Do not use the machine in the rain and wet machine.



Caution decal put on the battery

- ① Read the manual carefully.
Always read the owner's manual and have good understanding of operation before working.
- ② Fire hazards.
Be careful of any flames from the battery.

5. SPECIFICATIONS

5.1 Plate Compactor

Model			MVC-e60VAS
Dimensions	Length	mm (inch)	915 (36.0)
	Width		350 (13.8)
	Height (with handle)		995 (39.2)
Plate Size	Length	mm (inch)	570 (22.4)
	Width		350 (13.8)
Lubrication Oil			API Service Categories SE or higher SAE 10W-30
Vibrator Oil Capacity		liter (qt.)	0.14 (0.148)
Vibrating Frequency		Hz (V.P.M.)	93 (5600)
Centrifugal Force			10.1kN (1030kgf, 2271lbf.)
Operating Weight		kg (lbs.)	80 (176)
Water Tank Capacity		liter (qt.)	11 (11.6)
Retard Operating time			About 30min/1.6kW

5.2 DC power unit

Model		Honda GXE2.0H
Type		Three-phase brushless DC motor
Weight without Battery	kg (lbs.)	18.5 (40.8)
Cooling System		Forced Air
Max. Output		1.8kW (2.1HP, 2.2PS)/3600rpm
Voltage	V	72

5.3 Battery



Model			Honda DP72104Z
Type			Rechargeable Lithium Ion Battery
Dimensions	Length	mm (inch)	233 (9.2)
	Width		268 (10.6)
	Height		150 (5.9)
Weight	kg (lbs.)		6.4 (14.1)
Voltage	V		72
Power Capacity	Wh		720
Charging temperature range	°C (°F)		5 - 30 (41 - 86) Battery Packs cannot be charged at temperatures of 5C (41F) or colder
Operating temperature range	°C (°F)		5 - 40 (41 - 104)
Storage temperature range	°C (°F)		-5 - 30 (23 - 86)



- ※ Machine weight when it is equipped with a revolving type moving cart will increase to 2kg each weight.
- ※ VAS = Vibration Absorbing System
- ※ Specifications are subject to change without notice.

5.4 Charger

Model			Honda CV7285Z
Dimensions	Length	mm (inch)	266 (10.5)
	Width		352 (13.9)
	Height		247 (9.7)
Weight		kg (lbs.)	11.0 (24.2)
Cable Length		mm (inch)	2000 (78.7)
Input Voltage		V	AC100 - 240
Input Frequency		Hz	50/60
Output Voltage		V	DC82.8
Charging Temperature Range		°C (°F)	5 - 30 (41 - 86)
Charging Time	80%	hour	1
	100%		1.5

5.5 Plug of Charger

Destination		North America	Europe	Switzerland
Input Voltage	V	AC120	AC230	AC230
Plug Type				

Destination		UK	Japan
Input Voltage	V	AC240	AC100
Plug Type			

※ Specifications are subject to change without notice.

6. APPEARANCE

6.1 Dimensions (mm)

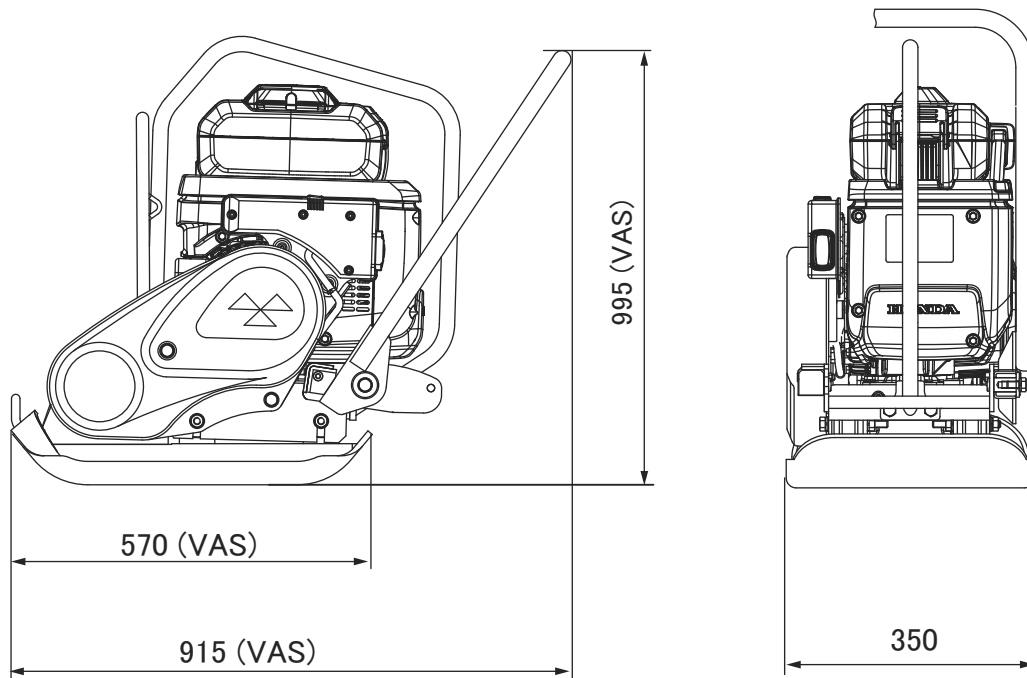

- ※ Specifications are subject to change without notice.
- ※ VAS = Vibration Absorbing System

6.2 Components

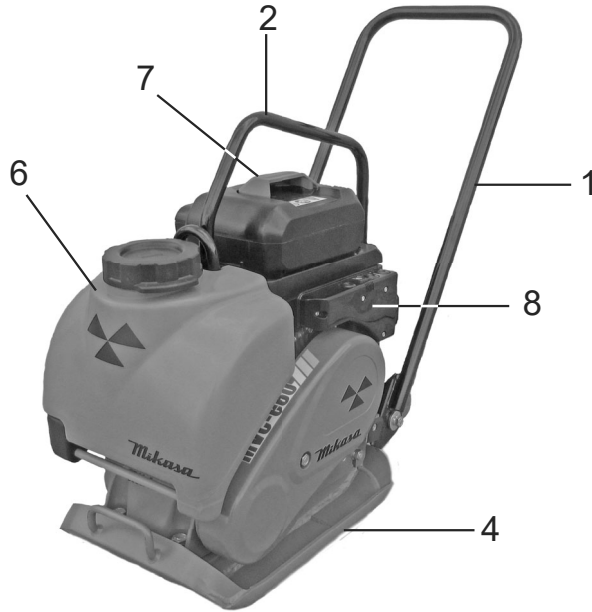

1. Handle
2. Guard Hook
3. Vibrator
4. Vibrating Plate
5. Vibration Absorbing System Handle (VAS)
6. Water Tan
7. Battery Pack
8. Switch Box
9. START/STOP Switch
10. Power Button
11. Power Indicator (Green)
12. Alert Indicator (Orange)
13. Error Indicator (Red)
14. Cart
15. Power Cable
16. Battery Connector Cap
17. Battery Tray
18. Battery Hook
19. Battery Fastener
20. Battery Fastener Lever
21. Battery Support

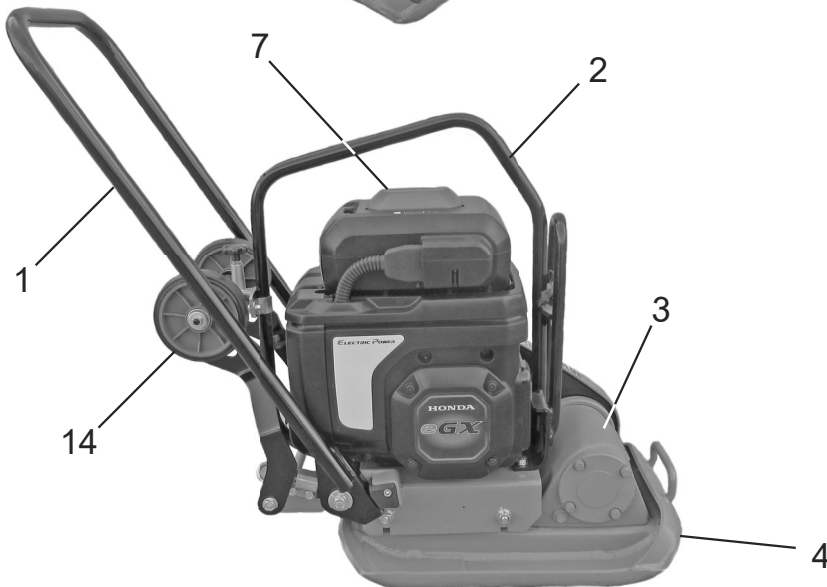

Vibration Absorbing System Handle

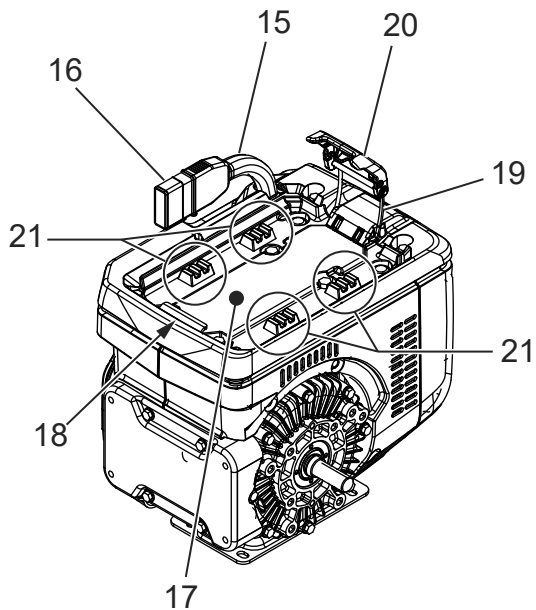
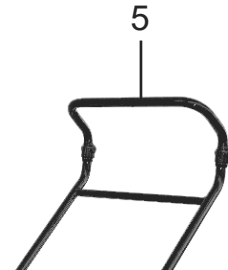

Switch Box

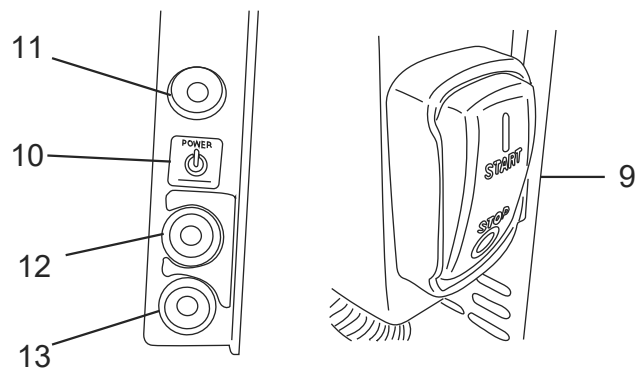

7. INSPECTION BEFORE OPERATION

⚠ WARNING

- Check the machine while the DC power unit is stopped. You may be caught in a rotating part and be seriously injured.
- Check the machine after it ties down on level ground to avoid falls.
- Check the machine after it has cooled down to avoid burns.



⚠ CAUTION

- It is extremely important that this section be read carefully before attempting to operate the plate compactor.
- Do not use your plate compactor until this section is thoroughly understood.
- The DC power unit, battery pack and battery charger are provided with each owner's manual. Follow them when you operate the DC power unit, battery pack and battery charger.

Inspection points	Inspection items
Appearance	Flaws, deformity, dirt
Vibrating plate	Wears, deformity, breaks
Bolts, nuts	Loose or missing
Handle	Flaws, deformity, cracks, breaks
Shock absorber	Flaws, deformity, cracks, breaks
Vibrator oil	Leaks, oil level, dirt
Engine bolt	Wears, deformity, breaks

7.1 Inspection

1. Clean each parts of the machine.
Thoroughly remove dirt and oil from the machine.
2. Make sure that all bolts and nuts are not loosened. If they are loosened, retighten them to prevent an accident and trouble.
3. Make sure that the guard hook, belt cover and shock absorbers are not damaged. If they are damaged, replace new ones.
4. Replace any missing or damaged safety and operation decals.
5. Check the V-belt tension. The V-belt tension is proper if the V-belt bents about 10 - 15mm when depressed with finger at midway between the clutch and vibrator pulley. If V-belt tension is loosened, power is not transmitted well, so reduces compacting force and shortens the life of V-belt.
6. Place the plate compactor on the level surface. Check the vibrator oil level by removing the oil plug. (Fig.1)
The oil level should be up to the level of oil plug hole.
 - **Vibrator oil:**
API Service Categories SE or higher SAE 10W-30
 - **Oil capacity:** 140cc

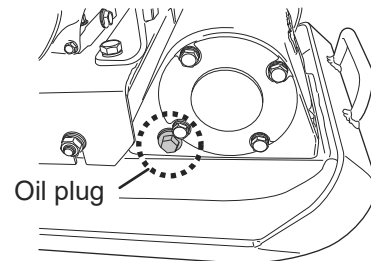

Fig.1

- **Tightening torque of oil plug:**
39.2 N·m (400kgf·cm)

7. If your unit is equipped with the water tank and your application requires sprinkling work, fill water into the water tank.

Note: Fill water only. If you should fill liquids other than water, the resin, tank cap and other parts of water tank may cause deterioration, expansion, leakage or damage.

8. The water tank can be removed by pulling it upward. When mounting the water tank again, insert the hook into the groove of the water tank securely. The amount of sprinkling water can be adjusted by the cock.

7.2 Battery Pack and Battery Charger

The battery pack and battery charger are provided with each owner's manual. Follow them when you operate the following operations of battery pack and battery charger.

- Charging and Charge Level
- Cleaning
- Storage
- Disposal

7.3 Attaching and Removing the Battery Pack

Follow the owner's manual for the DC power unit when attaching and removing the battery pack.

● Attaching the battery pack

Make sure to use a genuine Battery Pack.

1. Make sure there are no debris or dirt on the battery tray.(Fig.3)

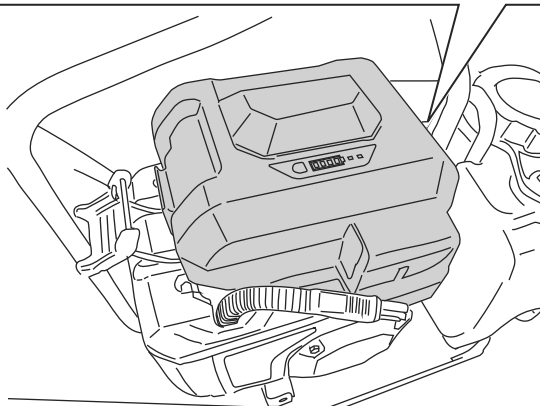
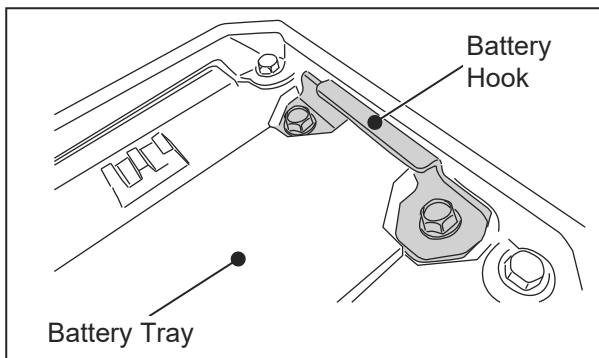

Fig.3

2. Tilt the Battery Pack and insert its claw into the battery hook.(Fig.3)
3. Push down the Battery Pack and hook the battery fastener to it.(Fig.4)
4. Push the battery fastener lever up and lock the Battery Pack.(Fig.4)
Be careful not to catch your fingers.

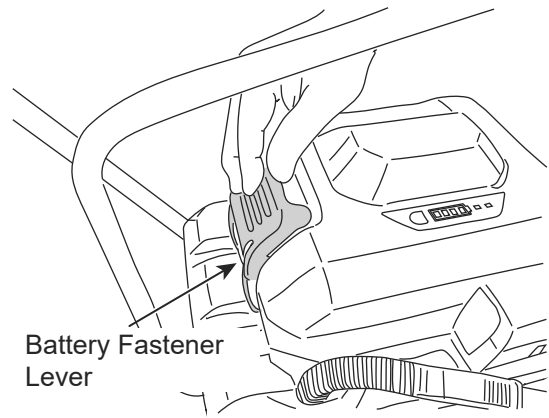

Fig.4

5. Remove the battery connector cap from the power cable.(Fig.5)
Connect the power cable to the battery connector of the Battery Pack.(Fig.6)

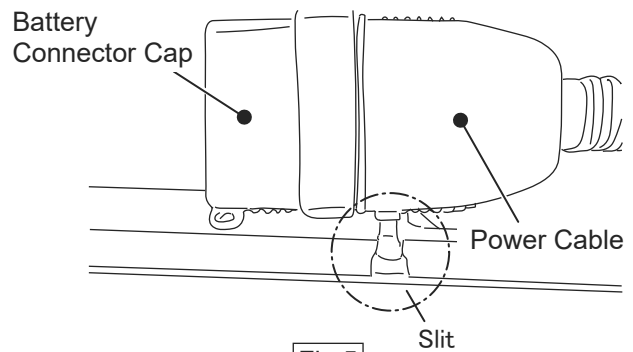

Fig.5

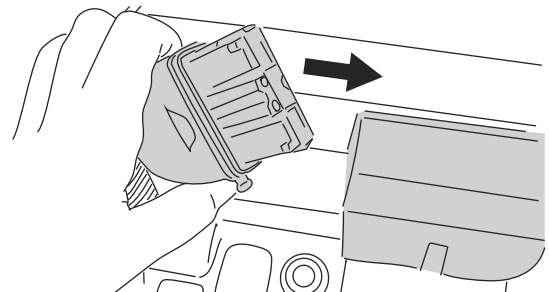

Fig.6

After attaching the Battery Pack, make sure the battery hook and fastener are securely attached.

● Removing the battery pack

1. Remove the power cable from the Battery Pack.(Fig.6)
2. Pull the battery fastener down to unlock, tilt the Battery Pack up and pull the Battery Pack claw out from the battery hook, and remove the Battery Pack.(Fig.3,4)
3. Attach the battery connector cap to the power cable.(Fig.5)

7.4 How to use Revolving type cart

For attaching and removing the cart, place the plate compactor on secure level ground with the DC power unit stopped.

● Storing position to Operating position

1. Pull up the knob of cart stopper, then revolve the cart until contacting the ground. (fig. 7)

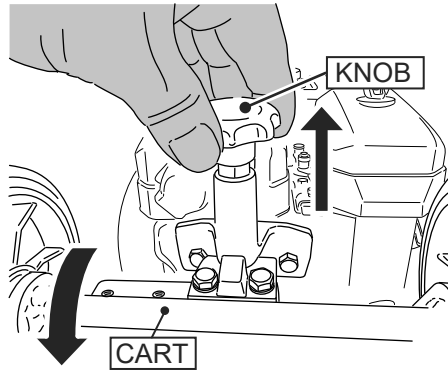

Fig.7

2. Move the handle to operating position, then fix it with the handle stopper.
 - a. Turn the eye nut of handle stopper to the right 90 degrees (fig. 8), then push it (fig. 9).

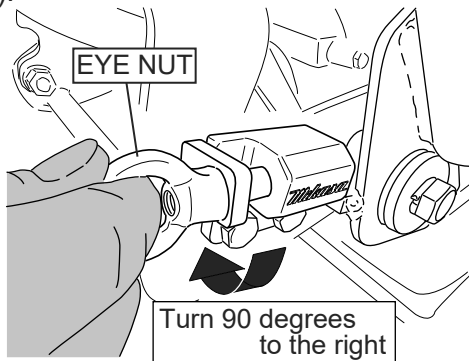

Fig.8

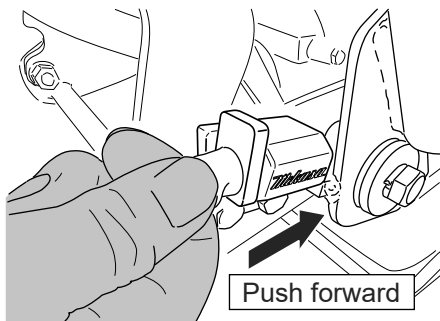

Fig.9

- b. Fix the handle by inserting the stopper pin to the stopper of handle (fig.10).

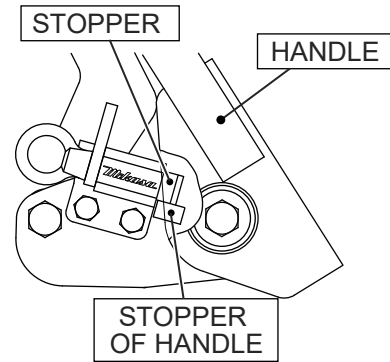

Fig.10

3. Tilt the handle to the front until the rear end of vibrating plate leaves the ground. Then, revolve the cart to the underside of vibrating plate until the frame of cart contacts the vibrating plate (fig. 11).

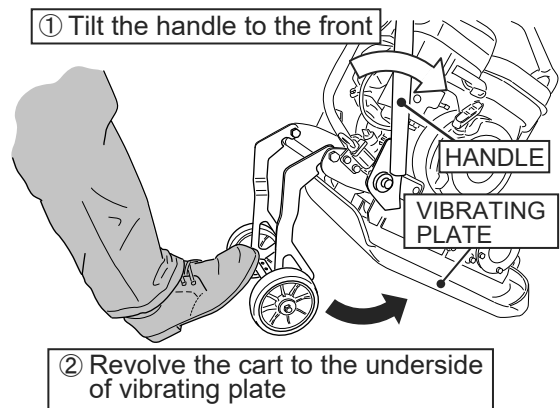

Fig.11

4. Pull back the handle to the rear, and lift up the vibrating plate by cart. Then, move the plate compactor keeping horizontal position (fig. 12).

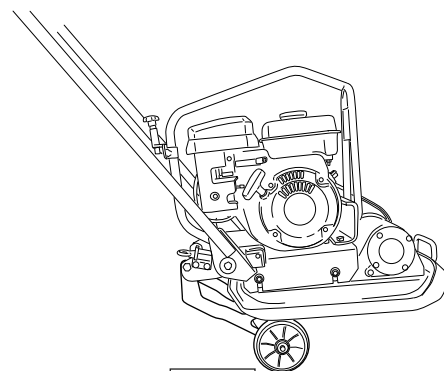

Fig.12

● **Operating position to Storing position**

1. Put the plate compactor so that the front end of vibrating plate contacts the ground. Then, tilt the handle to the front until the cart leaves the ground (fig. 13).

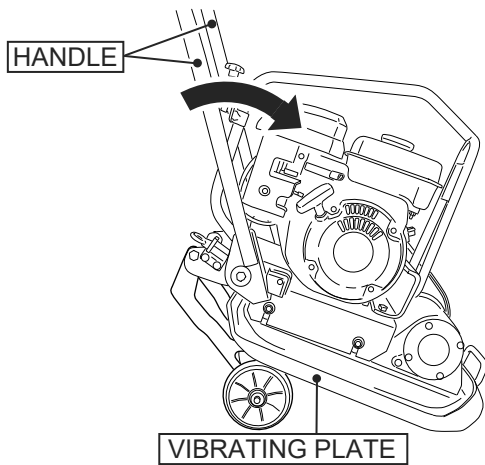

Fig.13

2. Revolve the cart to the rear, then put the plate compactor the ground (fig.14).

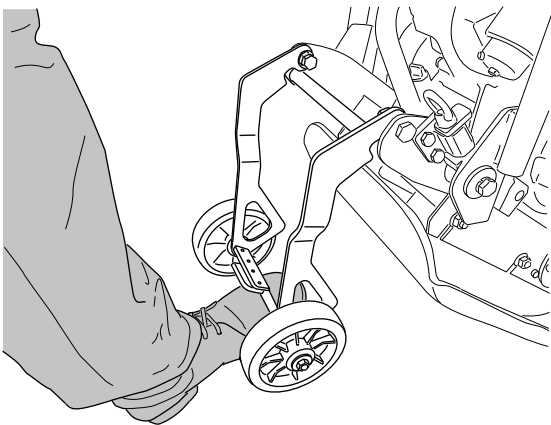

Fig.14

3. Revolve the cart until the storing position (fig. 15).

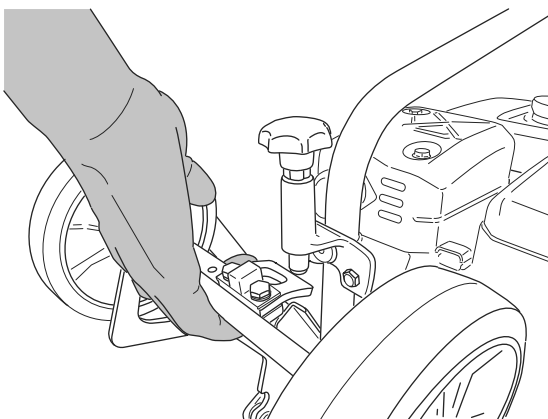

Fig.15

4. When contacting the stopper rubber of cart and cart stopper, the cart is fixed at storing position by self-locking system (fig. 16).

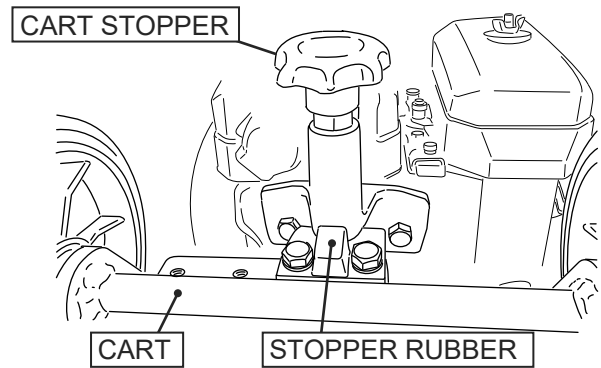

Fig.16

5. Pull the eye nut of handle stopper, then turn it to the left 90 degrees (fig. 17).

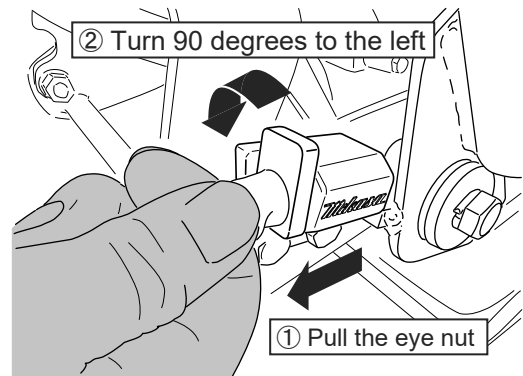

Fig.17

6. The storing is complete.

8. OPERATION

1. Press STOP on the START/STOP switch.
2. Press the POWER button.
All the indicators should illuminate for a few seconds, and then only the POWER indicator remains illuminated.
3. Hold the handle firmly. Then, Press the START/STOP switch to the START position to start moving forward by starting the DC Power Unit.

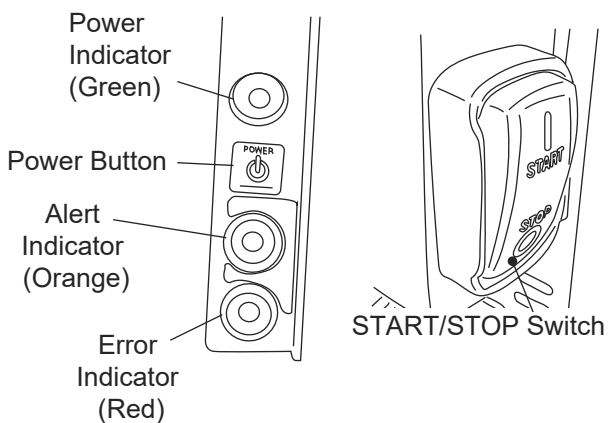

Fig.18

CAUTION

- If the POWER button is pressed when the START/STOP switch is in the START position, the POWER indicator remains off and the ALERT indicator flashes. In this case, the DC Power Unit cannot start. Press the START/STOP switch to the STOP position and then press the POWER button.
- It may take some time for the indicators to light after the POWER button is pressed. If the indicators do not light, press the POWER button again.
- If the DC Power Unit is not operated for about one minute after the POWER button is pressed, the POWER indicator turns off. Press the POWER button again to start the DC Power Unit.

CAUTION

- DO NOT use this machine on ground that is harder than the machine can handle, or for driving pilings or tamping rock beds. Furthermore, use of the machine on sloping ground, such as the side of an embankment, may make the machine unstable and can cause an accident. It can also result in premature machine wear due to uneven loads on the machine.
- Use the machine with confidence for tamping earth and sand, soil, gravel, and asphalt.
- DO NOT use the machine for other types of jobs.
- In cold weather, the rammer can be warmed up by Pressing the START/STOP switch START and STOP several times until the rammer operates smoothly.

5. If your unit is equipped with the water tank and your application requires sprinkling work, open the cock of water tank.(fig. 19)

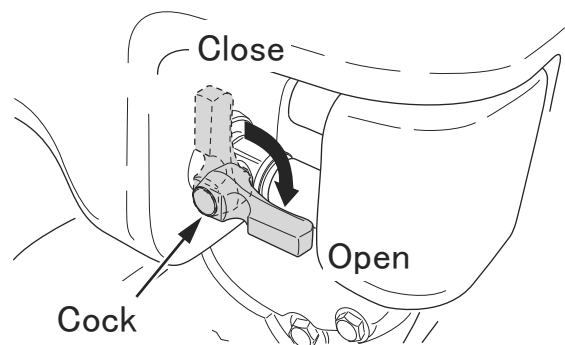

Fig.19

9. STOPPING THE DC POWER UNIT

1. Press the START/STOP switch to the STOP position.
The DC Power Unit stops and the POWER indicator turns off.

CAUTION

You can also stop the DC Power unit by pressing the POWER button, but it may take some time to stop.

1. When stopping sprinkling work, close the cock of water tank.(fig. 20)

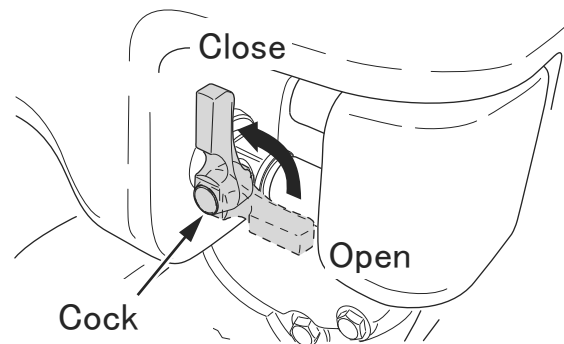

Fig.20

10. TRANSPORTATION

1. Stop the DC Power unit before transporting the machine.
2. Do not move the machine until the DC Power Unit and main body have cooled down enough.
3. Remove the Battery Pack.
4. Maintain upright position of the plate compactor on a level ground during transporting.
5. Tie down the plate compactor with cable (wire or rope) so that it cannot move or fall over during transporting.

11. CLEANING

Do not use a hose or pressure washer to spray water on the DC Power Unit and Battery Pack while cleaning them. Water entering the components may cause a malfunction.

12. STORAGE

1. Store the machine the same procedure as 10. TRANSPORTATION.
2. Avoid storage areas with high temperature and high humidity, or environments with severe temperature changes. Keep away from direct sunlight and rain.
3. Put a cover on the machine to avoid depositing dirt.

13. INSPECTION AND MAINTENANCE

Proper maintenance is essential for safe, economical, reliable, and environmentally friendly operation.

⚠ WARNING

- Check the machine while the DC power unit is stopped. You may be caught in a rotating part and be seriously injured.
- Check the machine after it ties down on level ground to avoid falls.
- Check the machine after it has cooled down to avoid burns.



Regarding the inspection and maintenance of the DC Power unit, Battery Pack and Battery Charger, always follow each owner's manuals.

13.1 Maintenance Schedule

Check frequency	Check parts	Check items	Oils
Daily (before starting)	Appearance	Flaw, deformation	
	Shock absorber, and other rubbers	Crack, damage, wear	
	Vibrator oil	Leakage	Engine oil
	Guard frame	Breakage, flaw, loosened or missing bolts and nuts	
	Battery fastener	Crack, damage, wear	
	Bolts and nuts	Looseness, missing	
	Switch box	Looseness	
Every 200 hours	V-belt	Flaw, deformation	
	Clutch	Dirt, flaw, wear	
	Vibrator oil	Replace	Engine oil
	Engine bolt	Wear, deformation, degradation	

⚠ CAUTION

- The above table shows the check frequency for standard condition.
- The check frequency may vary depending on the condition in which the machine is used.

13.2 Inspection

- Daily inspection
 - Clean each parts of the machine. Thoroughly remove dirt and oil from the machine.
 - Make sure that all bolts and nuts are not loosened. If they are loosened, retighten them to avoid an accident and trouble.

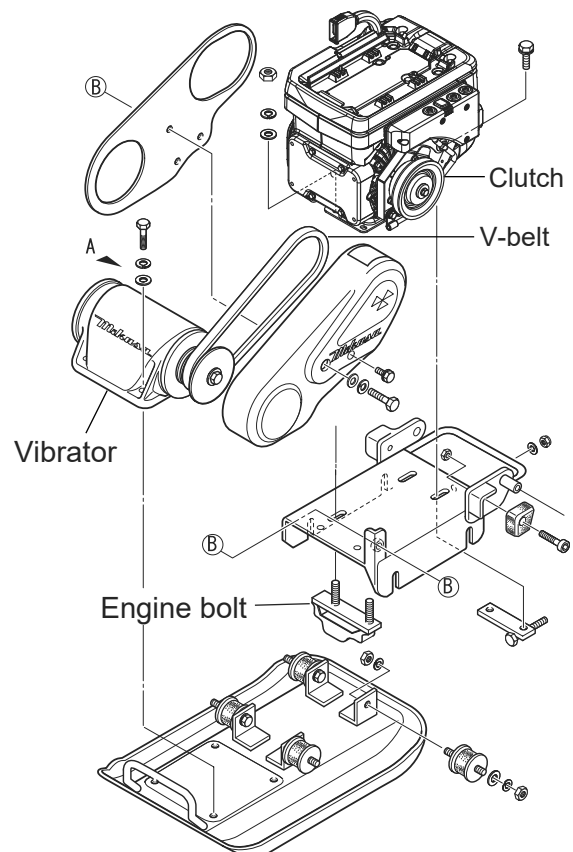

Fig.21

2. 200 hours service

1. Changing the vibrator oil (fig.22)

- When changing the vibrator oil, remove the drain plug.
- Tilt the plate compactor to drain the oil. Note that the oil will drain more easily while it is hot.
- Replace with new oil.
- Check the oil level as 6. of 7.1 INSPECTION (P12).

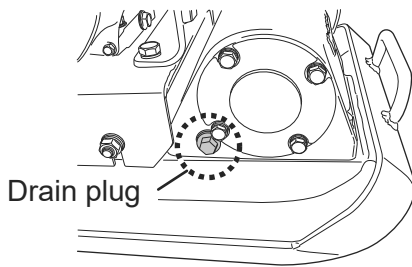

Fig.22

2. Checking the V-belt (fig.23)

- Remove the belt cover.
- Check the V-belt tension as 5. of 7.1 INSPECTION (P12).
- If V-belt tension becomes low, adjust to the proper V-belt tension by adjusting mounting position of DC power unit.
- If V-belt is damaged like cracks and wears, replace with new one.

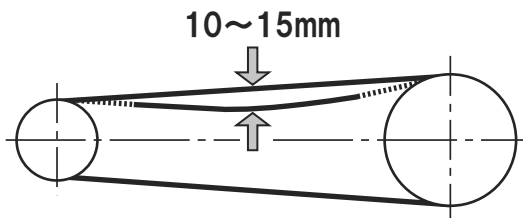

Fig.23

3. Checking the clutch

- Check the clutch simultaneously with V-belt checking. With belt removed, visually check outer drum of the clutch for seizure and "V" groove for wear or damage. Clean the "V" groove as necessary.
- Wear of lining or shoe should be checked regularly. If the shoe is worn, power transmission becomes deficient and slipping will result. Replace with new one.

4. Checking the engine bolt (fig. 24)

- Check the condition of engine bolt.
- If the engine bolt is damaged, worn and deformed, V-belt tension becomes low and DC power unit is damaged due to contact between the engine bolt and vibrating plate directly.
- Replace with new one when the thickness of rubber of engine bolt mount becomes 10mm or less.

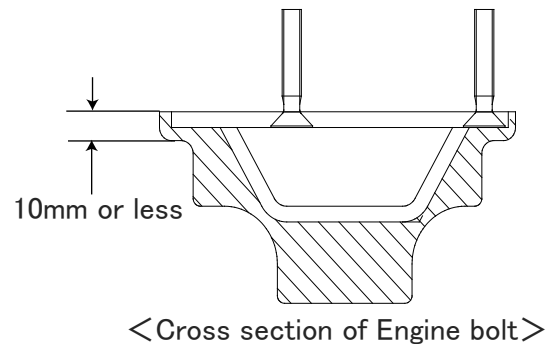

Fig.24

5. Checking the switch box (fig.25)

- Check that the assembling of switch box is not looseness.
- If the assembling of switch box is looseness, it may be damaged or fallen.
- Remove the switch box, then replace the grommet installed to switch box panel to new one (fig.25).

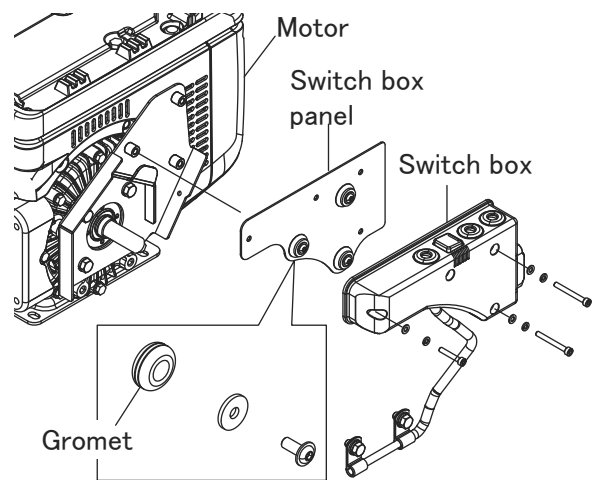

Fig.25

14. TROUBLESHOOTING

14.1 DC Power Unit, Battery Pack and Battery Charger

Regarding the troubleshooting of the DC Power Unit, Battery Pack and Battery Charger, please refer to each owner's manual.

14.2 Plate compactor

- DC Power Unit starts normally, but moving forward is not stable or it does not vibration.

- Bearing failure.
- Excessive vibrator oil.
- Clutch slips.
- V-belt slips or comes off.
- Vibrating plate wears or cracks.
- Shock absorbers wears or cracks.

15. WIRING DIAGRAM

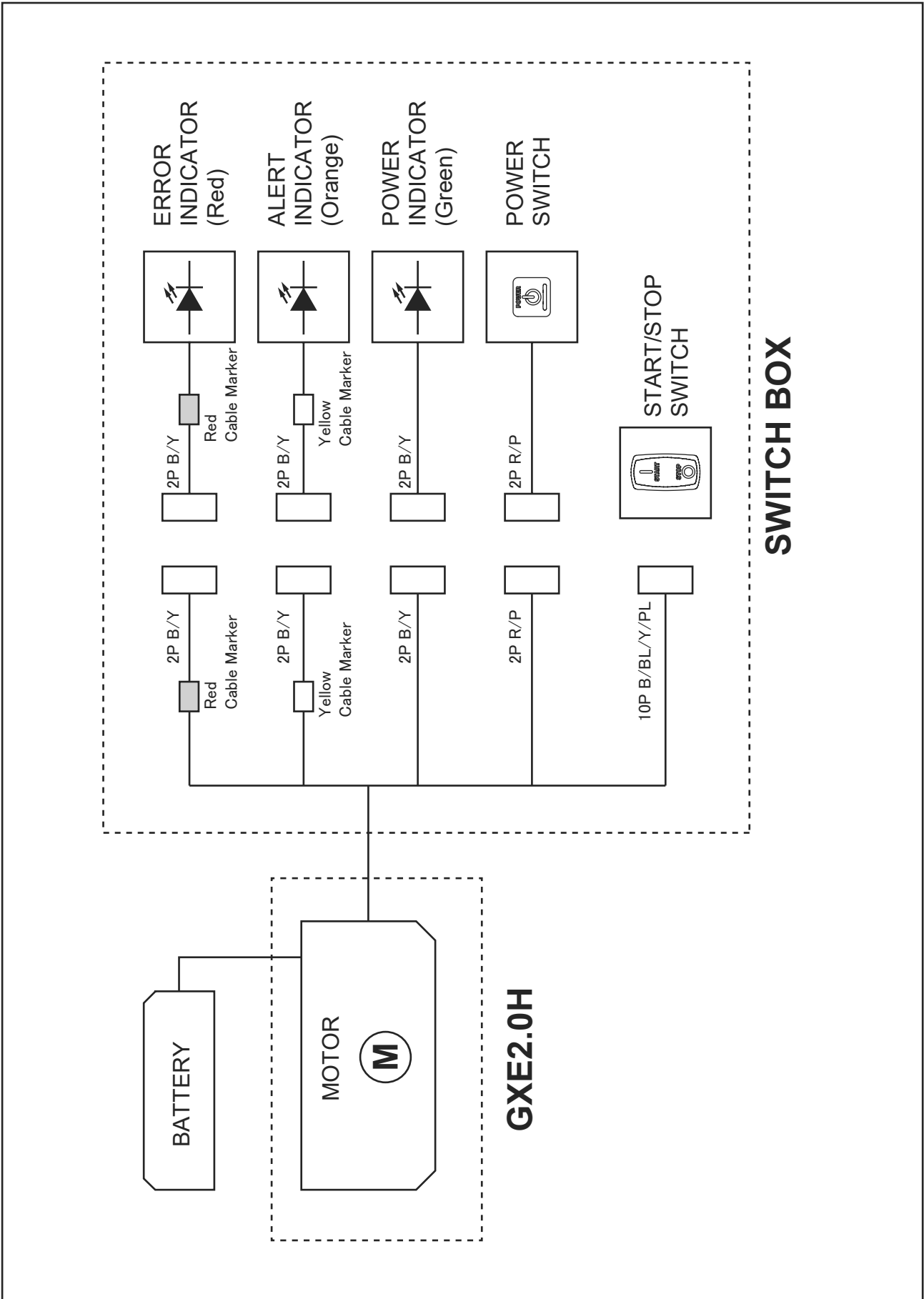

Mikasa

MIKASA SANGYO CO., LTD.

1-4-3, Kanda-Sarugakucho, Chiyoda-ku, Tokyo, 101-0064, Japan

PRINTED IN JAPAN



Parchem Construction Supplies Pty Ltd

1956 Dandenong Road, Clayton VIC 3168, Australia

Phone: 1300 353 986

flextool.com.au

ABN 80 069 961 968

This manual summarises our best knowledge of the product based on the information available at the time of publication. You should read this manual carefully and consider the information in the context of how the product will be used. Our responsibility for products sold is subject to our standard terms and conditions of sale.

DISCLAIMER:

Any advice, recommendation, information, assistance or service provided by us in this manual is given in good faith and is believed by us to be appropriate and reliable. However, any advice, recommendation, information, assistance or service provided by us is provided without liability or responsibility PROVIDED THAT the foregoing shall not exclude, limit, restrict or modify the right entitlements and remedies conferred upon any person or the liabilities imposed upon us by any condition or warranty implied by Commonwealth, State or Territory Act or ordinance void or prohibiting such exclusion limitation or modification. The product can be expected to perform as indicated in this manual so long as operation and operational procedures of the individual products are followed as recommended in this manual.

Design and technical specifications may be subject to changes.

© This publication is copyright. All rights are reserved. Flextool is a registered trade mark of Parchem Construction Supplies Pty Ltd. Mikasa is a registered trade mark of Mikasa Sangyo Co. Ltd, used under licence.

FOR MORE INFORMATION
CONTACT US ON **1300 353 986** OR VISIT flextool.com.au

EXCLUSIVE TO

