



SPARE PARTS MANUAL

MQ WHITEMAN RIDE-ON POWER TROWEL JWN24HTCSL, JWN24HSCSL



U.S. Revision #10 (07/09/24)
AUS Version 2.0 (November 2024)

FOR MORE INFORMATION VISIT flextool.com.au

EXCLUSIVE TO



PARTS MANUAL



WHITEMAN

MODELS

JWN24HTCSL

JWN24HSCSL

**RIDE-ON POWER TROWELS
(HONDA GX690RTAF GASOLINE ENGINE)**

S/N VB0206952 AND ABOVE

Revision #10 (07/09/24)

To find the latest revision of this publication or associated operation manual, visit our website at: www.multiquip.com



THIS MANUAL MUST ACCOMPANY THE EQUIPMENT AT ALL TIMES.

PN: 23625

**JWN24 Series
Ride-On Power Trowel**

Explanation of Code in Remarks Column..... 4
Suggested Spare Parts 5

Component Drawings

Nameplate and Decals Assembly..... 6-7
Seat/Frame Assembly 8-9
Pivot Assembly 10-11
Steering Control Assembly 12-13
Steering Handles Assembly..... 14-15
Gearbox Assembly (Right)..... 16-17
Gearbox Assembly (Left)..... 18-19
Pitch Control Tower/Yoke Assembly 20-21
Pitch Control Drive Cable Assembly..... 22-23
Drive Assembly..... 24-25
Engine Clutch Assembly..... 26-27
Spider Assembly (Left) 28-29
Spider Assembly (Right)..... 30-31
Foot Pedal/Throttle Assembly..... 32-33
Control Panel Assembly 34-35
Lights Assembly..... 36-37
Fuel Assembly 38-39
Battery Assembly..... 40-41
Engine and Muffler Assembly 42-43
Spray Assembly (S/N NF0210282 and Below) 44-45
Spray Assembly (S/N NH0210361 and Above) 46-47
Harness Assembly..... 48-49
Engine Service Parts 50-51

NOTICE
Specifications and part numbers are subject to change without notice.

EXPLANATION OF CODE IN REMARKS COLUMN

The following section explains the different symbols and remarks used in the Parts section of this manual. Use the help numbers found on the back page of the manual if there are any questions.

NOTICE

The contents and part numbers listed in the parts section are subject to change **without notice**. Multiquip does not guarantee the availability of the parts listed.

SAMPLE PARTS LIST

NO.	PART NO.	PART NAME	QTY.	REMARKS
1	12345	BOLT.....	1	INCLUDES ITEMS W/%
2%		WASHER, 1/4 IN.....		NOT SOLD SEPARATELY
2%	12347	WASHER, 3/8 IN....	1	MQ-45T ONLY
3	12348	HOSE	A/R	MAKE LOCALLY
4	12349	BEARING	1	S/N 2345B AND ABOVE

NO. Column

Unique Symbols — All items with same unique symbol

(@, #, +, %, or >) in the number column belong to the same assembly or kit, which is indicated by a note in the “Remarks” column.

Duplicate Item Numbers — Duplicate numbers indicate multiple part numbers, which are in effect for the same general item, such as different size saw blade guards in use or a part that has been updated on newer versions of the same machine.

NOTICE

When ordering a part that has more than one item number listed, check the remarks column for help in determining the proper part to order.

PART NO. Column

Numbers Used — Part numbers can be indicated by a number, a blank entry, or TBD.

TBD (To Be Determined) is generally used to show a part that has not been assigned a formal part number at the time of publication.

A blank entry generally indicates that the item is not sold separately or is not sold by Multiquip. Other entries will be clarified in the “Remarks” Column.

QTY. Column

Numbers Used — Item quantity can be indicated by a number, a blank entry, or A/R.

A/R (As Required) is generally used for hoses or other parts that are sold in bulk and cut to length.

A blank entry generally indicates that the item is not sold separately. Other entries will be clarified in the “Remarks” Column.

REMARKS Column

Some of the most common notes found in the “Remarks” Column are listed below. Other additional notes needed to describe the item can also be shown.

Assembly/Kit — All items on the parts list with the same unique symbol will be included when this item is purchased.

Indicated by:

“INCLUDES ITEMS W/(unique symbol)”

Serial Number Break — Used to list an effective serial number range where a particular part is used.

Indicated by:

“S/N XXXXX AND BELOW”

“S/N XXXX AND ABOVE”

“S/N XXXX TO S/N XXX”

Specific Model Number Use — Indicates that the part is used only with the specific model number or model number variant listed. It can also be used to show a part is NOT used on a specific model or model number variant.

Indicated by:

“XXXXX ONLY”

“NOT USED ON XXXX”

“Make/Obtain Locally” — Indicates that the part can be purchased at any hardware shop or made out of available items. Examples include battery cables, shims, and certain washers and nuts.

“Not Sold Separately” — Indicates that an item cannot be purchased as a separate item and is either part of an assembly/kit that can be purchased, or is not available for sale through Multiquip.

SUGGESTED SPARE PARTS

JWN24 SERIES RIDE-ON TROWEL

1 to 3 units

Qty.	P/N	Description
4	20409-1	TROWEL ARM, (L.S.)
4	20408-1	TROWEL ARM, (R.S.)
4	1163-1	LEVER TROWEL ARM (R.S.)
4	1555-1	LEVER TROWEL ARM (L.S.)
2	10968	THRUST COLLAR KIT
2	20369	SPIDER ASSY., 4-BLADE (L.S.)
2	20370	SPIDER ASSY., 4-BLADE (R.S.)
4	1157 A	BUSHING, SPIDER
1	23513	BELT, DRIVE CVT
1	23514	FUEL CAP/GAUGE (ENGINE)
1	23518	CABLE, THROTTLE (FOOT PEDAL)
6	2064	ROD END, FEM RH 3/8-24 (STEERING)
4	2063	ROD END, MALE RH 3/8-24 (STEERING)
2	11142	ROD END, MALE RH 1/2-20 (STEERING)
10	10031	WASHER 1/4 IN.
1	392292	SPRAY NOZZLE
1	29509	CAP, SPRAY TANK
1	406000	ROCKER SWITCH (LIGHTS)
1	21870	KILL SWITCH, (SEAT)
1	12017	RELAY, KILL (SEAT)
3	20111	OIL, GEARBOX
1	2618	GASKET AND SEAL KIT (GB)
1	2619	BEARING KIT (GEARBOX)
2	23284-030	FUSE, 3A
2	23284-150	FUSE, 15A
2	982004300	FUSE, 30A
2	32640	LED, 20W, OVAL
4	BLADE ASSY.	CONTACT UNIT SALES DEPT/ACCESSORY ITEM

HONDA GX690RTAF-R280 24 HP ENGINE

1 to 3 units

Qty.	P/N	Description
1	39700Z6L003	HOUR METER
2	17210Z6L010	ELEMENT COMP.
1	17218Z6L000	FILTER, OUTER
2	16910Z6L003	FILTER, INLINE FUEL
1	35110ZV5V501	KEY, IGNITION
1	37240ZG5004	SWITCH, OIL PRESSURE
3	15400PLMA01PE	CARTRIDGE, OIL FILTER
4	980795587G	SPARK PLUG

NOTICE

Part numbers on this Suggested Spare Parts list may supersede/replace the part numbers shown in the following parts lists.

NAMEPLATE AND DECALS ASSY.

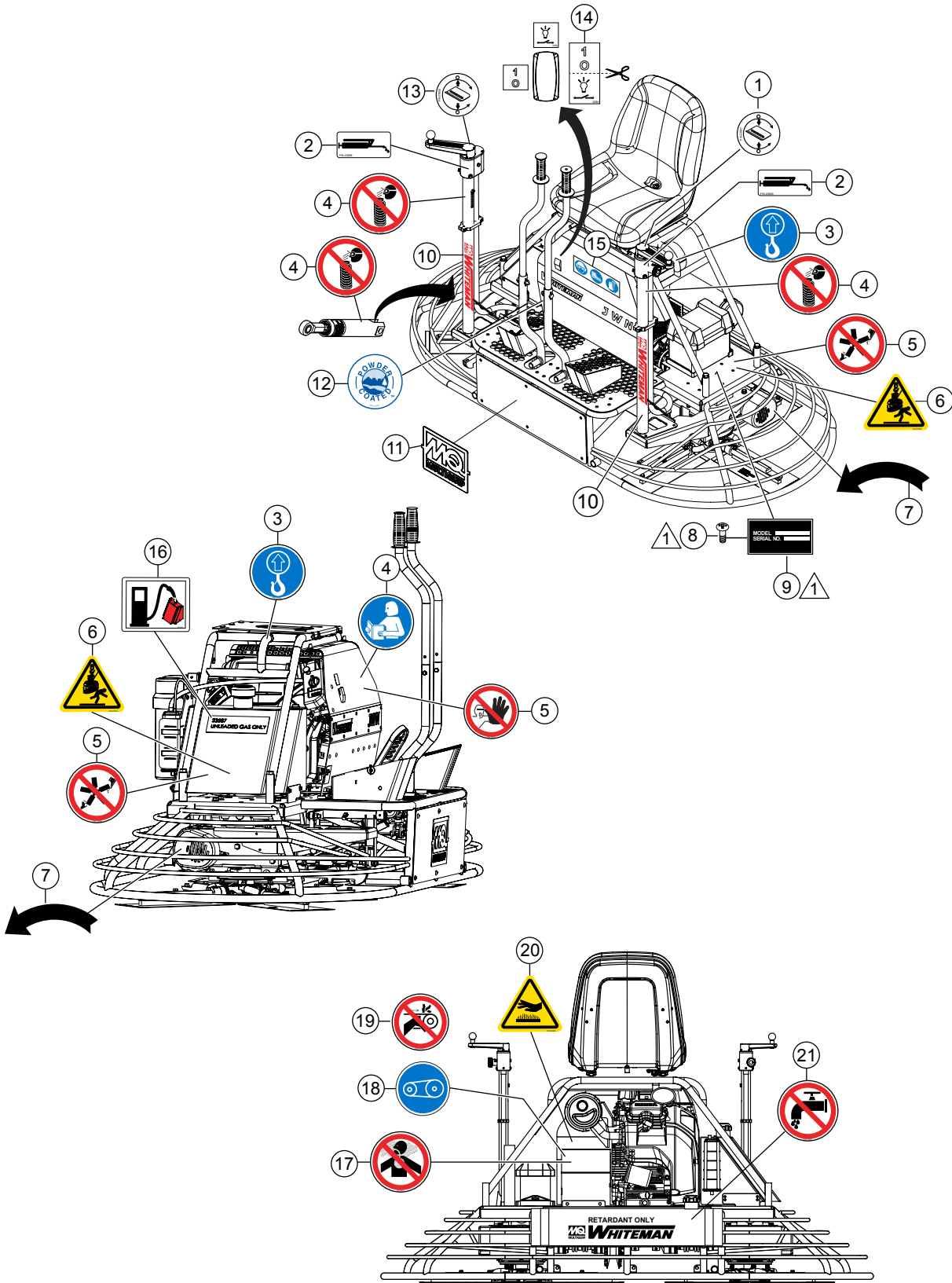

NAMEPLATE AND DECALS ASSY.

<u>NO.</u>	<u>PART NO.</u>	<u>PART NAME</u>	<u>QTY.</u>	<u>REMARKS</u>
1	23807	DECAL ISO, PITCH, LH 2.00" DIA	1	
2	23809	DECAL ISO, LUBRICATION POINT	2	
3	23805	DECAL ISO, LIFT LOCATION 1.00" DIA	2	
4	23804	DECAL ISO, DO NOT DISASSEMBLE, CYLINDER	3	
5	23698	DECAL ISO, ROTATING BLADE HAZARD	2	
6	23700	DECAL ISO, LIFTING / CRUSH HAZARD	2	
7	25678	DECAL ISO, BLADE ROTATION CCW	2	
8	4014	SCREW,#2, 3/16 P-K TYPE U DRIVE	2	
9		SERIAL PLATE	1 CONTACTMQPARTS DEPT.
10	21589	DECAL, WHITEMAN SERIES 4.76 X 21.82, WHT	2	
11	23235	BADGE, FOOT PLATFORM	1	
12	13118	DECAL, POWDER COATED	1	
13	23806	DECAL ISO, PITCH, RH 2.00" DIA	1	
14	32554	DECAL, LIGHT SWITCH	1	
15	36099	DECAL, ISO PROTECTIVE CLOTHING	1	
16	23812	DECAL ISO, FUEL GASOLINE 3.0" X 2.45"	1	
17	23810	DECAL ISO, INHALATION HAZARD, 2"	1	
18	32553	DECAL, BELT DRIVE	1	
19	23704	DECAL ISO, GUARD WARNING	1	
20	23808	DECAL ISO, HOT SURFACE HAZARD	1	
21	23811	DECAL ISO, NO WATER WARNING, 2.0" DIA	1	

SEAT/FRAME ASSY.

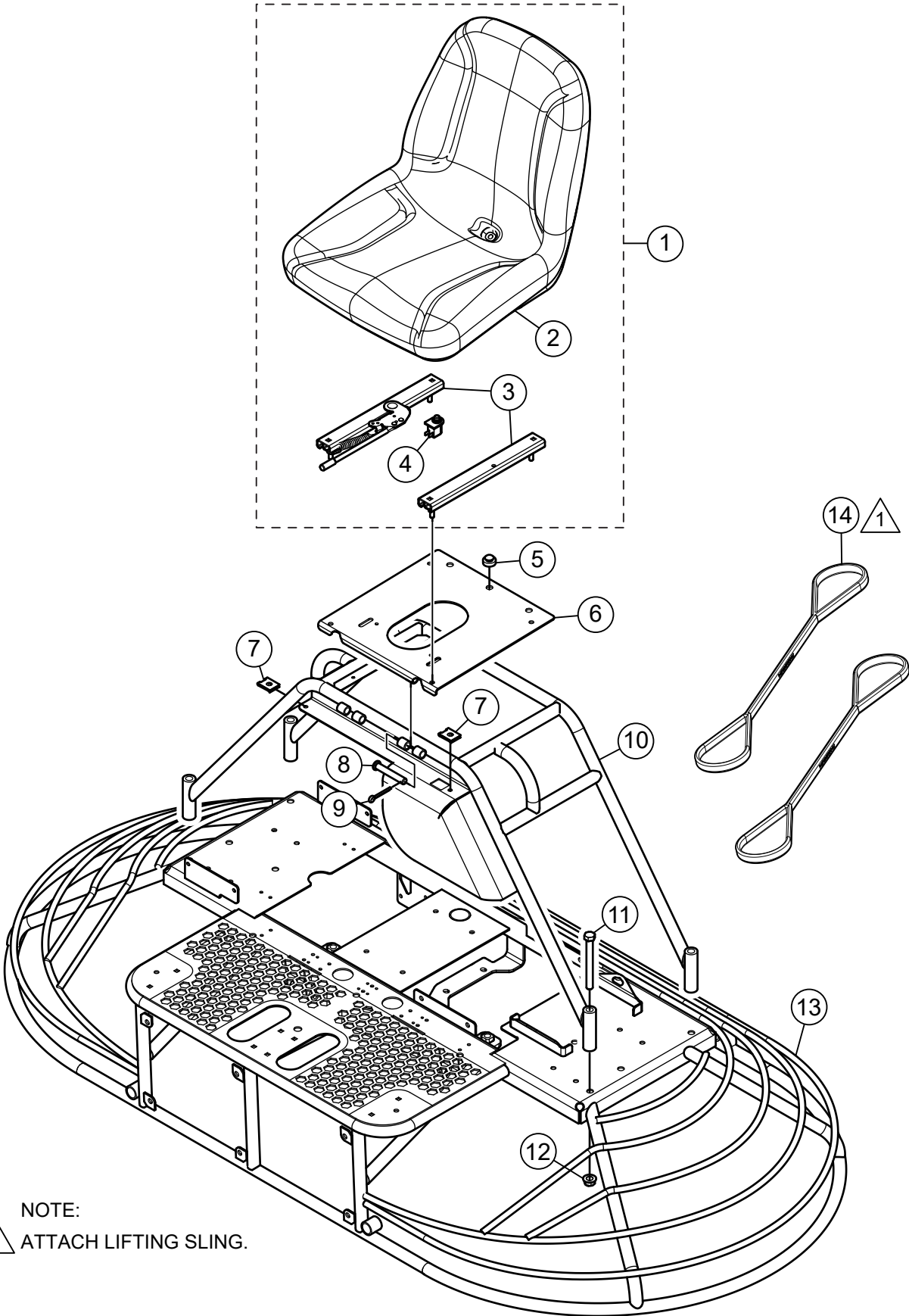

NOTE:
1 ATTACH LIFTING SLING.

SEAT/FRAME ASSY.

<u>NO.</u>	<u>PART NO.</u>	<u>PART NAME</u>	<u>QTY.</u>	<u>REMARKS</u>
1	21861	SEAT,MICHIGAN-ADJUSTABLE W/O ARMS.....1.....	1	INCLUDES ITEMS W/#
2#	21860	SEAT,BASIC-MICHIGAN V-2805 SERIES	1	
3#	21865	ADJUSTER KIT,SEAT-MICHIGAN V-2805	1	
4#	21870	KILL SWITCH,SEAT-DELTA SYS 6440-62	1	
5	21597	BUMPER,STEM 1" DIA x .5 S DIA x 19/64TK	3	
6	23522	SEAT PLATE WA - JWN	1	
7	21894	CLIP, FAST LEAD-SOUTHCO 17-10027-17	2	
8	8081	PIN, CLEVIS 1/2 X 2-3/4"	2	
9	0183	PIN, COTTER 1/8Dx1-1/4"	2	
10	23527	SEAT FRAME WA, JWN	1	
11	913222	SCREW, HHC 1/2-13 x 4-3/4"	4	
12	26328	NUT, FLANGED 1/2-13 SERRATED PLTD	4	
13	23501	FRAME, JWN , COMPLETE W/A	1	
14	23165	SLING, LIFTING	2	

PIVOT ASSY.

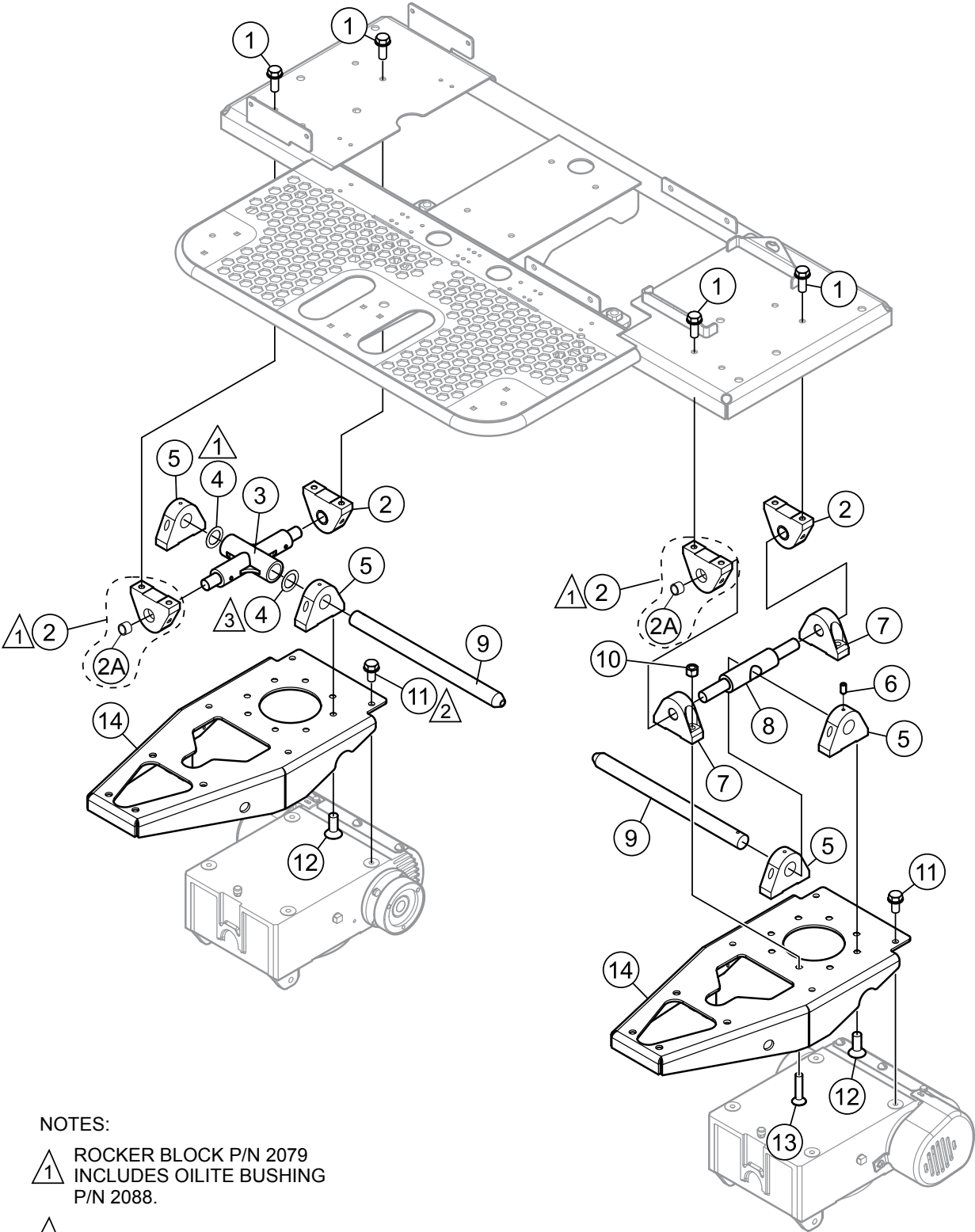

NOTES:

- △ 1 ROCKER BLOCK P/N 2079
INCLUDES OILITE BUSHING
P/N 2088.
- △ 2 BOLT TO GEARBOX
- △ 3 USE SHIMS AS REQUIRED TO
MINIMIZE LATERAL MOVEMENT
OF PIVOT ARMS.

PIVOT ASSY.

<u>NO.</u>	<u>PART NO.</u>	<u>PART NAME</u>	<u>QTY.</u>	<u>REMARKS</u>
1	22106	SCREW, HHFS 3/8-16 x 1.25" ZINC	8	
2	2079	ROCKER BLOCK WITH BUSHING.....	4.....	INCLUDES ITEM W/#
2A#	2088	BUSHING, FLANGE .875 DIA X.75 ID X 1.00	4	
3	2044	ARM, PIVOT J TROWELS RH	1	
4	11772	SHIM, STEEL .63xØ1.500ODxØ1.000ID	A/R	
4	11773	SHIM, STEEL .031xØ1.500ODxØ1.000ID	A/R	
5	20040	ROCKER BLOCK, 1.0 HOLE	4	
6	10138	SCREW, SHS 1/4-20 X 1/2", N.P.	4	
7	10973	ROCKER BLOCK W/FAN	2	
8	2076	TUBE, PIVOT	1	
9	2824	TUBE, CONTROL PIVOT 1"	2	
10	10133	NUT, NYLOC 3/8-16	4	
11	38274	SCREW, HHFS 3/8-16 X .75" ZINC	8	
12	1394	SCREW, FHSC 3/8-16 X 1"	8	
13	1481	SCREW, FHSC 3/8-16 X 1-3/4" PLATED	4	
14	23475	MOUNT, JWN GBOX	2	

STEERING CONTROL ASSY.

NOTES:

2 REFERENCE STEERING HANDLES ASSY. ON NEXT PAGE.

3 LOWER RIGHT-SIDE STEERING CONTROL ASSY. IS THE SAME AS LEFT-SIDE STEERING CONTROL ASSY.

4 COMPRESS SPRING TO:
4.90 ~ 4.80 IN.
12.4 ~ 12.1 CM.

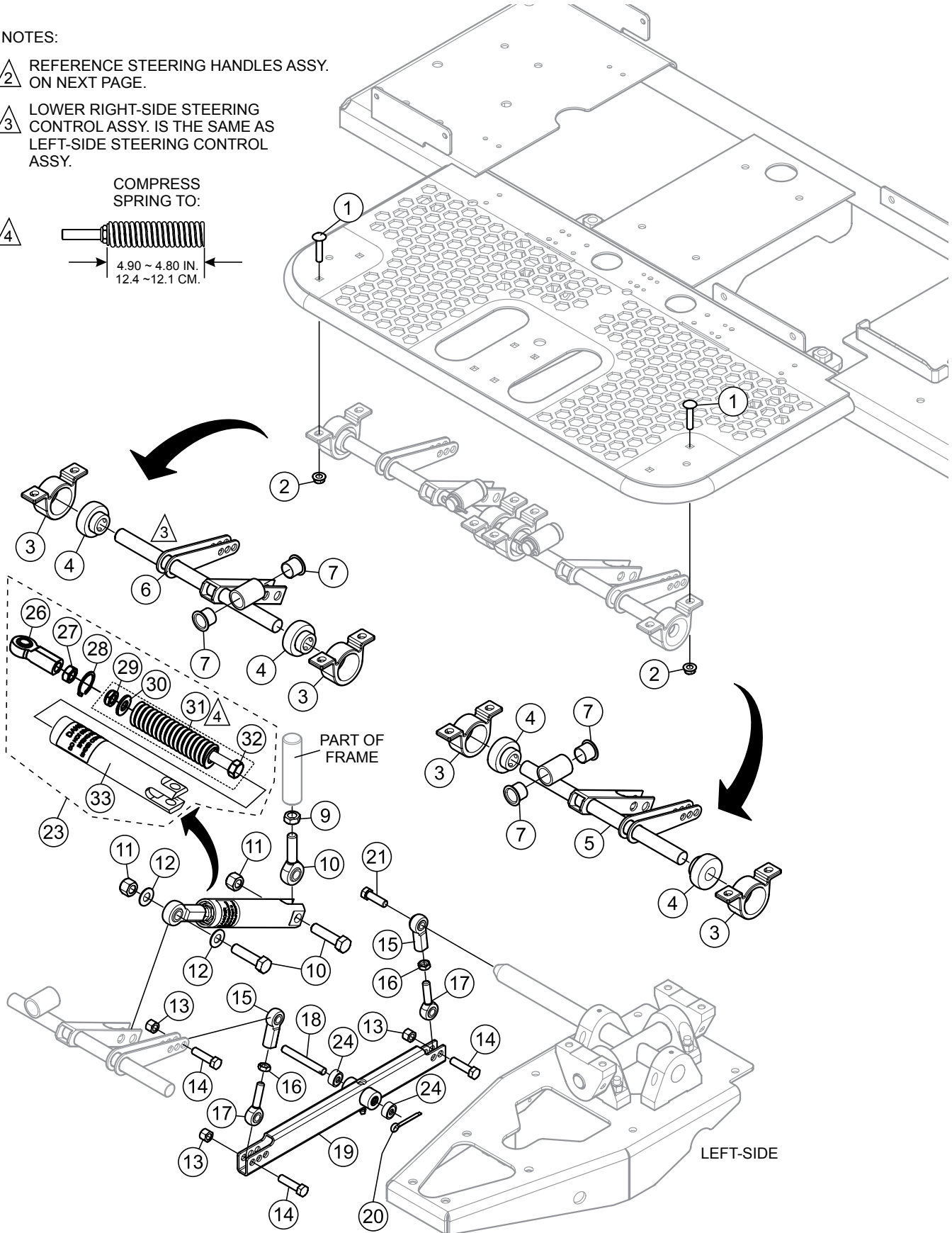

STEERING CONTROL ASSY.

<u>NO.</u>	<u>PART NO.</u>	<u>PART NAME</u>	<u>QTY.</u>	<u>REMARKS</u>
1#	07046-011	BOLT, CARRIAGE 5/16-18 X 1.5" gr5, ZINC	8	
2#	49071	NUT, FLANGED 5/16-18 SERRATED PLTD	8	
3#	11138	BEARING, SB-204-12, HOUSING	4	
4#	11149	BEARING, SB-204-12, INSERT	4	
5#	12650	STEERING CONTROL, LEFT SIDE	1	
6#	12651	STEERING CONTROL, RIGHT SIDE	1	
7#	12408	BUSHING, GARLOCK 12FDU12	4	
9#	11146	NUT, HEX JAM 1/2-20 PLATED	2	
10#	11142	ROD END, 1/2-20 MALE RH	2	
11#	10176	NUT, NYLOC 1/2-13	4	
12#	9094	SPACER, STEERING ASSIST CLEVIS	4	
13#	10133	NUT, NYLOC 3/8-16	6	
14#	1284	SCREW, HHC 3/8-16 X 1-1/2"	6	
15#	2064	ROD END, 3/8-24 FEMAL RH	4	
16#	2199	NUT, HEX JAM 3/8-24	4	
17#	2063	ROD END, 3/8-24 MALE RH	4	
18#	11275	3/8 DIA X 3 DIAMOND CHAIN 100-2	2	
19#	11071	LEVER, STEERING CONTROL	2	
20#	6014 B	PIN, COTTER 3/32DX1.00	2	
21#	1023	SCREW, HHC 3/8-16 X 1-1/4" GR 5	2	
23#	12625	STEERING ASSIST, ASSY.	1	INCLUDES ITEMS W/%
24#	11072	BEARING, TORRINGTON JT69	4	
25#	7798	STEERING ASSY.....	1	INCLUDES ITEMS W/#
26%	11143	ROD END, 1/2-20 FEMALE RH	1	
27%	11146	NUT, HEX JAM 1/2-20 PLATED	1	
28%	12197	SNAP RING Ø1.25	1	
29%	10087	NUT, NYLOC, JAM 1/2-13	1	
30%	0447	WASHER, FLAT 1/2 SAE	1	
31%	12624	SPRING, STEERING ASSIST	1	
32%	12198	SCREW, HHC 1/2-20 X 7" TAP	1	
33%	12195	HOUSING, STEERING ASSIST SPRING	1	

STEERING HANDLES ASSY.

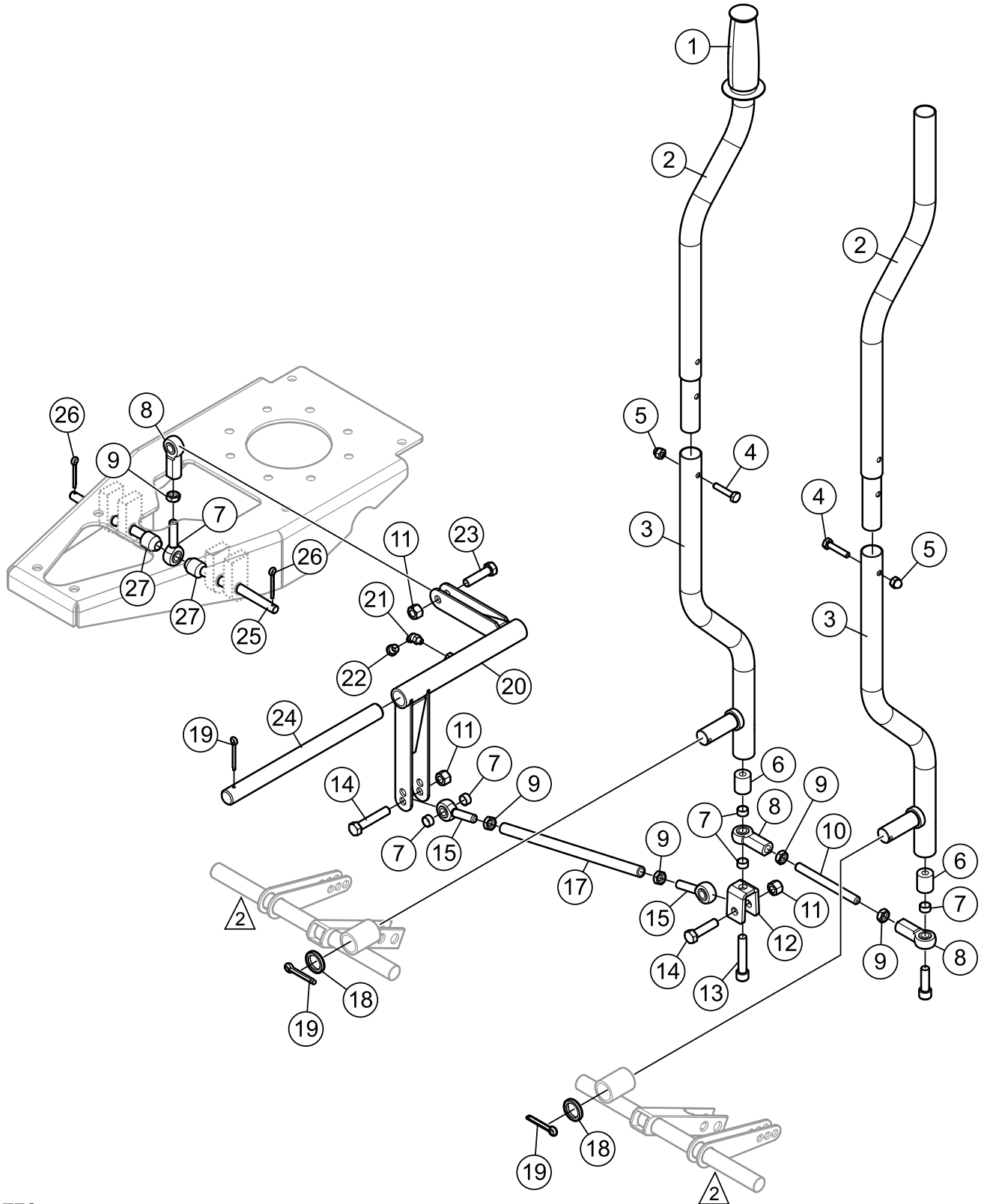

NOTES:

 REFERENCE STEERING CONTROL ASSY. ON PREVIOUS PAGE., ITEMS 5 AND 6.

STEERING HANDLES ASSY.

<u>NO.</u>	<u>PART NO.</u>	<u>PART NAME</u>	<u>QTY.</u>	<u>REMARKS</u>
1#	20478	GRIP, HANDLE	1	
2#	10130	HANDLE TUBE	2	
3#	11079	HANDLE, LOWER	2	
4#	0424	SCREW, HHC 1/4-20 X 1-1/4"	2	
5#	2197	NUT, ACORN 1/4-20	2	
6#	11080	PLUG, LOWER HANDLE	2	
7#	2196	SPACER, 0.5 X 0.402 X .25L	5	
8#	2064	ROD END, 3/8-24 FEMAL RH	3	
9#	2199	NUT, HEX JAM 3/8-24	5	
10#	11498	THREADPIECE, CONN. STEERING	1	
11#	10133	NUT, NYLOC 3/8-16	3	
12#	11303	BRACKET, L/R MOTION ROD	1	
13#	11089	SCREW, SHC 3/8-16 X 2" PLATED	1	
14#	1665	SCREW, HHC 3/8-16 X 2"	2	
15#	2063	ROD END, 3/8-24 MALE RH	3	
17#	11513	ROD, L/R, LINKAGE	1	
18#	11265	WASHER, STEERING HANDLE 1.0 OD X .75 ID X .14	2	
19#	2219	PIN, COTTER 1/8DX1-1/2	3	
20#	11441	RIGHT-LEFT MOTION CONTROL ARM	1	
21#	5228	FITTING, GREASE ZERK 45 DEG 1/4-28	1	
22#	1162 A	CAP, GREASE ZERK, #2 YELLOW	1	
23#	1665	SCREW, HHC 3/8-16 X 2	1	
24#	11497	SHAFT, L/R, MOTION LEVER	1	
25#	3550	PIN, 3/8 DIA X 5-7/8 LONG	1	
26#	6014 B	PIN, COTTER 3/32DX1.00	2	
27#	2188	SPACER	2	

GEARBOX ASSY. (RIGHT)

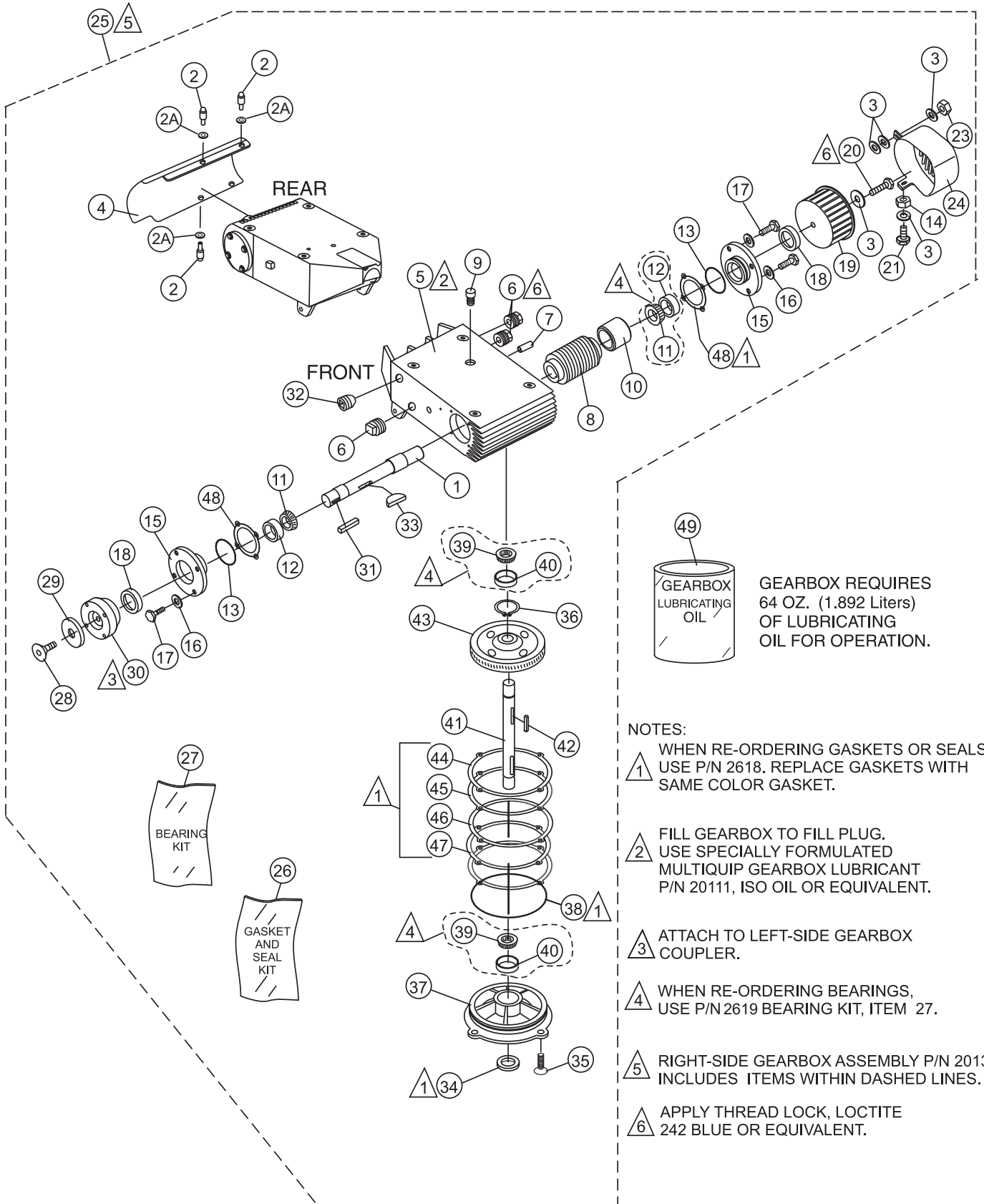

GEARBOX LUBRICATING OIL

GEARBOX REQUIRES 64 OZ. (1.892 Liters) OF LUBRICATING OIL FOR OPERATION.

- NOTES:
- 1 WHEN RE-ORDERING GASKETS OR SEALS USE P/N 2618. REPLACE GASKETS WITH SAME COLOR GASKET.
 - 2 FILL GEARBOX TO FILL PLUG. USE SPECIALLY FORMULATED MULTIQUIP GEARBOX LUBRICANT P/N 20111, ISO OIL OR EQUIVALENT.
 - 3 ATTACH TO LEFT-SIDE GEARBOX COUPLER.
 - 4 WHEN RE-ORDERING BEARINGS, USE P/N 2619 BEARING KIT, ITEM 27.
 - 5 RIGHT-SIDE GEARBOX ASSEMBLY P/N 20134 INCLUDES ITEMS WITHIN DASHED LINES.
 - 6 APPLY THREAD LOCK, LOCTITE 242 BLUE OR EQUIVALENT.

GEARBOX ASSY. (RIGHT)

<u>NO.</u>	<u>PART NO.</u>	<u>PART NAME</u>	<u>QTY.</u>	<u>REMARKS</u>
1%	20065	SHAFT, GEARBOX INPUT W/FAN	1	
2%	19847	RIVET, POP BH .187 X .125-.250 GRIP AL/STL	4	
2A%	29342	WASHER, POP RIVET BACKUP 3/16 DIA. SS	4	
3%	0948	WASHER, FLAT, 1/4 SAE	6	
4%	12981	SHROUD, GB FIN COVER, RIGHT	1	
5%	20353	GEAR BOX 1-1/8 SHAFT	1	
6%	0121A	FITTING, PLUG 3/8MP SQUARE HEAD	3	
7%	10989	STUD, N10- 32 X 3/4	1	
8%	12908	RIGHT HAND WORM	1	
9%	1132	VENT, AIR	1	
10%	12583	SPACER, X 11D X 1.168L	1	
11%+	9045	BEARING, CONE TIMKEN #1986	1	
12%+	0232A	BEARING, CUP, TIMKEN #1932	1	
13%#	2309	O-RING, 2-13/16" VINTON	1	
14%	0937	NUT, HEX #10- 32	1	
15%	2307	FLANGE, COUNTERSHAFT	1	
16%	10031	WASHER, EXT SHKP 1/4	8	
17%	2295	SCREW, HHC 1/4- 20 X 7/8"	8	
18%	12909	SEAL, OIL, NATIONAL #471689V	1	
19%	10921	FAN, RIGHT SIDE	1	
20%	0424	SCREW, HHC 1/4- 20 X 1-1/4"	1	
21%	19477	SCREW, HHC, WASHER 10- 32 X 1/2"	1	
23%	10019	NUT, NYLOC 10- 32	1	
24%	10894	RIGHT SIDE FAN COVER	1	
25%	20134	GEARBOX ASSY., RS W/FAN	1	INCLUDES ITEMS W/%
26%	2618	GASKET AND SEAL KIT	1	INCLUDES ITEMS W/#
27%	2619	BEARING KIT	1	
28%	1313	SCREW, FHSC 3/8- 24 X 3/4" PLAIN	1	
29%	9120	RETAINER, DRIVEN PULLEY	1	
30%	2048	COUPLER- 7/8" ID	1	
31%	2323	KEY, 1/4 X 1/4 X 13/16"	1	
32%	10450	SCREW, SHS 10- 32 X 1/4"	1	
33%	1139	KEY, WOODRUFF #21 HARDENED	1	
34%#	9041	SEAL, 1-1/8 DIA NAT # 471763V	1	
35%	1146	SCREW, FHS 5/16- 18 X 1" NYLOC	4	
36%	1138	RING, SNAP TRUARC #5100- 112	1	
37%	9036	COVER, GEARBOX 1-1/8 SHAFT	1	
38%#	9038	O-RING, A- 264 VITON	1	
39%	0232	BEARING, CONE TIMKEN #15126	2	
40%	0232A	BEARING, CUP, TIMKEN #1932	2	
41%	20013	SHAFT, OUTPUT HD GEARBOX	1	
42%	9180	KEY, 5/16 X 2-1/4" HRDND	1	
43%	9181	GEAR, WORM RH. HD	1	
44%#		GASKET, RED	1	SOLD AS KIT ONLY
45%#		GASKET, GREEN	1	SOLD AS KIT ONLY
46%#		GASKET, BLUE	1	SOLD AS KIT ONLY
47%#		GASKET, BROWN	1	SOLD AS KIT ONLY
48%#		GASKET, YELLOW	1	SOLD AS KIT ONLY
49	20111	OIL, MOBIL SHC 634 ISO VG640, 24 OZ.	AR	

GEARBOX ASSY. (LEFT)

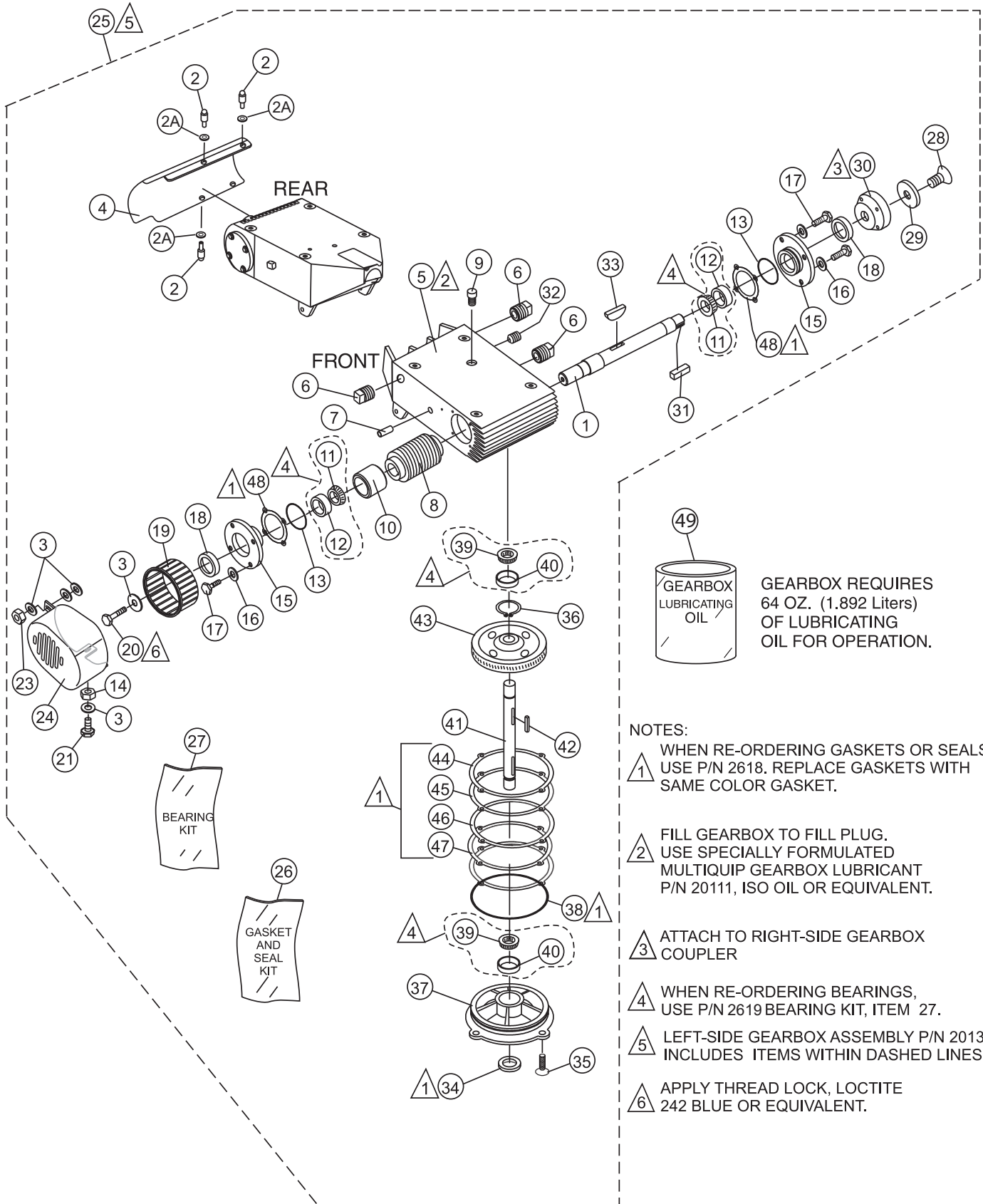

GEARBOX REQUIRES
64 OZ. (1.892 Liters)
OF LUBRICATING
OIL FOR OPERATION.

- NOTES:
- ① WHEN RE-ORDERING GASKETS OR SEALS USE P/N 2618. REPLACE GASKETS WITH SAME COLOR GASKET.
 - ② FILL GEARBOX TO FILL PLUG. USE SPECIALLY FORMULATED MULTIQUIP GEARBOX LUBRICANT P/N 20111, ISO OIL OR EQUIVALENT.
 - ③ ATTACH TO RIGHT-SIDE GEARBOX COUPLER
 - ④ WHEN RE-ORDERING BEARINGS, USE P/N 2619 BEARING KIT, ITEM 27.
 - ⑤ LEFT-SIDE GEARBOX ASSEMBLY P/N 20133 INCLUDES ITEMS WITHIN DASHED LINES.
 - ⑥ APPLY THREAD LOCK, LOCTITE 242 BLUE OR EQUIVALENT.

GEARBOX ASSY. (LEFT)

<u>NO.</u>	<u>PART NO.</u>	<u>PART NAME</u>	<u>QTY.</u>	<u>REMARKS</u>
1%	20065	SHAFT, GEARBOX INPUT W/FAN	1	
2%	19847	RIVET, POP BH .187 X .125-.250 GRIP AL/STL	4	
2A%	29342	WASHER, POP RIVET BACKUP 3/16 DIA. SS	4	
3%	0948	WASHER, FLAT, 1/4 SAE	6	
4%	12982	SHROUD, GB FIN COVER, LEFT	1	
5%	20353	GEAR BOX 1-1/8 SHAFT	1	
6%	0121A	FITTING, PLUG 3/8MP SQUARE HEAD	3	
7%	10989	STUD, N10- 32 X 3/4	1	
8%	12907	LEFT HAND WORM	1	
9%	1132	VENT, AIR	1	
10%	12583	SPACER, X 11D X 1.168L	1	
11%+	9045	BEARING, CONE TIMKEN #1986	1	
12%+	0232A	BEARING, CUP, TIMKEN #1932	1	
13%#	2309	O-RING, 2-13/16" VINTON	1	
14%	0937	NUT, HEX #10- 32	1	
15%	2307	FLANGE, COUNTERSHAFT	1	
16%	10031	WASHER, EXT SHKP 1/4	4	
17%	2295	SCREW, HHC 1/4- 20 X 7/8"	4	
18%	12909	SEAL, OIL, NATIONAL #471689V	1	
19%	10922	FAN, LEFT SIDE	1	
20%	0424	SCREW, HHC 1/4- 20 X 1-1/4"	1	
21%	19477	SCREW, HHC, WASHER 10- 32 X 1/2"	1	
23%	10019	NUT, NYLOC 10- 32	1	
24%	10893	LEFT SIDE FAN COVER	1	
25	20133	GEARBOX ASSY., LS W/FAN	1	INCLUDES ITEMS W/%
26%	2618	GASKET AND SEAL KIT	1	INCLUDES ITEMS W/#
27%	2619	BEARING KIT	1	
28%	1313	SCREW, FHSC 3/8- 24 X 3/4 PLAIN	1	
29%	9120	RETAINER, DRIVEN PULLEY	1	
30%	2048	COUPLER- 7/8" ID	1	
31%	2323	KEY, 1/4 X 1/4 X 13/16"	1	
32%	10450	SCREW, SHS 10- 32 X 1/4"	1	
33%	1139	KEY, WOODRUFF #21 HARDENED	1	
34%#	9041	SEAL, 1-1/8 DIA NAT # 471763V	1	
35%	1146	SCREW, FHS 5/16- 18 X 1" NYLOC	4	
36%	1138	RING, SNAP TRUARC #5100- 112	1	
37%	9036	COVER, GEARBOX 1-1/8 SHAFT	1	
38%#	9038	O-RING, A- 264 VITON	1	
39%	0232	BEARING, CONE TIMKEN #15126	2	
40%	0232A	BEARING, CUP, TIMKEN #1932	2	
41%	20013	SHAFT, OUTPUT HD GEARBOX	1	
42%	9180	KEY, 5/16 X 2-1/4" HRDND	1	
43%	2001	GEAR, WORM LH. HD	1	
44%#		GASKET, RED	1	SOLD AS KIT ONLY
45%#		GASKET, GREEN	1	SOLD AS KIT ONLY
46%#		GASKET, BLUE	1	SOLD AS KIT ONLY
47%#		GASKET, BROWN	1	SOLD AS KIT ONLY
48%#		GASKET, YELLOW	2	SOLD AS KIT ONLY
49	20111	OIL, MOBIL SHC 634 ISO VG640, 24 OZ.	AR	

PITCH CONTROL TOWER/YOKE ASSY.

NOTES:

- 1 LEVER ASSEMBLY, ITEM 37
INCLUDES ITEMS WITHIN OUTLINE.
- 2 KNOB KIT P/N 2737 (ITEM 38)
INCLUDES ITEMS 26, 27, 31, AND 32.
- 3 RIGHT SIDE PITCH LEVER IS
IDENTICAL TO LEFT SIDE
PITCH LEVER UNLESS
OTHERWISE NOTED.

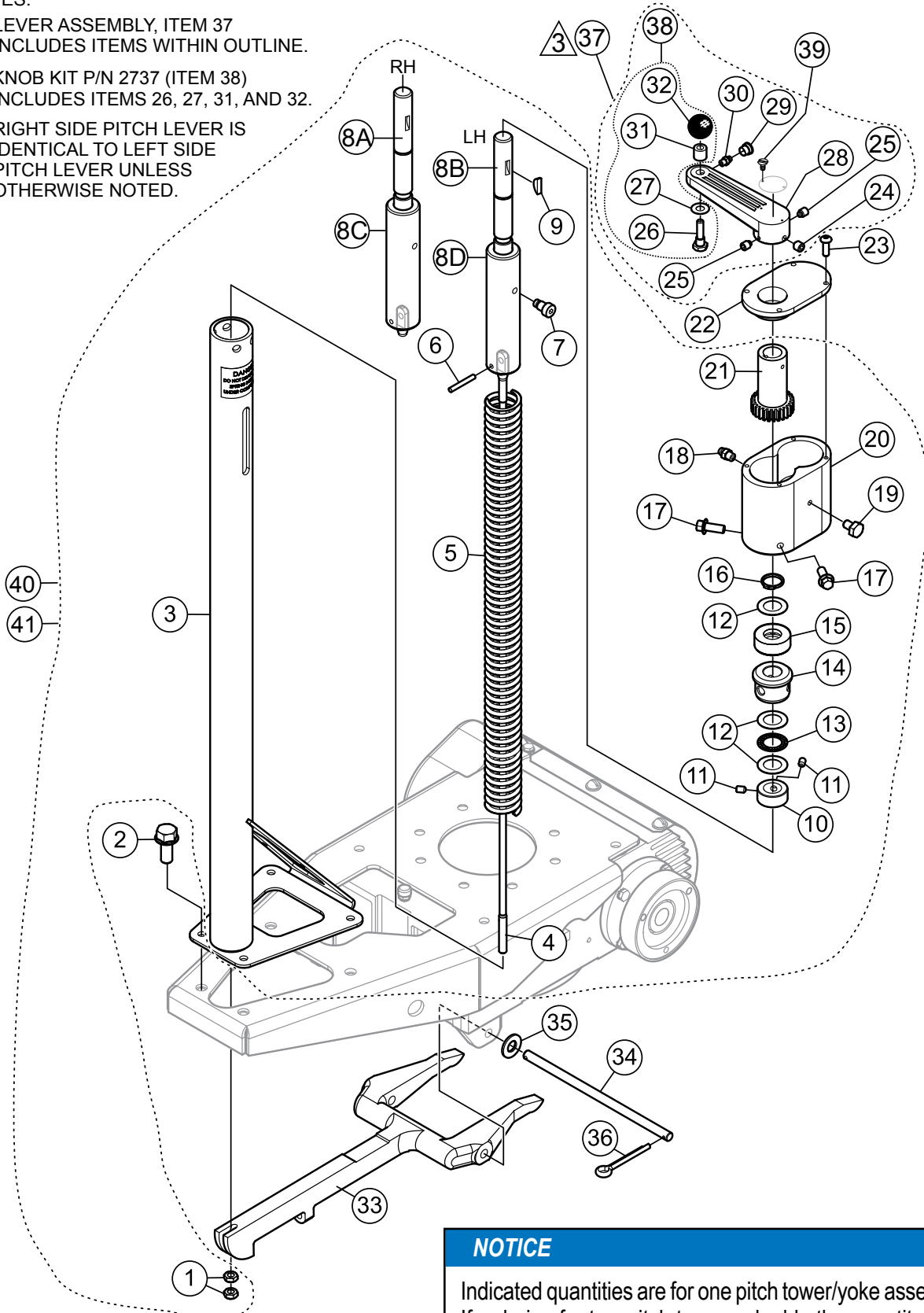

NOTICE
Indicated quantities are for one pitch tower/yoke assembly.
If ordering for two pitch towers, double the quantity.

PITCH CONTROL TOWER/YOKE ASSY.

<u>NO.</u>	<u>PART NO.</u>	<u>PART NAME</u>	<u>QTY.</u>	<u>REMARKS</u>
1	1116	NUT, BRASS JAM 5/16-18	2	
2	36720	SCREW, HHFS 5/16-18 x 3/4" GR5	4	
3	23582	TOWER W/A, PITCH CONTROL , RH	1	RIGHT
3	23581	TOWER W/A, PITCH CONTROL, LH.....	1	LEFT
4	2008	CABLE, TWIN PITCH, 25.63"	1	
5	2156	SPRING, COMPRESSION, 15/16" ODX20-5/8" LEN.	1	
6	10723	PIN, SPIRAL 3/16 X 1-3/8 HD	1	
7	10382	BOLT, SHOULDER, 3/8 X 3/8 LONG	1	
8A	10510	SHAFT, PITCH CONTROL, RH	1	
8B	10511	SHAFT, PITCH CONTROL, LH	1	
8C	10721	BLOCK, SLIDE RH PITCH CONTROL TUBE	1	
8D	10722	BLOCK, SLIDE LH PITCH CONTROL TUBE	1	
9	0126	KEY, WOODRUFF #606 3/16 x 3/4 (#9)	1	
10%	2367	COLLAR, SET .75 X 1.25 X .56, 2	1	
11		SET SCREW	2	INCLUDESITEMW/%
12	2170	BEARING, RACE, TORR. #TRA1220	3	
13	2169	BEARING, THRUST, TORR. #NTA1220	1	
14	1612	BEARING TROWEL CONTROL	1	
15	1604	BEARING, BALL THRUST E5 AETNA	1	
16	10512	RING, SNAP, TRUARC 5160-75	1	
17	22021	SCREW, HEX FLANGE M8-1.25 x 20MM GR10.9	2	
18	2621	FITTING, GREASE ZERK STR 1/4-28	1	
19	20476	SCREW, HHC 1/4-28 X 3/8"	1	
20	23037	HOUSING, PITCH CONTROL GEARBOX	1	
21	1529	GEAR, DRIVE PITCH CONTROL	1	
22	2649	COVER, PITCH CONTROL HOUSING RDRS	1	
23	9191	SCREW, BHSC M5-0.8X16MM, ZP	4	
24\$	0185	SCREW, SHS 3/8-16 X 3/8", NO PLATE	1	
25\$	1528	SCREW, SHS 1/4-20 X 5/16" H.D.P	2	
26#	1616	BOLT, SHOULDER .50 DIA. x .469 x 3/8-16	1	
27#	1733	WASHER, 1/2 X 1/32, AN960-816L	1	
28\$	1615	LEVER, TROWEL ADJ.	1	
29\$	1162 A	CAP, GREASE ZERK, #2 YELLOW	1	
30\$	2621	FITTING, GREASE ZERK STR 1/4-28	1	
31#	3231	SPACER, .75 DIA. x .406 DIA. x .688	1	
32#	4403	KNOB, ROUND 1-3/8 DIA. x 3/8-16 BLACK	1	
33	9027	YOKE ARM	1	
34	9028	PIN, YOKE	1	
35	10136	WASHER, FLAT SAE 3/8	2	
36	0683	PIN, COTTER 3/32D X 3/4"	2	
37	1617	LEVER, TROWEL ASSY.....	2	INCLUDESITEMSW/\$
38\$	2737	KIT, KNOB	1	INCLUDESITEMSW/#
39	4014	SCREW, 2-3/16 P-K TYPE U DRIVE	2	
40	23579	TOWER ASSY., PITCH CONTROL, LH	1	
41	23580	TOWER ASSY., PITCH CONTROL, RH	1	

PITCH CONTROL DRIVE CABLE ASSY.

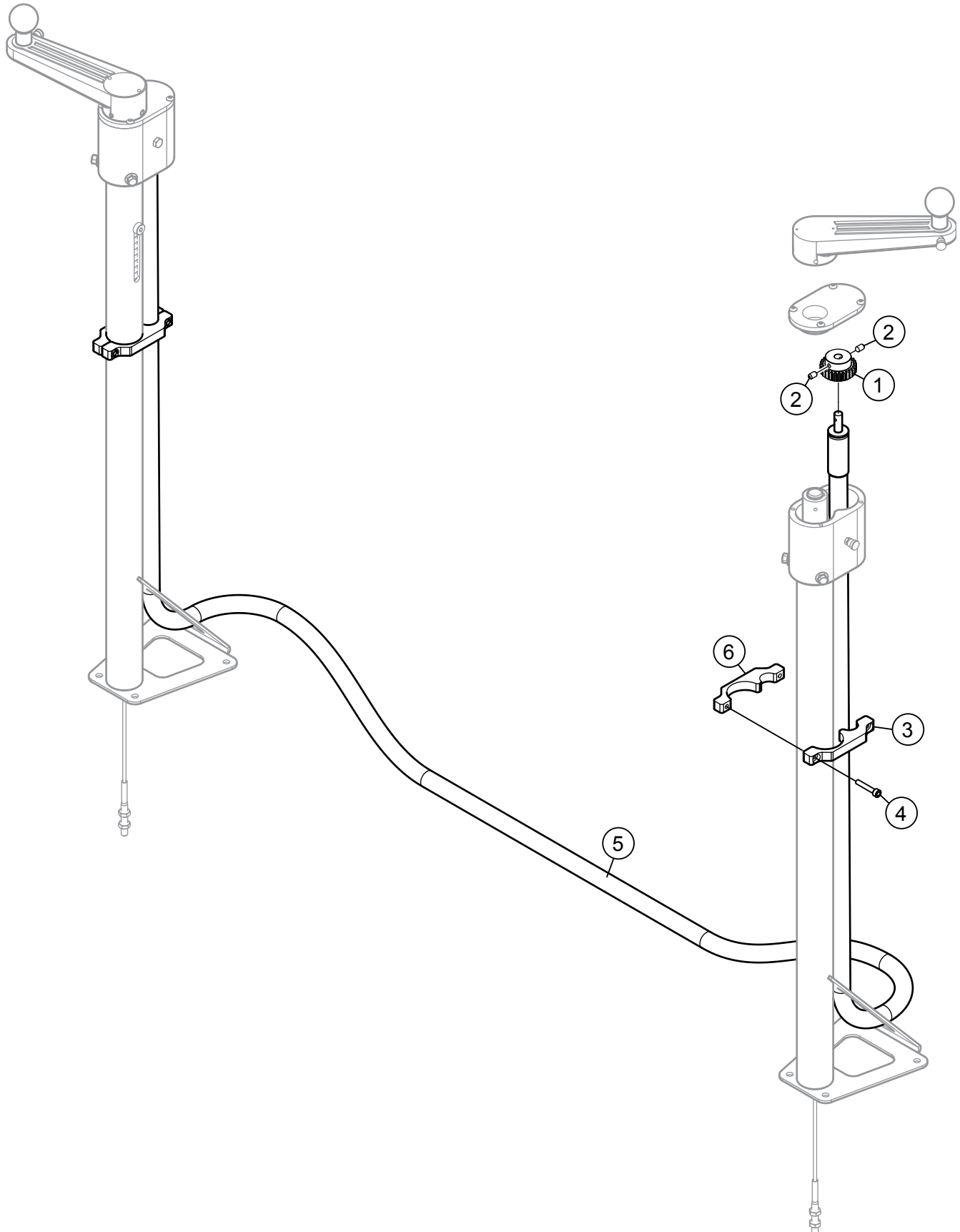

PITCH CONTROL DRIVE CABLE ASSY.

<u>NO.</u>	<u>PART NO.</u>	<u>PART NAME</u>	<u>QTY.</u>	<u>REMARKS</u>
1	23036	GEAR, PITCH CONTROL	1	
2	9195	SHS M5-0.8 X 10 CONE PT PATCH	2	
3	23295	CLAMP, PITCH CABLE	1	
4	37325	SHC M5-0.8 X 30MM	2	
5	23503	DRIVE CABLE, PITCH CONTROL	1	
6	23615	CLAMP, PITCH CABLE, THREADED	1	

NOTICE

Indicated quantities are for one pitch control drive assembly. If ordering for two pitch control drives, double the quantity.

DRIVE ASSY.

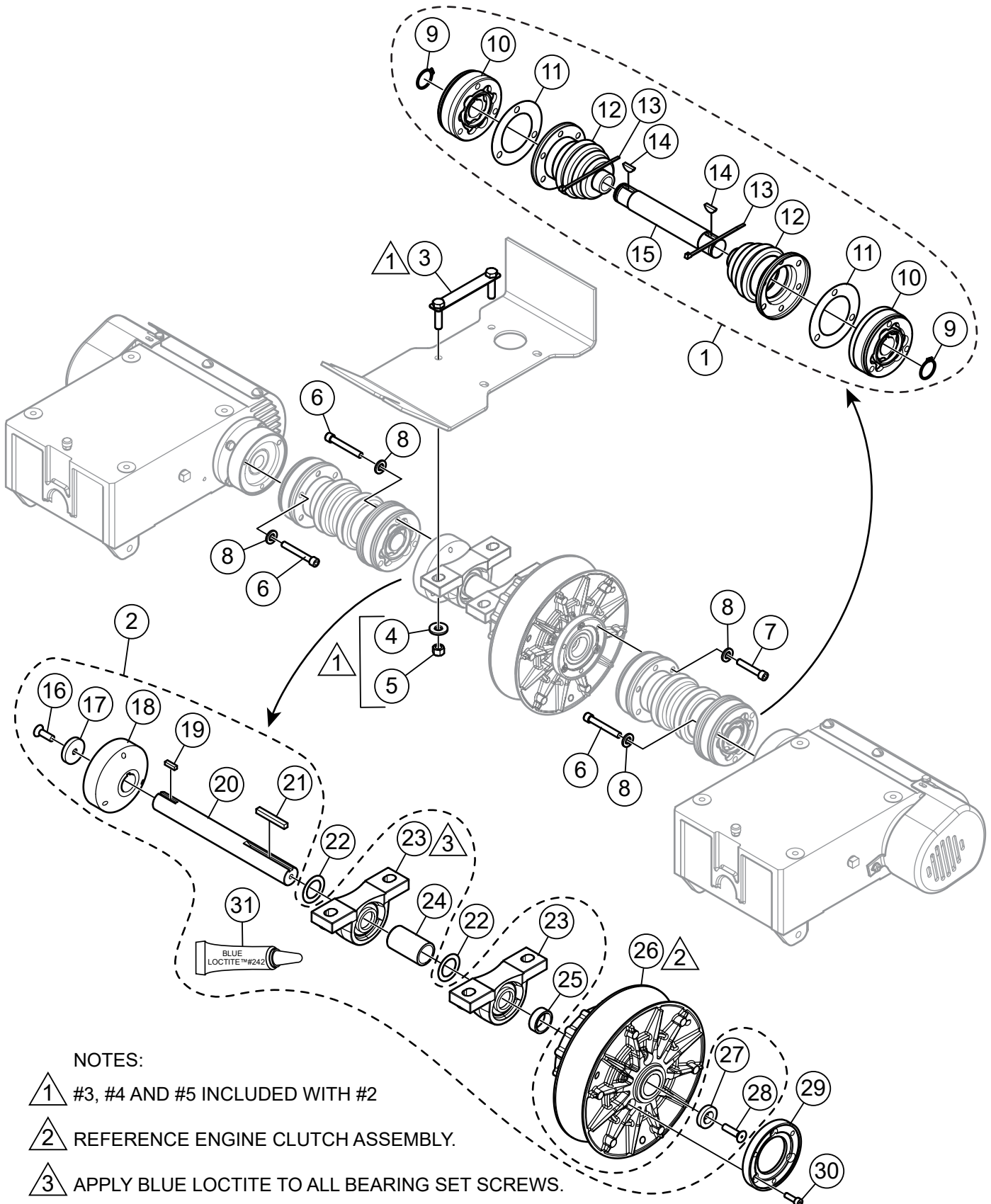

DRIVE ASSY.

<u>NO.</u>	<u>PART NO.</u>	<u>PART NAME</u>	<u>QTY.</u>	<u>REMARKS</u>
1	23477	CV JOINT ASSEMBLY.....	2	INCLUDES ITEMS W/@
2	23485-SK	CROSS SHAFT ASSEMBLY.....	1	INCLUDES ITEMS W/%
3%	20186	PLATE, PILLOW BLOCK BEARING MOUNT	2	
4%	13351	WASHER, FLAT 3/8 EXT THICK HIGH STRGTH	4	
5%	10133	NUT, NYLOC 3/8-16	4	
6	2186	SCREW, SHC 5/16-18 X 2-1/4" PLTD	9	
7	0243	SCREW, SHC 5/16-18 X 1-3/4"	3	
8	0161 C	WASHER, LOCK, 5/16 MED.	12	
9@	2090	SNAP RING, TRUARC#5100-106 1.062 DIAx.056	2	
10@	392052	JOINT, C.V.	2	
11@	11108	GASKET, C.V. JOINT BOOT	2	
12@	2259	BOOT ASM, C.V. JOINT	2	
13@	1662	TIE, CABLE TIE TY-RAP BLACK	2	
14@	0126	KEY, WOODRUFF #606 3/16x3/4 (#9)	2	
15@	2071	SHAFT, C.V. JOINT 7.44LG	1	
16%	1146	SCREW, FHSC 5/16-18 X 1", NYLOC, NP	1	
17%	2037	SPACER, CSK 1.375 DIA. x .328 DIA. x .250	1	
18%	2029	COUPLER, C.V. 1.000 DIA SHAFT DRIVE	1	
19%	10909	KEY, 3/16" SQ X 11/16"	1	
20%		SHAFT, DRIVE BEARING	1	MUST ORDER P/N 23485-SK
21%	6059 B	KEY, 1/4 SQ X 2"	1	
22	11773	SHIM, STEEL .031 x 1.500 DIA .x 1.000 DIA.	2	
23%	32484	BEARING, P-BLOCK 1.0"-JIB #VPLS205-16	2	
24%	23531	SPACER, BEARING SHAFT	1	
25%	23532	SPACER, LOWER CLUTCH	1	
26	23511	PULLEY, DRIVEN JWN24	1	
27%	23484	RETAINER, DRIVEN CLUTCH	1	
28%	9092	SCREW, FHSC 5/16-18 X .25" NYLON PATCH	1	
29	23480	COUPLER, CV JOINT	1	
30	17108	SCREW, SHC M6-1.00 X 20, DIN912 CL12.9	3	
31%	1477	LOCTITE 242 BLUE .5CC	1	

ENGINE CLUTCH ASSY.

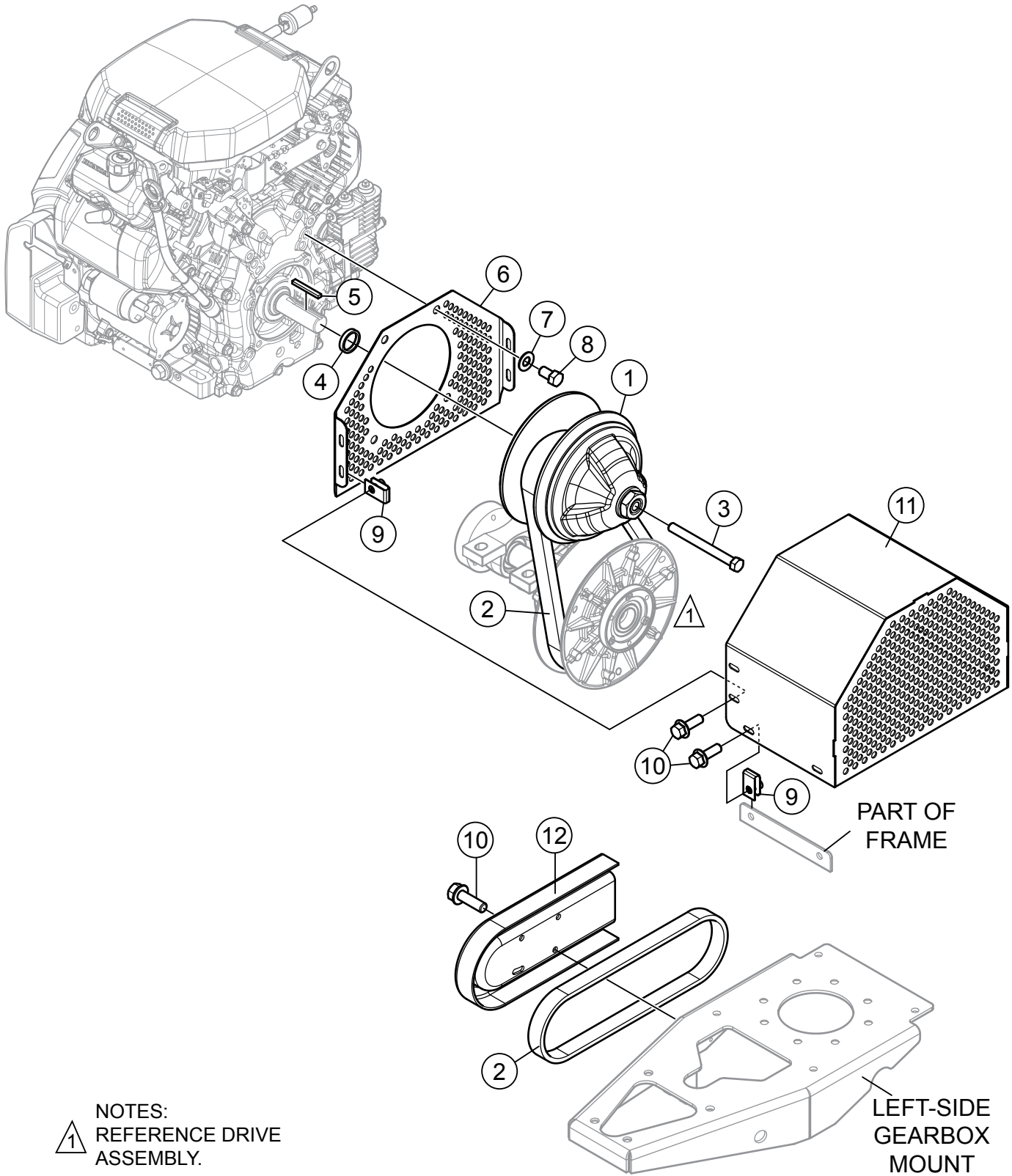

ENGINE CLUTCH ASSY.

<u>NO.</u>	<u>PART NO.</u>	<u>PART NAME</u>	<u>QTY.</u>	<u>REMARKS</u>
1	23512	CLUTCH, DRIVE	1	
2	23513	BELT, LIGHT DUTY RIDER CVT	2	
3	23516	SCREW, HHC 7/16-20 x 4.0" GRD 8	1	
4	23590	SPACER, UPPER CLUTCH	1	
5	22632	KEY, STEEL .188 x .250 x 2.063	1	
6	23565	PANEL, BACK, BELT GUARD	1	
7	933243	WASHER, FLAT SAE 7/16 GRD 9 YZ	4	
8	15563	SCREW, HHC 7/16-14 X 0.75"	4	
9	11534	NUT, "U" TYPE, 1/4-20	8	
10	49048	SCREW, HHFS 1/4-20 X 3/4" GR5	10	
11	23562	GUARD, BELT	1	
12	2429	BELT HOLDER, CVT SPARE BELT	1	

SPIDER ASSY. (LEFT)

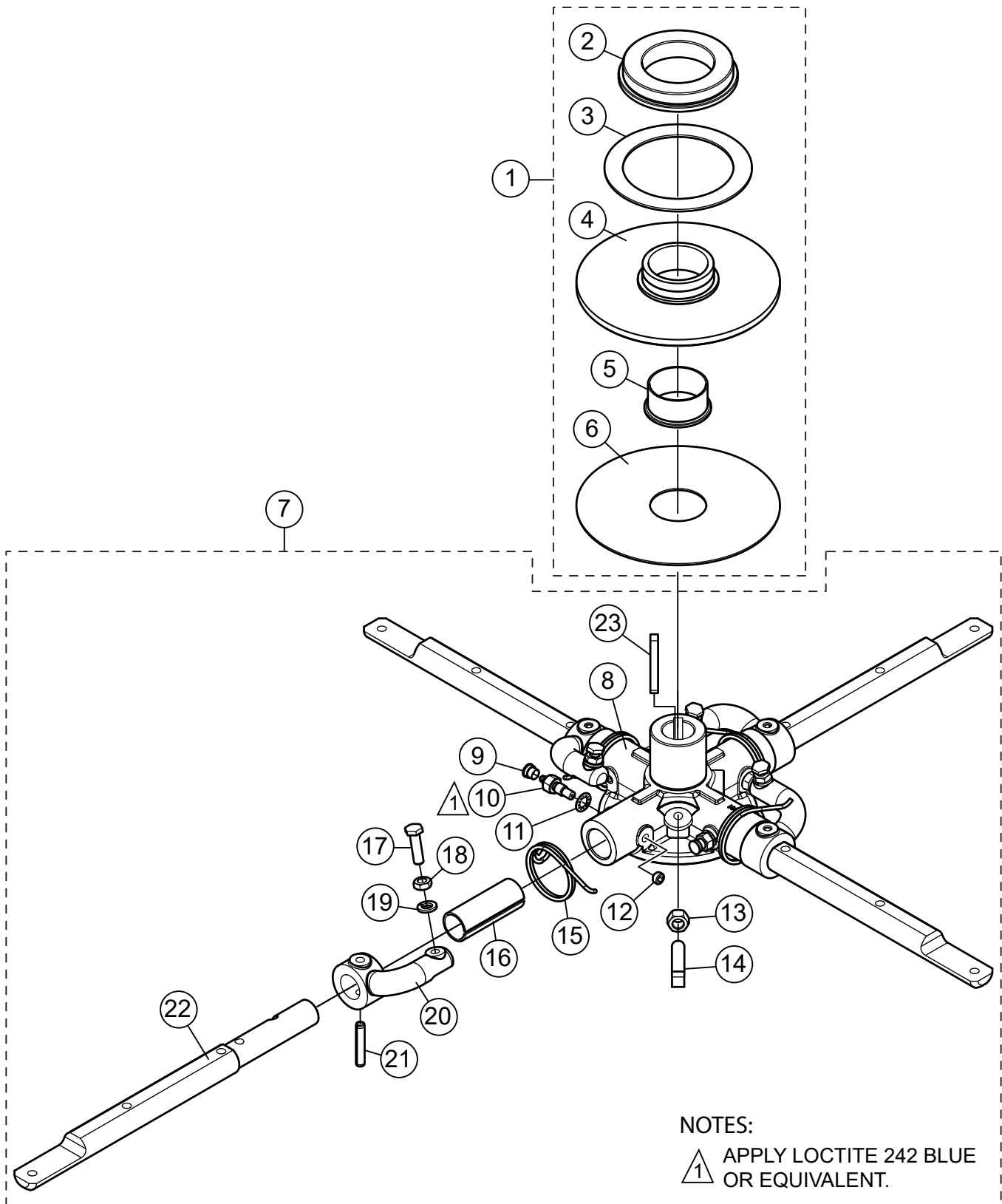

SPIDER ASSY. (LEFT)

<u>NO.</u>	<u>PART NO.</u>	<u>PART NAME</u>	<u>QTY.</u>	<u>REMARKS</u>
1	10968	THRUST COLLAR ASSY., JB SEALED.....	1.....	INCLUDES ITEMS W/@
2@	12778	BEARING, THRUST 6013-2RS	1	
3@	12208	WEAR RING, SEALED THRUST	1	
4@	10793	THRUST COLLAR ASSY.	1	
5@	1471	BUSHING, BRONZE	1	
6@	1154 A	PLATE, WEAR	1	
7	20369	SPIDER ASSEMBLY, 4BLD LEFT SIDE	1.....	INCLUDES ITEMS W/%
8%	12478	SPIDER HUB ASSEMBLY	1	
9%	1162 A	CAP, GREASE ZERK, #2 YELLOW	4	
10%	A5978	SCREW, ARM RETAINING	4	
11%	1875	WASHER, INT. SHKP, 3/8	4	
12%	11602	SCREW, SHS 3/8-16 X .25"	4	
13%	1456	NUT, HEX FINISH 3/8-16	1	
14%	12097	SCREW, SQHS 3/8-16 X 1-3/4" CONE GRD 8	1	
15%	1316	SPRING, LS J/B ARM RETURN	4	
16%	1157 A	BUSHING, INSERT	4	
17%	0164 B	SCREW, HHC ROUNDED	4	
18%	1876	NUT, HEX JAM 3/8-16 CLASS 2B	4	
19%	0166 A	WASHER, LOCK, 3/8 MED.	4	
20%	1163-1	LEVER, TROWEL ARM, RIGHT HAND	4	
21%	4164	PIN, ROLL 5/16 X 1-3/4", NO PLATE	4	
22%	20409	ARM, TROWEL BLADE JWN LEFT	4	
23%	9193	KEY, SQ RN .312 X 3.00	1	

SPIDER ASSY. (RIGHT)

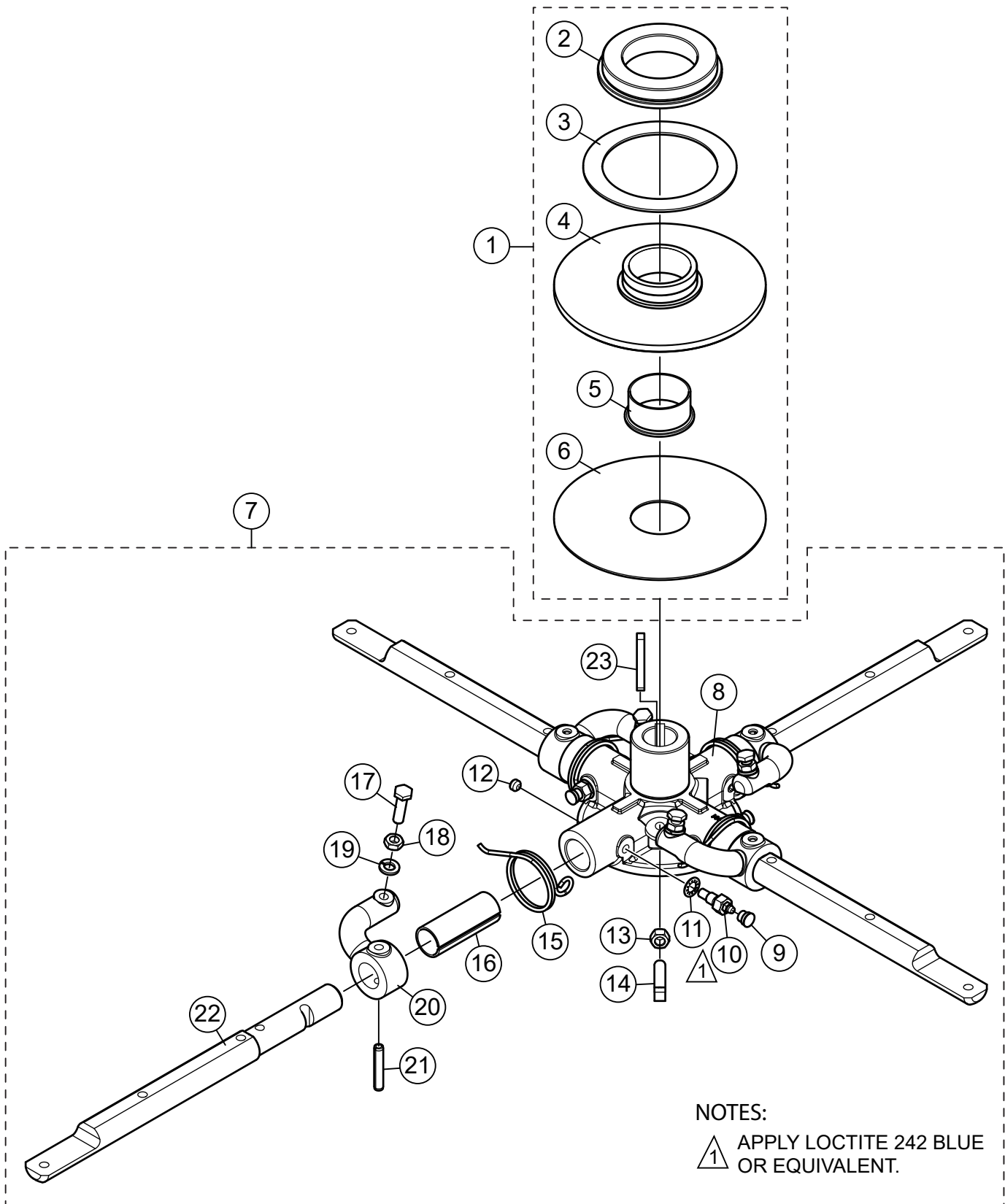

SPIDER ASSY. (RIGHT)

<u>NO.</u>	<u>PART NO.</u>	<u>PART NAME</u>	<u>QTY.</u>	<u>REMARKS</u>
1	10968	THRUST COLLAR ASSEMBLY, JB SEALED	1	INCLUDES ITEMS W/@
2@	12778	BEARING, THRUST 6013-2RS	1	
3@	12208	WEAR RING, SEALED THRUST	1	
4@	10793	THRUST COLLAR ASSY.	1	
5@	1471	BUSHING, BRONZE	1	
6@	1154 A	PLATE, WEAR	1	
7	20370	SPIDER ASSEMBLY, 4BLD RIGHT SIDE	1	INCLUDES ITEMS W/%
8%	12478	SPIDER HUB ASSEMBLY	1	
9%	1162 A	CAP, GREASE ZERK, #2 YELLOW	4	
10%	A5978	SCREW, ARM RETAINING	4	
11%	1875	WASHER, INT. SHKP, 3/8	4	
12%	11602	SCREW, SHS 3/8-16 X .25"	4	
13%	1456	NUT, HEX FINISH 3/8-16	1	
14%	12097	SCREW, SQHS 3/8-16 x 1-3/4" CONE GRD 8	1	
15%	1317	SPRING, RS J/B ARM RETURN	4	
16%	1157 A	BUSHING, INSERT	4	
17%	0164 B	SCREW, HHC ROUNDED	4	
18%	1876	NUT, HEX JAM 3/8-16 CLASS 2B	4	
19%	0166 A	WASHER, LOCK, 3/8 MED.	4	
20%	1555-1	LEVER, TROWEL ARM, LEFT HAND	4	
21%	4164	PIN, ROLL 5/16 X 1-3/4",NO PLATE	4	
22%	20408	ARM, TROWEL BLADE JWN RIGHT	4	
23%	9193	KEY, SQ RN .312x3.00	1	

FOOT PEDAL/THROTTLE ASSY.

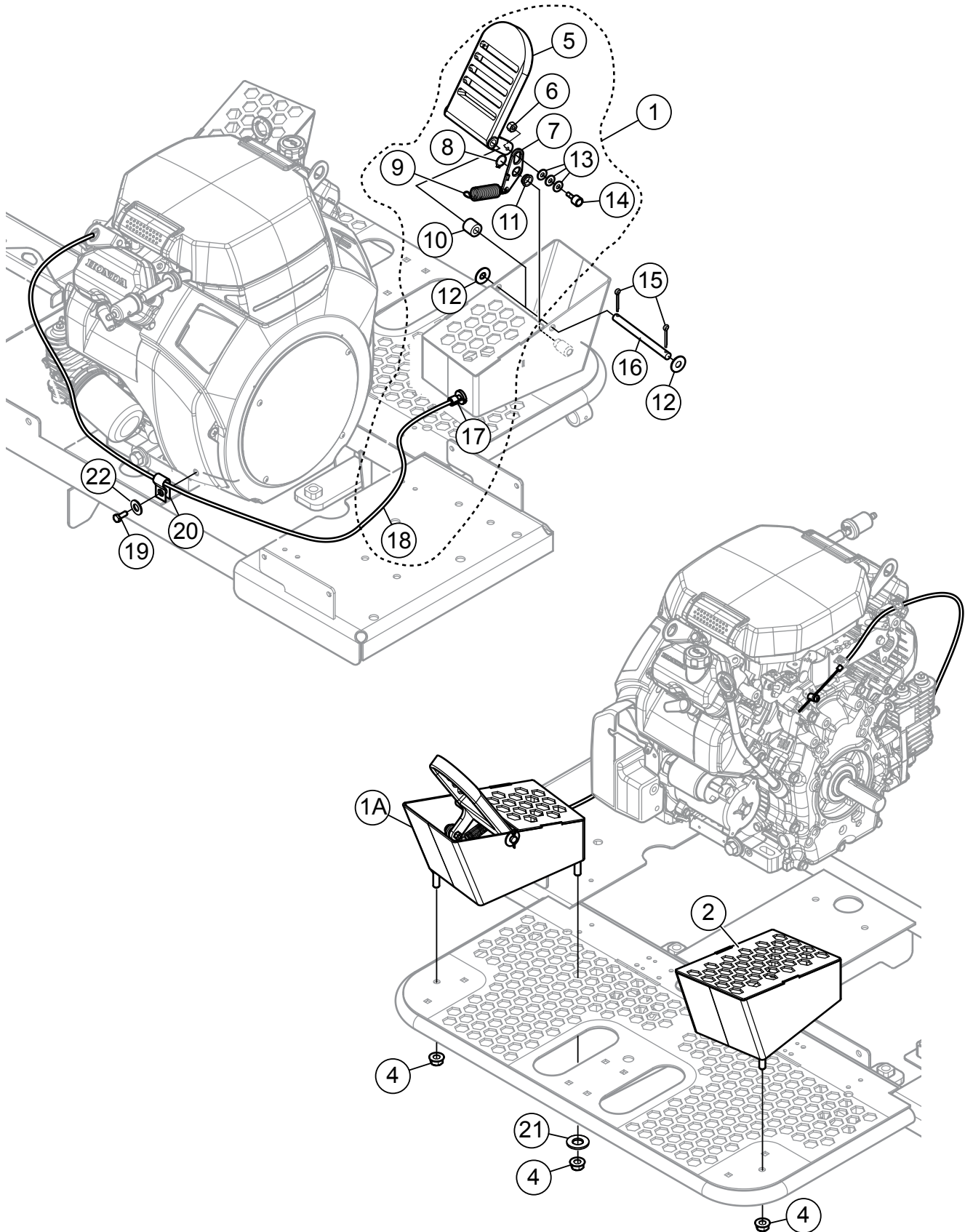

FOOT PEDAL/THROTTLE ASSY.

<u>NO.</u>	<u>PART NO.</u>	<u>PART NAME</u>	<u>QTY.</u>	<u>REMARKS</u>
1	23469	ACCELERATOR PEDAL ASSEMBLY	1.....	INCLUDES ITEMS W/@
1A@	23592	FOOT RISER, ACCELERATOR SIDE	1	
2	23568	FOOT RISER	1	
4	49071	NUT, FLANGED 5/16-18 SERRATED PLTD	4	
5@	23591	PEDAL, ACCELERATOR	1	
6@	10019	NUT, NYLOC 10-32	1	
7@	23473	LINKAGE, ACCELERATOR PEDAL	1	
8@	1737	RING, SNAP, TRUARC 5100-50	1	
9@	37527	SPRING, EXT. .625OD X 2.5L X .053 M WIRE	1	
10@	23596	SPACER, PEDAL	1	
11@	38368	BUSHING, SPLIT FLANGED, .5 ID	1	
12@	10136	WASHER, FLAT SAE 3/8	2	
13@	2203	WASHER, FLAT, #10	3	
14@	460018	CAM ROLLER, SAW FNR CONTROL	1	
15@	6014 B	PIN, COTTER 3/32D X 1.00"	2	
16@	2772	PIN, ACCELERATOR PEDAL	1	
17@	21824	ADJUSTER W/ THUMB WHEEL	1	
18@	23518	CABLE, THROTTLE JWN	1	
19	12464	SCREW, HHC M6-1.0 X 16MM	1	
20	8126	CLAMP, HOSE SUPPORT 1/2" SMALL	1	
21	933213	WASHER, FENDER, 5/16 X 1" ZINC	4	

CONTROL PANEL ASSY.

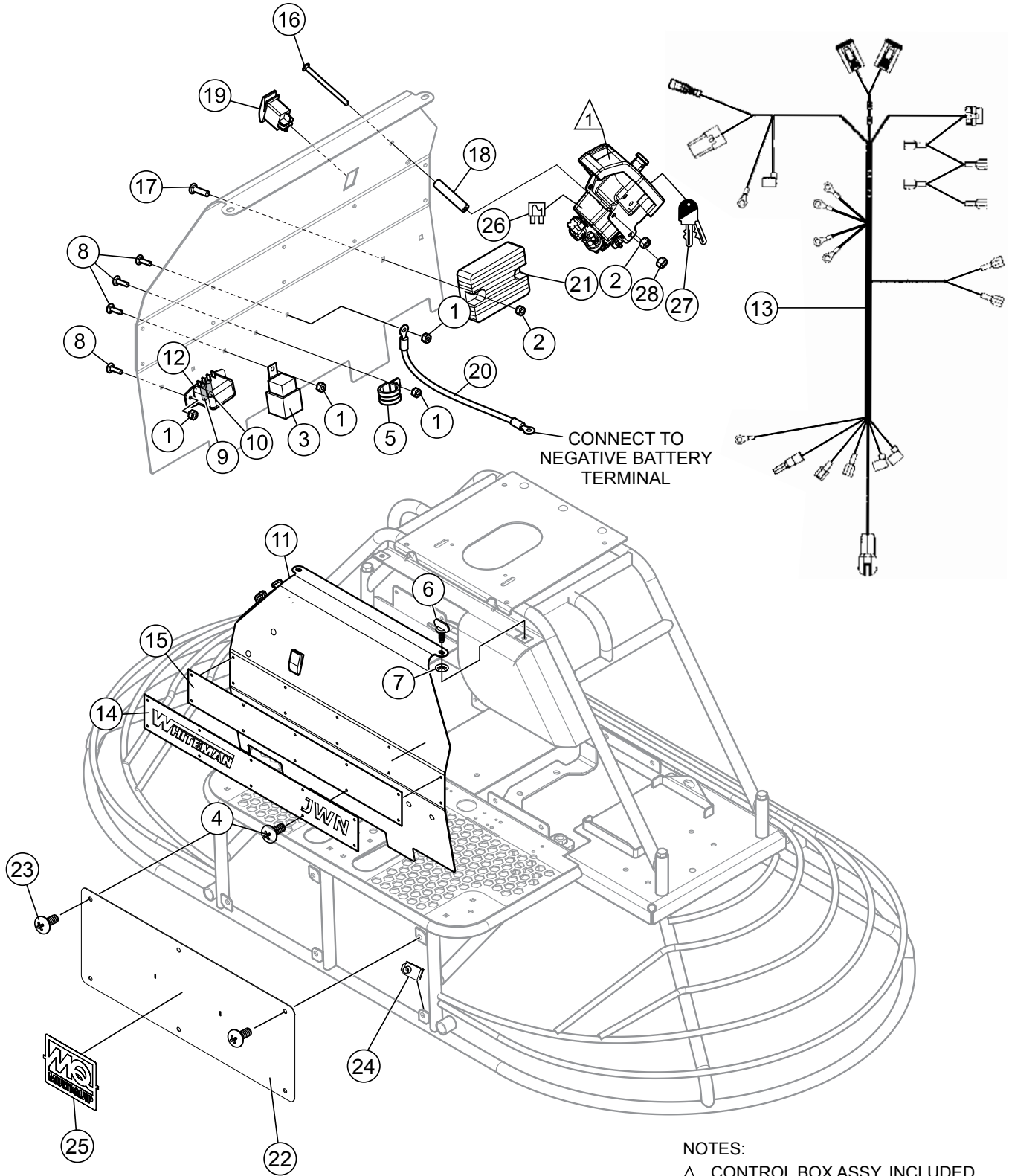

CONTROL PANEL ASSY.

<u>NO.</u>	<u>PART NO.</u>	<u>PART NAME</u>	<u>QTY.</u>	<u>REMARKS</u>
1	10019	NUT, NYLOC 10-32	7	
2	10024	NUT, NYLOC 1/4-20	2	
3	12017	RELAY, KILL	1	
4	19847	RIVET, POP, ALUM, 3/16x1/8-1/4 GRIP	10	
5	21574	CLAMP, LOOP CUSHIONED #16 0.25 HOLE	1	
6	21893	SCREW, FAST LEAD	2	
7	21986	WASHER, FAST LEAD-STAINLESS	2	
8	22131	BOLT, CARRIAGE 10-32 X 3/4 ZINC	5	
9	23284-030	FUSE, 3 AMP	1	
10	23284-150	FUSE, 15 AMP	1	
11	23526	PANEL, FRONT, JWN	1	
12	23534	FUSE BLOCK, 4 FUSE	1	
13	23540	HARNES,MAIN PANEL, JWN	1	
14	23549	PANEL, "WHITEMAN", JWN	1	
15	23577	PLATE, TRIM BACKING, JWN	1	
16	23595	BOLT, CARRIAGE 1/4-20 X 3-1/2"	2	
17	23620	BOLT, CARRIAGE 1/4-20 x 1"	2	
18	23622	SPACER, ENG CONTOL PANEL	2	
19	406000	SWITCH, ROCKER, CH# M-58031-01	1	
20	23605	WIRE, CONTROL PANEL GROUND	1	
21	31750Z2E803	REGULATOR 20 AMP, RECTIFIER ASSY.	1	
22	23612	PLATE, FRONT PANEL (LOWER)	1	
23	12287	SCREW, THP 1/4-20 X 3/4 SS	6	
24	11534	NUT, "U" TYPE"	6	
25	23235	BADGE, FOOT PLATFORM	1	
26	982004300	FUSE, 30A	1	
27	35110ZV5V501	KEY, IGNITION	2.....	REPLACES P/N 35110ZV5V50

LIGHTS ASSY.

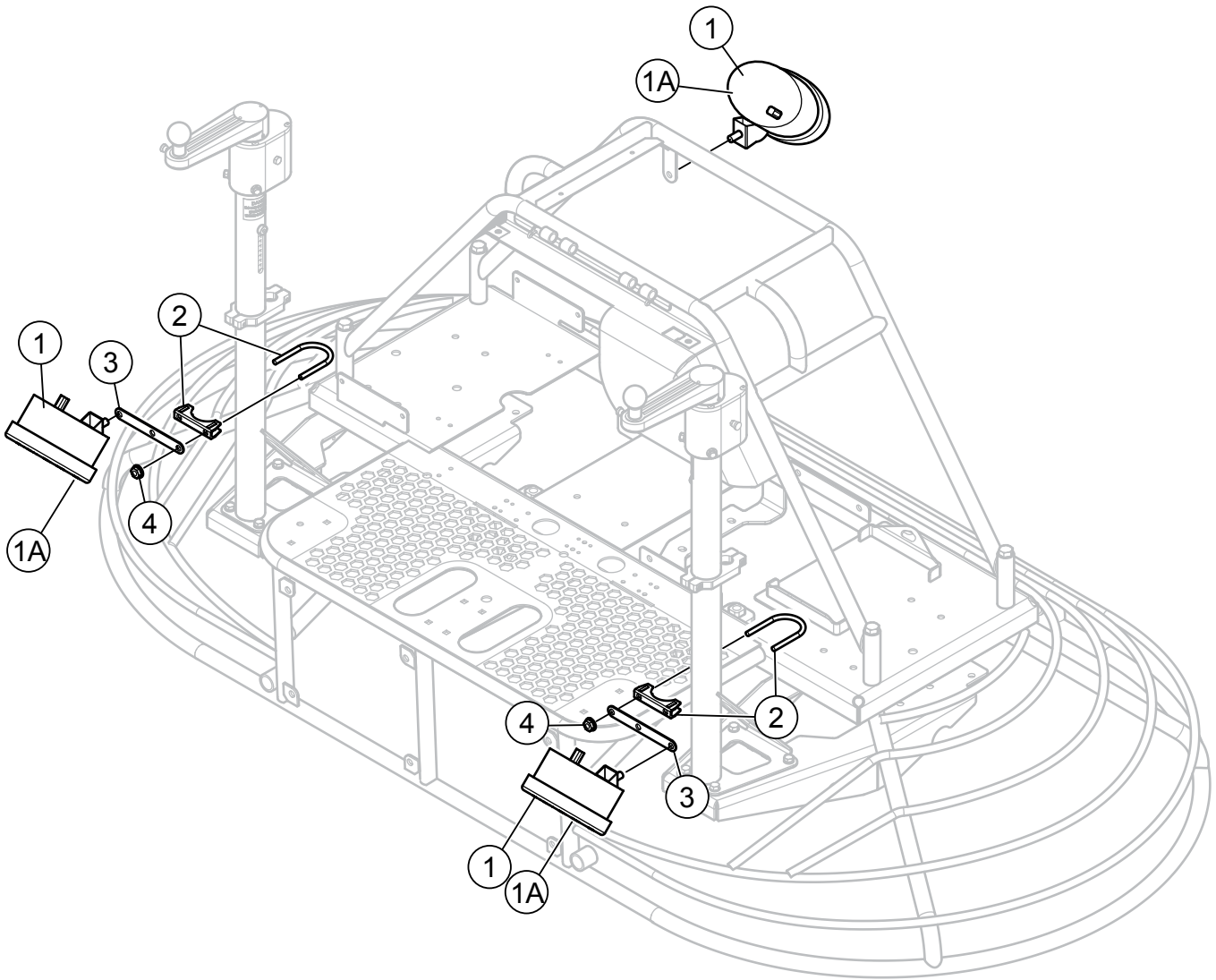

LIGHTS ASSY.

<u>NO.</u>	<u>PART NO.</u>	<u>PART NAME</u>	<u>QTY.</u>	<u>REMARKS</u>
1	22347	LIGHT, HELLA BOTTOM MOUNT OVAL	3	
1A	32640	LIGHT, LED 20W, OVAL	3	
2	2534	CLAMP, 1-3/4" MUFFLER.....	2.....	INCLUDES ITEMS W/@
3	2531	BRACKET, LIGHT SIDE	2	
4@		NUT	4	

FUEL ASSY.

<u>NO.</u>	<u>PART NO.</u>	<u>PART NAME</u>	<u>QTY.</u>	<u>REMARKS</u>
1	12277	CLAMP, HOSE WORM, #36, 1 13/16 - 2 3/4	2	
2	12287	SCREW, THP 1/4-20 X 3/4" SS	3	
3	16185	FITTING, PLUG 1/4MP SQ HD	1	
4	21597	BUMPER,STEM 1.0"D x .5S x .31	2	
5	22067	CLAMP, STEPLESS EAR 1/4" HOSE #138	2	
6	22081	SHUTOFF VALVE, 1/4 NPT, 1/4 HOSE	1	
7	23297	MANUAL HOLDER, PICTOGRAPH SAE J232	1	
8	23505	CANISTER, CARBON, 390CC/EPA	1	
9	23507	GROMMET, ROLL OVER VALVE/EPA	2	
10	12007	FITTING, 90° 4SBARB X 6-4SBARB THRU TANK	1	
11	23514	CAP, RATCHET W/GAUGE "GASOLINE" (10.5")/EPA	1	
12	23556	FUEL TANK, ASSEMBLY	1	
13	23557	PLUG, FUEL TANK VENT	1	
14	23593	BRACKET, CHARCOAL CANISTER	1	
15	23619	SCREW, HHFS 1/4-20 X 1-1/4", ZP	4	
16	49070	NUT, FLANGED 1/4-20 SERRATED PLTD	3	
17	60004	HOSE,FUEL .187 D 50PSI LOW PERM CARB2006/EPA	1.0 FT	
18	60013	HOSE,FUEL .250 D 50PSI LOW PERM CARB2006/EPA	2.0 FT	
19	60028	HOSE,FUEL .312 D 50PSI LOW PERM CARB2006/EPA	2.0 FT	
20	911329	FITTING, PLUG 3/8MP MAGNET	1	

BATTERY ASSY.

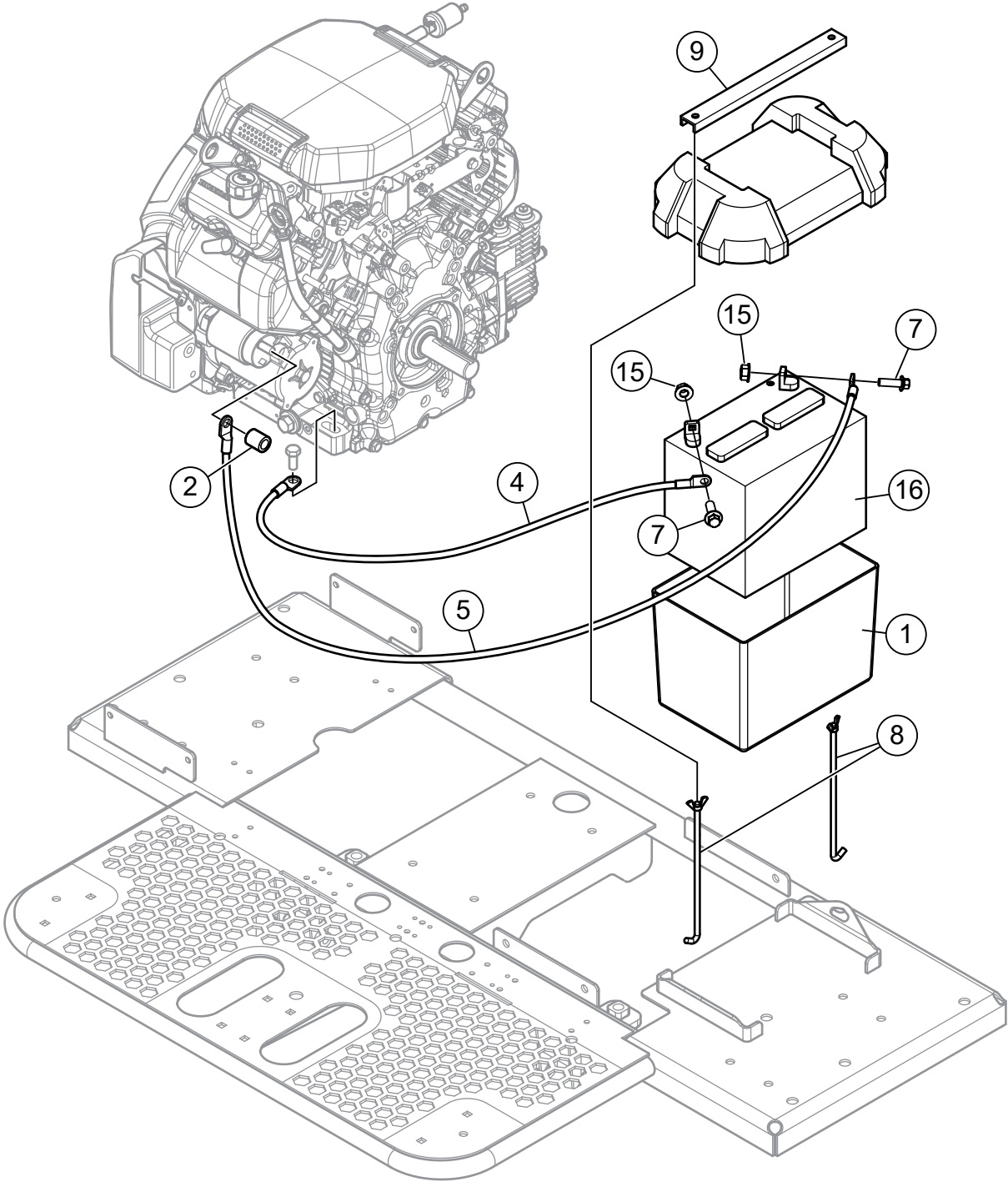

BATTERY ASSY.

<u>NO.</u>	<u>PART NO.</u>	<u>PART NAME</u>	<u>QTY.</u>	<u>REMARKS</u>
1	2449	BATTERY BOX, GR. U1	1	
2	2762	BOOT,TERMINAL	1	
4	12022	CABLE, BATTERY NEG 4GA X 23	1	
5	12675	CABLE, BATTERY POS 4GA X 36"	1	
7	42542	SCREW, HFS M6-1.0 X16	2	
8	20194	KIT, BATTERY HOLD DOWN HARDWARE	1	
9	20356	BRKT, BATTERY HOLD-DOWN	1	
15	42352	NUT, HEX, SERRATED-FLANGE, M6 -1 .0	2	
16	4671	BATTERY, 12V GROUP U1 WET CELL	1	

ENGINE AND MUFFLER ASSY.

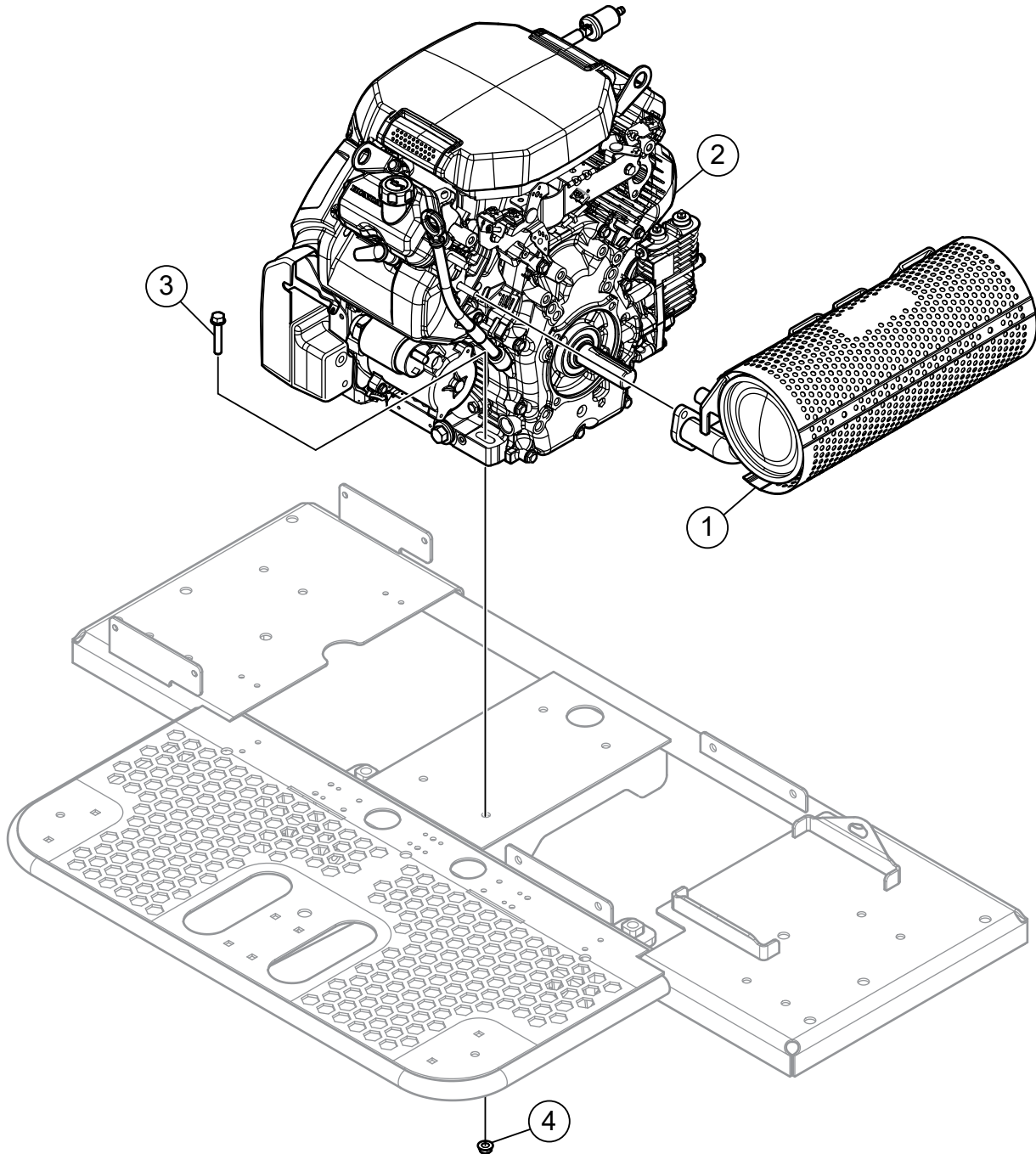

ENGINE AND MUFFLER ASSY.

<u>NO.</u>	<u>PART NO.</u>	<u>PART NAME</u>	<u>QTY.</u>	<u>REMARKS</u>
1	22610	MUFFLER, RIGHT DISCHARGE, HONDA	1	
2	22609	ENGINE, HONDA GX690RTAF-R280, 24HP	1	
3	22174	SCREW, HHFS 5/16-18 x 1.75" GR5	4	
4	49071	NUT, FLANGED 5/16-18 SERRATED PLTD	4	

SPRAY ASSY. (S/N NF0210282 AND BELOW)

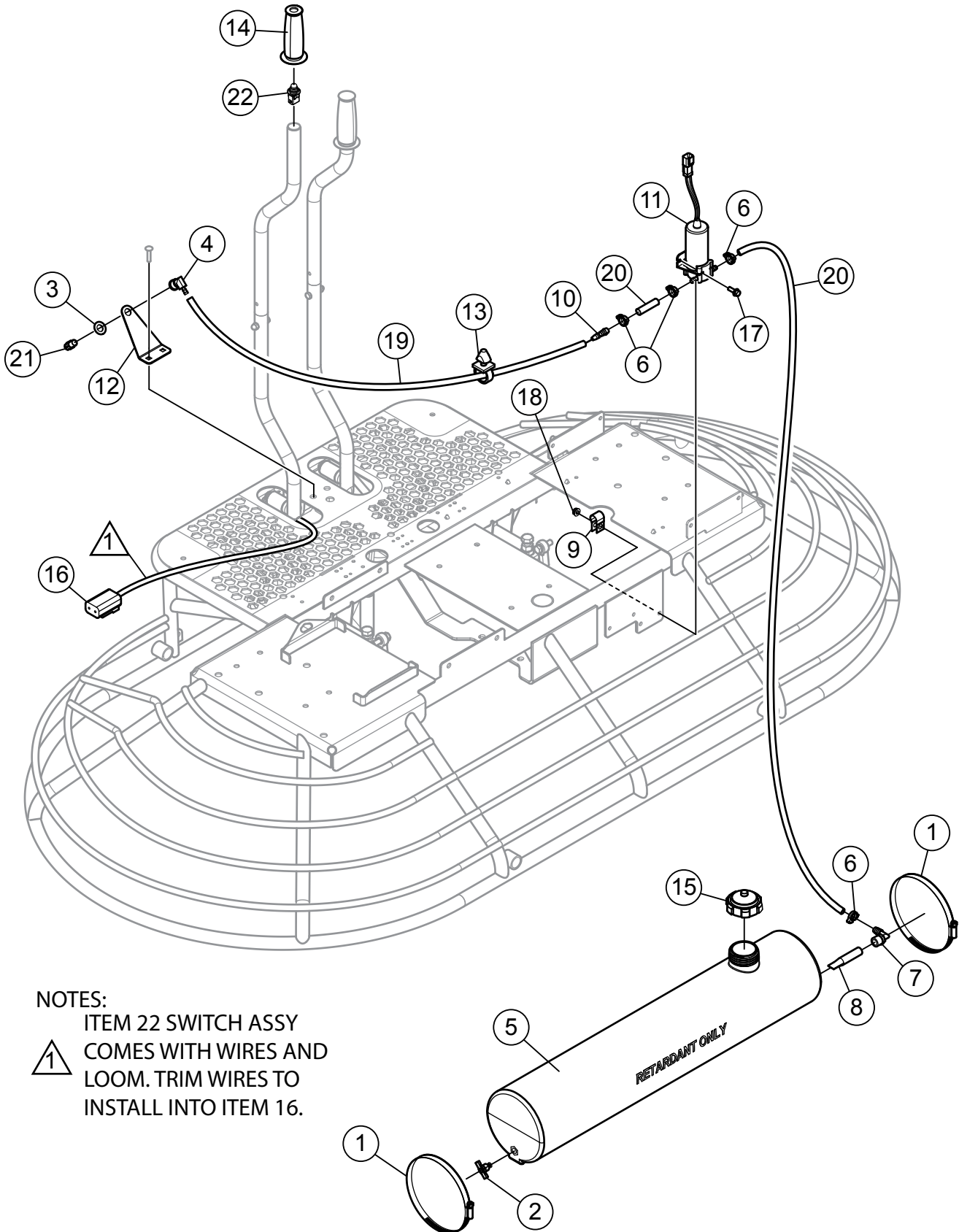

NOTES:

ITEM 22 SWITCH ASSY
COMES WITH WIRES AND
LOOM. TRIM WIRES TO
INSTALL INTO ITEM 16.



SPRAY ASSY. (S/N NF0210282 AND BELOW)

<u>NO.</u>	<u>PART NO.</u>	<u>PART NAME</u>	<u>QTY.</u>	<u>REMARKS</u>
1	2398	CLAMP, HOSE WORM #96 4.75" TO 6.50"	2	
2	2478	FITTING, PETCOCK RAD DRAIN 1/4MP	1	
3	2898	WASHER, BONDED NEOPRENE 1" X 1/2"	1	
4	2912	FITTING, BRASS 90 4BARB-1/4FP	1	
5	2916	WATER TANK	1	
6	2918	CLAMP, HOSE- PLASTIC .475 - .536	4	
7	2925	FITTING, PLASTIC 90 6BARB 3/8 MP	1	
8	2926	SCREEN, STRAINER	1	
9	8125	CLAMP,HOSE 5/8"	1	
10	10022	FITTING, PLASTIC 6 BARB-4 BARB	1	
11	23434	PUMP, SPRAY W\CONNECTOR	1	
12	23576	MOUNTING BRACKET, SPRAY NOZZLE	1	
13	23610	CLIP, PUSH IN, .375 ID	6	
14	23611	GRIP, HANDLE W\ 5/8" HOLE	1	W/SPRAY OPTION ONLY
15	2108	CAP, SPRAY TANK	1	
16	37403	CONNECTOR KIT, DEUTSCH DT06-2S	1	
17	49048	SCREW, HHFS 1/4-20 x 3/4" GR5	2	
18	49070	NUT, FLANGED 1/4-20 SERRATED PLTD	2	
19	60001	HOSE, PVC CLEAR .250 DIA. x .375 DIA., 4.5'.....	5	1PC=1FT
20	60002	HOSE, PVC CLEAR .375 DIA. x .50 DIA., 1'.....	1	1PC=1FT
21	392292	NOZZLE, SPRAY	1	
22	11430	SWITCH ASSY. W\WIRES AND LOOM	1	

SPRAY ASSY. (S/N NH0210361 AND ABOVE)

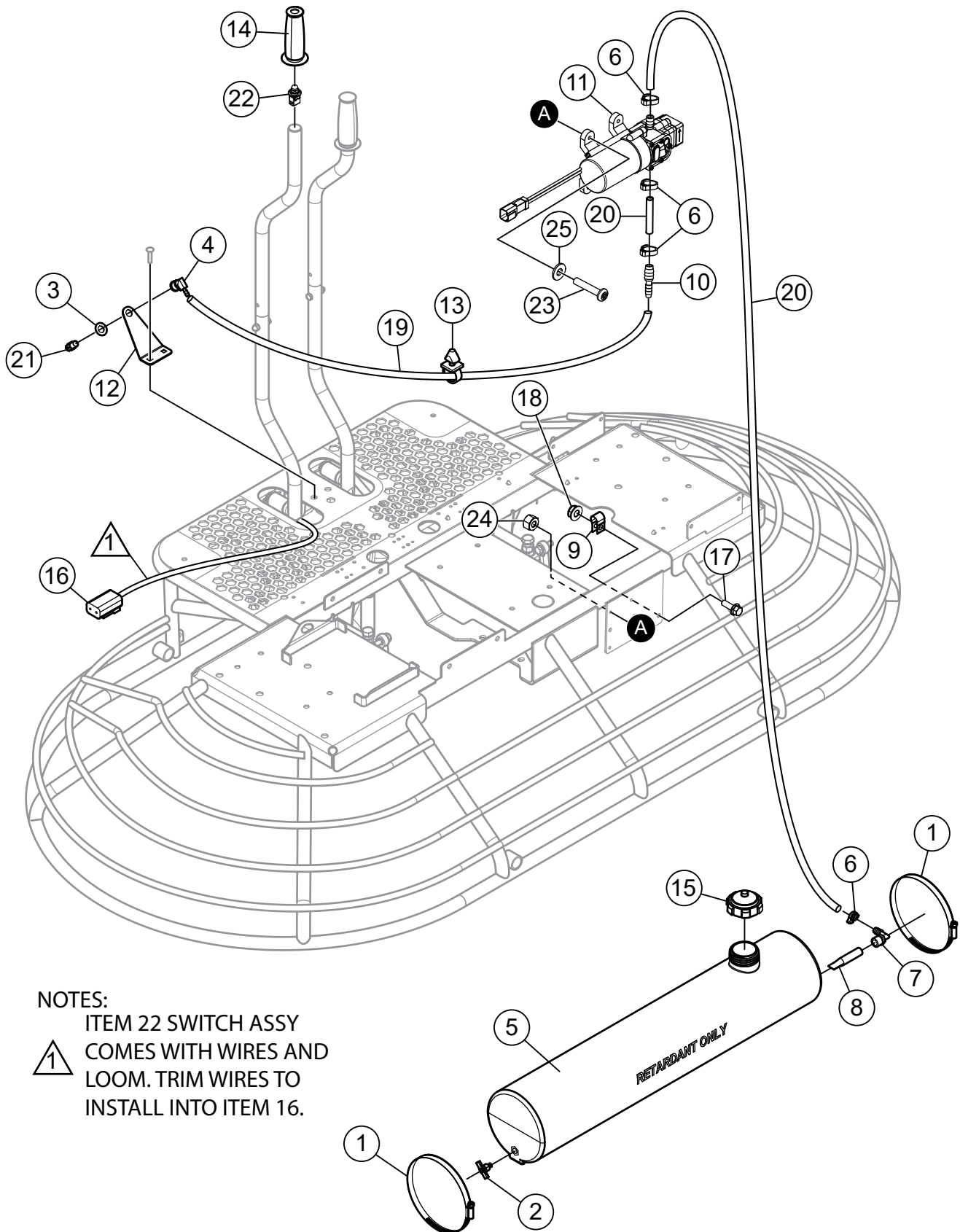

NOTES:

 ITEM 22 SWITCH ASSY
 COMES WITH WIRES AND
 LOOM. TRIM WIRES TO
 INSTALL INTO ITEM 16.

SPRAY ASSY. (S/N NH0210361 AND ABOVE)

<u>NO.</u>	<u>PART NO.</u>	<u>PART NAME</u>	<u>QTY.</u>	<u>REMARKS</u>
1	2398	CLAMP, HOSE WORM #96 4.75" TO 6.50"	2	
2	2478	FITTING, PETCOCK RAD DRAIN 1/4MP	1	
3	2898	WASHER, BONDED NEOPRENE 1" X 1/2"	1	
4	2912	FITTING, BRASS 90 4BARB-1/4FP	1	
5	2916	WATER TANK	1	
6	2918	CLAMP, HOSE- PLASTIC .475 - .536	4	
7	2925	FITTING, PLASTIC 90 6BARB 3/8 MP	1	
8	2926	SCREEN, STRAINER	1	
9	8125	CLAMP, HOSE 5/8"	1	
10	10022	FITTING, PLASTIC 6 BARB-4 BARB	1	
11	30560	PUMP, SPRAY W/CONNECTOR	1	
12	23576	MOUNTING BRACKET, SPRAY NOZZLE	1	
13	23610	CLIP, PUSH IN, .375 ID	6	
14	23611	GRIP, HANDLE W/ 5/8" HOLE	1 W/SPRAY OPTION ONLY
15	2108	CAP, SPRAY TANK	1	
16	37403	CONNECTOR KIT, DEUTSCH DT06-2S	1	
17	49048	SCREW, HHFS 1/4-20 x 3/4" GR5	1	
18	49070	NUT, FLANGED 1/4-20 SERRATED PLTD	1	
19	60001	HOSE, PVC CLEAR .250 DIA. x .375 DIA., 4.5'.....	5 1PC=1FT
20	60002	HOSE, PVC CLEAR .375 DIA. x .50 DIA., 1'.....	1 1PC=1FT
21	392292	NOZZLE, SPRAY	1	
22	30568	SWITCH ASSY. W/WIRES AND LOOM	1	
23	15177	SCREW, PHP 10-32 x 1"	4	
24	10019	NUT, NYLOC 10-32	4	
25	2203	WASHER, FLAT, #10	4	

HARNESS ASSY.

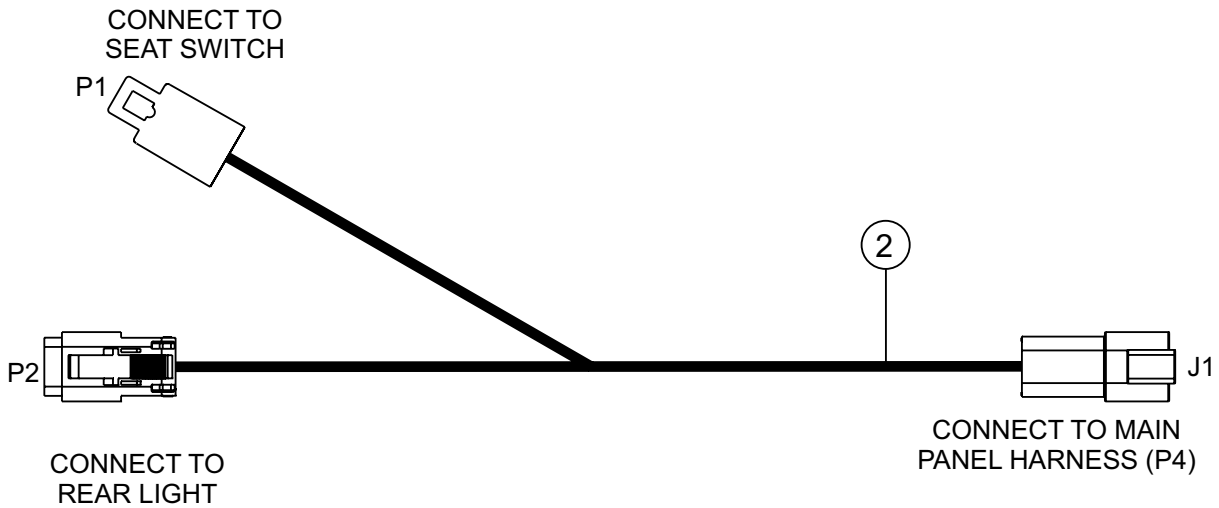
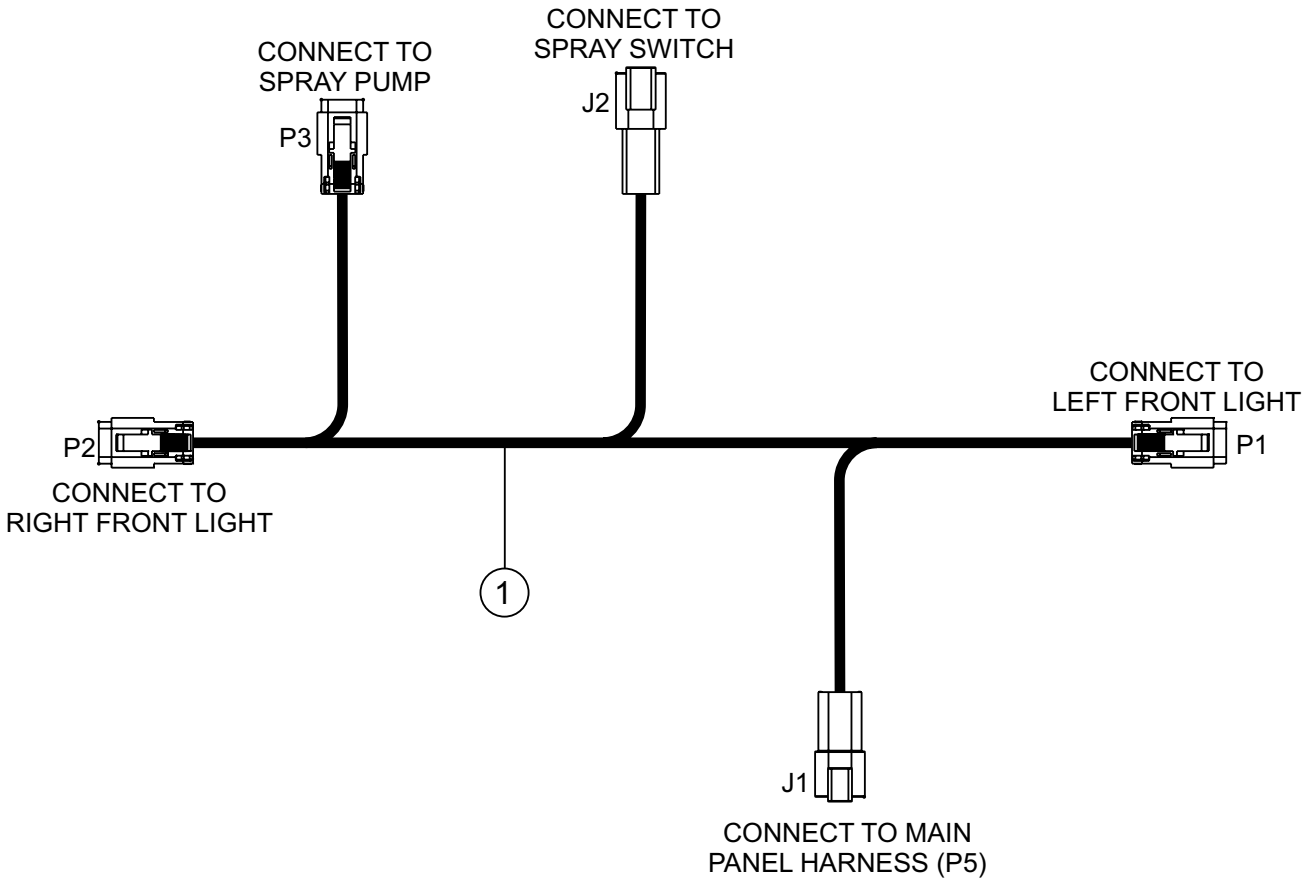

HARNESS ASSY.

<u>NO.</u>	<u>PART NO.</u>	<u>PART NAME</u>	<u>QTY.</u>	<u>REMARKS</u>
1	23542	HARNESS, MAIN FRAME	1	
2	23541	HARNESS, SEAT FRAME	1	

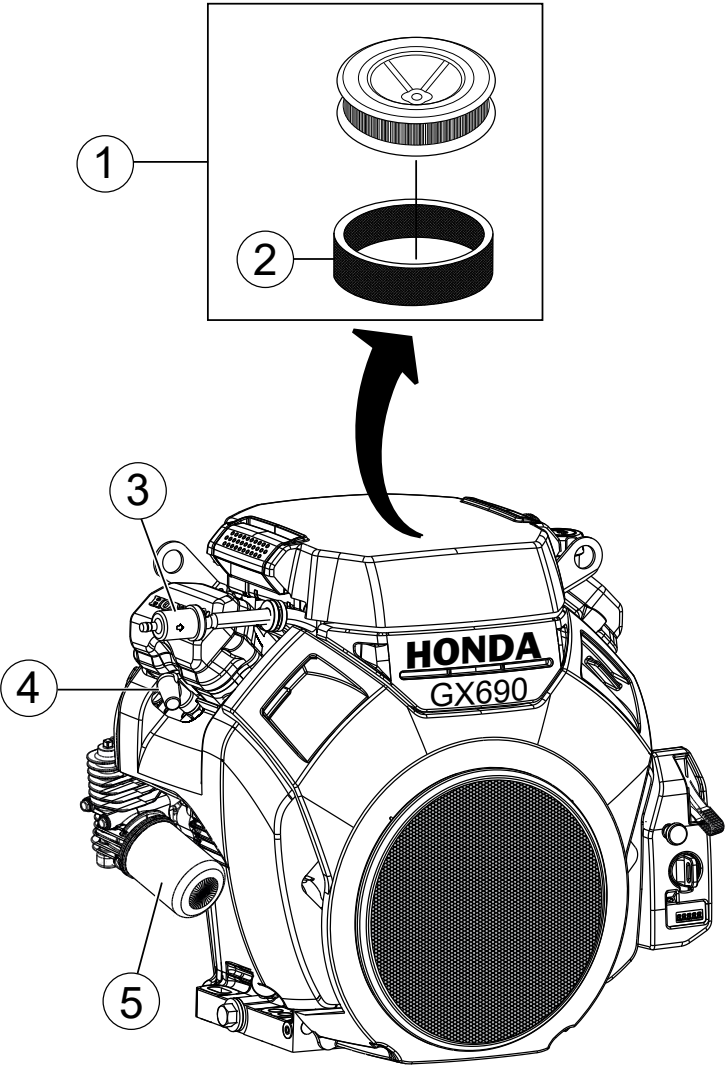

ENGINE SERVICE PARTS

<u>NO.</u>	<u>PART NO.</u>	<u>PART NAME</u>	<u>QTY.</u>	<u>REMARKS</u>
1	17210Z6L010	ELEMENT COMP. AIR CLEANER.....	1.....	INCLUDES ITEMS W/\$
2\$	17218Z6L000	FILTER, OUTER AIR CLEANER	1	
3	16910Z6L003	FILTER, INLINE FUEL	1	
4	980795587G	SPARK PLUG	1	
5	15400PLMA01PE	CARTRIDGE, OIL FILTER.....	1.....	REPLACES P/N 15400RTA004

PARTS MANUAL

HERE'S HOW TO GET HELP

PLEASE HAVE THE MODEL AND SERIAL
NUMBER ON-HAND WHEN CALLING

UNITED STATES

Multiquip Inc.

(310) 537- 3700
6141 Katella Avenue Suite 200
Cypress, CA 90630
E-MAIL: mq@multiquip.com
WEBSITE: www.multiquip.com

CANADA

Multiquip

(450) 625-2244
4110 Industriel Boul.
Laval, Quebec, Canada H7L 6V3
E-MAIL: infocanada@multiquip.com

UNITED KINGDOM

Multiquip (UK) Limited Head Office

0161 339 2223
Unit 2, Northpoint Industrial Estate, Globe Lane,
Dukinfield, Cheshire SK16 4UJ
E-MAIL: sales@multiquip.co.uk

© COPYRIGHT 2024, MULTIQUIP INC.

Multiquip Inc, the MQ logo are registered trademarks of Multiquip Inc. and may not be used, reproduced, or altered without written permission. All other trademarks are the property of their respective owners and used with permission.

This manual MUST accompany the equipment at all times. This manual is considered a permanent part of the equipment and should remain with the unit if resold.

The information and specifications included in this publication were in effect at the time of approval for printing. Illustrations, descriptions, references and technical data contained in this manual are for guidance only and may not be considered as binding. Multiquip Inc. reserves the right to discontinue or change specifications, design or the information published in this publication at any time without notice and without incurring any obligations.



PN: 23625



Flextool

1956 Dandenong Road, Clayton VIC 3168, Australia

Phone (AUS): 1300 353 986

flextool.com.au

ABN 80 069 961 968

This manual summarises our best knowledge of the product based on the information available at the time of publication. You should read this manual carefully and consider the information in the context of how the product will be used. Our responsibility for products sold is subject to our standard terms and conditions of sale.

DISCLAIMER:

Any advice, recommendation, information, assistance or service provided by us in this manual is given in good faith and is believed by us to be appropriate and reliable. However, any advice, recommendation, information, assistance or service provided by us is provided without liability or responsibility PROVIDED THAT the foregoing shall not exclude, limit, restrict or modify the right entitlements and remedies conferred upon any person or the liabilities imposed upon us by any condition or warranty implied by Commonwealth, State or Territory Act or ordinance void or prohibiting such exclusion limitation or modification. The product can be expected to perform as indicated in this manual so long as operation and operational procedures of the individual products are followed as recommended in this manual.

Design and technical specifications may be subject to changes.

© This publication is copyright. All rights are reserved. Flextool is a registered trade mark of Parchem Construction Supplies Pty Ltd. Multiquip, MQ and Whiteman are registered trade marks of Multiquip Inc.