

PARTS LIST

HYDRAULIC REVERSIBLE
COMPACTOR
MVH-150

405-03202

MIKASA SANGYO CO.,LTD.

PARTS REMARK INDEX

How to read the marks and remarks used in this parts book.

Section 1 : Explanation of Code Use In “MRK” Column

OO : Interchangeable between the new part and the old one.

XX : Not Interchangeable between new and old.

OX : New part is usable for the old machine but the old part is not usable for the new machine.

XO : The old part is usable for the new machine but the new part is not usable for the old machine.

Note : In case of the lack of interchangeability between the new part and old part, a new part may be used by replacing all other parts found in the assembly. In this case, refer to section 2 for instruction on identifying other parts involved in a new assembly.

AD : Newly established(added)

DC : Suspended(discontinued)

NC : Part number changed

QC : Quantity used has been changed

NS : Not supplied individually but supplied in an assembly or a group.

AS : Special part designed to allow interchangeability between new and old part.

CR : Correction

Section 2 : Items Found In “Remark” Column

Serial Numbers - Where indicated, this indicates a serial number range (inclusive) where a particular part is used.

Model Number - Where indicated, this shows that the corresponding part is utilized only with this specific model number or model number variant.

or * : All parts with the same number following # or * belong to the same assembly. this part cannot be interchanged individually with any other assemblies to replace an old part (indicated by #), with a new part(indicated by *), then all other parts of that assembly must be replaced with new ones.

Note : If more than one of the same reference number is listed, the last one listed indicates newest(or latest)part available.

Section 3: Example

REF NO.	PART NO.	PART NAME	QTY	MRK	REMARKS
457(1)	5122-09230	Hinge Metal, Upper/24g	1		-1070 #3 (5)
457(2)	5072-09420	Hinge Metal, Upper M16	1	OX(3)	U1071-(6) * 3(7)

(1) Old part

(2) New part

(3) New part usable with old machine, but old part not usable with new machine (reference section 1).

(4) Old part number is used through this machine serial number.

(5) Old part, used in an assembly with other parts marked with #3. To use this part on a new machine, all other parts in this assembly must be replaced with old ones.

(6) New part put into use starting with this serial number and is still current.

(7) New part used in an assembly with other parts marked * 3, to use this part as a replacement for an old part, all other * 3 marked parts must be changed at the same time.

Section 4: Items Found In “MK2” Column

(only for suspended products)

! OO (“OO” is shown in figure) : The part shown in lower line is supplied.

! SD : Not available due to termination of production.

! NS : Not supplied individually, but supplied in an assembly or a group.

! PD : Supplied as unit product.

SS : Not available after stock run out.

(The contents of this parts catalog are subject to change without notice.)

MVH-150

4JJ0

1. VIBRATING PLATE / 輾压盤關係

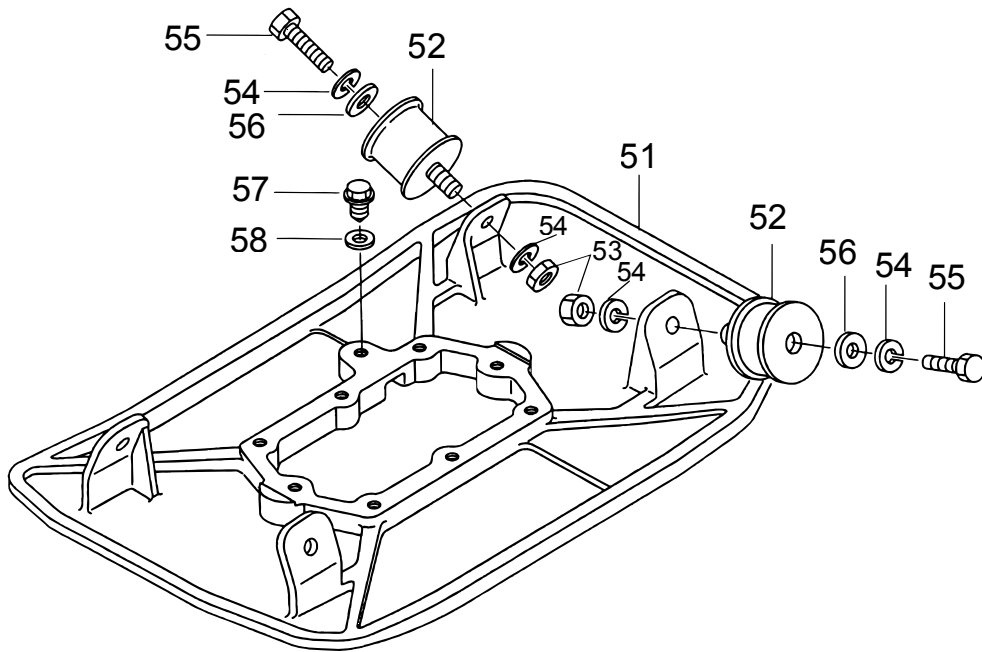

MVH-150

2009/12/18

1. VIBRATING PLATE / 輾压盤關係

** 4JJ

**

REF NO.	PART NO.	PART NAME	Q' TY	MRK	MK2	REMARKS
51	4591-15390	VIBRATING PLATE/MVH-150	1			150
52	9390-10130	SHOCK ABSORBER MED-70S	4			150
53	0203-12100	NUT M12	4			
54	0302-12300	SW M12	8			
55	0012-21230	BOLT 12X30 T	4			150
56	9524-05600	WASHER 12.5X35X4.5	4		SX	
57	4604-49160	OIL GAUGE /MVR-65W	1			
58	9534-05260	PACKING 1/4 (CU)	1			

MVH-150

4MU0

2-1. BODY / 本体関係 (HONDA GX200)

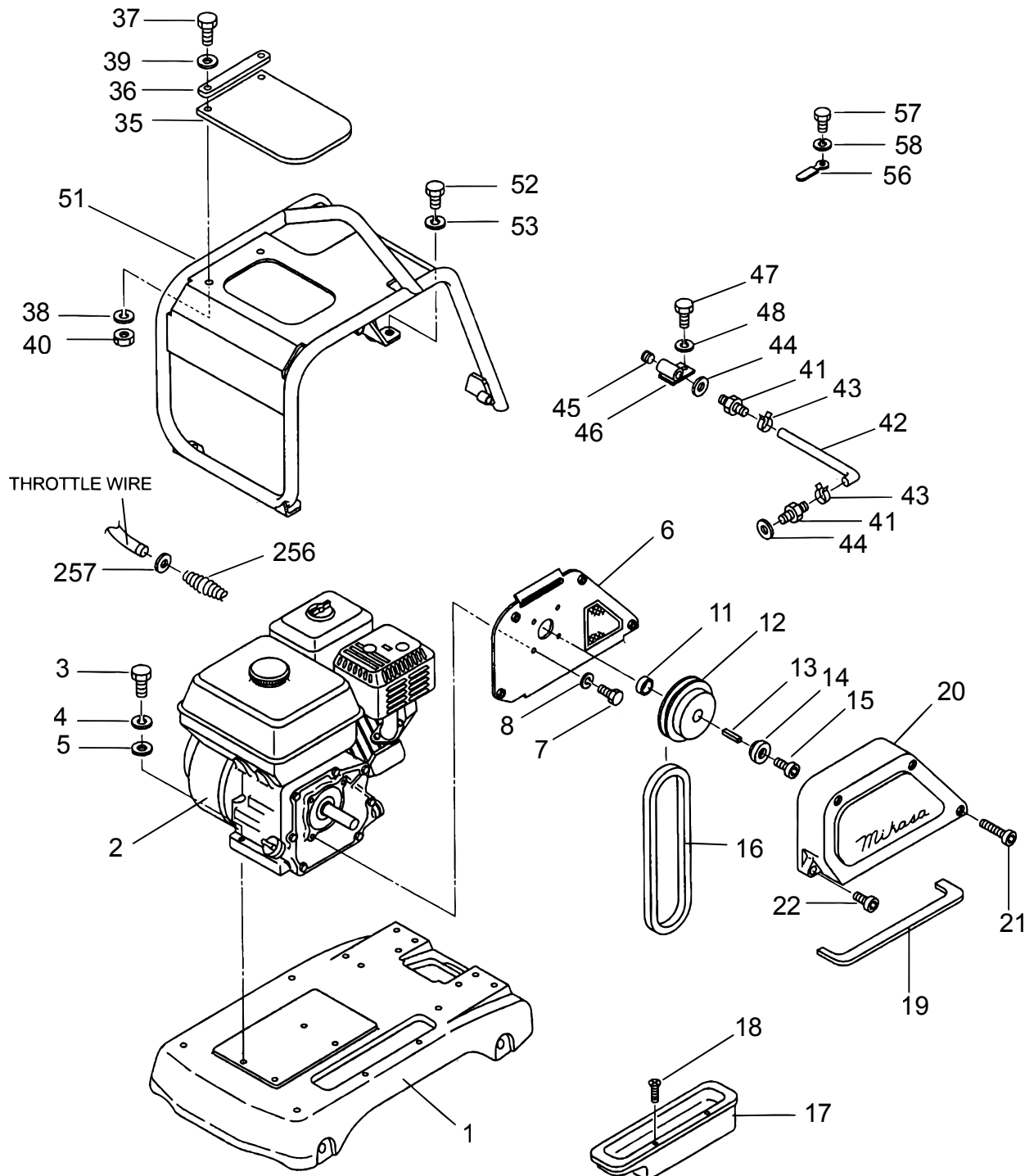

MVH-150

2009/12/18

2-1. BODY / 本体関係 (HONDA GX200)

** 4MU

**

REF NO.	PART NO.	PART NAME	Q' TY	MRK	MK2	REMARKS
1	4591-15760	BASE(GX200)/MVH-150	1			
2	9122-20003	ENGINE AY GX200/MVH JPN	1			FOR JPN
2	9122-20004	ENGINE AY GX200SM12/MQ	1		!9122-20007	FOR MQ
2	9122-02007		1			FOR MQ
2	9122-20005	ENGINE AY GX200/MVH EXP	1		SS!9122-20007	FOR EXP
3	0012-20835	BOLT 8X35 T	4			
4	0302-08200	SW M8	4			
5	0311-08160	PW M8	4			
6	4592-14550	BELT COVER PLATE(GX200)	1		SX	
7	0012-20820	BOLT 8X20 T	4			
8	0302-08200	SW M8	4			
11	4584-51370	SPACER 202512 /MVH-120	1			
12	4583-37770	CLUTCH AY A1-124-20/MVH12	1			
12 -1	9410-20030	CLUTCH SHOE T90T	3			
12 -2	9410-30230	CLUTCH SPRING	2			
12 -3	0460-06006	BEARING 6006DDU	1			
13	032-00501-50	KEY	1			
14	4584-51380	CLUTCH WASHER /MVH-120	1		SX	
15	0015-20825	SOCKET HEAD BOLT 8X25 T	1			
16	0701-00352	V-BELT A-35/RPF3350	1			
17	4592-14530	DUST COVER/MVH-150	1			
18	0920-06010	FLAT HEAD SCREW 6X10	2			
19	4593-38190	SPONGE, DUST COVER/MVH-150	1			
20	4591-15420	BELT COVER(UPPER)/MVH-150	1		SX	
21	0015-20852	SOCKET HEAD BOLT 8X60 T	3			
22	0015-20820	SOCKET HEAD BOLT 8X20 T	1			
35	4584-50830	RUBBER COVER /MVH-120	1			
36	4584-50810	PLATE, RUBBER COVER/MVH120	1		SX	
37	0012-20825	BOLT 8X25 T	2			
38	0302-08200	SW M8	2			
39	0311-08160	PW M8	2			
40	0227-10809	NYLON NUT M8	2			
41	15550-ZK8-P90	DRAIN JOINT	2			
42	15552-ZB9-000	DRAIN HOSE	1			
43	95002-4120008	HOSE CLAMP	2			
43	9540-10070	HOSE BAND 11.5D	2	00		
44	90601-ZE1-000	WASHER, DRAIN PLUG	2			
45	5050-15380	PLUG PT1/4	1			
46	4594-52170	JOINT /MVH-150	1			
47	0012-20820	BOLT 8X20 T	1			
48	0302-08200	SW M8	1			
51	4591-15490	GUARD FRAME(GX200)/MVH150	1		SX	
52	0012-21225	BOLT 12X25 T	4			
53	0302-12300	SW M12	4			
56	226-75101-03	CLAMP	1			
57	0012-20610	BOLT 6X10 T	1			
58	0302-06150	SW M6	1			
256	083-00000-10	COIL SPRING	1	DC		
257	0311-04080	PW M4	1	DC		

MVH-150

4MX0

2-2. BODY / 本体関係 (ROBIN EH25)

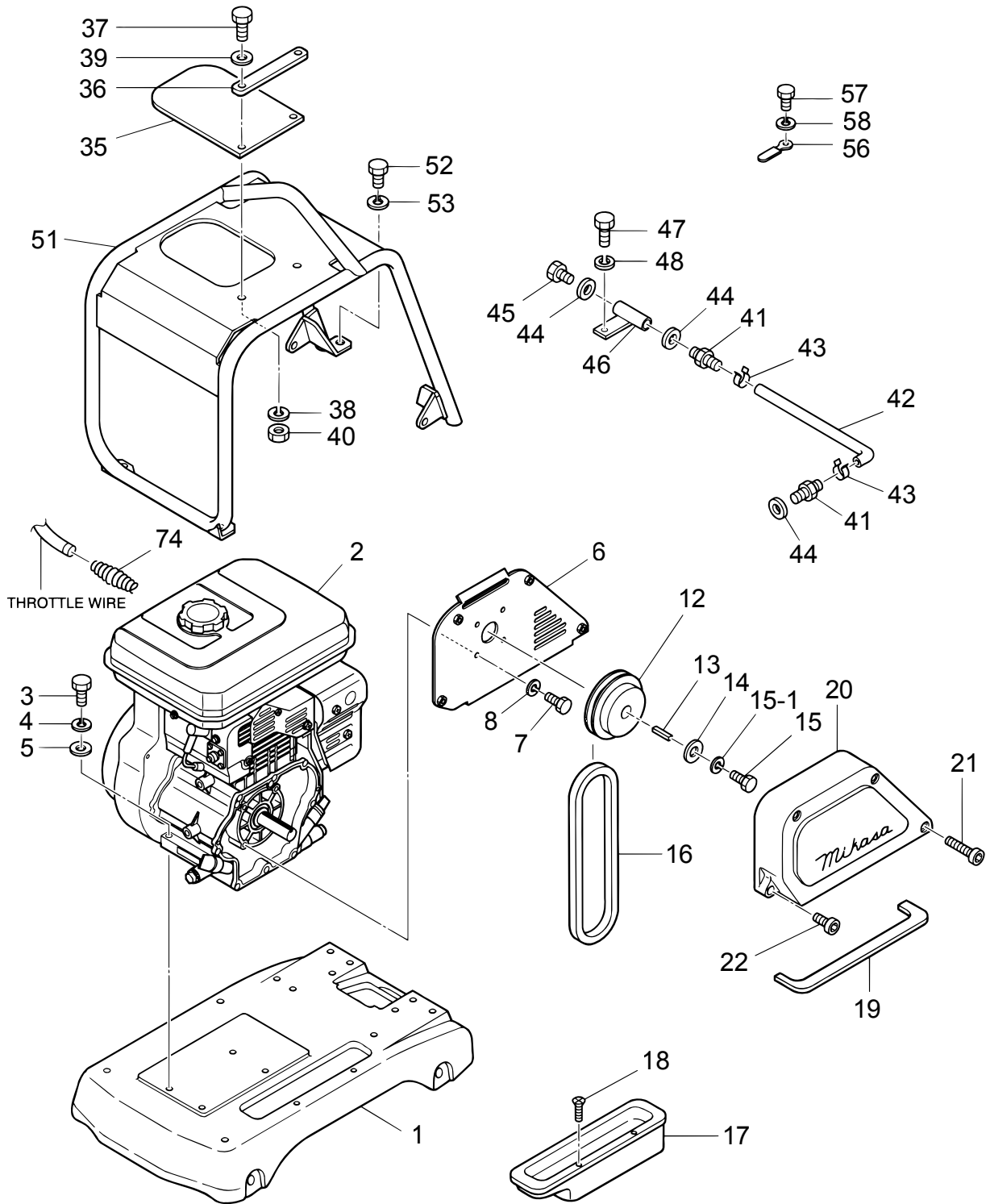

MVH-150

2009/12/18

2-2. BODY /本体関係 (ROBIN EH25)

** 4MX

**

REF NO.	PART NO.	PART NAME	Q' TY	MRK	MK2	REMARKS
1	4591-16340	BASE (EH25) /MVH-150	1			
2	9112-12507	ENGINE AY EH25/MVH150-EXP	1			FOR EXPORT
3	0012-21040	BOLT 10X40 T	4			
4	0302-10250	SW M10	4			
5	0311-10160	PW M10	4			
6	4592-15540	BELT COVER PLATE (EH25)	1			
7	0012-20820	BOLT 8X20 T	4			-N2937
7	001-04802-00	FRANGE BOLT	4			N2938-
8	0302-08200	SW M8	4			-N2937
12	4593-40030	CLUTCH AY (MVH150/EH25)	1		SX	
13	9514-00110	KEY 7X7X35	1			
14	9524-00690	WASHER 9X35X4.5	1			
15	0012-20820	BOLT 8X20 T	1			
15 -1	0302-08200	SW M8	1			
16	0701-00352	V-BELT A-35/RPF3350	1			
17	4592-14530	DUST COVER/MVH-150	1			
18	0920-06010	FLAT HEAD SCREW 6X10	2			
19	4593-38190	SPONGE, DUST COVER/MVH-150	1			
20	4591-15420	BELT COVER (UPPER) /MVH-150	1		SX	
21	0015-20852	SOCKET HEAD BOLT 8X60 T	3			
22	0015-20820	SOCKET HEAD BOLT 8X20 T	1			
35	4584-50830	RUBBER COVER /MVH-120	1			
36	4584-50810	PLATE, RUBBER COVER/MVH120	1		SX	
37	0012-20825	BOLT 8X25 T	2			
38	0302-08200	SW M8	2			
39	0311-08160	PW M8	2			
40	0227-10809	NYLON NUT M8	2			
41	255-63901-11	UNION	2			
42	255-63801-03	DRAIN HOSE	1			
43	009-17200-00	HOSE CLAMP	2			
44	021-11400-20	GASKET	3			
45	040-11400-30	PLUG	1			
46	4594-54460	JOINT BLOCK /MVH-150	1			
47	0012-20820	BOLT 8X20 T	1			
48	0302-08200	SW M8	1			
51	4591-16330	GUARD FRAME (EH25) /MVH-150	1			
52	0012-21225	BOLT 12X25 T	4			
53	0302-12300	SW M12	4			
56	226-75101-03	CLAMP	1			
57	0012-20610	BOLT 6X10 T	1			
58	0302-06150	SW M6	1			
74	234-46002-13	RETURN SPRING	1	DC		

MVH-150

4MV0

2-3. BODY / 本体関係 (ROBIN DY23D)

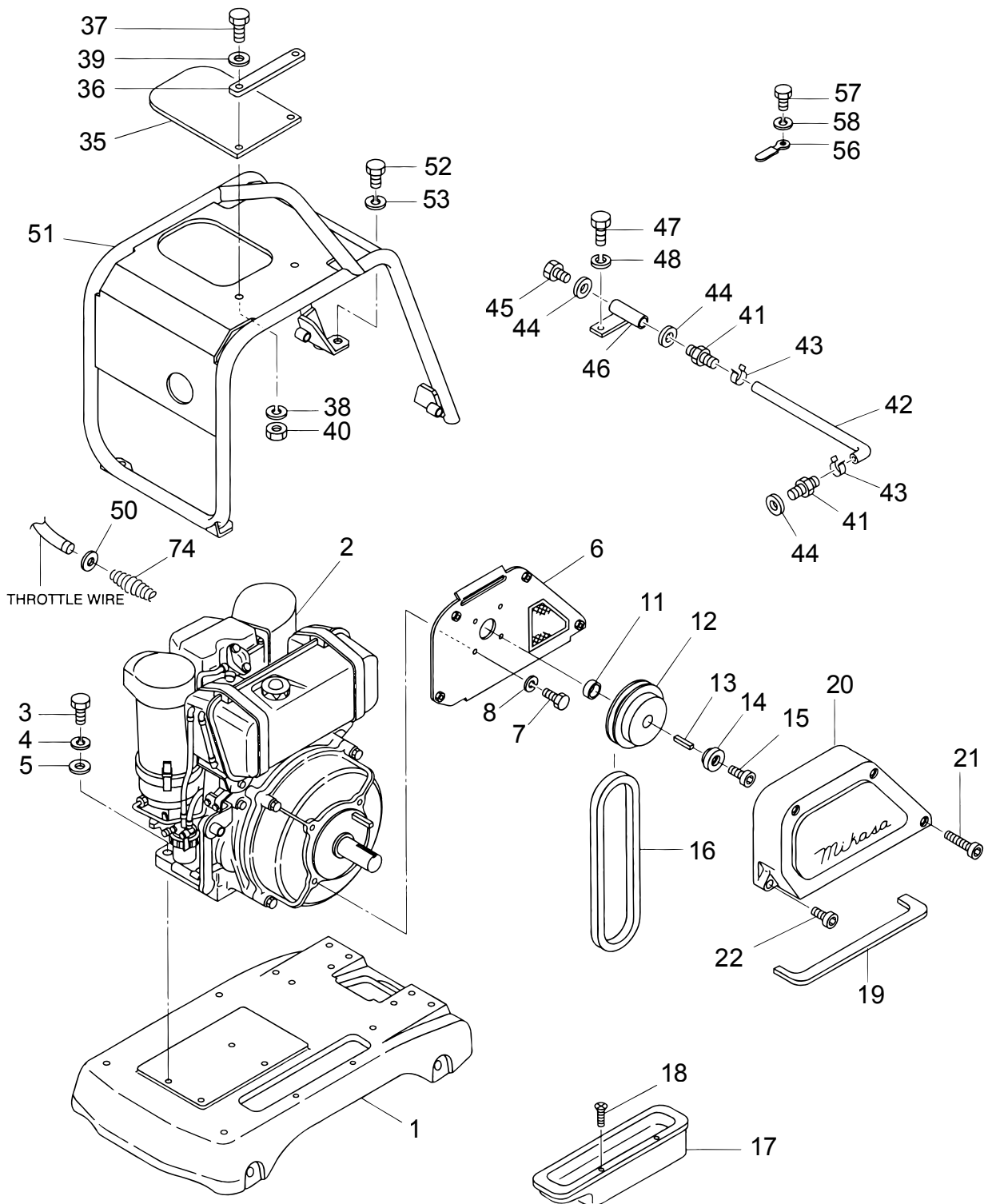

MVH-150

2009/12/18

2-3. BODY /本体関係 (ROBIN DY23D)

** 4MV

**

REF NO.	PART NO.	PART NAME	Q'TY	MRK	MK2	REMARKS
1	4591-15750	BASE (DY23) /MVH-150	1			
2	9114-02303	ENGINE AY DY23D/MVH JPN	1			FOR JPN
2	9114-02308	ENGINE AY DY23D/MVH MQ	1			FOR MQ
2	9114-02309	ENGINE AY DY23D/MVH EXP	1			FOR EXP
3	0012-21050	BOLT 10X50 T	4			
4	0302-10250	SW M10	4			
5	0311-10160	PW M10	4			
6	4592-14440	BELT COVER PLATE (DY23)	1			
7	0012-20820	BOLT 8X20 T	4			
8	0302-08200	SW M8	4			
11	4584-51370	SPACER 202512 /MVH-120	1			
12	4583-37770	CLUTCH AY A1-124-20/MVH12	1			
12 -1	9410-20030	CLUTCH SHOE T90T	3			
12 -2	9410-30230	CLUTCH SPRING	2			
12 -3	0460-06006	BEARING 6006DDU	1			
13	032-00501-50	KEY	1			
14	4584-51380	CLUTCH WASHER /MVH-120	1		SX	
15	0015-20820	SOCKET HEAD BOLT 8X20 T	1			
16	0701-00342	V-BELT A-34/RPF3340	1			
17	4592-14530	DUST COVER/MVH-150	1			
18	0920-06010	FLAT HEAD SCREW 6X10	2			
19	4593-38190	SPONGE, DUST COVER/MVH-150	1			
20	4591-15420	BELT COVER (UPPER) /MVH-150	1		SX	
21	0015-20852	SOCKET HEAD BOLT 8X60 T	3			
22	0015-20820	SOCKET HEAD BOLT 8X20 T	1			
35	4584-50830	RUBBER COVER /MVH-120	1			
36	4584-50810	PLATE, RUBBER COVER/MVH120	1		SX	
37	0012-20825	BOLT 8X25 T	2			
38	0302-08200	SW M8	2			
39	0311-08160	PW M8	2			
40	0227-10809	NYLON NUT M8	2			
41	255-63901-11	UNION	2			
42	255-63801-03	DRAIN HOSE	1			
43	009-17200-00	HOSE CLAMP	2			
44	021-11400-20	GASKET	3			
45	040-11400-30	PLUG	1			
46	4594-54460	JOINT BLOCK /MVH-150	1			
47	0012-20820	BOLT 8X20 T	1			
48	0302-08200	SW M8	1			
50	0311-04080	PW M4	1	DC		
51	4591-15410	GUARD FRAME (DY23) /MVH150	1			
52	0012-21225	BOLT 12X25 T	4			
53	0302-12300	SW M12	4			
56	226-75101-03	CLAMP	1			
57	0012-20610	BOLT 6X10 T	1			
58	0302-06150	SW M6	1			
74	234-46002-13	RETURN SPRING	1	DC		

MVH-150

4MW0

2-4. BODY / 本体関係 (ROBIN DY23DS)

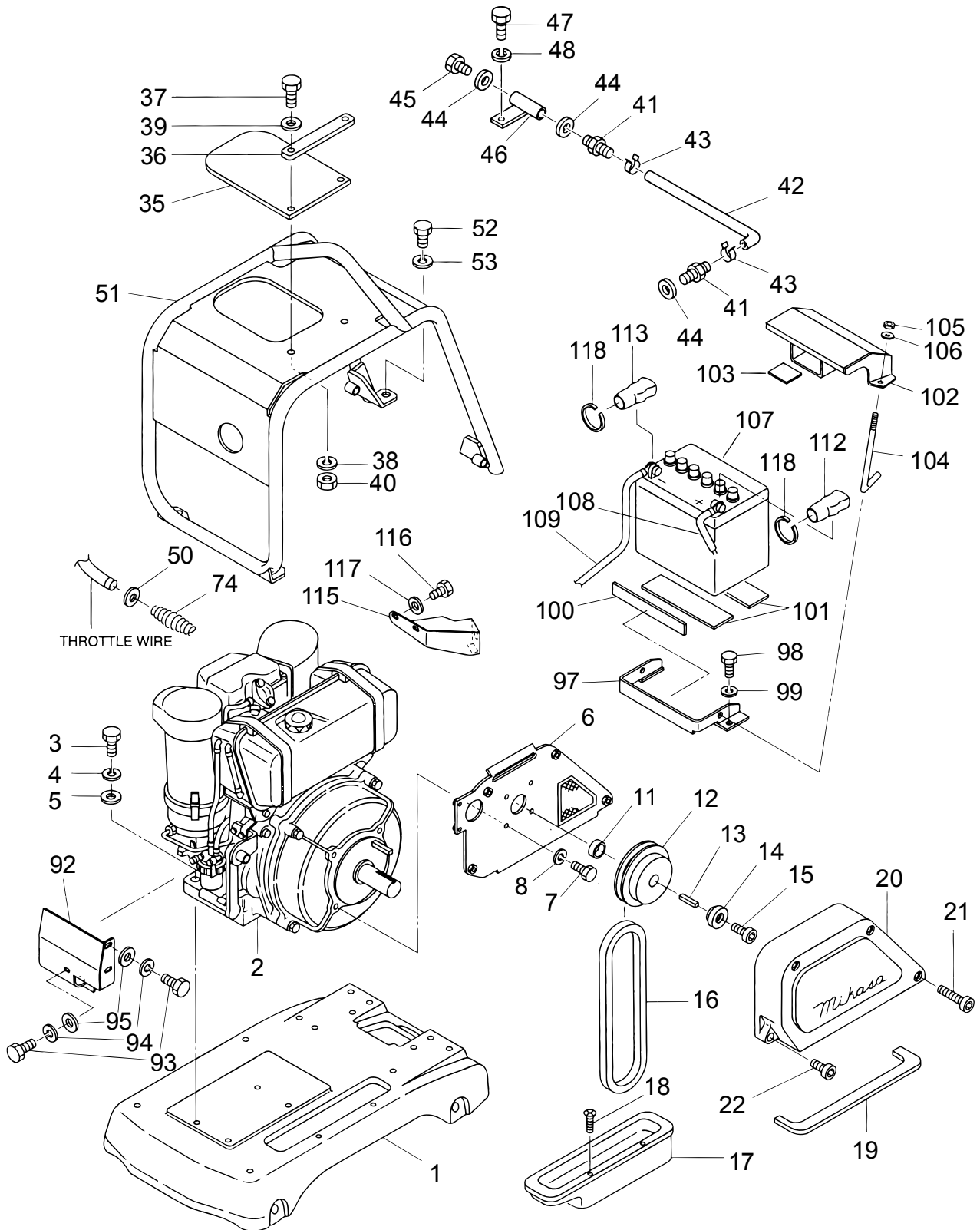

2-4. BODY /本体関係 (ROBIN DY23DS)

** 4MW

**

REF NO.	PART NO.	PART NAME	Q' TY	MRK	MK2	REMARKS
1	4591-15750	BASE(DY23)/MVH-150	1			
2	9114-02304	ENGINE AY DY23DS/MVH JPN	1		!SD	FOR JPN
2	9114-02310	ENGINE AY DY23DS/MVH EXP	1			FOR EXP
3	0012-21050	BOLT 10X50 T	4			
4	0302-10250	SW M10	4			
5	0311-10160	PW M10	4			
6	4592-14690	BELT COVER PLATE(DY23DS)	1		SX	
7	0012-20820	BOLT 8X20 T	4			
8	0302-08200	SW M8	4			
11	4584-51370	SPACER 202512 /MVH-120	1			
12	4583-37770	CLUTCH AY A1-124-20/MVH12	1			
12 -1	9410-20030	CLUTCH SHOE T90T	3			
12 -2	9410-30230	CLUTCH SPRING	2			
12 -3	0460-06006	BEARING 6006DDU	1			
13	032-00501-50	KEY	1			
14	4584-51380	CLUTCH WASHER /MVH-120	1		SX	
15	0015-20820	SOCKET HEAD BOLT 8X20 T	1			
16	0701-00342	V-BELT A-34/RPF3340	1			
17	4592-14530	DUST COVER/MVH-150	1			
18	0920-06010	FLAT HEAD SCREW 6X10	2			
19	4593-38190	SPONGE, DUST COVER/MVH-150	1			
20	4591-15420	BELT COVER(UPPER)/MVH-150	1		SX	
21	0015-20852	SOCKET HEAD BOLT 8X60 T	3			
22	0015-20820	SOCKET HEAD BOLT 8X20 T	1			
35	4584-50830	RUBBER COVER /MVH-120	1			
36	4584-50810	PLATE, RUBBER COVER/MVH120	1		SX	
37	0012-20825	BOLT 8X25 T	2			
38	0302-08200	SW M8	2			
39	0311-08160	PW M8	2			
40	0227-10809	NYLON NUT M8	2			
41	255-63901-11	UNION	2			
42	255-63801-03	DRAIN HOSE	1			
43	009-17200-00	HOSE CLAMP	2			
44	021-11400-20	GASKET	3			
45	040-11400-30	PLUG	1			
46	4594-54460	JOINT BLOCK /MVH-150	1			
47	0012-20820	BOLT 8X20 T	1			
48	0302-08200	SW M8	1			
50	0311-04080	PW M4	1	DC		
51	4591-15410	GUARD FRAME(DY23)/MVH150	1			
52	0012-21225	BOLT 12X25 T	4			
53	0302-12300	SW M12	4			
74	234-46002-13	RETURN SPRING	1	DC		
92	4592-14670	COVER, DYNAMO/MVH-150	1			
93	0012-20616	BOLT 6X16 T	4			
94	0302-06150	SW M6	4			
95	0311-06100	PW M6	4			
97	4592-14590	BATTERY HOLDER/MVH-150	1			
98	0012-21020	BOLT 10X20 T	2			
99	0302-10250	SW M10	2			
100	4594-51890	RUBBER PLATE 190X28X3	1			
101	4594-51870	CUSHION(BATTERY) 190X50X10	2			
102	4592-14600	BATTERY COVER/MVH-150	1		SX	
103	4594-51880	RUBBER PLATE 50X45X3	5			
104	4594-51900	BATTERY BOLT 145L/MVH-150	2			
105	0227-10809	NYLON NUT M8	2			
106	0311-08160	PW M8	2			
107	9550-10012	BATTERY 30A19L	1		!NS	
108	4594-52130	BATTERY CORD(+) 530L/MVH	1			
109	4594-52140	BATTERY CORD(-) 260L/MVH	1			
112	9553-00460	TERMINAL COVER (+)	1			
113	9553-00470	TERMINAL COVER (-)	1			
115	4592-14680	HOLDER, SWITCH/MVH-150	1			
116	0015-20812	SOCKET HEAD BOLT 8X12 T	2			
117	0311-08160	PW M8	2			
118	5060-10070	CLAMP TC-150	3			

MVH-150

4LG0

2-5. BODY / 本体関係 (YANMAR L48)

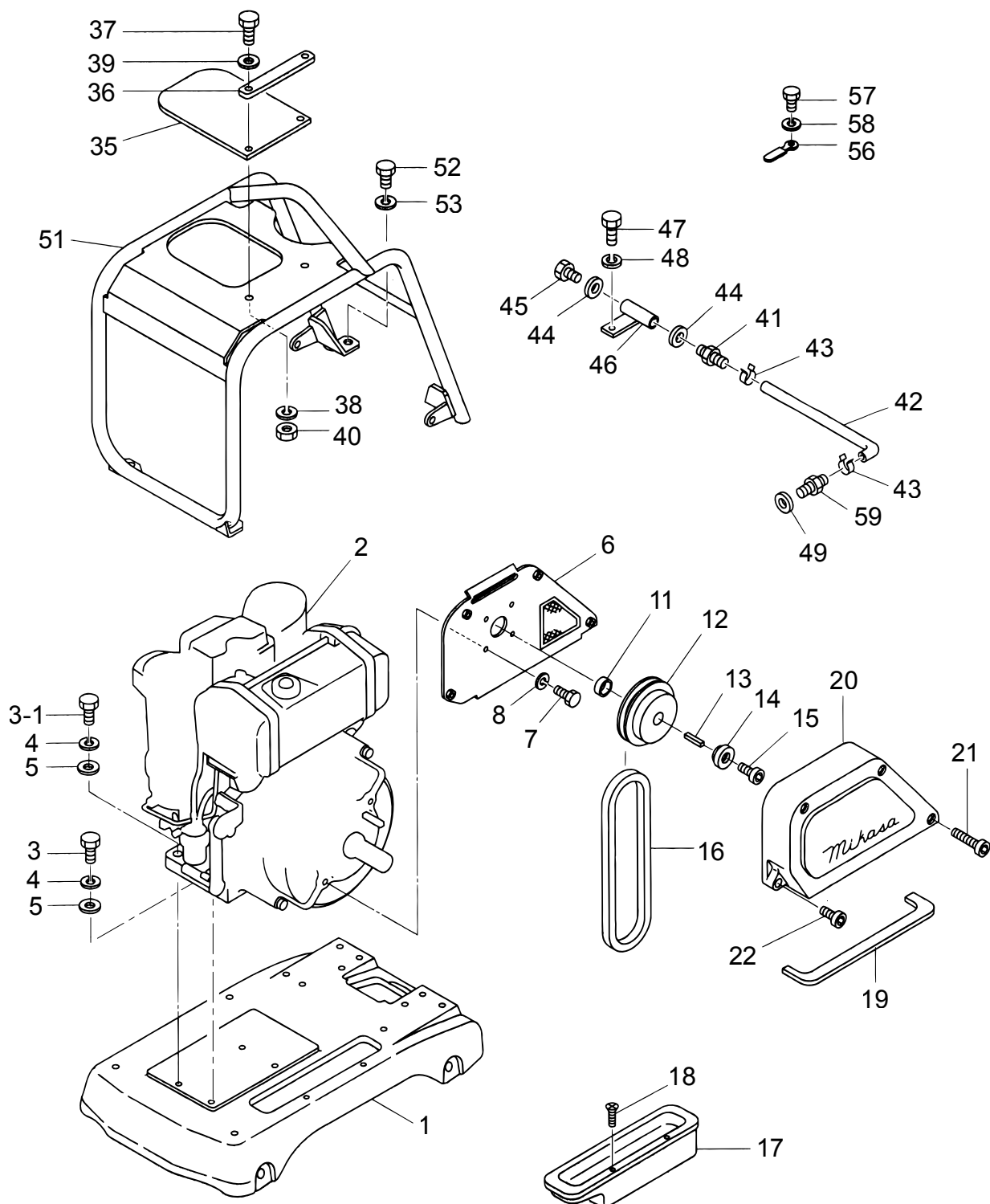

MVH-150

2009/12/18

2-5. BODY / 本体関係 (YANMAR L48)

** 4LG

**

REF NO.	PART NO.	PART NAME	Q' TY	MRK	MK2	REMARKS
1	4591-16670	BASE(L48) /MVH-150	1			
2	9144-10011	ENGINE AY L48EE	1	DC	!SD	#4 -K1859
2	9144-10011	ENGINE AY L48EE	1	AD	!SD	*4 K1860-
2	9144-10017	ENGINE AY L48A / MVC-98D	1			EXP
3	0012-21040	BOLT 10X40 T	4			
3	0012-21040	BOLT 10X40 T	3	QC		*4 K1860-
3 -1	0012-21035	BOLT 10X35 T	1	AD		*4 K1860-
4	0302-10250	SW M10	4			
5	0311-10160	PW M10	4			
6	4592-14440	BELT COVER PLATE(DY23)	1	DC		#4 -K1859
6	4592-16380	BELT COVER PLATE(L48EE)	1	AD		*4 K1860-
7	0012-20820	BOLT 8X20 T	4			
8	0302-08200	SW M8	4			
11	4584-51370	SPACER 202512 /MVH-120	1			
12	4583-37770	CLUTCH AY A1-124-20/MVH12	1			
12 -1	9410-20030	CLUTCH SHOE T90T	3			
12 -2	9410-30230	CLUTCH SPRING	2			
12 -3	0460-06006	BEARING 6006DDU	1			
13	9514-06780	KEY 5X5X30 RR	1		!22512-050300	
14	4584-51380	CLUTCH WASHER /MVH-120	1		SX	
15	0015-20825	SOCKET HEAD BOLT 8X25 T	1			
16	0701-00352	V-BELT A-35/RPF3350	1			
17	4592-14530	DUST COVER/MVH-150	1			
18	0920-06010	FLAT HEAD SCREW 6X10	2			
19	4593-38190	SPONGE, DUST COVER/MVH-150	1			
20	4591-15420	BELT COVER(UPPER)/MVH-150	1		SX	
21	0015-20852	SOCKET HEAD BOLT 8X60 T	3			
22	0015-20820	SOCKET HEAD BOLT 8X20 T	1			
35	4584-50830	RUBBER COVER /MVH-120	1			
36	4584-50810	PLATE, RUBBER COVER/MVH120	1		SX	
37	0012-20825	BOLT 8X25 T	2			
38	0302-08200	SW M8	2			
39	0311-08160	PW M8	2			
40	0227-10809	NYLON NUT M8	2			
41	255-63901-11	UNION	1			
42	255-63801-03	DRAIN HOSE	1			
43	009-17200-00	HOSE CLAMP	2			
44	021-11400-20	GASKET	2			
45	040-11400-30	PLUG	1			
46	4594-54460	JOINT BLOCK /MVH-150	1			
47	0012-20820	BOLT 8X20 T	1			
48	0302-08200	SW M8	1			
49	22190-160002	SEAL WASHER 16S	1			
51	4591-16680	GUARD FRAME(L48)/MVH-150	1		SX	
52	0012-21225	BOLT 12X25 T	4			
53	0302-12300	SW M12	4			
56	9544-06820	CORD CLAMP	1		!!160802-78260	
56	160802-78260	CLAMP	1			
57	0012-20610	BOLT 6X10 T	1			
58	0302-06150	SW M6	1			
59	4594-55560	UNION, OIL DRAIN(L48)/MVH	1			

MVH-150DSB (YANMAR L48Vセル付)

4PG0

2-6. BODY / 本体関係 (機No. R3641~)

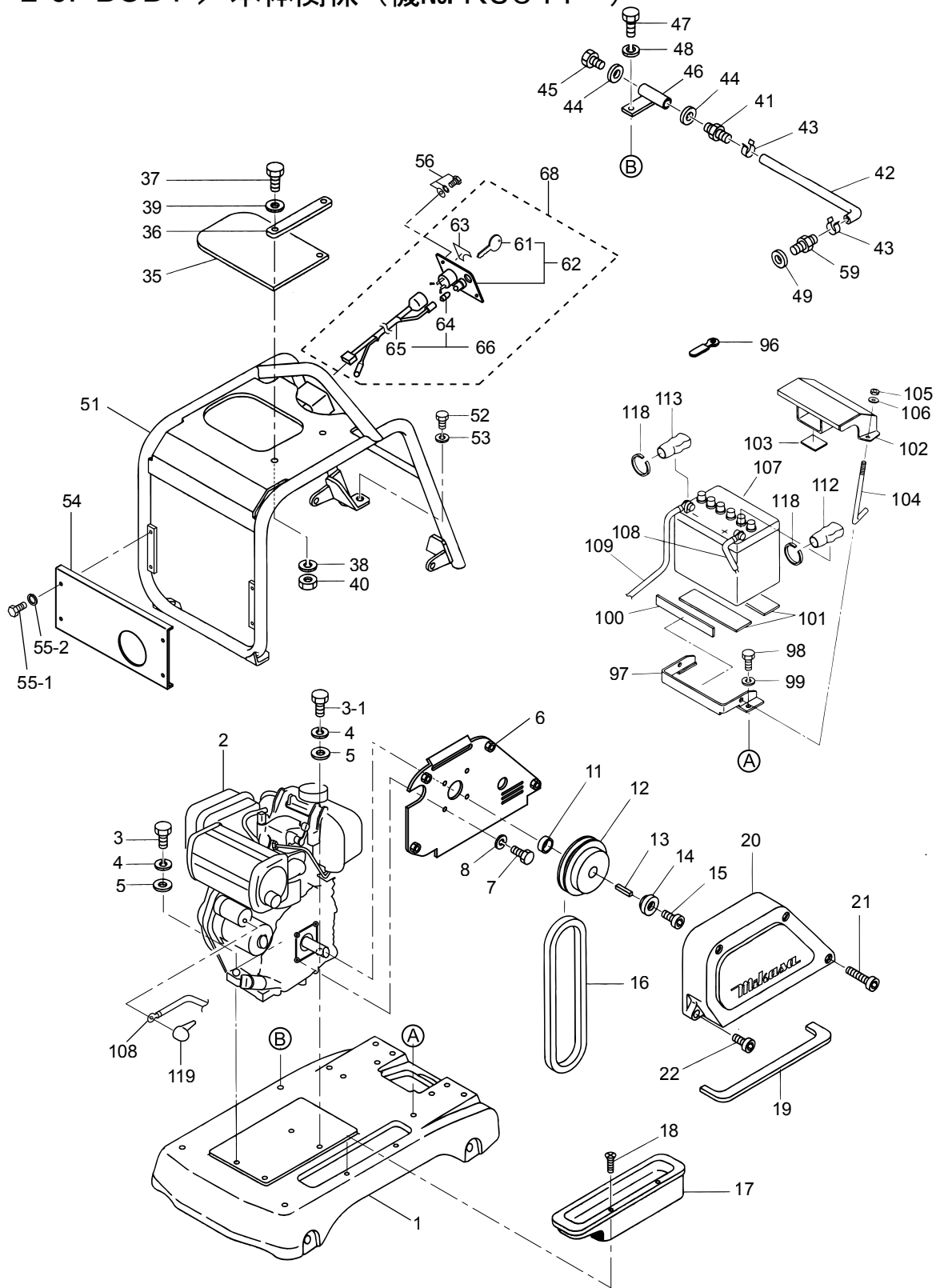

REF NO.	PART NO.	PART NAME	Q'TY	MRK	MR2	REMARKS
1	4591-16670	BASE(L48) /MVH-150	1			
2	9144-10030	ENGINE AY L48V/E. START/JP	1		SX	
3	0012-21040	BOLT 10X40 T	3			
3 -1	0012-21035	BOLT 10X35 T	1			
4	0302-10250	SW M10	4			
5	0311-10160	PW M10	4			
6	4592-17550	BELT COVER PLATE/L48V/DSB	1			
7	0012-20820	BOLT 8X20 T	4			
8	0302-08200	SW M8	4			
11	4584-51370	SPACER 202512 /MVH-120	1			
12	4583-37770	CLUTCH AY A1-124-20/MVH12	1			
12 -1	9410-20030	CLUTCH SHOE T90T	3			
12 -2	9410-30230	CLUTCH SPRING	2			
12 -3	0460-06006	BEARING 6006DDU	1			
13	9514-06780	KEY 5X5X30 RR	1		!22512-050300	
14	4584-51380	CLUTCH WASHER /MVH-120	1		SX	
15	0015-20820	SOCKET HEAD BOLT 8X20 T	1			
16	0701-00352	V-BELT A-35/RPF3350	1			
17	4592-14530	DUST COVER/MVH-150	1			
18	0920-06010	FLAT HEAD SCREW 6X10	2			
19	4593-38190	SPONGE, DUST COVER/MVH-150	1			
20	4591-15420	BELT COVER (UPPER)/MVH-150	1		SX	
21	0015-20852	SOCKET HEAD BOLT 8X60 T	3			
22	0015-20820	SOCKET HEAD BOLT 8X20 T	1			
35	4584-50830	RUBBER COVER /MVH-120	1			
36	4584-50810	PLATE, RUBBER COVER/MVH120	1		SX	
37	0012-20825	BOLT 8X25 T	2			
38	0302-08200	SW M8	2			
39	0311-08160	PW M8	2			
40	0227-10809	NYLON NUT M8	2			
41	255-63901-11	UNION	1			
42	255-63801-03	DRAIN HOSE	1			
43	009-17200-00	HOSE CLAMP	2			
44	021-11400-20	GASKET	2			
45	040-11400-30	PLUG	1			
46	4594-54460	JOINT BLOCK /MVH-150	1			
47	0012-20820	BOLT 8X20 T	1			
48	0302-08200	SW M8	1			
49	22190-160002	SEAL WASHER 16S	1			
51	4591-19270	GUARD FRAME/L48V/DSB	1			
52	0012-21225	BOLT 12X25 T	4			
53	0302-12300	SW M12	4			
54	4592-17540	FRONT GUARD/L48V/150DSB	1			
55 -1	0012-20815	BOLT 8X15 T	4			
55 -2	0302-08200	SW M8	4			
56	0024-00615	BOLT 6X15 SW, PW	3			
59	4594-55560	UNION, OIL DRAIN(L48) /MVH	1			
61	106100-77630	KEY /150DSB/L48V6	1			
62	106100-77620	KEY SWITCH	1			
63	105198-07120	LABEL, STARTER	1			
64	46150-001110	BULB 12V/3W	1			
65	114351-77520	JOINT	1			
66	114351-77700	HARNES, WIRE	1			
68	114351-77500	KEY SWITCH PANEL CMP	1			
96	160260-78700	CLAMP, WIRE	3			
97	4592-14590	BATTERY HOLDER/MVH-150	1			
98	0012-21020	BOLT 10X20 T	2			
99	0302-10250	SW M10	2			
100	4594-51890	RUBBER PLATE 190X28X3	1			
101	4594-51870	CUSHION(BATTERY) 190X50X10	2			
102	4592-14600	BATTERY COVER/MVH-150	1		SX	
103	4594-51880	RUBBER PLATE 50X45X3	1			
104	4594-51900	BATTERY BOLT 145L/MVH-150	2			
105	0227-10809	NYLON NUT M8	2			
106	0311-08160	PW M8	2			
107	9550-10012	BATTERY 30A19L	1		!NS	
108	4594-60470	BATTERY CORD(+) 430L/MVH	1			
109	4594-52140	BATTERY CORD(-) 260L/MVH	1			
112	9553-00460	TERMINAL COVER (+)	1			
113	9553-00470	TERMINAL COVER (-)	1			
118	5060-10070	CLAMP TC-150	3			
119	4594-60550	TERMINAL COVER (ENGINE)	1			

MVH-150

4JN0

3-1. VIBRATOR/起振体関係

(OLD/旧型 MVH-150 Serial No. G1001~No. L2169)

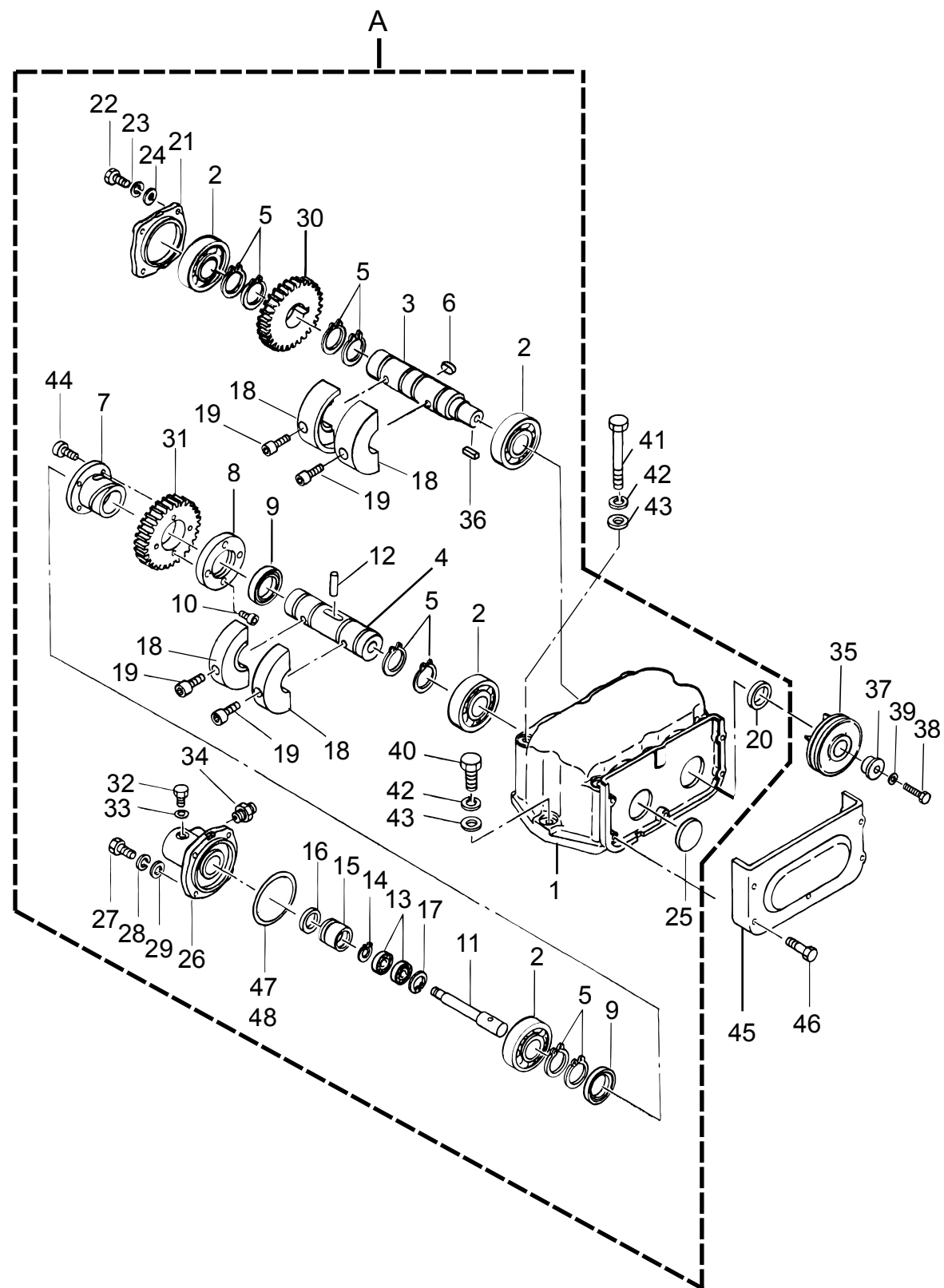

3-1. VIBRATOR/起振体関係

** 4JN

**

REF NO.	PART NO.	PART NAME	Q' TY	MRK	MK2	REMARKS
A	4599-10010	VIBRATOR ASSY/MVH-150	1	DC	!R000225	G1001-L2169
A	4599-10011	VIBRATOR ASSY/MVH-150	1	DC	!R000225	L2170-R3348
A	4599-10012	VIBRATOR AY / MVH-150NN	1	DC	!R000225	R3384-R3879
A	4599-10013	VIBRATOR AY/MVH-150N3	1			R3880-
1	4581-15150	VIBRATING CASE /MVH-120	1			
2	0479-20090	ROLLER BEARING NJ307MC4	4			150
3	4583-37700	ROTARY SHAFT, DRIVE/MVH120	1		SX	
4	4583-37710	ROTARY SHAFT, DRIVEN/MVH12	1	DC		
5	0802-00350	STOP RING S-35	8			
6	9514-05460	KEY 10X8X19 RR	1			
7	4583-37720	CAM RING 210 /MVH-120	1	DC	SS!SD	
8	4583-37850	BEARING HOLDER /MVH-120	1	DC		
9	0403-06807	BEARING 6807C3	2	DC		
10	0015-20630	SOCKET HEAD BOLT 6X30 T	4	DC		
11	4583-37730	PISTON ROD /MVH-120	1			
12	0255-08050	PIN 8X50	1		SX	
13	0425-06000	BEARING 6000ZZSG	2			
14	0802-00100	STOP RING S-10	1			
15	4554-35051	PISTON, 22.4D /MVH-200	1			
16	4550-10070	PACKING USH-22.4X30X5	1			
17	0801-00260	STOP RING R-26	1			
18	4594-51850	ECCENTRIC ROTATOR/MVH-150	4			150
19	0091-20306	SOCKET HEAD BOLT 10X30T	4			150
20	0602-02040	OIL SEAL SC-28458	1			
21	4583-37740	BEARING COVER /MVH-120	1			
22	0012-20820	BOLT 8X20 T	4			
23	0302-08200	SW M8	4			
24	0311-08160	PW M8	4			
25	9534-05580	SEAL CAP SC-458 /MVR-65W	1			
26	4582-14370	CYLINDER /MVH-120	1			
27	0012-20820	BOLT 8X20 T	4			
28	0302-08200	SW M8	4			
29	0311-08160	PW M8	4			
30	4603-33000	GEAR (DRIVE) /MVR-65W	1		SX/SS!SD	G1001-L2169
31	4583-37840	GEAR (DRIVEN) /MVH-120	1		SX	G1001-L2169
32	0012-20812	BOLT 8X12 T	1		SX	
33	9534-04600	COPPER PACKING 8X16X2	1		SX	
34	9540-10020	CONNECTOR PT, PF1/4	1			
35	4593-38460	PULLEY 83D W/FAN /MVH-150	1			GX200/EH25
35	4593-38450	PULLEY 80D W/FAN /MVH-150	1			DY23D/DS
35	4593-41310	PULLEY 90D W/FAN /MVH-150	1			L48
35	4593-38450	PULLEY 80D W/FAN /MVH-150	1			L48EU N2788-
36	9514-00990	KEY 7X7X20	1			
37	4594-52100	WASHER 9X(24-30)X17/MVH	1			150
38	0012-20835	BOLT 8X35 T	1			150
39	0302-08200	SW M8	1			
40	0012-21235	BOLT 12X35 T	2			
40	0012-21240	BOLT 12X40 T	2	OX		G1146-
41	0012-21264	BOLT 12X120 T	6			
42	0302-12300	SW M12	8			
43	0311-12230	PW M12	8			
44	0015-20620	SOCKET HEAD BOLT 6X20 T	4	DC		
45	4592-14510	BELT COVER (LOWER) /MVH-150	1			150
46	0015-20645	SOCKET HEAD BOLT 6X45 T	5			150
47	9524-06170	SHIM 70-80-0.1T /MVH-120	1		!SD	
48	9524-06180	SHIM 70-80-0.2T /MVH-120	1		SX	

MVH-150

4PR0

3-2. VIBRATOR / 起振体関係

(NEW/新型 MVH-150 Serial No. L2170-P3241,P3257-3384)

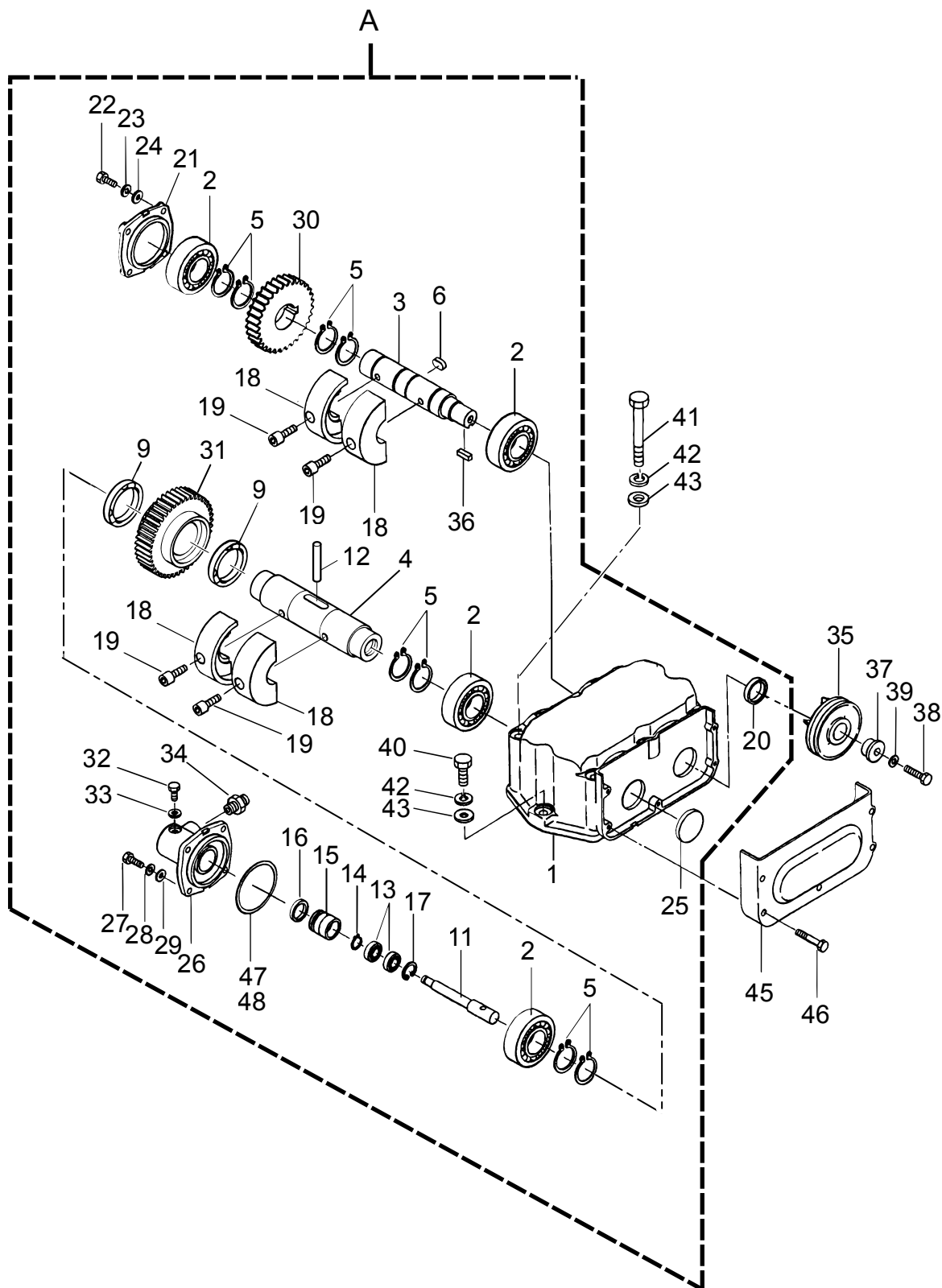

3-2. VIBRATOR/起振体関係

** 4PR

**

REF NO.	PART NO.	PART NAME	Q' TY	MRK	MK2	REMARKS
A	4599-10010	VIBRATOR ASSY/MVH-150	1	DC	!R000225	G1001-L2169
A	4599-10011	VIBRATOR ASSY/MVH-150	1	DC	!R000225	L2170-R3384
A	4599-10012	VIBRATOR AY / MVH-150NN	1	DC	!R000225	R3384-R3879
A	4599-10013	VIBRATOR AY/MVH-150N3	1			R3880-
1	4581-15150	VIBRATING CASE /MVH-120	1			
2	0479-20090	ROLLER BEARING NJ307MC4	4			150
3	4583-37700	ROTARY SHAFT, DRIVE/MVH120	1		SX	
4	4583-42580	ROTARY SHAFT, DRIVEN/NEW	1			
5	0802-00350	STOP RING S-35	8			
6	9514-05460	KEY 10X8X19 RR	1			
9	0403-06907	BEARING 6907C3	2			
11	4583-37730	PISTON ROD /MVH-120	1			
12	0255-08050	PIN 8X50	1		SX	
13	0425-06000	BEARING 6000ZZSG	2			
14	0802-00100	STOP RING S-10	1			
15	4554-35051	PISTON, 22.4D /MVH-200	1			
16	4550-10070	PACKING USH-22.4X30X5	1			
17	0801-00260	STOP RING R-26	1			
18	4594-51850	ECCENTRIC ROTATOR/MVH-150	4			150
19	0091-20306	SOCKET HEAD BOLT 10X30T	4			150
20	0602-02040	OIL SEAL SC-28458	1			
21	4583-37740	BEARING COVER /MVH-120	1			
22	0311-08160	PW M8	4			
23	0302-08200	SW M8	4			
24	0311-08160	PW M8	4			
25	9534-05580	SEAL CAP SC-458 /MVR-65W	1			
26	4582-14370	CYLINDER /MVH-120	1			
27	0012-20820	BOLT 8X20 T	4			
28	0302-08200	SW M8	4			
29	0311-08160	PW M8	4			
30	4603-47340	GEAR (DRIVE) /MVH-150	1			
31	4583-42590	GEAR (DRIVEN) /MVH-120, 150	1			
32	0012-20812	BOLT 8X12 T	1		SX	
33	9534-04600	COPPER PACKING 8X16X2	1		SX	
34	9540-10020	CONNECTOR PT, PF1/4	1			
35	4593-38460	PULLEY 83D W/FAN /MVH-150	1			GX200/EH25
35	4593-38450	PULLEY 80D W/FAN /MVH-150	1			DY23D/DS
35	4593-41310	PULLEY 90D W/FAN /MVH-150	1			L48
36	9514-00990	KEY 7X7X20	1			
37	4594-52100	WASHER 9X(24-30)X17/MVH	1			150
38	0012-20835	BOLT 8X35 T	1			150
39	0302-08200	SW M8	1			
40	0012-21240	BOLT 12X40 T	2			
41	0012-21264	BOLT 12X120 T	6			
42	0302-12300	SW M12	8			
43	0311-12230	PW M12	8			
45	4592-14510	BELT COVER (LOWER) /MVH-150	1			150
46	0015-20645	SOCKET HEAD BOLT 6X45 T	5			150
47	9524-06170	SHIM 70-80-0.1T /MVH-120	1		!SD	
48	9524-06180	SHIM 70-80-0.2T /MVH-120	1		SX	

MVH-150

3-3. VIBRATOR(STOP RING LESS)/ 起振体関係(ストップリングレス) 4PA0

Serial No.P3242-3256,P3385-

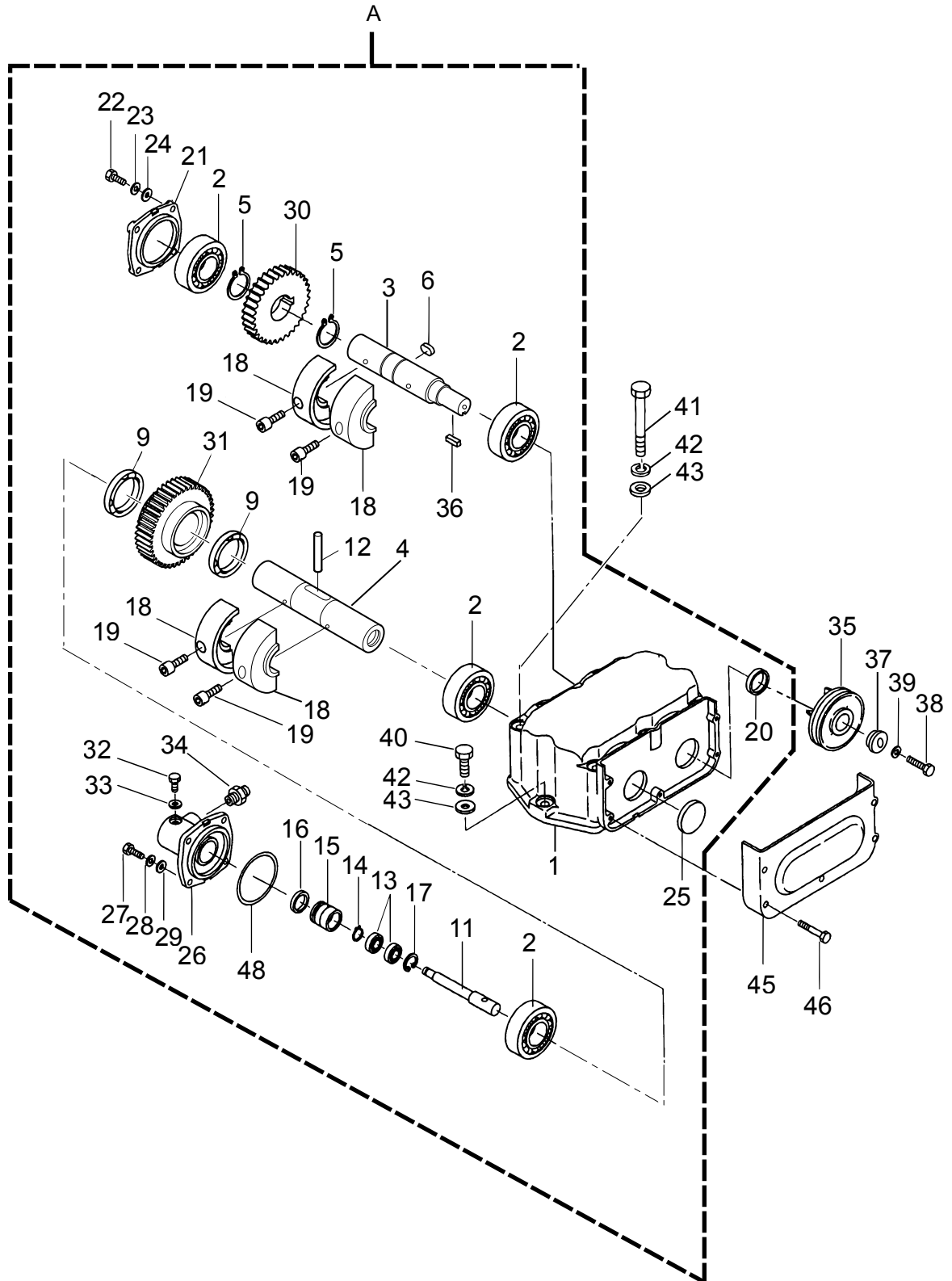

3-3. VIBRATOR (STOP RING LESS) / 起振体関係 (ストップリングレス)

** 4PA

**

REF NO.	PART NO.	PART NAME	Q' TY	MRK	MK2	REMARKS
A	4599-10010	VIBRATOR ASSY/MVH-150	1	DC	!R000225	G1001-L2169
A	4599-10011	VIBRATOR ASSY/MVH-150	1	DC	!R000225	L2170-R3384
A	4599-10012	VIBRATOR AY / MVH-150NN	1	DC	!R000225	R3384-R3879
A	4599-10013	VIBRATOR AY/MVH-150N3	1			R3880-
1	4581-15150	VIBRATING CASE /MVH-120	1			
2	0479-20090	ROLLER BEARING NJ307MC4	4			
3	4593-46010	ROTARY SHAFT, DRIVE/150N	1			
4	4593-46020	ROTARY SHAFT, DRIVEN/150N	1			
5	0802-00350	STOP RING S-35	2			
6	9514-05460	KEY 10X8X19 RR	1			
9	0403-06907	BEARING 6907C3	2			
11	4593-46230	PISTON ROD /MVH-150	1			
12	0255-08050	PIN 8X50	1		SX	
13	0425-06000	BEARING 6000ZZSG	2			
14	0802-00100	STOP RING S-10	1			
15	4554-35051	PISTON, 22.4D /MVH-200	1			
16	4550-10070	PACKING USH-22.4X30X5	1			
17	0801-00260	STOP RING R-26	1			
18	4594-59930	ECCENTRIC ROTATOR/MVH150N	4			
19	0091-20306	SOCKET HEAD BOLT 10X30T	4			
20	0602-02040	OIL SEAL SC-28458	1			
21	4583-37740	BEARING COVER /MVH-120	1			
22	0012-20820	BOLT 8X20 T	4			
23	0302-08200	SW M8	4			
24	0311-08160	PW M8	4			
25	9534-05580	SEAL CAP SC-458 /MVR-65W	1			
26	4582-14370	CYLINDER /MVH-120	1			
27	0012-20820	BOLT 8X20 T	4			
28	0302-08200	SW M8	4			
29	0311-08160	PW M8	4			
30	4603-47340	GEAR (DRIVE) /MVH-150	1			
31	4583-42590	GEAR (DRIVEN) /MVH-120, 150	1			
32	0012-20812	BOLT 8X12 T	1		SX	
33	9534-04600	COPPER PACKING 8X16X2	1		SX	
34	9540-10020	CONNECTOR PT, PF1/4	1			
35	4593-38460	PULLEY 83D W/FAN /MVH-150	1			GX200/EH25
35	4593-38450	PULLEY 80D W/FAN /MVH-150	1			DY23D/DS
35	4593-41310	PULLEY 90D W/FAN /MVH-150	1			L48
35	4593-38450	PULLEY 80D W/FAN /MVH-150	1			L48EU N2788-
36	9514-01920	KEY 7X7X30	1			
37	4594-59940	WASHER 9X(24-30)X7/MVH	1			
38	0012-20825	BOLT 8X25 T	1			
39	0302-08200	SW M8	1			
40	0012-21235	BOLT 12X35 T	2			
40	0012-21240	BOLT 12X40 T	2			
41	0012-21264	BOLT 12X120 T	6			
42	0302-12300	SW M12	8			
43	0311-12230	PW M12	8			
45	4592-14510	BELT COVER (LOWER) /MVH-150	1			
46	0015-20645	SOCKET HEAD BOLT 6X45 T	5			
48	9524-06180	SHIM 70-80-0.2T /MVH-120	1		SX	

MVH-100/120/150 (OLD TYPE /旧型)

4JO0

4-2. CONTROL / 操作關係

(MVH-100/120 ~ Serial No.L3080
 MVH-150 ~ Serial No.L2138)

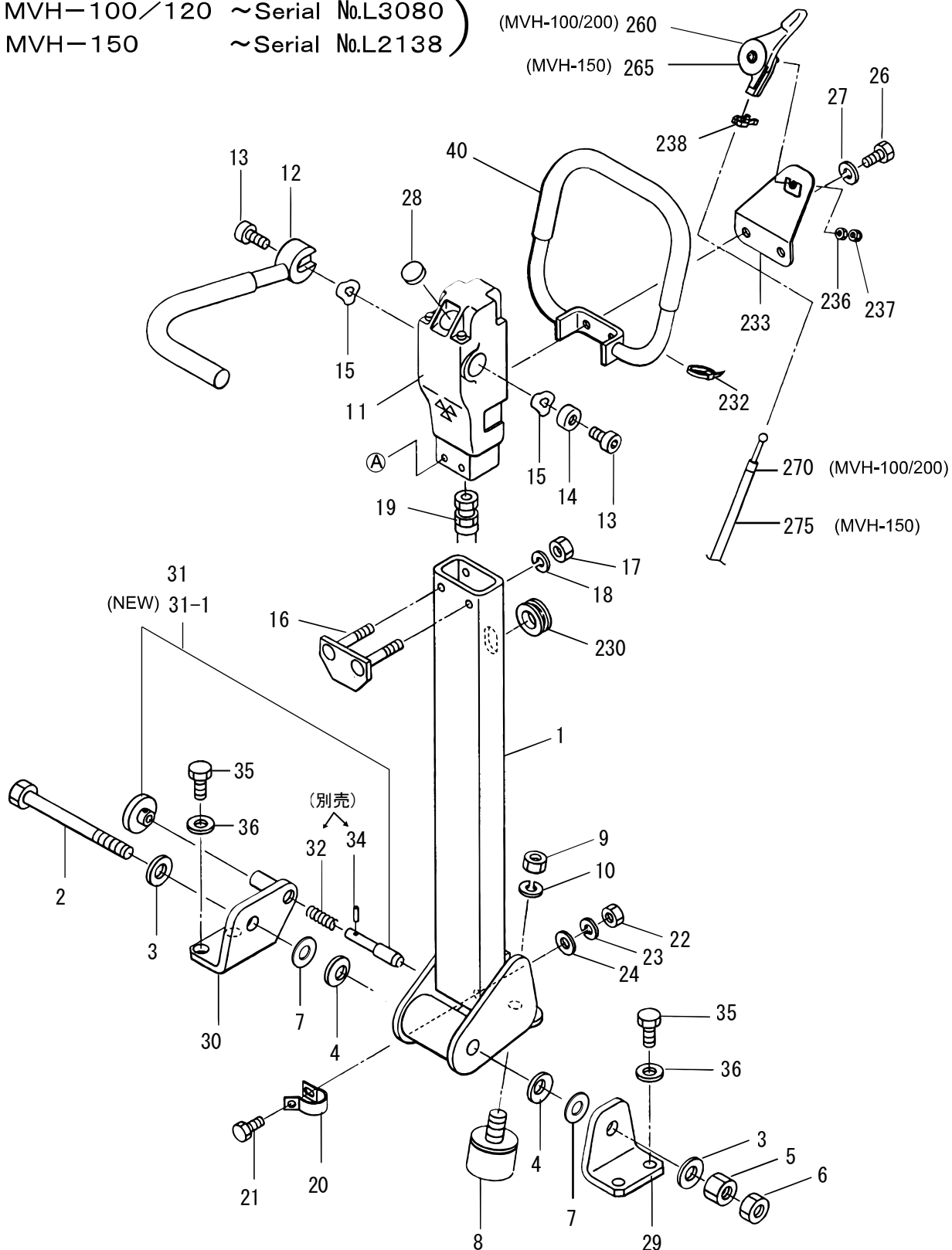

MVH-100/120/150 (OLD TYPE)

2009/12/18

4-2. CONTOL / 操作關係 (100/120 : №L 3030~L3080) (150 : ~№L2138)

** 4J0

**

REF NO.	PART NO.	PART NAME	Q' TY	MRK	MK2	REMARKS
1	4581-15181	HANDLE(G1387-)/MVH-120	1	DC		120/-L3080
1	4591-15450	HANDLE/MVH-150	1	DC		150/-L2138
2	0012-21669	BOLT 16X145 T	1		SX	
3	0311-16260	PW M16	2			
4	0322-16350	CONICAL SPRING WASHER M16	2			
5	0203-16130	NUT M16	1			
6	0204-16100	NUT M16, H=10	1			
7	4584-50660	WASHER 16.4-35-0.6/MVH120	2			
8	9390-10010	SHOCK ABSORBER, STOPPER45	1			
9	0203-10080	NUT M10	1			
10	0302-10250	SW M10	1			
11	4583-38000	PUMP AY / MVH-100/150	1	DC	!4583-38001	
11	4583-38001	PUMP AY /MVH-100/150	1		SX	
12	4583-37430	TRAVEL LEVER /MVH-120	1			MVH-100/120
12	4593-37960	TRAVEL LEVER/MVH-150	1		SX	MVH-150
13	0015-20820	SOCKET HEAD BOLT 8X20 T	2			
14	4584-51420	COLLAR /MVH-120	1			
15	0339-10030	WAVE WASHER 15.5X20X0.3	4			
16	4583-37480	PUMP HOLDER /MVH-120	1			
17	0227-10809	NYLON NUT M8	2			
18	0302-08200	SW M8	2			
19	4584-51350	OIL HOSE 870L /MVH-120	1			MVH-100/120
19	4594-52060	OIL HOSE 940L/MVH-150	1			MVH-150
20	9544-04230	CLAMP SA120-18	1			
21	0012-20625	BOLT 6X25 T	1			
22	0203-06050	NUT M6	1			
23	0302-06150	SW M6	1			
24	0311-06100	PW M6	1			
26	0012-20820	BOLT 8X20 T	2			
27	0302-08200	SW M8	2			
28	4584-51630	BREATHER CAP/ MVH-100/150	1			
29	4593-38030	HANDLE BRACKET(L)/MVH-150	1			
30	4593-38040	HANDLE BRACKET(R)/MVH-150	1			#6
30	4593-38041	HANDLE BRACKET(R)/MVH-150	1		SX	*6
31	4589-10020	STOPPER & GRIP SET	1		SX/SS!4589-1003	-L3029#6/100
31	4589-10020	STOPPER & GRIP SET	1		SX/SS!4589-1003	-L2077#6/150
31 -1	4589-10030	STOPPER & GRIP SET	1			L3030-*6/100
31 -1	4589-10030	STOPPER & GRIP SET	1			L2078-*6/150
32	4584-50880	SPRING 1.2-10-29 /MVH-120	1			
34	0254-02516	SPRING PIN 2.5X16	1			
35	0012-21230	BOLT 12X30 T	4			
36	0302-12300	SW M12	4			
40	4582-14560	HANDLE GRIP(JPN) /MVH-120	1			FOR JPN
40	4582-14400	HANDLE GRIP(EXP) /MVH-120	1			FOR EXP
230	9534-06280	GROMMET NG-79-0	1	DC		
232	5060-10070	CLAMP TC-150	1	DC		
233	4593-38470	THRITTLE HOLDER/MVH-150	1	DC		
236	0203-05040	NUT M5	1	DC		
237	0221-30504	CAP NUT M5	1			
238	3714-48300	CLIP (M)	1	DC		
260	9562-00050	THRITTLE LEVER AY E353216	1			GX160/EH17
265	9562-00040	THRITTLE LEVER ASSY S31	1			DY23D/DS
265	9562-00050	THRITTLE LEVER AY E353216	1			GX200/EH25
265	9562-00050	THRITTLE LEVER AY E353216	1			#4 L48-K1859
265	9562-00080	THRITTLE LEVER AY S41/150	1		!!9562-00050	*4 L48K1860-
270	9561-00035	THRITTLE WIRE 1210X1360	1			GX160 -L3080
270	9561-00036	THRITTLE WIRE 1430-1580	1			EH17 -L3080
275	9561-00035	THRITTLE WIRE 1210X1360	1			EH25 -L2138
275	9561-00036	THRITTLE WIRE 1430-1580	1			GX200/DY/L48

MVH-100A/120A/150A (NEW/新型 TYPE)

4-3. CONTROL/操作關係

4NA0

(MVH-100A/120A Serial No.L3081~)
(MVH-150A Serial No.L2139~)

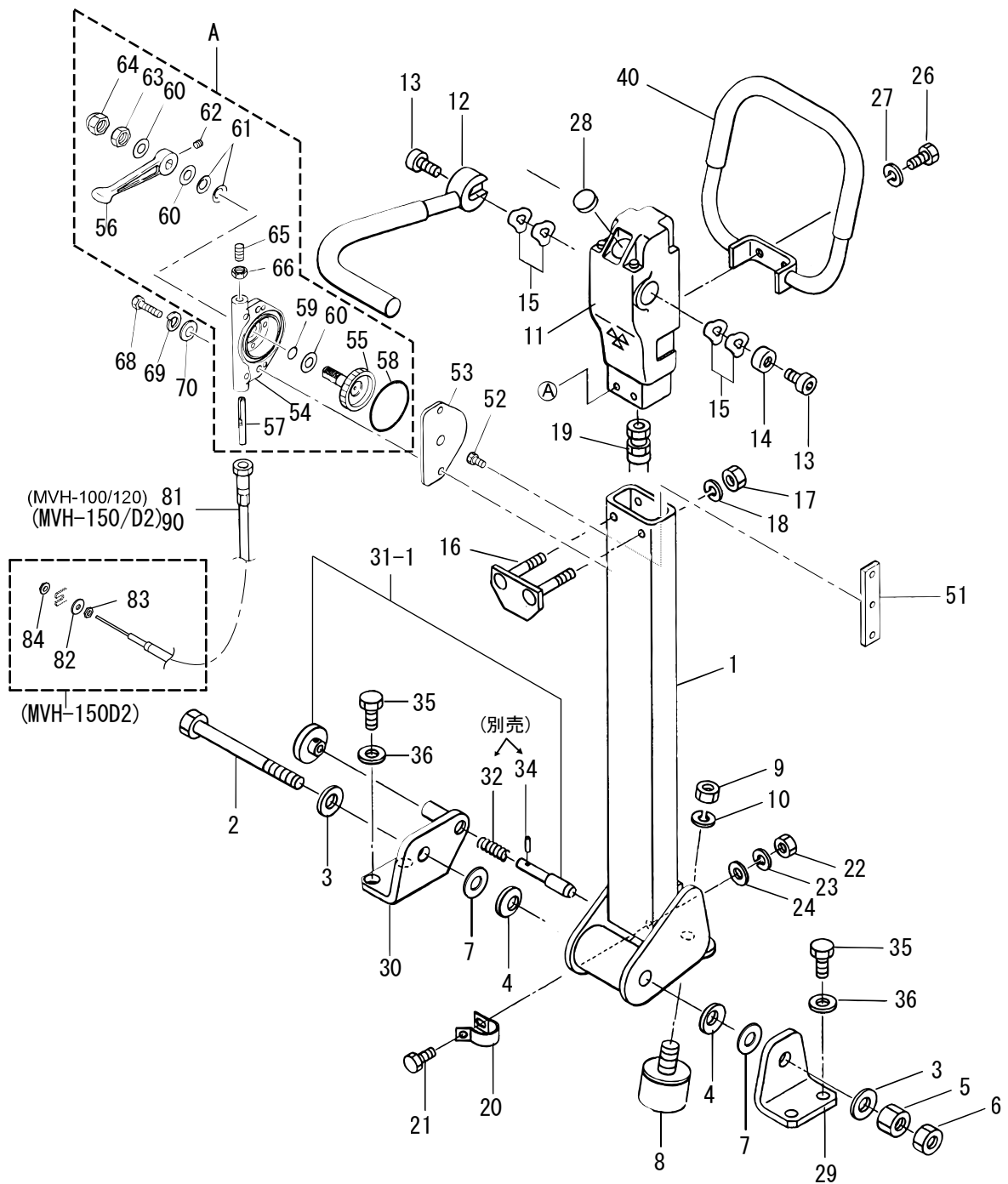

REF	NO.	PART NO.	PART NAME	Q' TY	MRK	MK2	REMARKS
	A	3629-10060	THROTTLE LEVER AY /MT-55	1			
1		4591-15451	HANDLE / MVH-100/120/150	1			120/L3081-
1		4591-15451	HANDLE / MVH-100/120/150	1			150/L2139-
2		0012-21669	BOLT 16X145 T	1		SX	
3		0311-16260	PW M16	2			
4		0322-16350	CONICAL SPRING WASHER M16	2	00		
5		0203-16130	NUT M16	1			
6		0204-16100	NUT M16, H=10	1			
7		4584-50660	WASHER 16.4-35-0.6/MVH120	2			
8		9390-10010	SHOCK ABSORBER, STOPPER45	1			
9		0203-10080	NUT M10	1			
10		0302-10250	SW M10	1			
11		4583-38001	PUMP AY /MVH-100/150	1		SX	
12		4583-37430	TRAVEL LEVER /MVH-120	1			MVH-100/120
12		4593-37960	TRAVEL LEVER/MVH-150	1		SX	MVH-150
13		0015-20820	SOCKET HEAD BOLT 8X20 T	2			
14		4584-51420	COLLAR /MVH-120	1			
15		0339-10030	WAVE WASHER 15.5X20X0.3	4			
16		4583-37480	PUMP HOLDER /MVH-120	1			
17		0227-10809	NYLON NUT M8	2			
18		0302-08200	SW M8	2			
19		4584-51350	OIL HOSE 870L /MVH-120	1			MVH-100/120
19		4594-52060	OIL HOSE 940L/MVH-150	1			MVH-150
20		9544-04230	CLAMP SA120-18	1			
21		0012-20625	BOLT 6X25 T	1			
22		0203-06050	NUT M6	1			
23		0302-06150	SW M6	1			
24		0311-06100	PW M6	1			
26		0012-20820	BOLT 8X20 T	2			
27		0302-08200	SW M8	2			
28		4584-51630	BREATHER CAP/ MVH-100/150	1			
29		4593-38030	HANDLE BRACKET (L)/MVH-150	1			
30		4593-38041	HANDLE BRACKET (R)/MVH-150	1		SX	
31 -1		4589-10030	STOPPER & GRIP SET	1			L3030- /100
31 -1		4589-10030	STOPPER & GRIP SET	1			L2078- /150
32		4584-50880	SPRING 1.2-10-29 /MVH-120	1			
34		0254-02516	SPRING PIN 2.5X16	1			
35		0012-21230	BOLT 12X30 T	4			
36		0302-12300	SW M12	4			
40		4582-14560	HANDLE GRIP (JPN) /MVH-120	1			FOR JPN
40		4582-14400	HANDLE GRIP (EXP) /MVH-120	1			FOR EXP
51		4634-55960	THROTTLE NUT /MVH-R60	1	AD		MVH-A
52		0015-20510	SOCKET HEAD BOLT 5X10 T	1	AD		MVH-A
53		4634-55950	SPACER, THROTTLE /MVH-R60	1	AD		MVH-A
54		3623-41550	THROTTLE BODY /MT-55	1	AD		MVH-A
55		3629-10090	THROTTLE, GEAR CP, W/BOLT	1	AD		MVH-A
56		3624-55630	THROTTLE LEVER /MT-55	1	AD		MVH-A
57		3624-55620	SLIDER /MT-55	1	AD		MVH-A
58		0501-00450	O-RING G-45	1	AD		MVH-A
59		0502-00100	O-RING P-10	1	AD		MVH-A
60		0311-10160	PW M10	3	AD		MVH-A
61		0321-10180	CONICAL SPRING WASHER M10	2			MVH-A
62		0962-06006	SOCKET HEAD SCREW 6X6	1	AD		MVH-A
63		0204-10060	NUT M10, H=6	1	AD		MVH-A
64		0221-31008	CAP NUT M10	1	AD		MVH-A
65		0962-08020	SOCKET HEAD SCREW 8X20	1	AD		MVH-A
66		0204-08050	NUT M8, H=5	1	AD		MVH-A
68		0012-20625	BOLT 6X25 T	2	AD		MVH-A
69		0302-06150	SW M6	2	AD		MVH-A
70		0311-06100	PW M6	2	AD		MVH-A
71		5110-10040	CLAMP TC-300	1	AD		MVH-A
81		9561-00041	THROTTLE WIRE 795-875/JP	1			GX160 L3081-
81		9561-00052	THROTTLE WIRE, /L48, 150	1			EH17 L3081-
82		160670-66350	WASHER/THROTTLE/MVH-150D2	1			150D2/L48V
83		26756-060002	LOCK NUT M 6 PLATED	1			150D2/L48V
84		26366-060002	NUT M 6	1			150D2/L48V
90		9561-00041	THROTTLE WIRE 795-875/JP	1			EH25 L2139-
90		9561-00050	THROTTLE WIRE845-1010/98D	1	OX		EH25 N2938-
90		9561-00047	THROTTLE WIRE 845-925/EXP	1			GX200 L2139-
90		9561-00052	THROTTLE WIRE, /L48, 150	1			DY23D/S, L48
90		9561-00059	THROTTLE WIRE/MVH-150D2	1			L48V6, DSB

MVH-100/120/150

4ID0

5. NAME PLATES / 銘板

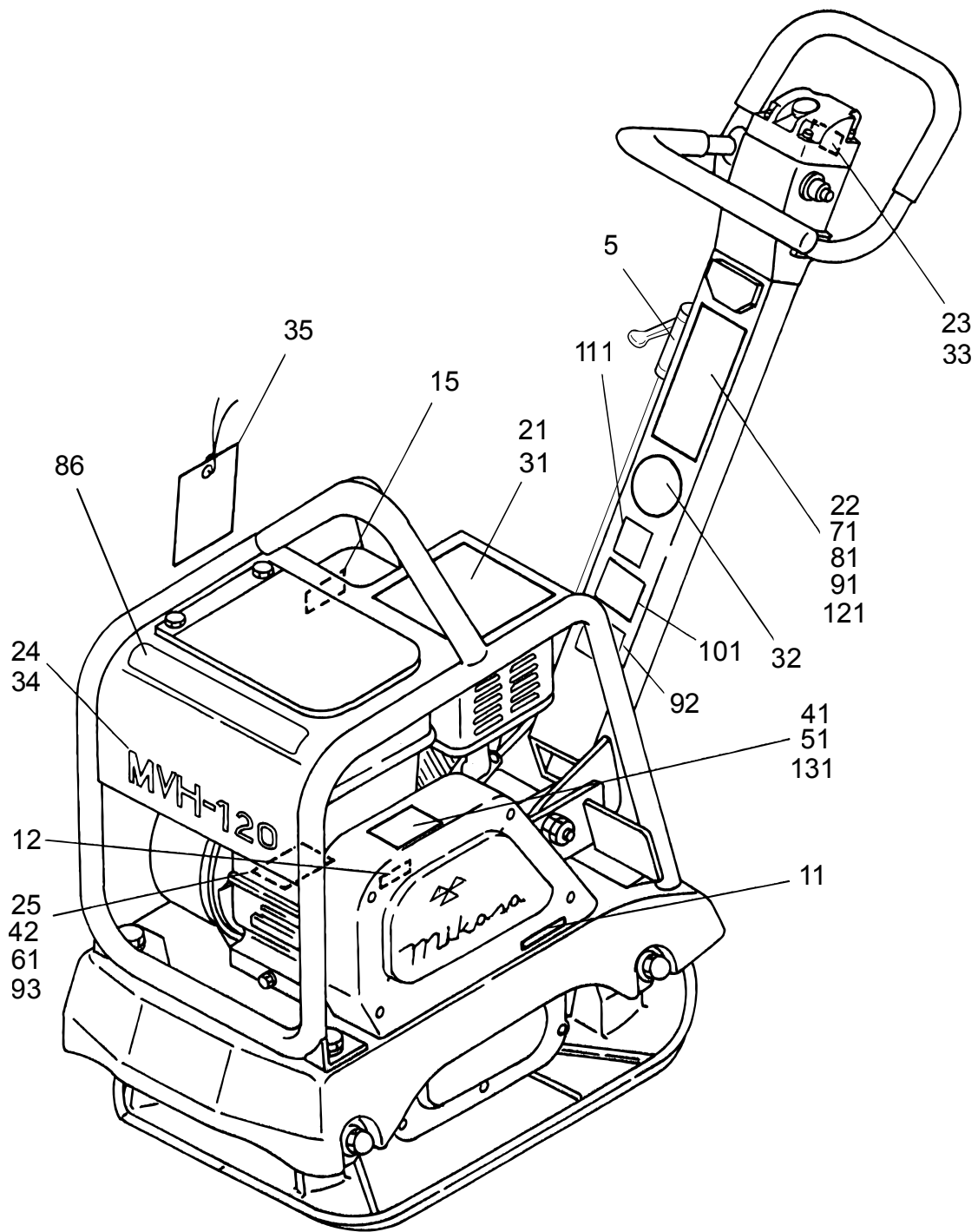

5. NAME PLATE / 銘板

** 4ID

**

REF NO.	PART NO.	PART NAME	Q' TY	MRK	MK2	REMARKS
5	9201-09981	DECAL, LEVER OPERATION	1			JPN.
5	9201-11300		1			150DSB (JPN)
11	9202-07420	DECAL, V-BELT RPF-3320	1			100/120/GX
11	9202-07670	DECAL, V-BELT RPF-3350	1			150/GX. EH. 48
11	9202-07680	DECAL, V-BELT RPF-3340	1			150/DY23
12	9202-01950	DECAL, OIL SAE 10W-30	1			
15	9201-08760	DECAL, THROTTLE (H-L)	1	DC		
21	9201-08790	DECAL, CAUTION	1			JPN/100, 150A
21	9202-10660	DECAL, CAUTION (ICON) /98D	1			JPN/150DSB
22	9201-08780	DECAL, CAUTION (MVH-120)	1			JAPAN
23	9201-08810	DECAL, OIL (SHELL TERAS 46)	1			JAPAN
24	9201-09210	DECAL, MODEL MVH-100	1			99/5-
24	9202-07660	DECAL, MODEL MVH-150	1			150/GX. EH. 48
25	9201-11250	PLATE, SERIAL NO. /MVH-100A	1			MVH-100A
25	9202-07850	PLATE, SERIAL NO. (MVH-150)	1			150GH (EXP)
25	9202-12620	PLATE, SERIAL NO. /MVH150GA	1			150GA (JPN)
25	9202-07001	PLATE, SERIAL NO. (MVH/CE)	1			150/DY
25	9202-10550	DECAL, IMER-MARK / MT	1			120GR
25	9202-12560	PLATE, SERIAL NO. /MVH150GR	1			150GR
25	9202-12570	PLATE, SERIAL NO. /MVH-150D	1			150D/5COUNT.
25	9202-12720		1			150DSB (JPN)
31	9202-07400	DECAL, DANGER-CAUTION	1			EXPORT
32	9202-03330	EAR PROTECTION LABEL	1			EXPORT
33	9202-07480	DECAL, SHELL TELLUS OIL 46	1			EXPORT
34	9202-07440	DECAL, MODEL/MVH-120	1			EXPORT
35	9202-00870	DECAL, WITHOUT ENGINE OIL	1			EXP. /R, Y
41	9202-01580	DECAL, MQ MARK 71X55	1			MQ
42	9202-11610	PLATE, SERIAL NO. /MVH/MQ	1			MQ
51	9202-01970	DECAL, PQ MARK	1	DC		PQ
61	9202-07450	PLATE, SERIAL NO. /MVH-120	1	DC		EXPORT/PQ
61	9202-10530	PLATE, SERIAL NO. / 72P	1	AD		5COUNT. /H
71	9202-07430	DECAL, CAUTION (MVH-120)	1			EXPORT
81	9202-07630	DECAL, CAUTION (ITALY)	1	DC		ITALY
86	9202-09530	DECAL, CAUTION/COMBINATION	1			L48. EXP
91	9202-07640	DECAL, CAUTION (SPAIN)	1	DC		SPAIN
92	9202-08510	DECAL, CAUTION / ES	1	DC		SPAIN
93	9202-06460	PLATE, SERIAL NO. (ES) 45X80	1	DC		CE
101	9202-07690	DECAL, CAUTION (MANUAL)	1			6COUNTRIES
111	9202-10100	DECAL, EC NOISE REQ. LWA108	1			EU 2002/2-
121	9202-09890	DECAL, CAUTION (ICON) /R60	1	AD		IMER 2002/9-
131	9202-07820	DECAL, IMER	1	AD		IMER 2002/9-

MVH-100/120/150

4LQ0

6. HAND POMP AY / ハンドポンプ AY

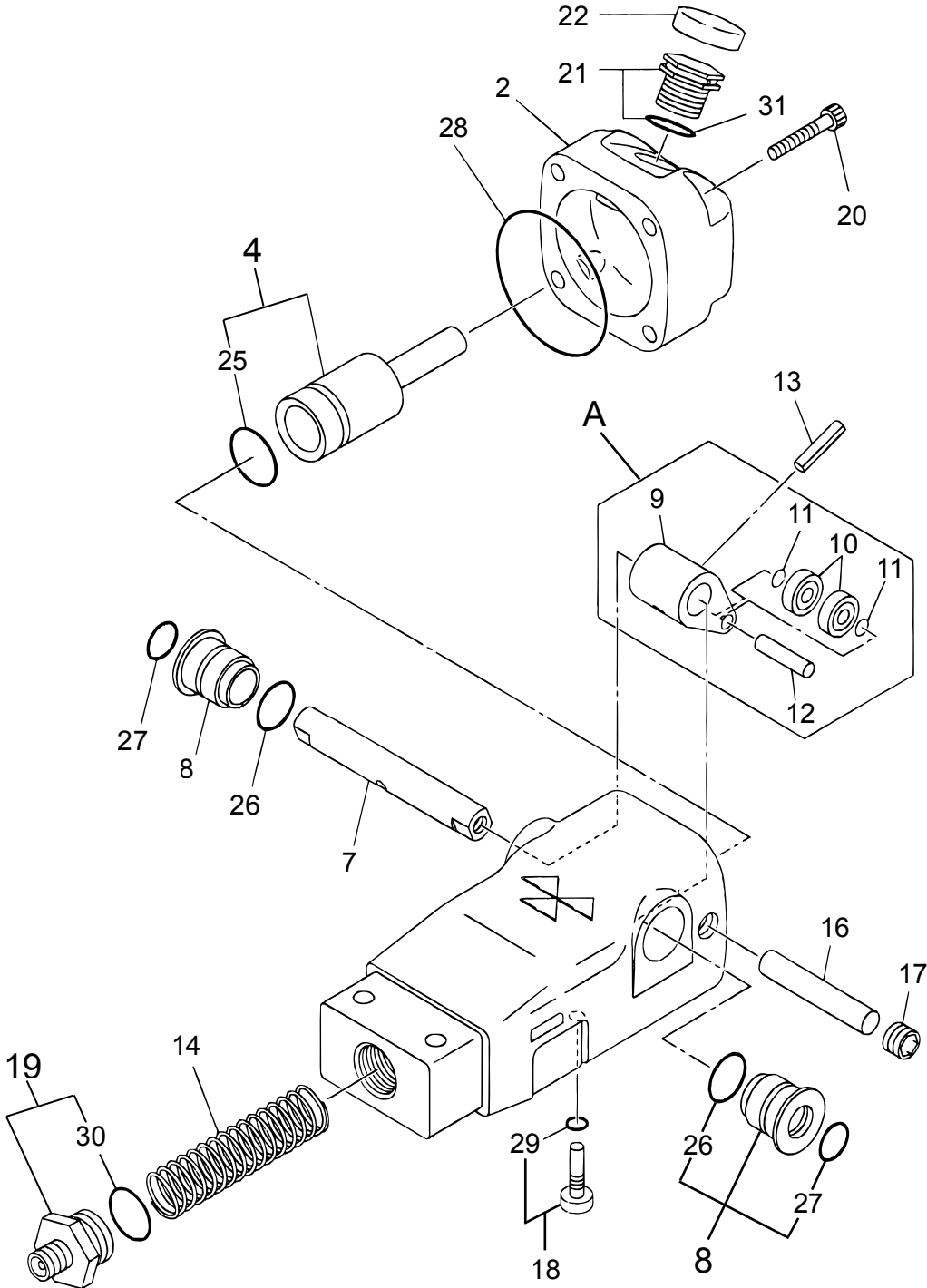

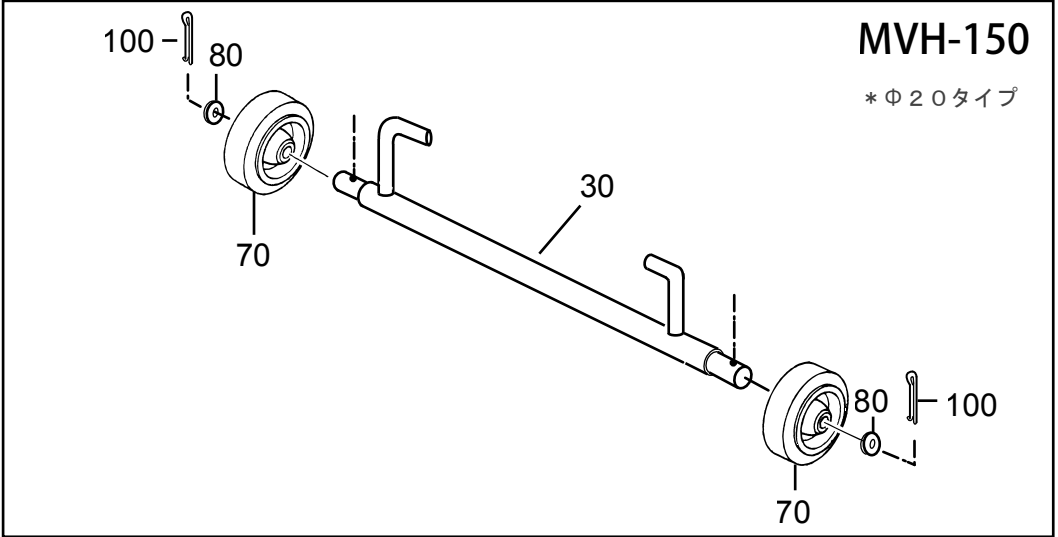
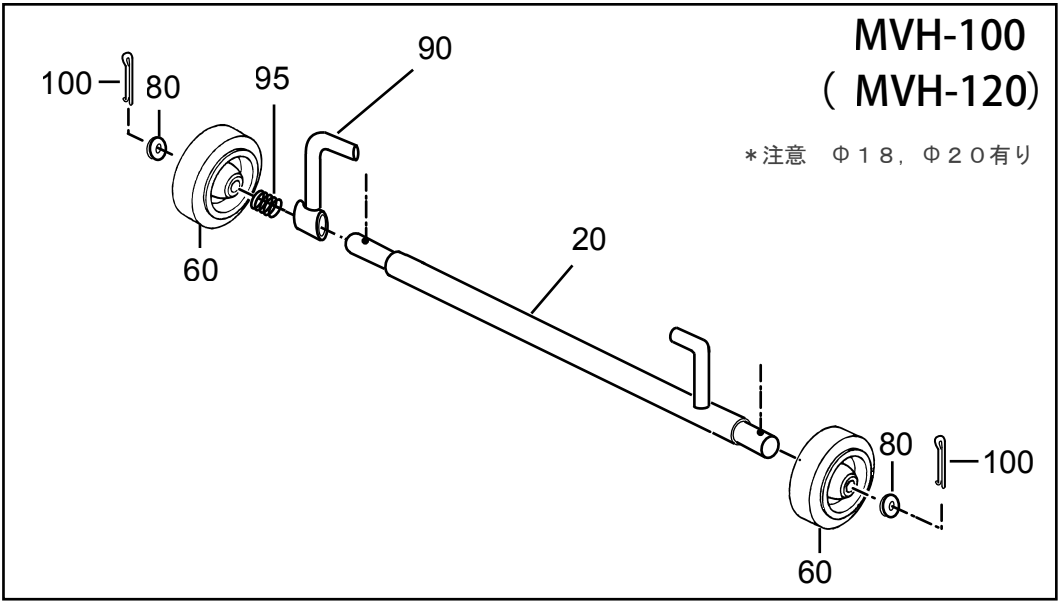
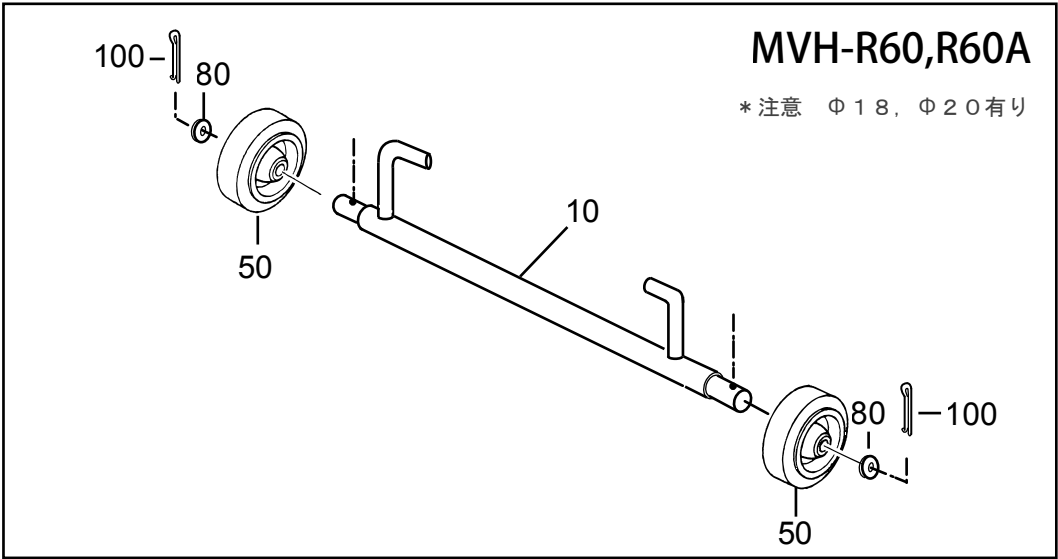



MIKASA SANGYO CO.,LTD.

HEAD OFFICE

NO. 4-3. 1-CHOME, SARUGAKU-CHO, CHIYODA-KU
TOKYO, JAPAN