



SPARE PARTS MANUAL

FLEXTOOL PLANETARY CONCRETE GRINDER FCG-450



Version 3.0 (October 2024)

FOR MORE INFORMATION VISIT flextool.com.au

HOW TO READ THIS SPARE PARTS MANUAL

The following section explains the different symbols and remarks used in this manual and how to interpret the information outlined in the following pages.

Section 1 – Diagram and parts list

- Item No : Used to reference the spare part in the diagram to the parts list.
- Product Code : Used to indicate the unique Flextool spare parts product code used when ordering parts.

Product code can be presented in the following ways:

- Number : Signifies the unique Flextool spare parts product code used when placing orders.
 - Blank : Used for parts pending formal part number assignment at the time of publication. Also denotes that the spare parts are not sold separately or are unavailable from Flextool.
 - See remarks : Indicates that the spare parts are part of an assembly, service kit or is part of a serial number range where a particular part is used. Please refer to remarks to find further information.
- Description : Used to provide a concise description of the spare part such as size, length, diameter, models, etc.
 - Qty : Indicates the quantity of part(s) required for the equipment. Please verify the required quantity when placing an order.
 - Remarks : Refers to additional information, including assembly kit, service kit and serial number range where particular part is used.
 - AS : Refers to the parts supplied with an assembly kit.
 - SK : Refers to the parts supplied with a service kit.
 - Serial number: Indicates the range of serial number where particular part is used.

Section 2 – Fast moving spare parts

FLEXTOOL PLANETARY CONCRETE GRINDER FCG-450

Description	Product Code
FLX BOLT SETS	NPS01732-UNIT
FLX RUBBER STOPPER	NPS02718-UNIT
FLX START SWITCH	NPS01771-UNIT
FLX STOP SWITCH	NPS01770-UNIT
FLX POWER INDICATOR	NPS01769-UNIT
FLX LATCH PIN	NPS02511-UNIT

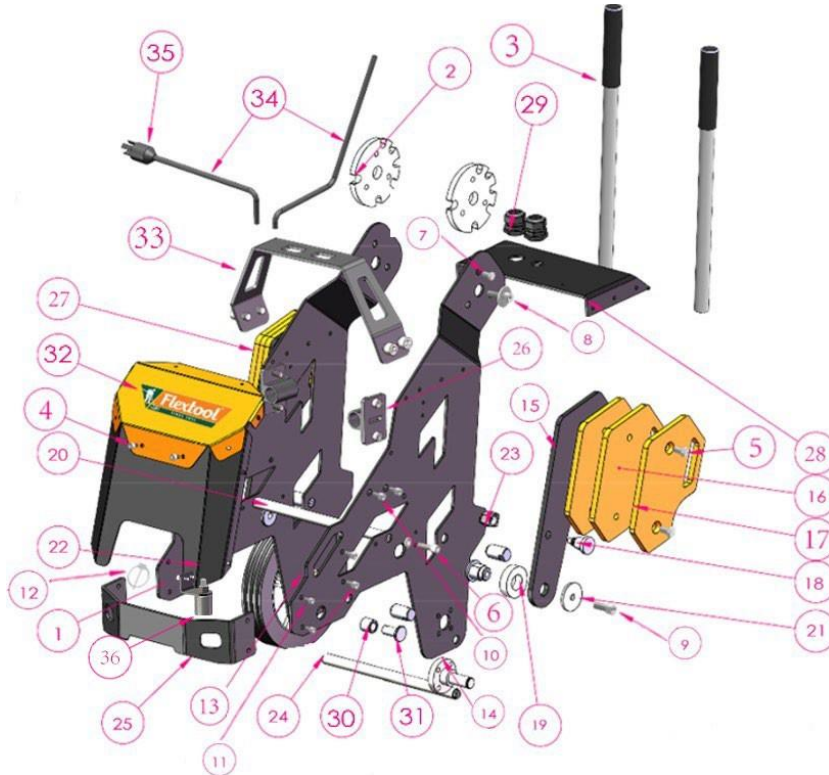

Frame (FCG-450)

Item No.	Product Code	Description	Qty	Remarks
1	NPS01714-UNIT	FLX RIGHT SIDE PANEL (SJI-23510-13-1)	1	
2	NPS01716-UNIT	FLX HANDLE ADJUSTING DISC (SJI-23510-14)	2	
3	NPS01739-UNIT	FLX LIFTING ROD (SJI-23510-125)	6	
4	NPS01751-UNIT	FLX HEX SOCKET HEAD CAP SCREW M6X20 (SJI-23510-301)	2	
5	NPS01745-UNIT	FLX HEX SCREW M12X30 (SJI-23510-302)	2	
6	NPS01746-UNIT	FLX HEX SOCKET HEAD CAP SCREW M8X20 (SJI-23510-303)	4	
7	NPS01740-UNIT	FLX HEX BOLT M12X20 (SJI-23510-6)	1	
8	NPS01741-UNIT	FLX HEX SOCKET HEAD CAP SCREW M8X25 (SJI-23510-8)	2	
	NPS01742-UNIT	FLX WASHER M8X25 (SJI-23510-8A)	2	
9	NPS01743-UNIT	FLX HEX SOCKET HEAD CAP SCREW M12X55 (SJI-23510-9)	4	
10	NPS01744-UNIT	FLX HEX SOCKET HEAD CAP SCREW M12X30 (SJI-23510-7)	1	
11	NPS01747-UNIT	FLX HEX SOCKET HEAD CAP SCREW M8X25 (SJI-23510-10)	2	
12	NPS01748-UNIT	FLX LOCK PIN (SJI-23510-120)	2	
13	NPS01715-UNIT	FLX LEFT SIDE PANEL (SJI-23510-13-2)	1	
14	NPS01717-UNIT	FLX AXLE (SJI-23510-15)	2	
15	NPS01718-UNIT	FLX COUNTERWEIGHT (SJI-23510-16)	4	
16	NPS01719-UNIT	FLX COUNTERWEIGHT RIGHT (SJI-23510-17-1)	2	
17	NPS01720-UNIT	FLX COUNTERWEIGHT LEFT (SJI-23510-17-2)	2	
18	NPS01721-UNIT	FLX STOPPER (SJI-23510-18)	1	
19	NPS01722-UNIT	FLX RETAINING WASHER (SJI-23510-19)	1	
20	NPS01723-UNIT	FLX COUNTERWEIGHT PIN (SJI-23510-20)	1	
21	NPS01725-UNIT	FLX LOCK WASHER (SJI-23510-21)	1	
22	NPS01726-UNIT	FLX FRONT PANEL (SJI-23510-22)	2	
23	NPS01727-UNIT	FLX COUNTERWEIGHT BLOCK (SJI-23510-23)	2	
24	NPS01724-UNIT	FLX RACK AXIS (SJI-23510-20-1)	2	
25	NPS01728-UNIT	FLX FRONT FRAME (SJI-23510-24)	1	
26	NPS01729-UNIT	FLX HANDLE HOLDER (SJI-23510-25)	1	
27	NPS01719-UNIT	FLX COUNTERWEIGHT RIGHT (SJI-23510-17-1)	2	
28	NPS01730-UNIT	FLX TOP COVER (SJI-23510-26)	1	
29	NPS01731-UNIT	FLX BELLOWS CONNECTOR (SJI-23510-27)	2	
30	NPS01732-UNIT	FLX BOLT SETS (SJI-23510-28)	2	
31	NPS01734-UNIT	FLX LATCH (SJI-23510-29)	6	
32	NPS01735-UNIT	FLX FRONT COVER ORANGE (SJI-23510-30)	2	
33	NPS01736-UNIT	FLX LIFT POLE (SJI-23510-31)	2	
34	NPS01889-UNIT	FLX SIGNAL CORD 1.5M (SJI-23510-400)	1	
35	NPS01737-UNIT	FLX PLUG (SJI-23510-33)	4	
36	NPS02718-UNIT	FLX RUBBER STOPPER (SJI-23510-600)	2	
	NPS02720-UNIT	FLX HEX BOLT M12X40 (SJI-23510-601)	2	
	NPS01924-UNIT	FLX LOCK NUT M12 (SJI-23510-146)	2	
	NPS01923-UNIT	FLX SPRING WASHER M12 (SJI-23510-145)	2	

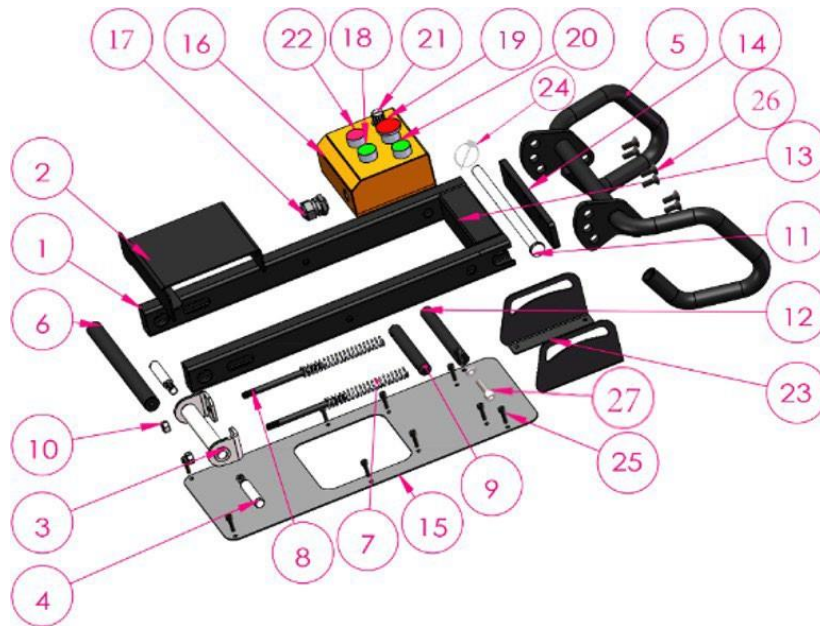

Handle (FCG-450)

Item No.	Product Code	Description	Qty	Remarks
1	NPS01752-UNIT	FLX CONTROL BOX RACK (SJI-23510-34)	1	
2	NPS01753-UNIT	FLX CONTROL BOX 450 COVER (SJI-23510-35)	1	
3	NPS01755-UNIT	FLX CONNECTING ROD (SJI-23510-36)	1	
4	NPS01756-UNIT	FLX SCREW M12 (SJI-23510-37)	2	
5	NPS01757-UNIT	FLX HANDLE (SJI-23510-38)	1	
6	NPS01758-UNIT	FLX HANDLE ROTATION AXIS (SJI-23510-39)	1	
7	NPS01759-UNIT	FLX SPRING (SJI-23510-40)	2	
8	NPS01760-UNIT	FLX SCREW-450 M10 (SJI-23510-41)	2	
9	NPS01761-UNIT	FLX HANDLEBAR (SJI-23510-42)	1	
10	NPS01762-UNIT	FLX NUT (SJI-23510-43)	2	
11	NPS01764-UNIT	FLX PIN (SJI-23510-44)	1	
12	NPS01765-UNIT	FLX HANDLE SUPPORT SHAFT (SJI-23510-45)	1	
13	NPS01766-UNIT	FLX HANDLE TUBE (SJI-23510-46)	1	
14	NPS01767-UNIT	FLX HANDLE TAILGATE (SJI-23510-47)	1	
15	NPS01768-UNIT	FLX SWITCH BOX BOTTOM PLATE (SJI-23510-48)	1	
16	NPS01690-UNIT	FLX SWITCH BOX (SJI-23510-49)	1	
17	NPS01731-UNIT	FLX BELLOWS CONNECTOR (SJI-23510-27)	1	
18	NPS01769-UNIT	FLX POWER INDICATOR (SJI-23510-51)	1	
19	NPS01770-UNIT	FLX STOP (SJI-23510-52)	1	
20	NPS01771-UNIT	FLX START INDICATOR LIGHT (SJI-23510-53)	1	
21	NPS01772-UNIT	FLX SPEED SWITCH STYLE (SJI-23510-54)	1	
22	NPS01773-UNIT	FLX DISPLAY (SJI-23510-55)	1	
23	NPS01774-UNIT	FLX SWITCH BOX BEZEL (SJI-23510-56)	1	
24	NPS01748-UNIT	FLX LATCH PIN (SJI-23510-120)	1	
25	NPS01775-UNIT	FLX HEX SOCKET HEAD SCREW M6X20 (SJI-23510-128)	10	
26	NPS01776-UNIT	FLX COUNTERSUNK HEAD SCREW M6X16 (SJI-23510-129)	6	
27	NPS01777-UNIT	FLX HEX SOCKET HEAD CAP SCREW M10X50 (SJI-23510-5)	2	

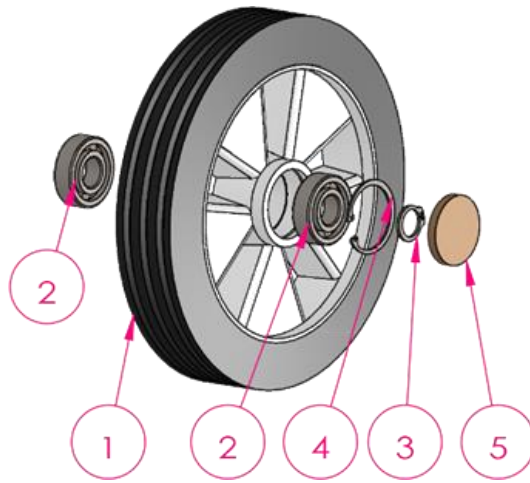

Wheel (FCG-450)

Item No.	Product Code	Description	Qty	Remarks
1	NPS01778-UNIT	FLX WHEEL (SJI-23510-57)	1	
2	NPS01779-UNIT	FLX ROLLING BEARINGS (SJI-23510-58)	2	
3	NPS01780-UNIT	FLX CIRCLIP B27.8M - 3DM1-20 (SJI-23510-59)	1	
4	NPS01781-UNIT	FLX CIRCLIP B27.7M - 3BM1-47 (SJI-23510-60)	1	
5	NPS01782-UNIT	FLX WHEELS COVER (SJI-23510-61)	1	

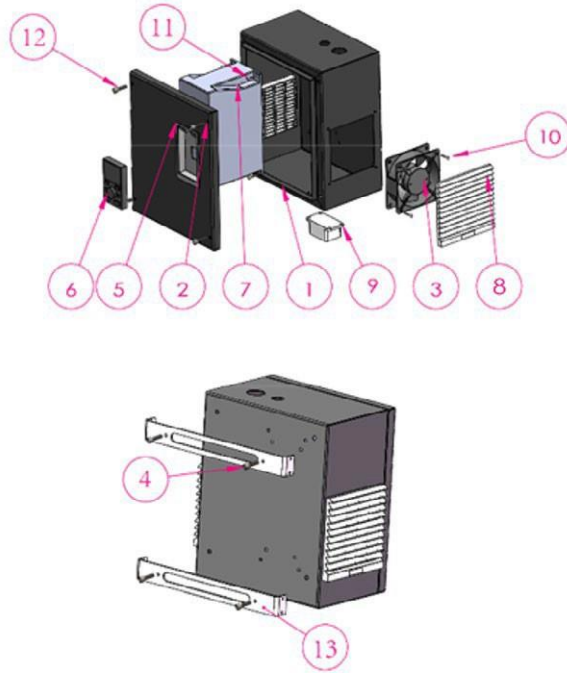

Electrical Box (FCG-450)

Item No.	Product Code	Description	Qty	Remarks
1	NPS01783-UNIT	FLX ELECTRICAL BOX (SJI-23510-62)	1	
2	NPS01823-UNIT	FLX ELECTRICAL BOX COVER (SJI-23510-63)	1	
3	NPS01824-UNIT	FLX FILTER (SJI-23510-64)	1	
4	NPS01833-UNIT	FLX HEX SOCKET HEAD SCREW M4X16 (SJI-23510-126)	4	
5	NPS01825-UNIT	FLX PANEL SUPPORT (SJI-23510-66)	1	
6	NPS01827-UNIT	FLX PANEL (SJI-23510-67)	1	
7	NPS01828-UNIT	FLX INVERTER 5.5KW (SJI-23510-68)	1	
8	NPS01829-UNIT	FLX LOUVER FILTER FAN (131X131) (SJI-23510-69)	2	
9	NPS01830-UNIT	FLX MOTOR POWER PLUG (SJI-23510-70)	1	
10	NPS01894-UNIT	FLX SCREW M4X16 (SJI-23510-130)	4	
11	NPS01831-UNIT	FLX HEX SOCKET HEAD SCREW M4X16 (SJI-23510-131)	4	
12	NPS01832-UNIT	FLX HEX SOCKET HEAD SCREW M6X30 (SJI-23510-304)	4	
13	NPS01834-UNIT	FLX ELECTRICAL BOX FIXING PARTS (SJI-23510-200)	2	

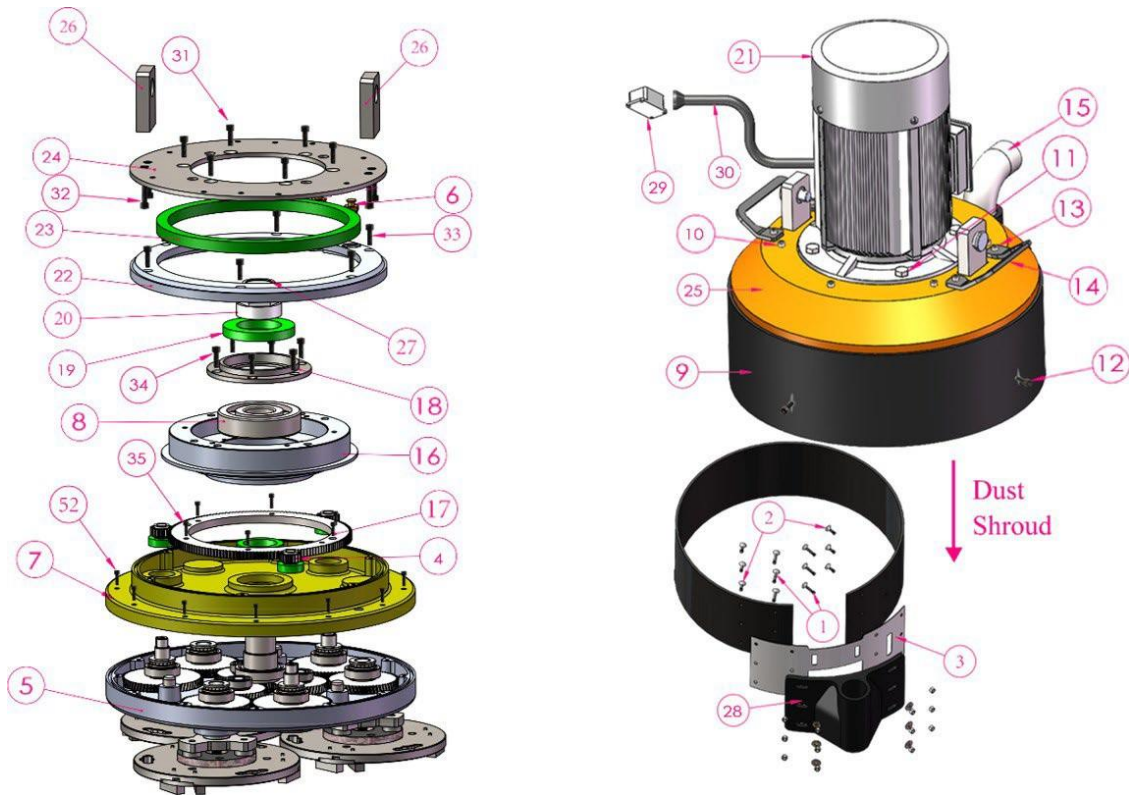

Motor & Gearbox Main Assembly (FCG-450)

Item No.	Product Code	Description	Qty	Remarks
1	NPS01832-UNIT	FLX HEX SOCKET HEAD SCREW M6X30 (SJI-23510-304)	6	
	NPS01901-UNIT	FLX SCREW WASHER+NUT M6X30 (SJI-23510-304A)	6	
2	NPS01902-UNIT	FLX HEX SOCKET HEAD SCREW M6X20 (SJI-23510-305)	6	
	NPS01904-UNIT	FLX SCREW WASHER+NUT M6X20 (SJI-23510-305A)	6	
3	NPS01905-UNIT	FLX SHROUD FIXED METAL SHEET (SJI-23510-306)	1	
4	NPS01972-UNIT	FLX SPUR GEAR (SJI-23510-73)	3	
5	NPS02038-UNIT	FLX BOX CAN (SJI-23510-88)	1	
6	NPS01968-UNIT	FLX AIR VALVE (SJI-23510-71)	2	
7	NPS01969-UNIT	FLX TRANSFER BOX COVER (SJI-23510-72)	1	
8	NPS02039-UNIT	FLX BEARING 6408 (SJI-23510-90)	1	
9	NPS01899-UNIT	FLX DUST SHROUD W SCREWS (SJI-23510-300)	1	
10	NPS02061-UNIT	FLX HEX SOCKET HEAD CAP SCREW M6X20 (SJI-23510-11)	10	
11	NPS02062-UNIT	FLX OUTER HEXAGONAL BOLTS M12X40 (SJI-23510-12)	4	
12	NPS02063-UNIT	FLX SHROUD SCREW SET (SJI-23510-121)	4	
13	NPS02064-UNIT	FLX HANDLE SCREW SET (SJI-23510-122)	4	
14	NPS02065-UNIT	FLX HANDLE (SJI-23510-123)	2	
15	NPS01900-UNIT	FLX SHROUD OUTLET (SJI-23510-124)	1	
16	NPS02032-UNIT	FLX CONNECTOR (SJI-23510-74)	1	
17	NPS02033-UNIT	FLX BIG SPUR GEAR (SJI-23510-75)	1	
18	NPS02034-UNIT	FLX GLAND (SJI-23510-76)	1	
19	NPS02035-UNIT	FLX OIL SEAL (SJI-23510-77)	1	
20	NPS02036-UNIT	FLX NUT (SJI-23510-87)	1	
21	NPS01895-UNIT	FLX MOTOR-2.2KW (SJI-23510-78)	1	
22	NPS02041-UNIT	FLX REVOLUTION COVER (SJI-23510-79)	1	
23	NPS01896-UNIT	FLX OIL SEAL 240-270-15 (SJI-23510-80)	1	
24	NPS02042-UNIT	FLX HOUSING MOUNTING PLATE (SJI-23510-82)	1	
25	NPS02043-UNIT	FLX SHELL (SJI-23510-83)	1	
26	NPS02044-UNIT	FLX CLAMP (SJI-23510-84)	2	
27	NPS02046-UNIT	FLX CONNECTOR (SJI-23510-86)	1	
28	NPS02045-UNIT	FLX SHROUD OUTLET CONNECTOR (SJI-23510-85)	3	
29	NPS01897-UNIT	FLX MOTOR PLUG (SJI-23510-133)	1	
30	NPS01898-UNIT	FLX MOTOR CABLE (SJI-23510-134)	1	

Motor Box (FCG-450) Continued

31	NPS02056-UNIT	FLX COUNTERSUNK HEAD SCREW M8X30 (SJI-23510-135)	6	
32	NPS02057-UNIT	FLX COUNTERSUNK HEAD SCREW M10X30 (SJI-23510-136)	4	
33	NPS02058-UNIT	FLX COUNTERSUNK HEAD SCREW M6X30 (SJI-23510-137)	6	
34	NPS02059-UNIT	FLX COUNTERSUNK HEAD SCREW M6X20 (SJI-23510-138)	6	
35	NPS02058-UNIT	FLX COUNTERSUNK HEAD SCREW M6X30 (SJI-23510-137)	6	
36	NPS02060-UNIT	FLX INNER HEXAGON SCREW M6X35 (SJI-23510-140)	12	

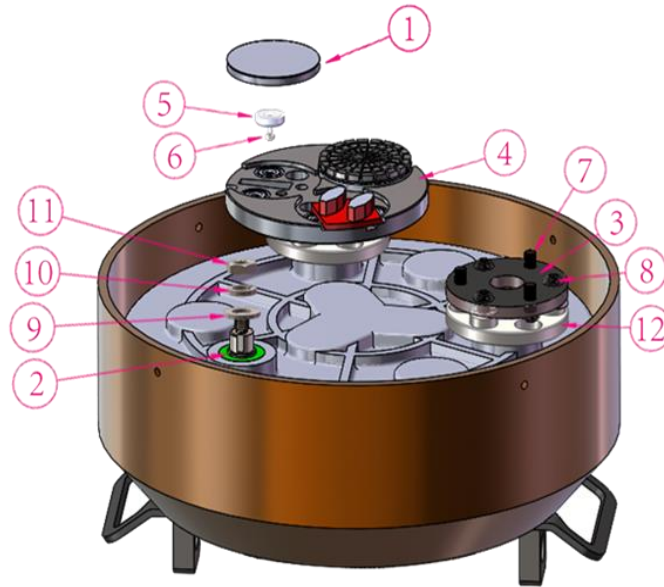

Plates (FCG-450)

Item No.	Product Code	Description	Qty	Remarks
1	NPS01907-UNIT	FLX RESIN PADS ADAPTERS (SJI-23510-112)	9	
2	NPS01908-UNIT	FLX OIL SEAL OF PLATES (SJI-23510-113)	6	
3	NPS01911-UNIT	FLX RUBBER (SJI-23510-114)	3	
4	NPS01913-UNIT	FLX PLATES (SJI-23510-115)	3	
5	NPS01914-UNIT	FLX BIG MAGNET (SJI-23510-116)	18	
6	NPS01915-UNIT	FLX SCREW & NUT FOR MAGNET M4X20 (SJI-23510-141)	18	
	NPS01916-UNIT	FLX WASHER M4 (SJI-23510-141A)	9	
7	NPS01917-UNIT	FLX BOLT M10X20 (SJI-23510-142)	9	
	NPS01919-UNIT	FLX WASHER M10 (SJI-23510-142A)	9	
8	NPS01920-UNIT	FLX BOLT M10X25 (SJI-23510-143)	9	
	NPS01921-UNIT	FLX WASHER M10 (SJI-23510-143A)	9	
9	NPS01922-UNIT	FLX FLAT WASHERS M12 (SJI-23510-144)	9	
10	NPS01923-UNIT	FLX SPRING WASHER M12 (SJI-23510-145)	9	
11	NPS01924-UNIT	FLX LOCK NUT M12 (SJI-23510-146)	9	
12	NPS02993-UNIT	FLX CONNECTING PLATE (SJI-23510-701)	3	

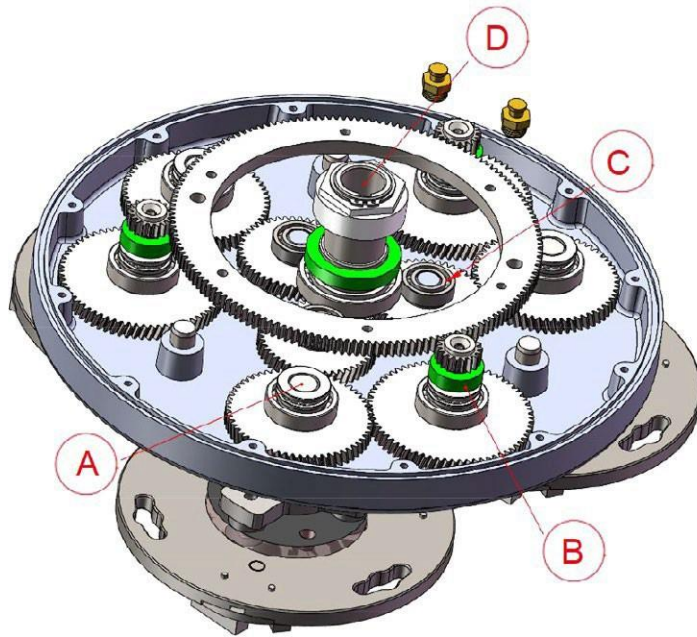

Gear Assembly (FCG-450)

Item No.	Product Code	Description	Qty	Remarks
A	NPS02067-UNIT	FLX GEAR ASSEMBLY A (SJI-23728-1)	3	
B	NPS02068-UNIT	FLX GEAR ASSEMBLY B (SJI-23728-2)	3	
C	NPS02069-UNIT	FLX GEAR ASSEMBLY C (SJI-23728-3)	3	
D	NPS02070-UNIT	FLX GEAR ASSEMBLY D (SJI-23728-4)	1	

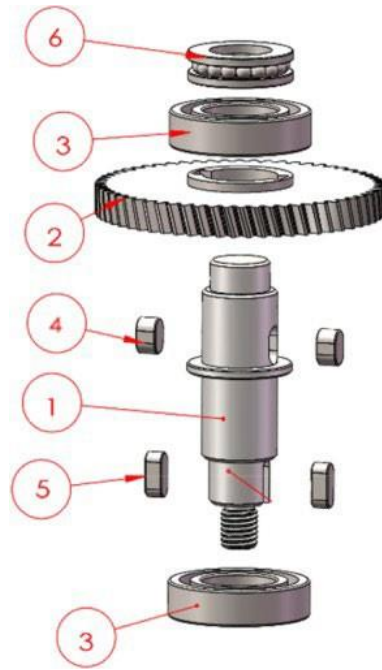

Gear A (FCG-450)

Item No.	Product Code	Description	Qty	Remarks
1	See Remarks	FLX OUTPUT SHAFT (SJI-23510-91)	1	Use AS-1
2	See Remarks	FLX HELICAL GEAR (SJI-23510-92)	1	Use AS-1
3	See Remarks	FLX ROLLING BEARINGS 6005 (SJI-23510-93)	2	Use AS-1
4	See Remarks	FLX KEY (SJI-23510-94)	2	Use AS-1
5	See Remarks	FLX KEY (SJI-23510-95)	2	Use AS-1
6	See Remarks	FLX ROLLING BEARINGS 51104 (SJI-23510-103)	1	Use AS-1

Gear A (FCG-450) Assembly / Service Kits

Item No.	Product Code	Description	Qty	Remarks
AS-1	NPS02067-UNIT	FLX GEAR ASSEMBLY A (SJI-23728-1)	1	Inc Items: 1-6

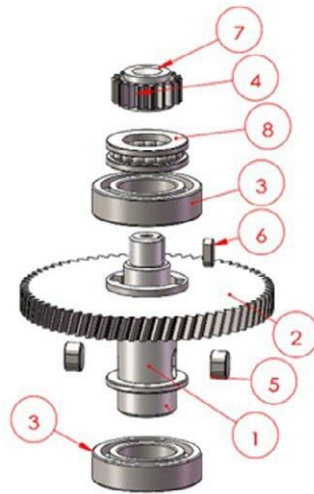

Gear B (FCG-450)

Item No.	Product Code	Description	Qty	Remarks
1	See Remarks	FLX OUTPUT SHAFT (SJI-23510-96)	1	USE AS-1
2	See Remarks	FLX HELICAL GEAR (SJI-23510-97)	1	USE AS-1
3	See Remarks	FLX ROLLING BEARINGS 6005 (SJI-23510-93)	2	USE AS-1
4	See Remarks	FLX SPUR GEAR (SJI-23510-99)	1	USE AS-1
5	See Remarks	FLX KEY (SJI-23510-94)	2	USE AS-1
6	See Remarks	FLX KEY (SJI-23510-101)	1	USE AS-1
7	See Remarks	FLX GASKET M6 (SJI-23510-102)	1	USE AS-1
8	See Remarks	FLX ROLLING BEARINGS 51104 (SJI-23510-103)	1	USE AS-1

Gear B (FCG-450) Assembly / Service Kits

Item No.	Product Code	Description	Qty	Remarks
AS-1	NPS02068-UNIT	FLX GEAR ASSEMBLY B (SJI-23728-2)	1	Inc Items: 1-8

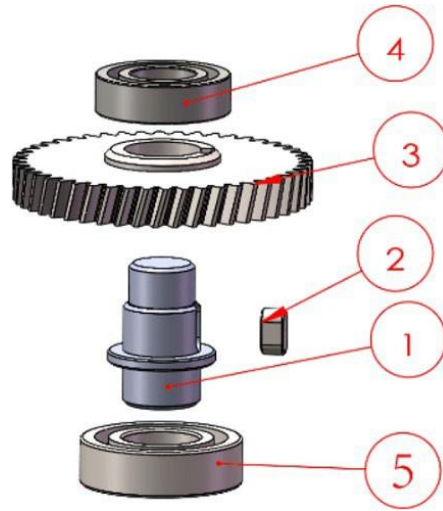

Gear Assembly C (FCG-450)

Item No.	Product Code	Description	Qty	Remarks
1	See Remarks	FLX INTERMEDIATE SHAFT (SJI-23510-104)	1	USE AS-1
2	See Remarks	FLX KEY (SJI-23510-95)	1	USE AS-1
3	See Remarks	FLX HELICAL GEAR (SJI-23510-106)	1	USE AS-1
4	See Remarks	FLX ROLLING BEARINGS 6003 (SJI-23510-107)	1	USE AS-1
5	See Remarks	FLX ROLLING BEARINGS 6004 (SJI-23510-108)	1	USE AS-1

Gear C (FCG-450) Assembly / Service Kits

Item No.	Product Code	Description	Qty	Remarks
AS-1	NPS02069-UNIT	FLX GEAR ASSEMBLY C (SJI-23728-3)	1	Inc Items: 1-5

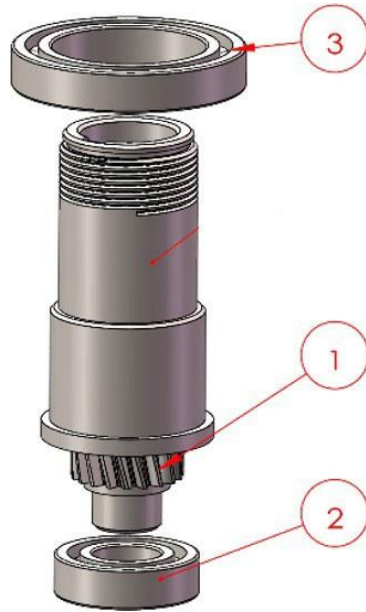

Gear D (FCG-450)

Item No.	Product Code	Description	Qty	Remarks
1	See Remarks	FLX HELICAL GEAR (SJI-23510-109)	1	USE AS-1
2	See Remarks	FLX ROLLING BEARINGS 6004 (SJI-23510-108)	1	USE AS-1
3	See Remarks	FLX ROLLING BEARINGS 61909 (SJI-23510-111)	1	USE AS-1

Gear D (FCG-450) Assembly / Service Kits

Item No.	Product Code	Description	Qty	Remarks
AS-1	NPS02070-UNIT	FLX GEAR ASSEMBLY D (SJI-23728-4)	1	Inc Items: 1-3



Flextool

1956 Dandenong Road, Clayton VIC 3168, Australia

Phone (AUS): 1300 353 986

flextool.com.au

ABN 80 069 961 968

This manual summarises our best knowledge of the product based on the information available at the time of publication. You should read this manual carefully and consider the information in the context of how the product will be used. Our responsibility for products sold is subject to our standard terms and conditions of sale.

DISCLAIMER:

Any advice, recommendation, information, assistance or service provided by us in this manual is given in good faith and is believed by us to be appropriate and reliable. However, any advice, recommendation, information, assistance or service provided by us is provided without liability or responsibility PROVIDED THAT the foregoing shall not exclude, limit, restrict or modify the right entitlements and remedies conferred upon any person or the liabilities imposed upon us by any condition or warranty implied by Commonwealth, State or Territory Act or ordinance void or prohibiting such exclusion limitation or modification. The product can be expected to perform as indicated in this manual so long as operation and operational procedures of the individual products are followed as recommended in this manual.

Design and technical specifications may be subject to changes.

© This publication is copyright. All rights are reserved. Flextool is a registered trade mark of Parchem Construction Supplies Pty Ltd.