

GENERAL PURPOSE ENGINE

**GX200UT
GX200RT
GX200UT2
GX200RT2**

PARTS CATALOGUE

6

FOREWORD INDEX

1

ENGINE GROUP

2

PART NUMBER INDEX

3

PART NAME INDEX

4

Instruction for use of parts catalogue

- **This parts catalogue was prepared based on the latest information available as of October 22, 2012.**
- See the parts catalogue news for any revision that is made after October 22, 2012.
- **Always specify the part number when ordering a part.**
- Check the model, type, serial numbers, color, maker, and the size as needed before ordering a part.
- Note that the illustrations (part drawings) can differ from the actual parts in shape. They are given just to help you to refer to the parts.
- **When modifications or additions to this parts catalogue are made, a revised edition will be issued at an appropriate time, with successively progressing revision numbers on the cover. We recommend obtaining such revisions in order to keep your parts catalogue up-to-date at all times. To check whether a parts catalogue revision has been issued, please contact your Honda distributor.**

Initial version issue date June 10, 2005
Honda Motor Co., Ltd.

CONTENTS

	Page	Address No.	
● Instruction for use of parts catalogue	1	B 1	1
● How to refer to the part information	2	B 2	
● Part catalogue structure	3	B 3	
● When the parts were revised	4	B 4	
● Abbreviations used in the parts catalogue	4	B 4	
● How to check the part block and serial numbers	5	B 5	
● Models, parts catalogue codes and applicable serial numbers	6	B 6	
● Features of each type	10	B10	
● Fuel hose, general purpose hoses and vinyl hose	19	C 3	
● Illustrated index	20	C 4	
● ENGINE GROUP	24	D 1	2
● PART NO. INDEX	98	I 1	3
● PART NAME INDEX	102	J 1	4

How to refer to the part information

1

A Reference with "Illustrated index"

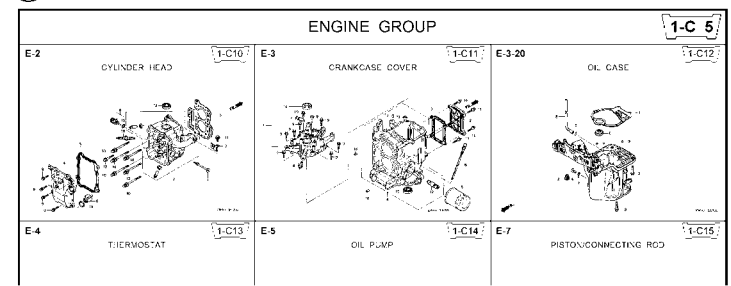

B Reference with "Part number index"

PART NO. INDEX

Part Number	Address	Page	Ref.	Part Number	Address	Page
06000				15212-ZW9-000	1-C14	3C
06316-ZW9-000	1-69	88	1	15220-ZW9-003	1-C14	3C
11000				15332-ZW9-000	1-E8	55
11300-ZW9-405	1-C11	27	1	15332-ZW9-A30	1-E11	5E
11300-ZW9-406	1-C11	27	1	15400-PFB-004	1-C11	27
11340-ZW9-000	1-C11	27	2	15422-ZW9-000	1-C14	3C
11342-ZW9-000	1-C11	27	3	15473-881-000	1-C14	3C
11381-ZW9-003	1-C12	28	1	15474-ZW9-000	1-C14	3C
				15611-921-000	1-C10	2E
				15655-ZW9-000	1-C11	27
12000				16000		
12000-ZW9-405ZA	1-C11	27	4	16010-ZV4-005	1-D4	3E
12155-ZV4-A00	1-C13	29	1	16011-ZV4-005	1-D4	3E
12166-ZW9-000	1-C10	26	1	16013-ZW9-003	1-D4	3E
12209-GB4-681	1-C16	32	1	16016-ZW9-003	1-D4	3E
12210-ZW9-405ZA	1-C10	26	2	16016-ZW9-721	1-D4	3E
12216-ZE2-300	1-E8	55	1	16023-ZW9-003	1-D4	3E
	1-E11	58	1	16024-ZV4-650	1-D4	3E
				16028-ZV4-650	1-D4	3E

C Reference with "Part name index"

PART NAME INDEX

Part name	Address	Page	Ref.
[A]			
ABSORBER , FUEL	1-E15	62	5
ARMATURE COMP.	1-D11	43	7
ARM COMP. , LINK JOINT	1-G6	85	18
ARM COMP. , SHIFT LINK	1-G6	85	14
ARM COMP. , TILT	1-F15	79	20
ARM , FUEL PUMP ROCKER	1-C16	32	4
ARM , REVERSE LOCK	1-F15	79	18
ARM , SHIFT LINK	1-F11	74	7
ARM , STOPPER	1-D1	33	12
ARM , THROTTLE REMOTE	1-F11	74	6
ARM , VALVE ROCKER	1-C16	32	3
[B]			
BAG , TOOL , 160MM	1-G5	84	10
BAND	1-G6	86	37
BAND B1 , WIRE	1-F6	69	1
BAND , CORD	1-F3	67	18
BAND , TUBE CLIP , 11MM	1-E15	63	20
BAND , TUBE CLIP , 12.5MM	1-E15	63	19

Address No. 1-C10

E-2 CYLINDER HEAD

Block No.

Ref No.

Ref. No.	Part No.	Description	Reqd. QTY						Serial No.	Parts catalogue code
			99D1	99D1	10D1	10D1	10B1	10B1		
1	12166-ZW9-000	STOPPER, ENGINE SIDE	2	2	2	2	2	2		
2	12210-ZW9-000ZA	HEAD COMP., CYLINDER	1	1	1	1	1	1		
3	12251-ZW9-003	GASKET, CYLINDER HEAD	1	1	1	1	1	1		
4	12310-ZW9-000	COVER COMP., HEAD	1	1	1	1	1	1		
5	12312-ZW9-000	PACKING, HEAD COVER	1	1	1	1	1	1		
6	15611-921-000	CAP, OIL (NO GAUGE)	1	1	1	1	1	1		
7	16617-ZW9-000	HOLDER, CABLE	1	1	1	1	1	1	SC,SG	
	16617-ZW9-010		1	1	1	1	1	1	1001801 LHC,LHD	
			1	1	1	1	1	1	1001801 LHC,LHD	
8	35673-ZV5-003	SENSOR ASSY., WATER	1	1	1	1	1	1		
9	90003-ZW9-000	BOLT, FLANGE, 6X22	4	4	4	4	4	4		
10	90007-ZW9-003	BOLT, FLANGE, 8X83	6	6	6	6	6	6		
11	90011-ZW9-000	BOLT, FLANGE, 6X14(CT200)	1	1	1	1	1	1		
12	90020-ZW9-000	BOLT, FLANGE, 8X40	2	2	2	2	2	2		
13	91202-KJ9-003	OIL SEAL, 20X32X6	1	1	1	1	1	1		
14	91301-805-000	O-RING, 26X2.7	1	1	1	1	1	1		
15	91307-PK2-005	O-RING, 9.5X1.5(HONDA KIKAKI)	1	1	1	1	1	1		
16	98059-55916	PLUG, SPARK (CR5EH-9)	2	2	2	2	2	2		
	98059-55926	PLUG, SPARK (U16FER9)	2	2	2	2	2	2		

Page No.

2000.09.20 E

Part catalogue structure

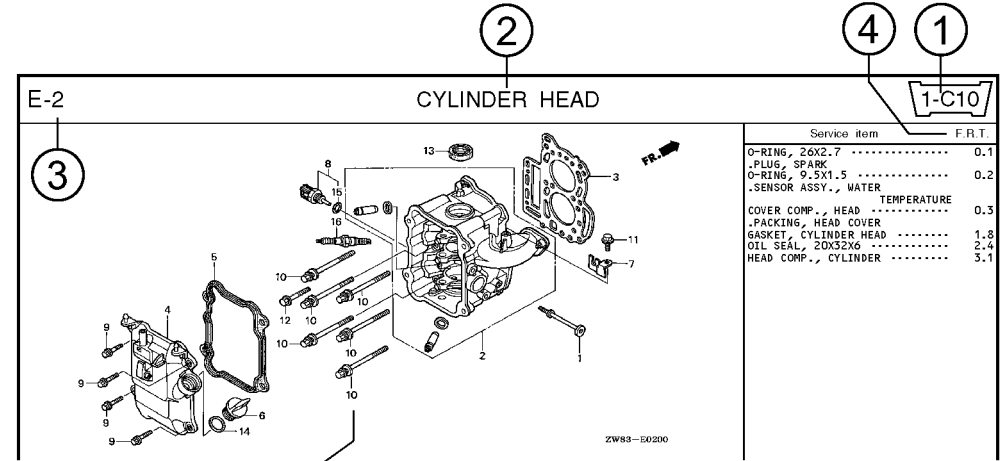

Ref. No.	Part No.	Description	Reqd. QTY						Serial No.	Parts catalogue code
			BF 9/9D1	BFP 9/9D1	BF 10D1	BFP 10D1	BF 10B1	BFP 10B1		
1	12166-zw9-000	STOPPER, ENGINE SIDE	2	2	2	2	2	2		
2	12210-zw9-000ZA	HEAD COMP., CYLINDER *NHS* DARK GRAY	1	1	1	1	1	1		
3	12251-zw9-003	GASKET, CYLINDER HEAD	1	1	1	1	1	1		
4	12310-zw9-000	COVER COMP., HEAD	1	1	1	1	1	1		
5	12312-zw9-000	PACKING, HEAD COVER	1	1	1	1	1	1		
6	15611-921-000	CAP, OIL (NO GAUGE)	1	1	1	1	1	1		
7	16617-zw9-000	HOLDER, CABLE	1	1	1	1	1	1	SC,SG	
	16617-zw9-010		1	1	1	1	1	1	1001800 LHC,LHD	

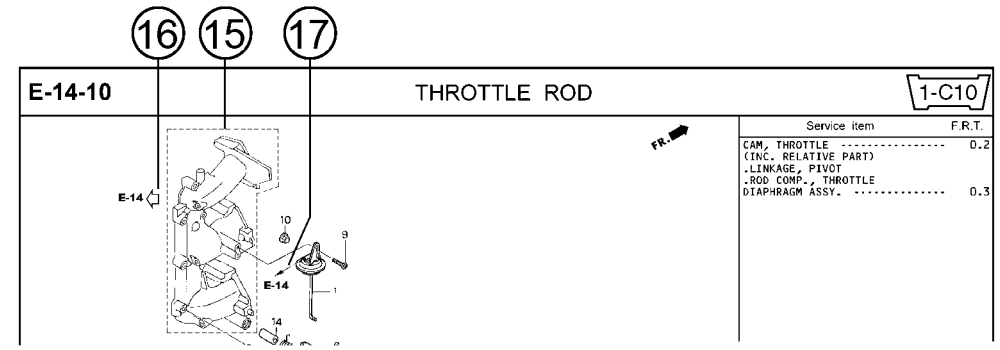

- ① **Address number**
 - Address No. is provided (in place of the page No.) to help you refer to the part with the part No. or part name.
- ② **Block title** ③ **Block number**
- ④ **Service item/Flat rate time**
- ⑤ **Reference number**
 - Title number marked with the parenthesis or parentheses indicates that it continues from the previous page.
- ⑥ **Part number** ⑦ **Honda color code**
- ⑧ **Description**
- ⑨ **Assemblies**
 - Sections framed with broken lines in the exploded view drawings are available as complete assemblies. (Their individual parts can also be obtained.)
- ⑩ **Color description**
- ⑪ **Note**
 - Notes are shown with the parentheses in the part name column.
- ⑫ **Required quantity**
 - Required QTY shown in the parenthesis or parentheses indicates the optional part.
 - Required QTY marked with "N" Indicates the optional part that should be selected as needed.
 - Required QTY indicates the number of the part used in the block.
- ⑬ **Serial number**
- ⑭ **Type**
 - When the type column is blank, it indicates that the part is applicable to all types.
 - As the type of the actual unit may differ from the "parts catalogue, type" please refer to "Models, types and applicable serial numbers" for confirmation.
- ⑮
 - Parts enclosed within a dotted line are covered in a different block.
- ⑯
 - A hollow arrow indicates the block No. for the parts enclosed within a dotted line .
- ⑰
 - A solid arrow indicates the block No. the part in question is connected to.

When the parts were revised

Abbreviations used in the parts catalogue

1



Be sure to check the serial number!!



Ref. No.	Part No.	Description	Reqd. QTY						Serial No.
			BF 99D1	BFP 9.9D1	BF 10D1	BFP 10D1	BF 10B1	BFP 10B1	
1	12166-ZW9-000	STOPPER, ENGINE SIDE	2	2	2	2	2	2	
2	12210-ZW9-000ZA	HEAD COMP., CYLINDER *NHS*	1	1	1	1	1	1	
3	12251-ZW9-003	GASKET, CYLINDER HEAD	1	1	1	1	1	1	
4	12310-ZW9-000	COVER COMP., HEAD	1	1	1	1	1	1	
5	12312-ZW9-000	PACKING, HEAD COVER	1	1	1	1	1	1	
6	15611-921-000	CAP, OIL (NO GAUGE)	1	1	1	1	1	1	
7	16617-ZW9-000	HOLDER, CABLE (###)	1	1	1	1	1	1	SC, SG LHC, LHD LHC, LHD
	16617-ZW9-010	1	1	1	1	1	1	

The number has been used from the initial model without revision.

When shown at the left side, it is applicable to the models of No.1001801 and the subsequent numbers.

When shown at the right side, it is applicable to the models up to No.1001800.

• The parts listed with "###" at the end of the parts name have limited supply period (parts not for sale).

• The following abbreviations are used in the parts name column.

- | | |
|--|-----------------------------|
| A Ampere | FR.Front |
| A.C. Alternating current | IN.Inlet |
| ASSY. Assembly | L (100L) .Link (100 Links) |
| AT. Automatic transmission | L.Left |
| C.D.I. Capacitive discharge ignition | MMMillimeter |
| COMP. ... Complete | MT.Manual Transmission |
| D.C. Direct current | P.T.O.Power take off |
| EX. Exhaust | R.Right |
| G.F.C.I ... Ground fault circuit interruptor | RR.Rear |
| HEX. Hexagonal | STD.Standard |
| H.S.T. Hydrostatic transmission | T (22T) ...Tooth (22 Teeth) |
| | VVolt |
| | WWatt |

How to check the part block and serial numbers

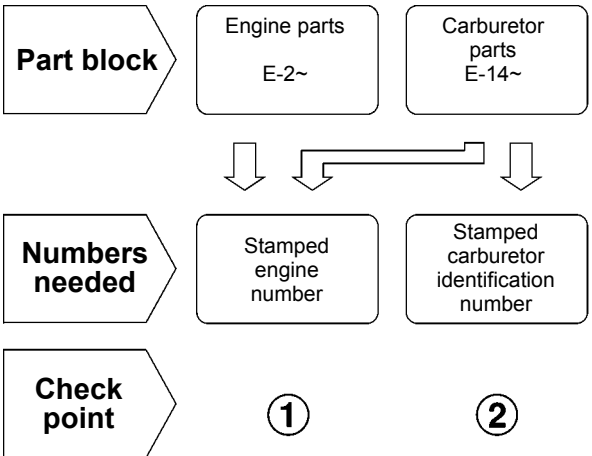

②-B
CARBURETOR
IDENTIFICATION NUMBER

②-A
CARBURETOR
IDENTIFICATION NUMBER

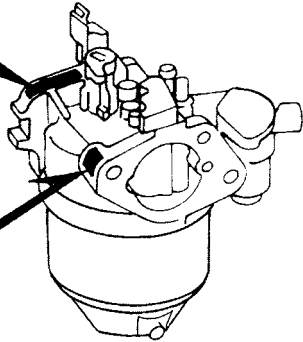

DZ4V-B

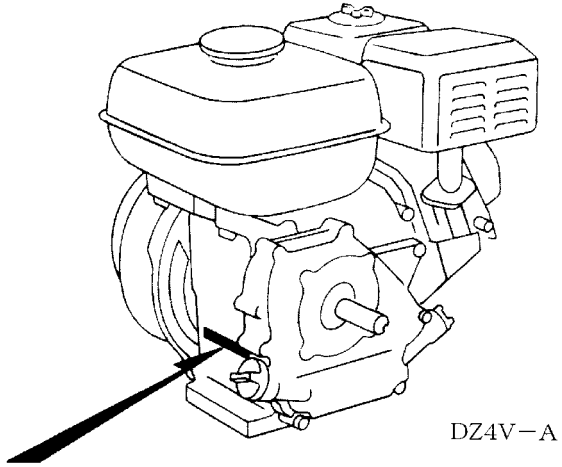

DZ4V-A

①
TYPE
ENGINE SERIAL NUMBER

Models, parts catalogue codes and applicable serial numbers

• Models, parts catalogue codes and applicable serial Nos. given in this parts catalogue can be identified as follows.

Model	Type	Parts catalogue type	Applicable engine serial No.	Applicable carburetor identification No.	Model	Type	Parts catalogue type	Applicable engine serial No.	Applicable carburetor identification No.
GX200UT	HX2	HX2	GCAHT-1000001~	BE64Y A	GX200UT	QXC9	QXC9	GCAHT-1000001~	BE59H A BE64F B
	HXU	HXU				QXD4	QXD4		
	LX2	LX2				QXD9	QXD9		
	LX4	LX4				QXE2	QXE2		
	LXAU	LXAU				QXE4	QXE4		
	PXU	PXU				QXE5	QXE5		
	QG2	QG2				QXE6	QXE6		
	QH26	QH26				QXU	QXU		
	QH4	QH4		RH2		RH2			
	QH4	QH4		RHQ4		RHQ4			
	QH4	QH4		RX4		RX4			
	QH4	QH4		RXU		RXU			
	QH4	QH4		SHQ2		SHQ2			
	QH4	QH4		SHQ4		SHQ4			
	QH4	QH4		SM12		SM12			
QH4	QH4	SMC2	SMC2						
QH4	QH4	SMC4	SMC4						
QH4	QH4			BE64Y A					

Model	Type	Parts catalogue type	Applicable engine serial No.	Applicable carburetor identification No.	Model	Type	Parts catalogue type	Applicable engine serial No.	Applicable carburetor identification No.
GX200UT	SMCR	SMCR	GCAHT-1000001~	BE64Y A	GX200UT	VGS9	VGS9	GCAHT-1000001~	BE64Y A
	SX4	SX4				BE74J A			
	SX7	SX7				BE74P A			
	SX9	SX9				BE74K B			
	SXE4	SXE4				BE74Q A			
	SXE5	SXE5				BE74J A			
	SXU	SXU				BE74P A			
	TX2	TX2				BE74K B			
	TX4	TX4				BE74Q A			
	TXD1	TXD1				BE74J A			
	TXDU	TXDU				BE74P A			
	TXU	TXU				BE64Y A			
	TXU1	TXU1							
	VEE9	VEE9							
	VGG2	VGG2		BE74Q A					
	VGGN	VGGN		BE64Z A					
VGS5	VGS5	BE64Y A							
GX200UT	VPM4	VPM4	GCAHT-1000001~	GX200UT	VPM4	VPM4	GCAHT-1000001~	GCAHT-1000001~	BE64Y A
	VPM8	VPM8			BE74K B				
	VPM9	VPM9			BE74Q A				
	VS17	VS17			BE74J A				
	VS19	VS19			BE74P A				
	VSD	VSD			BE74K B				
	VSD1	VSD1			BE74Q A				
	VSD2	VSD2			BE74J A				
	VSD7	VSD7			BE74P A				
	VSD9	VSD9			BE64Y A				
	VX2	VX2							
	VX4	VX4							
GX200RT	VXU	VXU	GCAHT-1000001~	GX200RT	RHG4	RHG4	GCAHT-1000001~	GCAHT-1000001~	BE64Y A
	VXU1	VXU1			RMG2	RMG2			

1

Model	Type	Parts catalogue type	Applicable engine serial No.	Applicable carburetor identification No.	Model	Type	Parts catalogue type	Applicable engine serial No.	Applicable carburetor identification No.		
GX200RT	SAR	SAR	GCAHT-1000001~	BE64Y A	GX200UT2	QXD9	QXD9	GCBTT-1000001~	BE59L A		
	SWG4	SWG4				QXE2	QXE2				
GX200UT2	HX2	HX2	GCBTT-1000001~	BE59L A		QXE4	QXE4				
	LX4	LX4				QXE5	QXE5				
	LXAU	LXAU				RH2	RH2				
	PXU	PXU				RHQ4	RHQ4				
	QG2	QG2				RX4	RX4				
	QH26	QH26				RXU	RXU				
	QHQ4	QHQ4				SAR	SAR				
	QMP4	QMP4		SHQ4		SHQ4					
	QX2	QX2		SM12		SM12					
	QX4	QX4		SM14		SM14					
	QX9	QX9		SM24		SM24					
	QXAG	QXAG		SMC4		SMC4					
	QXB2	QXB2		SMCR		SMCR					
QXC9	QXC9	SX4	SX4								
QXD4	QXD4	SX9	SX9								
				BE59S A							
				BE59L A							
				BE59R A							
				BE59L A							

Model	Type	Parts catalogue type	Applicable engine serial No.	Applicable carburetor identification No.
GX200UT2	SXE5	SXE5	GCBTT-1000001~	BE59L A
	SXU	SXU		BE59R A
	SXW9	SXW9		BE59L A
	TX2	TX2		
	TXD1	TXD1		
	TXDU	TXDU		
	VGS5	VGS5		
	VSD9	VSD9		
	VXU	VXU		
	VXU1	VXU1		
GX200RT2	RDG4	RDG4	GCBTT-1000001~	BE59L A
	RHG4	RHG4		
	RMG2	RMG2		
	SWG4	SWG4		BE74V A
	VEE9	VEE9		BE74Z A
	VENN	VENN		BE59P A
	VGGN	VGGN		

Model	Type	Parts catalogue type	Applicable engine serial No.	Applicable carburetor identification No.
GX200RT2	VPM4	VPM4	GCBTT-1000001~	BE74Z A
	VS19	VS19		BE74V A

* Of carburetor identification numbers, only the portions underlined in the example below are used for registration.

BE 64Y A KC ㊦
 (A) (B)

Features of each type

• See the following table for the features of each type. (Items in brackets are optional)

Specifications		Model	GX200UT														
		Type	HX2	HXU	LX2	LX4	LXAU	PXU	QG2	QH26	QH4	QH4	QHQ4	QMP4	QX2	QX26	QX4
Crankshaft	20 mm Ø Spline				●	●	●										
	21 mm Ø Spline	●	●														
	19.05 mm Ø Straight								●	●	●	●	●	●	●	●	●
	20 mm Ø Straight																
	3/4" Thread						●										
	5/8" Thread																
	3/16" Tapered																
	1/5" Tapered																
Engine stop switch			●	●	●	●	●	●	●	●		●		●	●	●	
Engine stop switch (~1240212)																	
Air cleaner	Dual		●	●	●	●	●	●	●	●		●		●	●	●	
	Standard																
	Oil bath												●				
	Cyclone										●						
Fuel tank			●	●	●	●	●	●	●	●	●	●	●	●	●	●	●
Starter motor											●						
Control box											●						
Reduction			●	●	●	●	●										
Muffler cover						(●)						(●)	(●)				(●)

Specifications		Model	GX200UT													
		Type	QX7	QX9	QXB2	QXC9	QXD4	QXD9	QXE2	QXE4	QXE5	QXE6	QXU	RH2	RHQ4	RX4
Crankshaft	20 mm Ø Spline															
	21 mm Ø Spline															
	19.05 mm Ø Straight	●	●	●	●	●	●	●	●	●	●	●				
	20 mm Ø Straight												●	●	●	
	3/4" Thread															
	5/8" Thread															
	3/16" Tapered															
	1/5" Tapered															
Engine stop switch		●	●		●	●	●					●	●	●	●	
Engine stop switch (~1240212)				●												
Air cleaner	Dual	●	●	●		●	●	●	●	●	●	●	●	●	●	●
	Standard															
	Oil bath															
	Cyclone				●											
Fuel tank		●	●	●	●	●	●	●	●	●	●	●	●	●	●	●
Starter motor								●	●	●	●					
Control box								●	●	●	●					
Reduction													●	●	●	
Muffler cover		(●)	(●)			(●)	(●)		(●)	(●)				(●)	(●)	

Specifications		Model	GX200UT													
		Type	RXU	SHQ2	SHQ4	SM12	SMC2	SMC4	SMCR	SX4	SX7	SX9	SXE4	SXE5	SXU	TX2
Crankshaft	20 mm Ø Spline															
	21 mm Ø Spline															
	19.05 mm Ø Straight															
	20 mm Ø Straight	●	●	●	●	●	●	●	●	●	●	●	●	●		
	3/4" Thread															
	5/8" Thread															●
	3/16" Tapered															
	1/5" Tapered															
Engine stop switch		●	●	●	●	●	●	●	●	●	●			●	●	
Engine stop switch (~1240212)																
Air cleaner	Dual	●	●	●	●	●	●	●	●	●	●	●	●	●	●	●
	Standard															
	Oil bath															
	Cyclone															
Fuel tank		●	●	●	●	●	●	●	●	●	●	●	●	●	●	●
Starter motor												●	●			
Control box												●	●			
Reduction		●														
Muffler cover			(●)	(●)		(●)	(●)	(●)	(●)	(●)	(●)	(●)	(●)			

Specifications		Model	GX200UT													
		Type	TX4	TXD1	TXDU	TXU	TXU1	VEE9	VGG2	VGGN	VGS5	VGS9	VPM4	VPM8	VPM9	VS17
Crankshaft	20 mm Ø Spline															
	21 mm Ø Spline															
	19.05 mm Ø Straight															
	20 mm Ø Straight															
	3/4" Thread															
	5/8" Thread	●	●	●	●	●										
	3/16" Tapered						●	●	●	●	●	●	●	●	●	●
	1/5" Tapered															
Engine stop switch		●		●	●			●	●	●	●	●	●	●	●	●
Engine stop switch (~1240212)																
Air cleaner	Dual	●	●	●	●	●		●	●	●	●					
	Standard						●					●	●	●	●	
	Oil bath															
	Cyclone															
Fuel tank		●	●	●	●	●				●	●					
Starter motor			●			●	●									
Control box			●			●										
Reduction																
Muffler cover		(●)								(●)	(●)					

Specifications		Model	GX200UT								GX200RT					
		Type	VS19	VSD	VSD1	VSD2	VSD7	VSD9	VX2	VX4	VXU	VXU1	RHG4	RMG2	SAR	SWG4
Crankshaft	20 mm Ø Spline															
	21 mm Ø Spline															
	19.05 mm Ø Straight															
	20 mm Ø Straight											●	●	●	●	
	3/4" Thread															
	5/8" Thread															
	3/16" Tapered	●	●	●	●	●	●	●	●	●	●					
	1/5" Tapered															
Engine stop switch		●	●	●	●	●	●	●	●	●	●	●	●	●		
Engine stop switch (~1240212)																
Air cleaner	Dual		●			●	●	●	●	●	●	●	●	●	●	●
	Standard	●		●	●											
	Oil bath															
	Cyclone															
Fuel tank			●			●	●	●	●	●	●				●	
Starter motor																●
Control box																
Reduction												●	●			
Muffler cover			(●)	(●)	(●)	(●)	(●)		(●)			(●)				

Specifications		Model	GX200UT2													
		Type	HX2	LX4	LXAU	PXU	QG2	QH26	QH4	QMP4	QX2	QX4	QX9	QXAG	QXB2	QXC9
Crankshaft	20 mm Ø Spline		●	●												
	21 mm Ø Spline	●														
	19.05 mm Ø Straight					●	●	●	●	●	●	●	●	●	●	●
	20 mm Ø Straight															
	3/4" Thread				●											
	5/8" Thread															
	3/16" Tapered															
	1/5" Tapered															
Engine stop switch		●	●	●	●	●	●	●		●	●	●	●			●
Engine stop switch (~1240212)																
Air cleaner	Dual	●	●	●	●	●	●	●		●	●	●	●	●		
	Standard															
	Oil bath								●							
	Cyclone															●
Fuel tank		●	●	●	●	●	●	●	●	●	●	●	●	●	●	●
Starter motor																
Control box																
Reduction		●	●	●												
Muffler cover			(●)					(●)	(●)		(●)	(●)				

1

Specifications		Model	GX200UT2													
		Type	QXD4	QXD9	QXE2	QXE4	QXE5	RH2	RHQ4	RX4	RXU	SAR	SHQ4	SM12	SM14	SM24
Crankshaft	20 mm Ø Spline															
	21 mm Ø Spline															
	19.05 mm Ø Straight	●	●	●	●	●										
	20 mm Ø Straight						●	●	●	●	●	●	●	●	●	●
	3/4" Thread															
	5/8" Thread															
	3/16" Tapered															
	1/5" Tapered															
Engine stop switch		●	●				●	●	●	●	●	●	●	●	●	
Engine stop switch (~1240212)																
Air cleaner	Dual	●	●	●	●	●	●	●	●	●	●	●	●	●	●	●
	Standard															
	Oil bath															
	Cyclone															
Fuel tank		●	●	●	●	●	●	●	●	●	●	●	●	●	●	●
Starter motor				●	●	●										
Control box				●	●	●										
Reduction							●	●	●	●						
Muffler cover		(●)	(●)		(●)	(●)		(●)	(●)			(●)				(●)

Specifications		Model	GX200UT2													
		Type	SMC4	SMCR	SX4	SX9	SXE5	SXU	SXW9	TX2	TXD1	TXDU	VGS5	VSD9	VXU	VXU1
Crankshaft	20 mm Ø Spline															
	21 mm Ø Spline															
	19.05 mm Ø Straight															
	20 mm Ø Straight	●	●	●	●	●	●	●								
	3/4" Thread															
	5/8" Thread									●	●	●				
	3/16" Tapered											●	●	●	●	
	1/5" Tapered															
Engine stop switch		●	●	●	●		●		●		●	●	●	●	●	●
Engine stop switch (~1240212)																
Air cleaner	Dual	●	●	●	●	●	●		●	●	●	●	●	●	●	●
	Standard															
	Oil bath															
	Cyclone							●								
Fuel tank		●	●	●	●	●	●	●	●	●	●	●	●	●	●	●
Starter motor						●				●						
Control box						●				●						
Reduction																
Muffler cover		(●)	(●)	(●)	(●)	(●)						(●)	(●)			

1

Specifications		Model	GX200RT2								
		Type	RDG4	RHG4	RMG2	SWG4	VEE9	VENN	VGGN	VPM4	VS19
Crankshaft	20 mm Ø Spline										
	21 mm Ø Spline										
	19.05 mm Ø Straight										
	20 mm Ø Straight	●	●	●	●						
	3/4" Thread										
	5/8" Thread										
	3/16" Tapered					●		●	●	●	
	1/5" Tapered						●				
Engine stop switch		●	●	●			●	●	●	●	
Engine stop switch (~1240212)											
Air cleaner	Dual	●	●	●	●			●			
	Standard					●	●		●	●	
	Oil bath										
	Cyclone										
Fuel tank											
Starter motor					●	●					
Control box											
Reduction		●	●	●							
Muffler cover		(●)	(●)								

Fuel hose, general purpose hoses and vinyl hose

- The standard part fuel hose, general purpose hose and vinyl hose may be substituted by the coiled bulk part.
- When ordering the standard part fuel hose, general purpose hose and vinyl hose use the bulk part number written in the parts catalog in brackets () underneath the part name.
- When exchanging the hose, cut and use at the specified length as mentioned in the part name.
(For the method of cutting the bulk part, and method of filling out orders etc., please refer to the instructions issued with the bulk part.)

Bulk part number of fuel hose, general purpose hose and vinyl hose.

Example: 9 5 0 0 1 - 7 5 0 0 1 - 5 0 M

Bulk part number:
Refers to the bulk part.

Marking code (fuel hose and general purpose hose)

Change code (Vinyl hose)

Indicates number mark or change sequence, however, the code for the bulk part must be strictly 0 (zero).

Types of code:

- | | | | | | |
|-------------|--|----------------|--|--------------|---|
| • Fuel hose | 2: Red outside braid
(3 mm inside dia. only) | • General hose | 1: Ash gray
2: Ash gray
3: Black
5: Black | • Vinyl hose | 1: Clear
2: Black
3: Light red
6: Light red
7: Pale black |
| | 5: Black inside braid | | | | |
| | 3: Red (3 mm inside dia. only) | | | | |
| | 4: Ash gray with red stripe
(3 mm inside dia. only) | | | | |
| | 6: Black | | | | |

Lengths:

- 001: 1 m (standard)
003: 3 m
008: 8 m } Application or specification of some parts is not settled.

I.D code: (fuel hose and general purpose hose)

- | | | | | |
|------------|--------------------|--------------------|-----------------------------|-----------------------------|
| 30: 3.0 mm | 50: 5.0 mm | 70: 7.0 mm | 11: 11 mm | 12: 12 (outside dia. 17) mm |
| 35: 3.5 mm | 55: 5.3 mm, 5.5 mm | 75: 7.3 mm, 7.5 mm | 91: 12 (outside dia. 15) mm | 14: 14 mm |
| 45: 4.5 mm | 65: 6.5 mm | 80: 8.0 mm | 92: 12 (outside dia. 16) mm | 17: 17 mm |

ID./OD. code: (vinyl hose)

- | | | | | |
|-------------------------|--------------------------|---------------------------|---------------------------|---------------------------|
| 01: ID. 2.9, OD. 6.8 mm | 12: ID. 5.0, OD. 7.0 mm | 21: ID. 8.0, OD. 9.0 mm | 37: ID. 11.0, OD. 15.0 mm | 50: ID. 16.0, OD. 19.0 mm |
| 03: ID. 3.0, OD. 6.0 mm | 10: ID. 5.0, OD. 8.0 mm | 23: ID. 8.0, OD. 12.0 mm | 38: ID. 12.0, OD. 13.0 mm | 55: ID. 17.5, OD. 20.5 mm |
| 05: ID. 3.5, OD. 6.5 mm | 11: ID. 5.0, OD. 9.0 mm | 25: ID. 9.0, OD. 11.0 mm | 39: ID. 12.0, OD. 14.0 mm | 60: ID. 22.0, OD. 27.0 mm |
| 07: ID. 4.0, OD. 7.0 mm | 14: ID. 6.0, OD. 9.0 mm | 27: ID. 9.0, OD. 13.0 mm | 40: ID. 12.0, OD. 16.0 mm | |
| 08: ID. 4.5, OD. 6.5 mm | 17: ID. 7.0, OD. 9.0 mm | 33: ID. 10.0, OD. 14.0 mm | 43: ID. 13.0, OD. 15.0 mm | |
| 09: ID. 4.5, OD. 8.0 mm | 19: ID. 7.0, OD. 11.0 mm | 36: ID. 11.0, OD. 13.0 mm | 45: ID. 14.0, OD. 18.0 mm | |

Hose type:

- 1: Fuel hose
3: Vinyl hose
5: General hose

⊙ **CAUTION: It is DANGEROUS to confuse the fuel hose with the general purpose hose or vinyl hose.**

Never use a general purpose hose or vinyl hose in place of a fuel hose or vice versa. Always use the correct bulk part in the parts catalogue, according to the service manual or the instructions issued with the bulk part.

ENGINE GROUP

C 4

E-2

CYLINDER HEAD

D 1

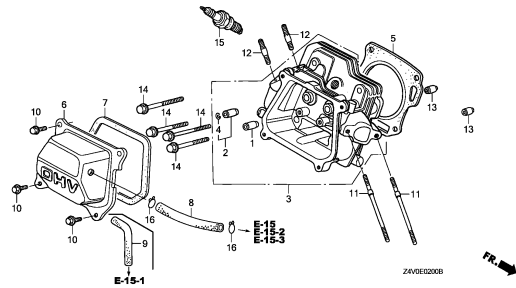

E-3

CYLINDER BARREL

D 3

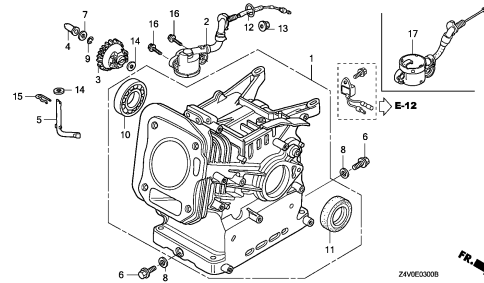

E-6

CRANKCASE COVER

D 5

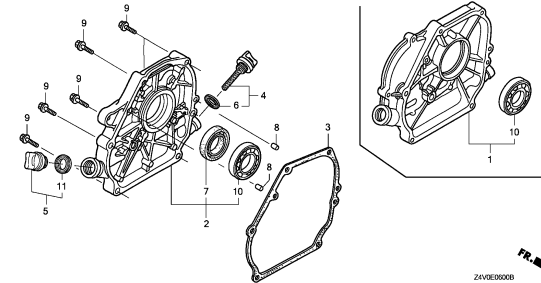

E-7

CRANKSHAFT

D 7

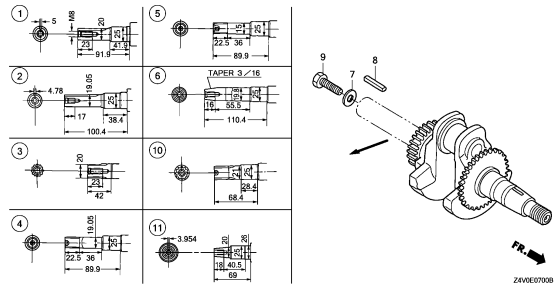

E-8

PISTON

D 8

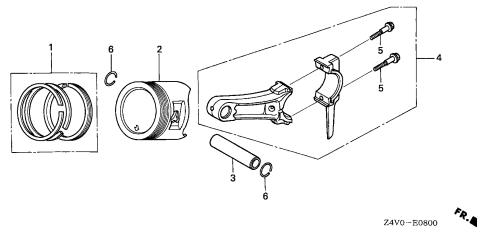

E-9

CAMSHAFT

D12

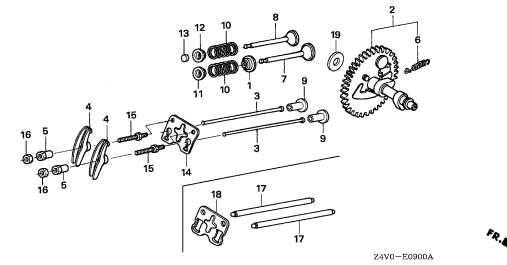

E-11

RECOIL STARTER

D15

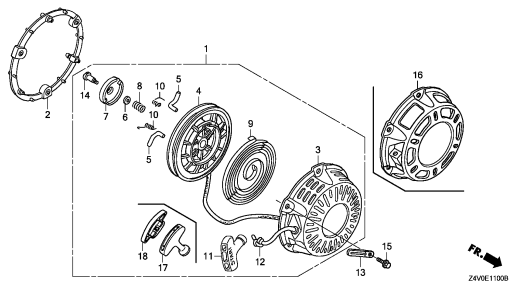

E-12

FAN COVER

E 3

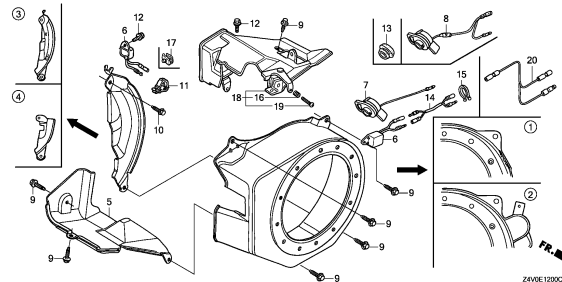

E-14

CARBURETOR(1)

E 6

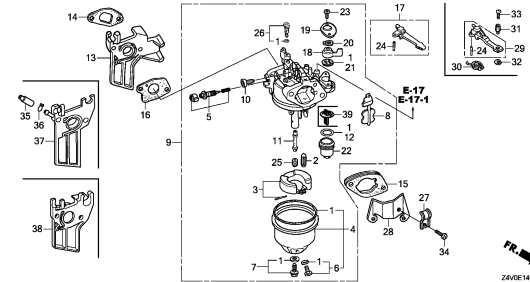

ENGINE GROUP

C 5

E-14-1

CARBURETOR(2)

E13

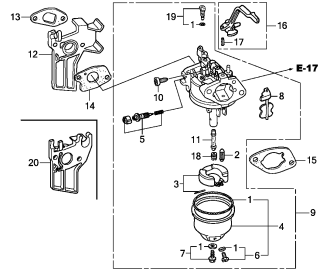

ZAVOE14010

E-15

AIR CLEANER(DUAL)

E15

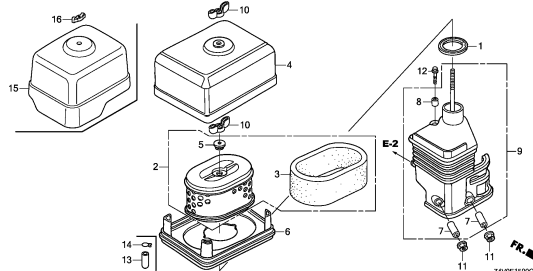

ZAVOE1500C

E-15-1

AIR CLEANER(STANDARD)

F 1

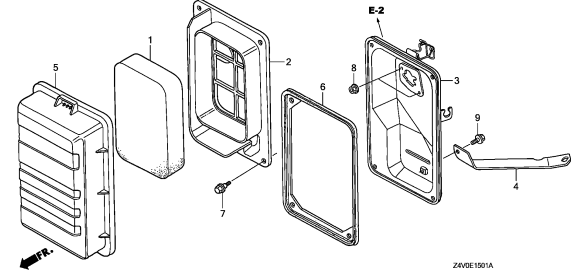

ZAVOE1501A

E-15-2

AIR CLEANER(OIL BATH)

F 2

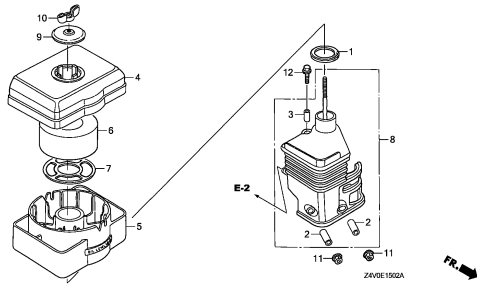

ZAVOE1502A

E-15-3

AIR CLEANER(CYCLONE)

F 3

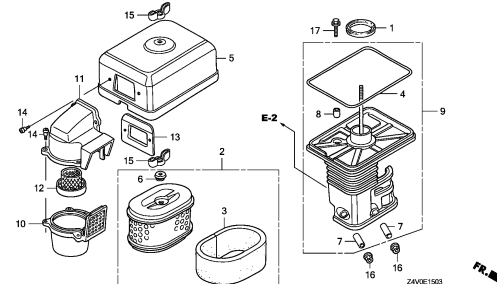

ZAVOE1503

E-16

MUFFLER

F 4

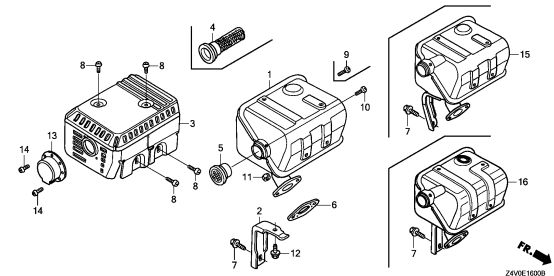

ZAVOE1600B

E-16-1

EXHAUST PIPE

F 7

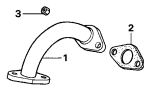

ZAVO-E1601

E-17

FUEL TANK(1)

F 8

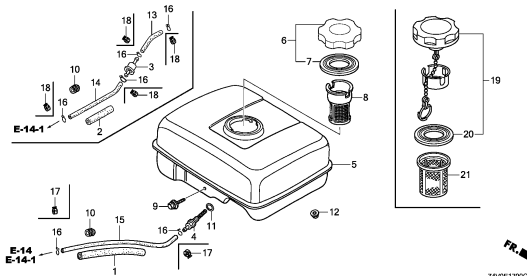

ZAVOE1700C

E-17-1

FUEL TANK(2)

F12

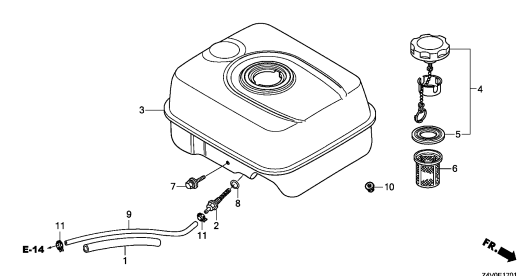

ZAVOE1701

2

ENGINE GROUP

C 6

E-19

FLYWHEEL

F13

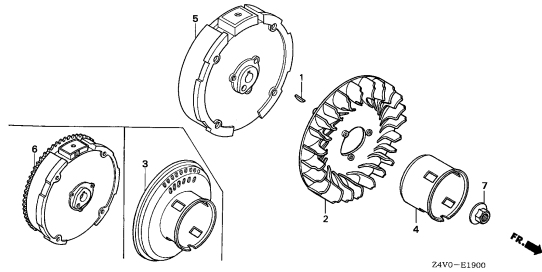

Z4VO-E1900

E-20

IGNITION COIL

F14

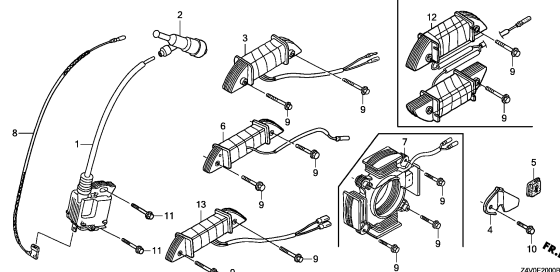

Z4VOE20000

E-21

STARTER MOTOR

F16

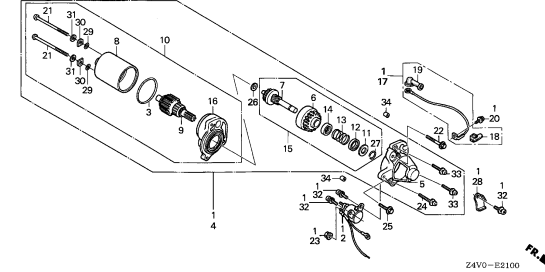

Z4VO-E2100

E-22

CONTROL

G 3

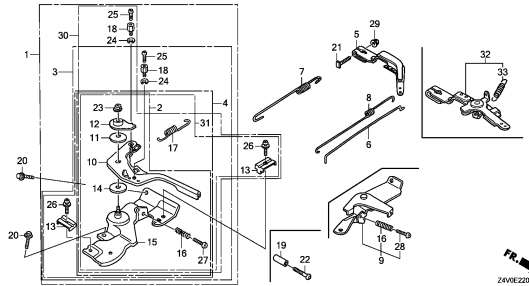

Z4VOE22000

E-22-20

AUTO THROTTLE

G 7

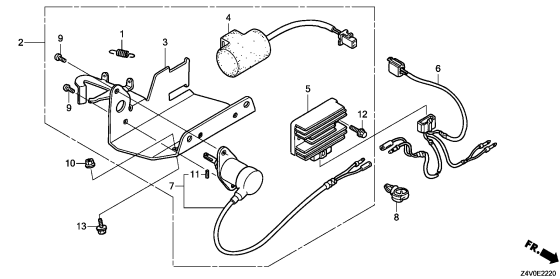

Z4VOE2220

E-23

CONTROL BOX

G 8

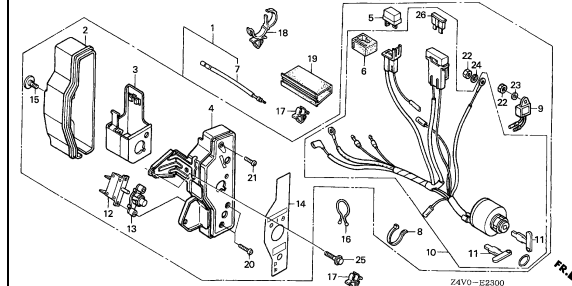

Z4VO-E2300

E-26

REDUCTION(1)

G10

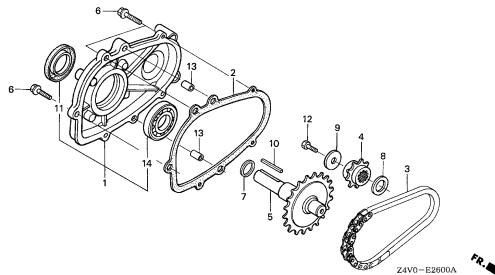

Z4VO-E2600A

E-26-1

REDUCTION(2)

G11

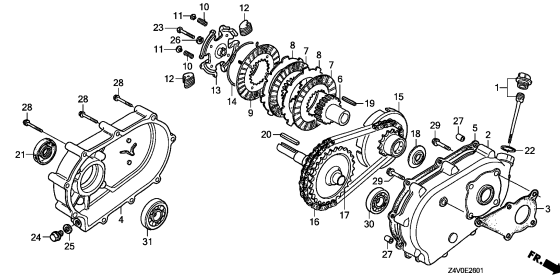

Z4VOE2601

E-26-2

REDUCTION(3)

G13

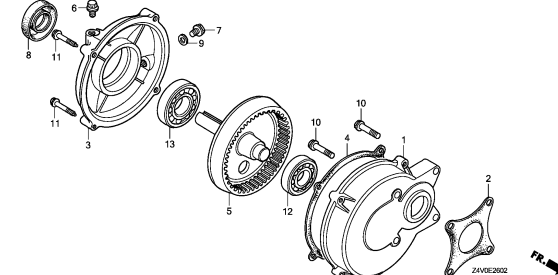

Z4VOE2602

2

ENGINE GROUP

C 7

E-28

LABEL

G14

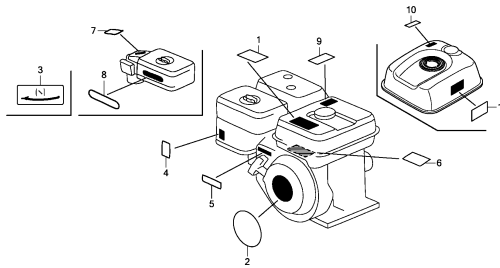

Z4VE2800

E-29

TOOL

H 1

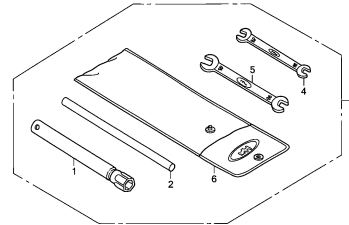

Z4VE2900A

E-40

OTHER PARTS(1)

H 2

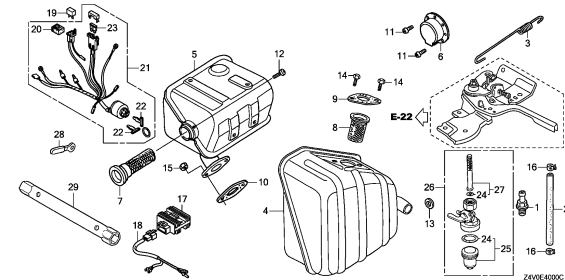

Z4VE4000C

E-40-1

OTHER PARTS(2)(LABEL)

H 4

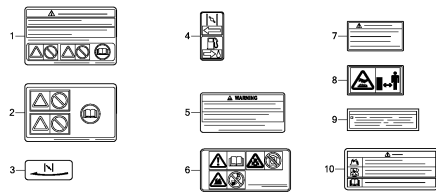

Z4VE4001D

E-40-2

OTHER PARTS(3)(AIR CLEANER)

H 6

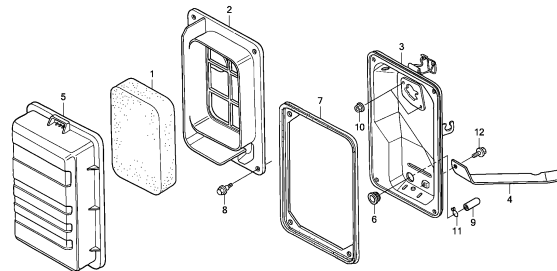

Z4VE4002

E-40-3

OTHER PARTS(4)(MUFFLER)

H 7

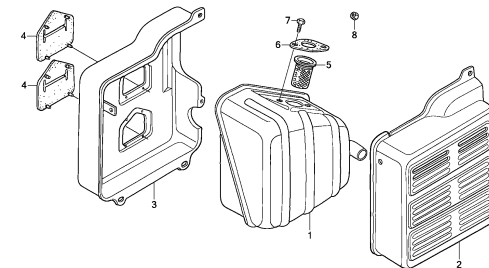

Z4VE4003

EOP-1

GASKET KIT

H 8

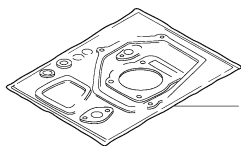

11ENG-X0003

EOP-2

MUFFLER COVER

H 9

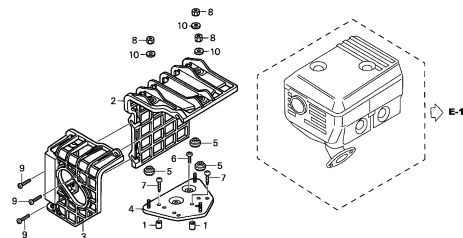

Z4V0-X0200



2

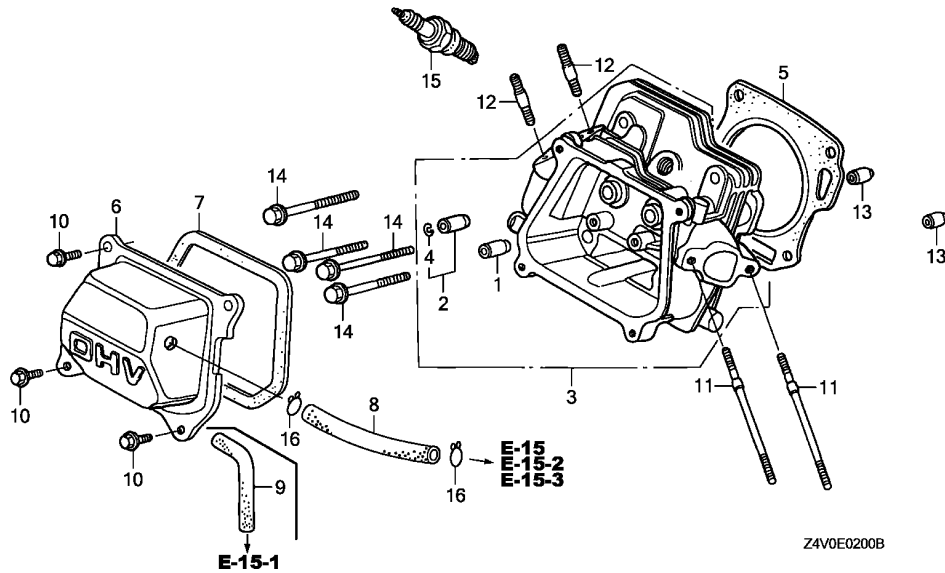

Ref. L.O.N. (Relative ref. Number) F.R.T.
No. Description

Ref. No.	Part No.	Description	Reqd. QTY				Serial No.	Parts catalogue code
			GX 200	GX 200	GX 200	GX 200		
1	12204-ZE1-306	GUIDE, IN. VALVE(O.S.)	1	1	1	1		
2	12205-ZE1-315	GUIDE, EX. VALVE(O.S.)	1	1	1	1		
3	12210-ZL0-415	HEAD COMP., CYLINDER	1	1	1	1		
4	12216-ZE5-300	CLIP, VALVE GUIDE	1	1	1	1		
5	12251-ZL0-003	GASKET, CYLINDER HEAD	1	1	1	1		
6	12310-ZE1-020	COVER COMP., HEAD	1	1	-	-	HX2, HXU, LX2, LX4, LXAU, PXU, QG2, QH26, QHQ4, QMP4, QX2, QX26, QX4, QX7, QX9, QXB2, QXD4, QXD9, QXE2, QXE4, QXE5, QXE6, QXU, RH2, RHG4, RHQ4, RMG2, RX4, RXU, SAR, SHQ2, SHQ4, SM12, SMC2, SMC4, SMCR, SWG4, SX4, SX7, SX9, SXE4, SXE5, SXU, TX2, TX4, TXD1, TXDU, TXU, TXU1, VEE9, VGG2, VGGN, VGS5, VGS9, VPM4, VPM8, VPM9, VS17, VS19, VSD, VSD1, VSD2, VSD7, VSD9, VX2, VX4, VXU, VXU1	
	12310-ZE1-842	COVER COMP., HEAD (BREATHER TUBE)	1	-	-	-	QH4, QXC9	
	12310-Z4M-000	COVER COMP., HEAD	-	-	1	1	HX2, LX4, LXAU, PXU, QG2, QH26, QHQ4, QMP4, QX2, QX4, QX9, QXAG, QXB2, QXD4, QXD9, QXE2, QXE4, QXE5, RDG4, RH2, RHG4, RHQ4, RMG2, RX4, RXU, SAR, SHQ4, SM12, SM14, SM24, SMC4, SMCR, SWG4, SX4, SX9, SXE5, SXU, TX2, TXD1, TXDU, VEE9, VENN, VGGN, VGS5, VPM4, VS19, VSD9, VXU, VXU1	
	12310-Z4M-840	-	-	1	-	QXC9, SXW9	
7	12391-ZE1-000	PACKING, HEAD COVER	1	1	1	1		
8	15721-ZH8-000	TUBE, BREATHER	1	1	1	1	HX2, HXU, LX2, LX4, LXAU, PXU, QG2, QH26, QHQ4, QMP4, QX2, QX26, QX4, QX7, QX9, QXAG, QXB2, QXD4, QXD9, QXE2, QXE4, QXE5, QXE6, QXU, RDG4, RH2, RHG4, RHQ4, RMG2, RX4, RXU, SAR, SHQ2, SHQ4, SM12, SM14, SM24, SMC2, SMC4, SMCR, SWG4, SX4, SX7, SX9, SXE4, SXE5, SXU, TX2, TX4, TXD1, TXDU, TXU, TXU1, VGG2, VGGN, VGS5, VGS9, VSD, VSD7, VSD9, VX2, VX4, VXU, VXU1	
	15721-ZE1-840	1	-	1	-	QH4, QXC9, SXW9	
9	15721-883-030	TUBE, BREATHER	1	-	-	1	VEE9, VENN, VPM4, VPM8, VPM9, VS17, VS19, VSD1, VSD2	
10	90013-883-000	BOLT, FLANGE, 6X12(CT200)	4	4	4	4		

Ref. No.	Part No.	Description	Reqd. QTY				Serial No.	Parts catalogue code
			GX 200 UT	GX 200 RT	GX 200 UT2	GX 200 RT2		
11	90043-ZE1-020	BOLT, STUD, 6X112	2	2	2	2	-----	HX2, HXU, LX2, LX4, LXAU, PXU, QG2, QH26, QH4, QHQ4, QMP4, QX2, QX26, QX4, QX7, QX9, QXAG, QXB2, QXC9, QXD4, QXD9, QXE2, QXE4, QXE5, QXE6, QXU, RDG4, RH2, RHG4, RHQ4, RMG2, RX4, RXU, SAR, SHQ2, SHQ4, SM12, SM14, SM24, SMC2, SMC4, SMCR, SWG4, SX4, SX7, SX9, SXE4, SXE5, SXU, SXW9, TX2, TX4, TXD1, TXDU, TXU, TXU1, VGG2, VGGN, VGS5, VGS9, VSD, VSD7, VSD9, VX2, VX4, VXU, VXU1
	90043-ZB2-003	BOLT, STUD, 6X94	2	-	-	2	-----	VEE9, VENN, VPM4, VPM8, VPM9, VS17, VS19, VSD1, VSD2
12	90047-ZE1-000	BOLT, STUD, 8X32	2	2	2	2	-----	
13	94301-10160	DOWEL PIN, 10X16	2	2	2	2	-----	
14	95701-08060-00	BOLT, FLANGE, 8X60	4	4	-	-	-----	HX2, HXU, QH4, QXC9, QXD4, QXD9, QXE2, QXE4, QXE5, QXE6, RH2, RHG4, RHQ4, RMG2, RX4, RXU, SAR, SHQ2, SMC2, SMCR, SWG4, SXE4, SXE5, TXD1, TXDU, VEE9, VGGN
	95723-08060-00	4	-	-	-	-----	1318360 LX2, LX4, LXAU, PXU, QG2, QH26, QHQ4, QMP4, QX2, QX26, QX4, QX7, QX9, QXB2, QXU, SHQ4, SM12, SMC4, SX4, SX7, SX9, SXU, TX2, TX4, TXU, TXU1, VGG2, VGS5, VGS9, VPM4, VPM8, VPM9, VS17, VS19, VSD, VSD1, VSD2, VSD7, VSD9, VX2, VX4, VXU, VXU1
	95701-08060-00	4	-	-	-	-----	1318361 LX2, LX4, LXAU, PXU, QG2, QH26, QHQ4, QMP4, QX2, QX26, QX4, QX7, QX9, QXB2, QXU, SHQ4, SM12, SMC4, SX4, SX7, SX9, SXU, TX2, TX4, TXU, TXU1, VGG2, VGS5, VGS9, VPM4, VPM8, VPM9, VS17, VS19, VSD, VSD1, VSD2, VSD7, VSD9, VX2, VX4, VXU, VXU1
15	98079-56855	PLUG, SPARK(W20EPR-U) (DENSO)	1	1	1	1	-----	HX2, HXU, QH4, QXC9, QXE2, QXE4, QXE5, QXE6, RDG4, RH2, RHG4, RHQ4, RMG2, RX4, RXU, SAR, SM14, SM24, SWG4, SXE4, SXE5, SXW9, VENN
	98079-55855	PLUG, SPARK(W16EPR-U) (DENSO)	(1)	(1)	(1)	(1)	-----	HX2, HXU, RDG4, RH2, RHG4, RHQ4, RMG2, RX4, RXU, SAR, SM14
	98079-56846	PLUG, SPARK(BPR6ES) (NGK)	1	1	-	-	-----	HX2, HXU, QH4, QXC9, QXE2, QXE4, QXE5, QXE6, RH2, RHG4, RHQ4, RMG2, RX4, RXU, SAR, SWG4, SXE4, SXE5
	98079-55846	PLUG, SPARK(BPR5ES) (NGK)	(1)	(1)	-	-	-----	HX2, HXU, RH2, RHG4, RHQ4, RMG2, RX4, RXU, SAR
	98079-56876	PLUG, SPARK(BPR6ES) (NGK)	1	-	-	1	-----	LX2, LX4, LXAU, PXU, QG2, QH26, QHQ4, QMP4, QX2, QX26, QX4, QX7, QX9, QXB2, QXD4, QXD9, QXU, RDG4, RHG4, RMG2, SHQ2, SHQ4, SM12, SMC2, SMC4, SMCR, SWG4, SX4, SX7, SX9, SXU, TX2, TX4, TXD1, TXDU, TXU, TXU1, VEE9, VENN, VGG2, VGGN, VGS5, VGS9, VPM4, VPM8, VPM9, VS17, VS19, VSD, VSD1, VSD2, VSD7, VSD9, VX2, VX4, VXU, VXU1
	98079-55876	PLUG, SPARK(BPR5ES) (NGK)	(1)	-	-	(1)	-----	LX2, LX4, LXAU, QG2, QH26, QHQ4, QMP4, QX2, QX26, QX4, QX7, QX9, QXB2, QXD4, QXD9, QXU, RDG4, RHG4, RMG2, SHQ2, SHQ4, SM12, TX2, TX4, TXD1, TXDU, TXU, TXU1, VEE9, VGS5, VGS9, VPM4, VPM8, VPM9, VS17, VS19, VSD, VSD1, VSD2, VSD7, VSD9, VX2, VX4, VXU, VXU1
	98079-56876	PLUG, SPARK(BPR6ES) (NGK)	-	-	1	-	-----	
	98079-55876	PLUG, SPARK(BPR5ES) (NGK)	-	-	(1)	-	-----	HX2, LX4, LXAU, QG2, QH26, QHQ4, QMP4, QX2, QX4, QX9, QXAG, QXB2, QXD4, QXD9, RH2, RHQ4, RX4, RXU, SAR, SHQ4, SM12, SM14, TX2, TXD1, TXDU, VGS5, VSD9, VXU, VXU1
16	95002-80000	CLIP, TUBE(C12)	2	-	2	-	-----	QH4, QXC9, SXW9



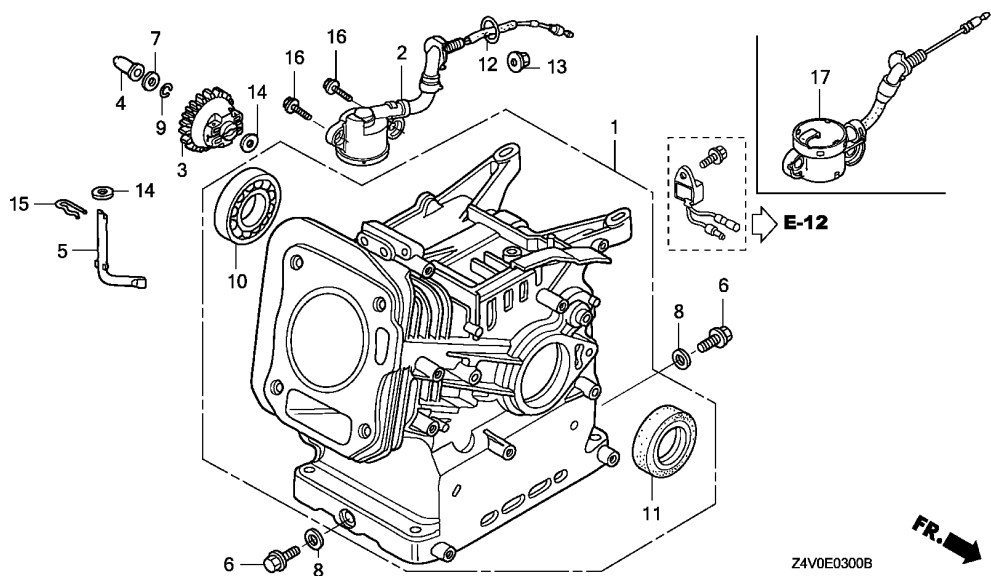

Ref. No.	L.O.N. (Relative ref. Number)	Description	F.R.T.
----------	-------------------------------	-------------	--------

2

Ref. No.	Part No.	Description	Reqd. QTY				Serial No.	Parts catalogue code
			GX 200 UT	GX 200 RT	GX 200 UT2	GX 200 RT2		
1	12000-Z0V-406	BARREL ASSY., CYLINDER	1	1	-	-	HX2, HXU, LX2, LX4, LXAU, PXU, QG2, QH4, QX2, QX26, QX4, QX7, QX9, QXC9, QXD4, QXD9, QXE2, QXE4, QXE5, QXE6, QXU, RX4, RXU, SAR, SM12, SMC2, SMC4, SMC, SWG4, SX4, SX7, SX9, SXE4, SXE5, SXU, TX2, TX4, TXD1, TXDU, TXU, TXU1, VEE9, VGG2, VGGN, VGS5, VGS9, VPM4, VPM8, VPM9, VS17, VS19, VSD, VSD1, VSD2, VSD7, VSD9, VX2, VX4, VXU, VXU1	
	12000-Z0V-405		1	1	-	-	QH26, QHQ4, QMP4, QXB2, RH2, RHG4, RHQ4, RMG2, SHQ2, SHQ4	
	12000-Z4V-406		-	-	1	1	HX2, LX4, LXAU, PXU, QG2, QX2, QX4, QX9, QXC9, QXD4, QXD9, QXE2, QXE4, QXE5, RX4, RXU, SAR, SM12, SM14, SM24, SMC4, SMC, SWG4, SX4, SX9, SXE5, SXU, TX2, TXD1, TXDU, VEE9, VENN, VGGN, VGS5, VPM4, VS19, VSD9, VXU, VXU1	
	12000-Z4V-405		-	-	1	1	QH26, QHQ4, QMP4, QXB2, RH2, RHG4, RHQ4, RMG2, SHQ4	
	12000-Z4V-416	BARREL ASSY., CYLINDER (OIL ALERT)	-	-	1	-	QXAG, SXW9	
	12000-Z4V-415	BARREL ASSY., CYLINDER	-	-	-	1	RDG4	
2	15510-ZE1-043	SWITCH ASSY., OIL LEVEL	1	-	-	-	QXE4, QXE6, SXE4	
	15510-ZE1-033		1	-	-	-	1409967 LX2, LX4, PXU, QG2, QX2, QX26, QX4, QX7, QX9, QXU, SM12, SMC4, SX4, SX7, SX9, SXU, TX2, TX4, TXU, TXU1, VGG2, VGS5, VGS9, VPM4, VPM8, VPM9, VS17, VS19, VSD, VSD1, VSD2, VSD7, VSD9, VX2, VX4, VXU, VXU1	
3	16506-ZL0-000	GOVERNOR ASSY.	1	1	1	1		
4	16531-ZE1-000	SLIDER, GOVERNOR	1	1	1	1		
5	16541-ZE1-000	SHAFT, GOVERNOR ARM	1	1	1	1		
6	90131-ZE1-000	BOLT, DRAIN PLUG	2	2	2	2		
7	90451-ZE1-000	WASHER, THRUST, 6MM	1	1	1	1		
8	90601-ZE1-000	WASHER, DRAIN PLUG, 10.2MM	2	2	2	2		
9	90602-ZE1-000	CLIP, GOVERNOR HOLDER	1	1	1	1		
10	91001-Z4X-003	BEARING, RADIAL BALL (6205)						
		(NSK)	1	1	1	1		
	91001-ZF1-004	BEARING, RADIAL BALL (6205SH)						
		(KOYO)	1	1	1	1		

Ref. No.	Part No.	Description	Reqd. QTY				Serial No.	Parts catalogue code	
			GX 200 UT	GX 200 RT	GX 200 UT2	GX 200 RT2			
10)	91001-ZF1-003	BEARING, RADIAL BALL(6205TMB) (NTN)	1	1	1	1	-----	HX2, HXU, LX2, LX4, LXAU, PXU, QG2, QH26, QH4, QHQ4, QMP4, QX2, QX26, QX4, QX7, QX9, QXAG, QXB2, QXC9, QXD4, QXD9, QXE2, QXE4, QXE5, QXE6, QXU, RDG4, RH2, RHG4, RHQ4, RMG2, RX4, RXU, SAR, SHQ2, SHQ4, SM12, SM14, SM24, SMC2, SMC4, SMCR, SWG4, SX4, SX7, SX9, SXE4, SXE5, SXU, SXW9, TX2, TX4, TXD1, TXDU, TXU, TXU1, VEE9, VENN, VGG2, VGGN, VGS5, VGS9, VPM4, VPM8, VPM9, VS17, VS19, VSD, VSD2, VSD7, VSD9, VX2, VX4, VXU, VXU1	
11	91201-ZOT-801	OIL SEAL, 25X41X6	1	1	1	1			
12	91353-671-004	O-RING, 14MM(NOK)	1	1	1	1	-----	HX2, HXU, LX2, LX4, LXAU, PXU, QG2, QH4, QX2, QX26, QX4, QX7, QX9, QXAG, QXC9, QXD4, QXD9, QXE2, QXE4, QXE5, QXE6, QXU, RX4, RXU, SAR, SM12, SM14, SM24, SMC2, SMC4, SMCR, SWG4, SX4, SX7, SX9, SXE4, SXE5, SXU, SXW9, TX2, TX4, TXD1, TXDU, TXU, TXU1, VEE9, VENN, VGG2, VGGN, VGS5, VGS9, VPM4, VPM8, VPM9, VS17, VS19, VSD, VSD1, VSD2, VSD7, VSD9, VX2, VX4, VXU, VXU1	
13	94050-10000	NUT, FLANGE, 10MM	1	1	1	1	-----	HX2, HXU, LX2, LX4, LXAU, PXU, QG2, QH4, QX2, QX26, QX4, QX7, QX9, QXAG, QXC9, QXD4, QXD9, QXE2, QXE4, QXE5, QXE6, QXU, RX4, RXU, SAR, SM12, SM14, SM24, SMC2, SMC4, SMCR, SWG4, SX4, SX7, SX9, SXE4, SXE5, SXU, SXW9, TX2, TX4, TXD1, TXDU, TXU, TXU1, VEE9, VENN, VGG2, VGGN, VGS5, VGS9, VPM4, VPM8, VPM9, VS17, VS19, VSD, VSD1, VSD2, VSD7, VSD9, VX2, VX4, VXU, VXU1	
14	94101-06800	WASHER, PLAIN, 6MM	2	2	2	2			
15	94251-08000	PIN, LOCK, 8MM	1	1	1	1			
16	95701-06012-00	BOLT, FLANGE, 6X12	2	2	2	2	-----	HX2, HXU, LX2, LX4, LXAU, PXU, QG2, QH4, QX2, QX26, QX4, QX7, QX9, QXAG, QXC9, QXD4, QXD9, QXE2, QXE4, QXE5, QXE6, QXU, RX4, RXU, SAR, SM12, SM14, SM24, SMC2, SMC4, SMCR, SWG4, SX4, SX7, SX9, SXE4, SXE5, SXU, SXW9, TX2, TX4, TXD1, TXDU, TXU, TXU1, VEE9, VENN, VGG2, VGGN, VGS5, VGS9, VPM4, VPM8, VPM9, VS17, VS19, VSD, VSD1, VSD2, VSD7, VSD9, VX2, VX4, VXU, VXU1	
17	35480-ZOT-003	SWITCH ASSY., OIL LEVEL	1	1	-	-	-----	HX2, HXU, LXAU, QH4, QXC9, QXD4, QXD9, QXE2, QXE5, RX4, RXU, SAR, SMC2, SMC4, SMCR, SWG4, SXE5, TXD1, TXDU, VEE9, VGGN	
			1	-	-	-	1409968	-----	LX2, LX4, PXU, QG2, QX2, QX26, QX4, QX7, QX9, QXU, SM12, SMC4, SX4, SX7, SX9, SXU, TX2, TX4, TXU, TXU1, VGG2, VGS5, VGS9, VPM4, VPM8, VPM9, VS17, VS19, VSD, VSD1, VSD2, VSD7, VSD9, VX2, VX4, VXU, VXU1
			-	-	1	1	-----	HX2, LX4, LXAU, PXU, QG2, QX2, QX4, QX9, QXAG, QXC9, QXD4, QXD9, QXE2, QXE4, QXE5, RX4, RXU, SAR, SM12, SM14, SM24, SMC4, SMCR, SWG4, SX4, SX9, SXE5, SXU, SXW9, TX2, TXD1, TXDU, VEE9, VENN, VGGN, VGS5, VPM4, VS19, VSD9, VXU, VXU1	



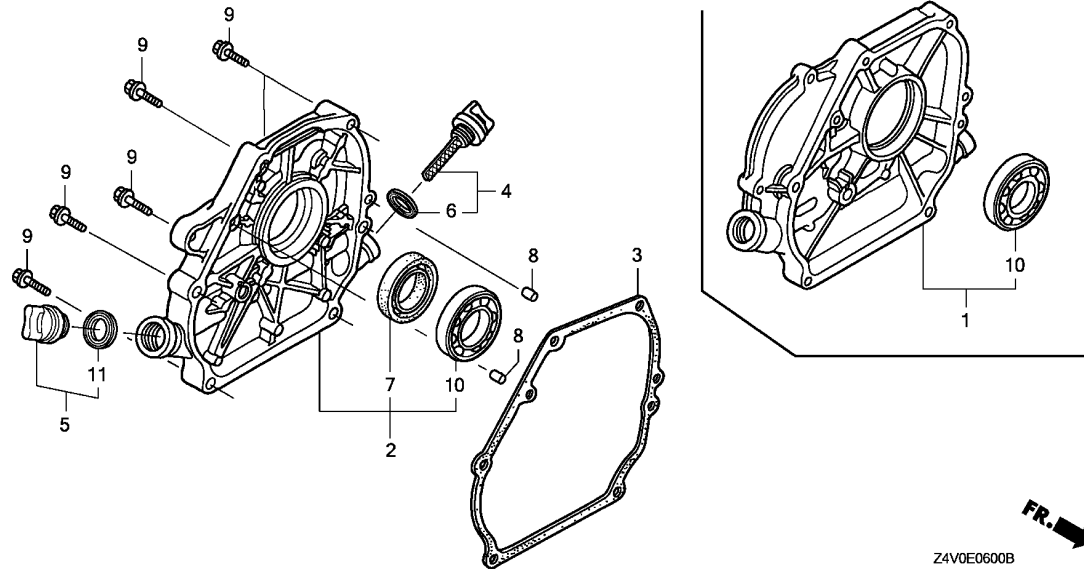

Ref. No.	L.O.N.	(Relative ref. Number) Description	F.R.T.
----------	--------	------------------------------------	--------

Ref. No.	Part No.	Description	Reqd. QTY				Serial No.	Parts catalogue code
			GX 200 UT	GX 200 RT	GX 200 UT2	GX 200 RT2		
1	11300-ZE1-613	COVER ASSY., CRANKCASE	1	-	-	-	LX2,LX4,LXAU	
2	11300-ZE1-634	COVER ASSY., CRANKCASE	1	1	-	-	HX2,HXU,SHQ2,SHQ4,SMC2,SMC4,SMCR,SWG4,SX4,SX7,SX9,SXE4,SXE5 SXU	
	11300-ZE1-020	1	1	-	-	RH2,RHG4,RHQ4,RMG2,RX4,RXU,SAR,SM12	
	11300-ZE1-642	1	-	-	-	PXU,QG2,QH26,QH4,QHQ4,QMP4,QX2,QX26,QX4,QX7,QX9,QXB2,QXC9,QXD4 QXD9,QXE2,QXE4,QXE5,QXE6,QXU,TX2,TX4,TXD1,TXDU,TXU,TXU1,VEE9 VGG2,VGGN,VGS5,VGS9,VPM4,VPM8,VPM9,VS17,VS19,VSD,VSD1,VSD2 VSD7,VSD9,VX2,VX4,VXU,VXU1	
	11300-Z4M-630	-	-	1	1	HX2,SHQ4,SM24,SMC4,SMCR,SWG4,SX4,SX9,SXE5,SXU,VENN	
	11300-Z4M-640	-	-	1	1	PXU,QG2,QH26,QHQ4,QMP4,QX2,QX4,QX9,QXAG,QXB2,QXC9,QXD4,QXD9 QXE2,QXE4,QXE5,TX2,TXD1,TXDU,VEE9,VGGN,VGS5,VPM4,VS19,VSD9,VXU VXU1	
	11300-Z4M-000	-	-	1	1	RDG4,RH2,RHG4,RHQ4,RMG2,RX4,RXU,SAR,SM12,SM14,SXW9	
	11300-ZE1-642	-	-	1	1	1001180 PXU,QG2,QH26,QHQ4,QMP4,QX2,QX4,QX9,QXB2,QXC9,QXD4,QXD9,QXE2 QXE4,QXE5,TX2,TXD1,TXDU,VEE9,VGGN,VGS5,VPM4,VS19,VSD9,VXU,VXU1 LX4,LXAU	
3	11381-ZL0-000	PACKING, CASE COVER	1	1	-	-	HX2,HXU,LX2,LX4,LXAU,PXU,QG2,QH26,QH4,QHQ4,QMP4,QX2,QX26,QX4 QX7,QX9,QXB2,QXC9,QXD4,QXD9,QXE2,QXE4,QXE5,QXE6,QXU,RH2,RHG4 RHQ4,RMG2,RX4,RXU,SAR,SHQ2,SHQ4,SM12,SMC2,SMC4,SWG4,SX4,SX7 SX9,SXE4,SXE5,SXU,TX2,TX4,TXD1,TXDU,TXU,TXU1,VEE9,VGG2,VGGN VGS5,VGS9,VPM4,VPM8,VPM9,VS17,VS19,VSD,VSD1,VSD2,VSD7,VSD9,VX2 VX4,VXU,VXU1	
	11381-ZH8-801	PACKING, CASE COVER (NON ASBESTOS)	1	-	-	-	SMCR	
	4	15600-Z0T-810	1	1	1	1		
	5	15600-ZG4-003	1	1	-	-	QH4,QXE2,QXE5,RHG4,RMG2,SAR,SWG4,SXE5	

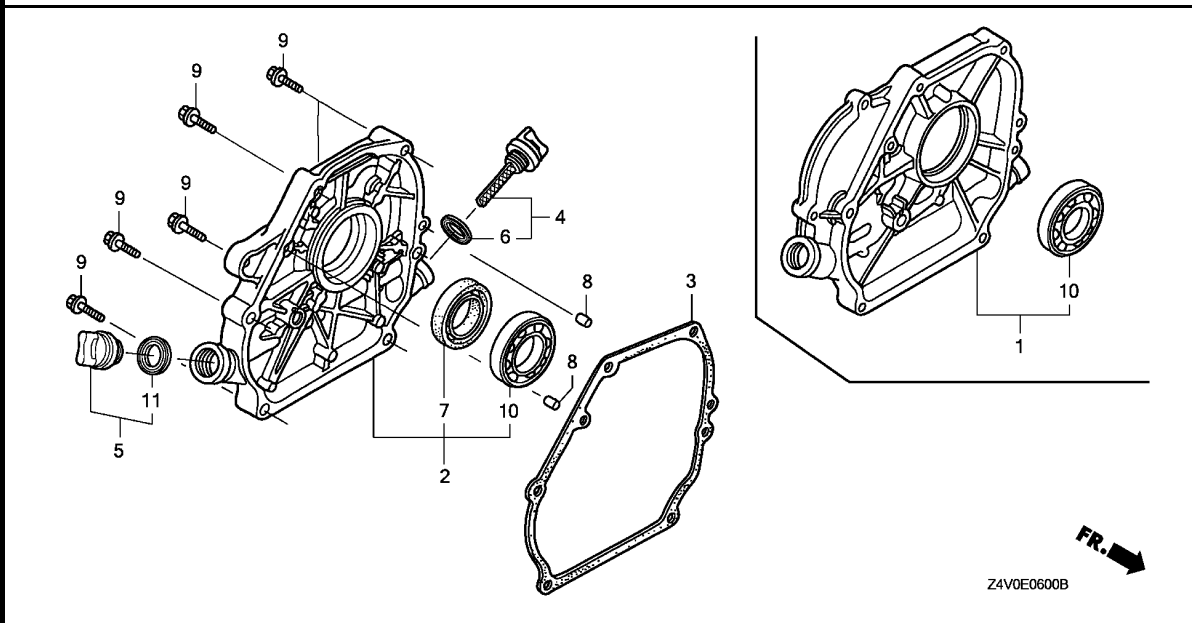

Ref. No.	Part No.	Description	Reqd. QTY				Serial No.	Parts catalogue code
			GX 200 UT	GX 200 RT	GX 200 UT2	GX 200 RT2		
(5)	15600-Z0T-820	CAP ASSY., OIL FILLER	1	-	-	1	-----	HX2, HXU, LX2, LX4, LXAU, PXU, QG2, QH26, QHQ4, QMP4, QX2, QX26, QX4, QX7, QX9, QXB2, QXC9, QXD4, QXD9, QXE4, QXE6, QXU, RDG4, RH2, RHG4, RHQ4, RMG2, RX4, RXU, SHQ2, SHQ4, SM12, SMC2, SMC4, SMCR, SWG4, SX4, SX7, SX9, SXE4, SXU, TX2, TX4, TXD1, TXDU, TXU, TXU1, VEE9, VENN, VGG2, VGGN, VGS5, VGS9, VPM4, VPM8, VPM9, VS17, VS19, VSD, VSD1, VSD2, VSD7, VSD9, VX2, VX4, VXU, VXU1
			-	-	1	-		
6	15625-Z0T-800	PACKING, OIL FILLER CAP	1	1	1	1	-----	HX2, HXU, PXU, QG2, QH26, QH4, QHQ4, QMP4, QX2, QX26, QX4, QX7, QX9, QXAG, QXB2, QXC9, QXD4, QXD9, QXE2, QXE4, QXE5, QXE6, QXU, RDG4, RH2, RHG4, RHQ4, RMG2, RX4, RXU, SAR, SHQ2, SHQ4, SM12, SM14, SM24, SMC2, SMC4, SMCR, SWG4, SX4, SX7, SX9, SXE4, SXE5, SXU, SXW9, TX2, TX4, TXD1, TXDU, TXU, TXU1, VEE9, VENN, VGG2, VGGN, VGS5, VGS9, VPM4, VPM8, VPM9, VS17, VS19, VSD, VSD1, VSD2, VSD7, VSD9, VX2, VX4, VXU, VXU1
7	91201-Z0T-801	OIL SEAL, 25X41X6	1	1	1	1	-----	HX2, HXU, LX2, LX4, LXAU, PXU, QG2, QH26, QHQ4, QMP4, QX2, QX26, QX4, QX7, QX9, QXAG, QXB2, QXC9, QXD4, QXD9, QXE4, QXE6, QXU, RDG4, RH2, RHG4, RHQ4, RMG2, RX4, RXU, SAR, SHQ2, SHQ4, SM12, SM14, SM24, SMC2, SMC4, SMCR, SWG4, SX4, SX7, SX9, SXE4, SXE5, SXU, SXW9, TX2, TX4, TXD1, TXDU, TXU, TXU1, VEE9, VENN, VGG2, VGGN, VGS5, VGS9, VPM4, VPM8, VPM9, VS17, VS19, VSD, VSD1, VSD2, VSD7, VSD9, VX2, VX4, VXU, VXU1
8	94301-08140	DOWEL PIN, 8X14	2	2	2	2	-----	QH4, QXE2, QXE5, RHG4, RMG2, SAR, SWG4, SXE5
9	95701-08032-00	BOLT, FLANGE, 8X32	6	6	6	6	-----	HX2, HXU, LX2, LX4, LXAU, PXU, QG2, QH26, QHQ4, QMP4, QX2, QX26, QX4, QX7, QX9, QXB2, QXC9, QXD4, QXD9, QXE4, QXE6, QXU, RDG4, RH2, RHG4, RHQ4, RMG2, RX4, RXU, SHQ2, SHQ4, SM12, SMC2, SMC4, SMCR, SWG4, SX4, SX7, SX9, SXE4, SXU, TX2, TX4, TXD1, TXDU, TXU, TXU1, VEE9, VENN, VGG2, VGGN, VGS5, VGS9, VPM4, VPM8, VPM9, VS17, VS19, VSD, VSD1, VSD2, VSD7, VSD9, VX2, VX4, VXU, VXU1
10	96100-62050-00	BEARING, RADIAL BALL, 6205 ..	1	1	1	1	-----	
11	15625-ZE1-003	PACKING, OIL FILLER CAP	1	1	-	-	-----	QH4, QXE2, QXE5, RHG4, RMG2, SAR, SWG4, SXE5
	15625-Z0T-800	1	-	-	1	-----	HX2, HXU, LX2, LX4, LXAU, PXU, QG2, QH26, QHQ4, QMP4, QX2, QX26, QX4, QX7, QX9, QXB2, QXC9, QXD4, QXD9, QXE4, QXE6, QXU, RDG4, RH2, RHG4, RHQ4, RMG2, RX4, RXU, SHQ2, SHQ4, SM12, SMC2, SMC4, SMCR, SWG4, SX4, SX7, SX9, SXE4, SXU, TX2, TX4, TXD1, TXDU, TXU, TXU1, VEE9, VENN, VGG2, VGGN, VGS5, VGS9, VPM4, VPM8, VPM9, VS17, VS19, VSD, VSD1, VSD2, VSD7, VSD9, VX2, VX4, VXU, VXU1
			-	-	1	-		



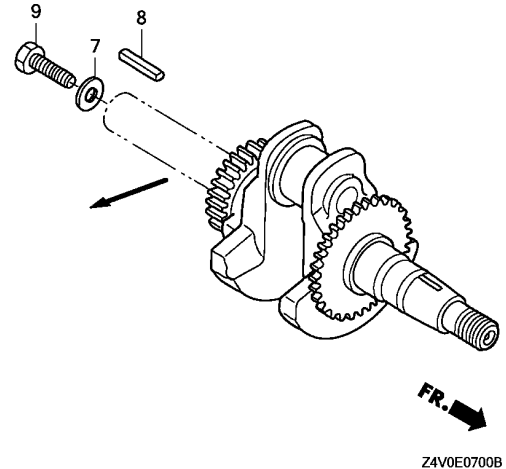
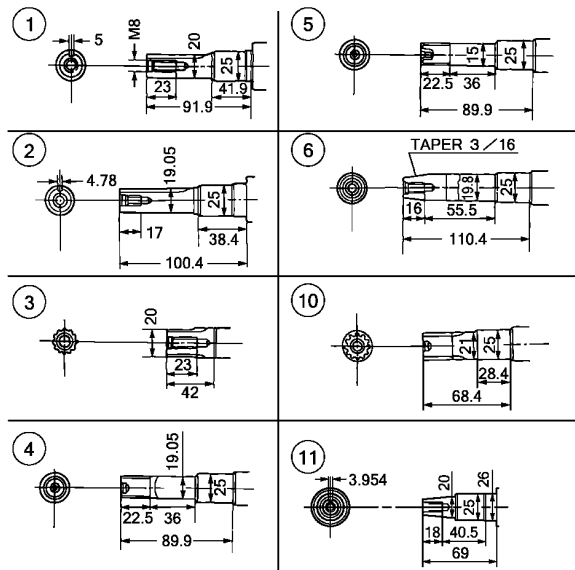

Ref. No.	L.O.N. (Relative ref. Number)	Description	F.R.T.
----------	-------------------------------	-------------	--------

Ref. No.	Part No.	Description	Reqd. QTY				Serial No.	Parts catalogue code
			GX 200 UT	GX 200 RT	GX 200 UT2	GX 200 RT2		
1	13310-ZL0-020	CRANKSHAFT COMP.	1	1	1	1	RDG4, RH2, RHG4, RHQ4, RMG2, RX4, RXU, SAR, SHQ2, SHQ4, SM12, SM14, SM24, SMC2, SMC4, SMCR, SWG4, SX4, SXE4, SXE5, SXU, SXW9	
	13310-ZL0-882	1	-	1	-	SX7, SX9	
2	13310-ZL0-602	CRANKSHAFT COMP.	1	-	1	-	QG2, QH26, QH4, QHQ4, QMP4, QX2, QX26, QX4, QXAG, QXB2, QXC9, QXD4, QXE2, QXE4, QXE5, QXE6, QXU	
	13310-ZL0-892	1	-	1	-	QX7, QX9, QXD9	
3	13310-ZL0-612	CRANKSHAFT COMP.	1	-	-	-	LXAU	
	13310-ZL0-611	1	-	-	1044714	LX2, LX4	
	13310-ZL0-612	1	-	-	1044715	LX2, LX4	
		-	-	1	-	LX4, LXAU	
4	13310-ZL0-652	CRANKSHAFT COMP.	1	-	1	-	PXU	
5	13310-ZL0-662	CRANKSHAFT COMP.	1	-	1	-	TX2, TX4, TXD1, TXDU, TXU, TXU1	
6	13310-ZL0-872	CRANKSHAFT COMP.	1	-	1	1	VEE9, VGS5, VGS9, VPM8, VPM9, VS17, VS19, VSD7, VSD9	
	13310-ZL0-672	1	-	1	1	VGG2, VGGN, VPM4, VSD, VSD1, VSD2, VX2, VX4, VXU, VXU1	
7	90473-842-000	WASHER, 8MM	1	1	1	-	QH4, SAR, SM12, SM14, SM24	
8	90741-883-810	KEY, 5X5X33 (YELLOW)	1	1	1	1	SAR, SHQ2, SHQ4, SM12, SM14, SM24, SMC2, SMC4, SMCR, SWG4, SX4, SX7, SX9, SXE4, SXE5, SXU	
	90745-ZE1-600	KEY, 4.78X4.78X38	1	-	1	-	QG2, QH4, QMP4, QX2, QX26, QX4, QX7, QX9, QXAG, QXB2, QXC9, QXD4, QXD9, QXE2, QXE4, QXE5, QXE6, QXU	
9	92101-08025-0A	BOLT, HEX., 8X25	1	1	1	-	SAR, SM12, SM14, SM24	
	90003-ZE1-000	BOLT, HEX., 5/16"	1	-	-	-	QH4	
10	13310-ZL0-622	CRANKSHAFT COMP.	1	-	1	-	HX2, HXU	
11	13310-ZL0-A02	CRANKSHAFT COMP.	-	-	-	1	VENN	

E-8

PISTON

D 8

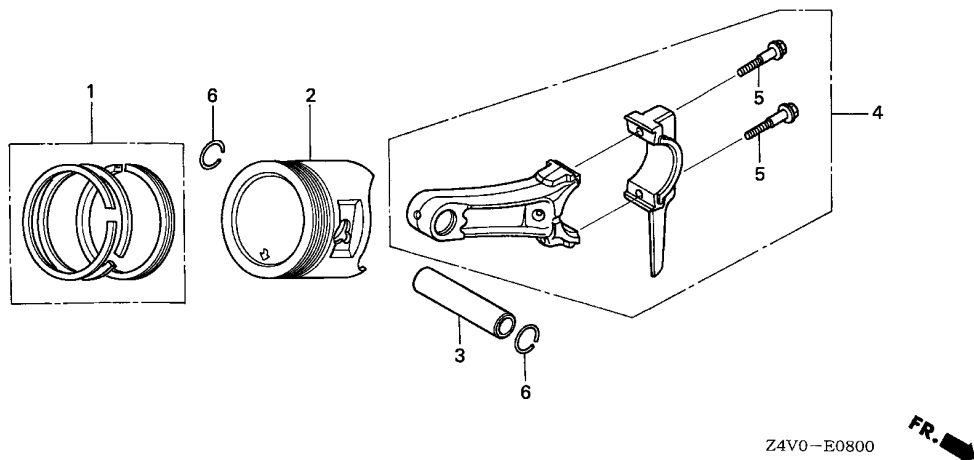

Ref. L.O.N. (Relative ref. Number) F.R.T.
No. Description

Ref. No.	Part No.	Description	Reqd. QTY				Serial No.	Parts catalogue code
			GX 200 UT	GX 200 RT	GX 200 UT2	GX 200 RT2		
1	13010-Z4K-004	RING SET, PISTON(STD.) (TEIKOKU)	1	1	-	-	1259679 -----	HX2, HXU, LX2, LX4, LXAU, PXU, QG2, QH26, QH4, QHQ4, QMP4, QX2, QX26, QX4, QX7, QX9, QXB2, QXC9, QXD4, QXD9, QXE2, QXE4, QXE5, QXE6, QXU, RH2, RHG4, RHQ4, RMG2, RX4, RXU, SAR, SHQ2, SHQ4, SM12, SMC2, SMC4, SWG4, SX4, SX7, SX9, SXE4, SXE5, SXU, TX2, TX4, TXD1, TXDU, TXU, TXU1, VEE9, VGG2, VGGN, VGS5, VGS9, VPM4, VPM8, VPM9, VS17, VS19, VSD, VSD1, VSD2, VSD7, VSD9, VX2, VX4, VXU, VXU1
	13011-Z4K-004	RING SET, PISTON(0.25) (TEIKOKU)	(1)	(1)	-	-	1259679 -----	HX2, HXU, LX2, LX4, LXAU, PXU, QG2, QH26, QH4, QHQ4, QMP4, QX2, QX26, QX4, QX7, QX9, QXB2, QXC9, QXD4, QXD9, QXE2, QXE4, QXE5, QXE6, QXU, RH2, RHG4, RHQ4, RMG2, RX4, RXU, SAR, SHQ2, SHQ4, SM12, SMC2, SMC4, SWG4, SX4, SX7, SX9, SXE4, SXE5, SXU, TX2, TX4, TXD1, TXDU, TXU, TXU1, VEE9, VGG2, VGGN, VGS5, VGS9, VPM4, VPM8, VPM9, VS17, VS19, VSD, VSD1, VSD2, VSD7, VSD9, VX2, VX4, VXU, VXU1
	13012-Z4K-004	RING SET, PISTON(0.50) (TEIKOKU)	(1)	(1)	-	-	1259679 -----	HX2, HXU, LX2, LX4, LXAU, PXU, QG2, QH26, QH4, QHQ4, QMP4, QX2, QX26, QX4, QX7, QX9, QXB2, QXC9, QXD4, QXD9, QXE2, QXE4, QXE5, QXE6, QXU, RH2, RHG4, RHQ4, RMG2, RX4, RXU, SAR, SHQ2, SHQ4, SM12, SMC2, SMC4, SWG4, SX4, SX7, SX9, SXE4, SXE5, SXU, TX2, TX4, TXD1, TXDU, TXU, TXU1, VEE9, VGG2, VGGN, VGS5, VGS9, VPM4, VPM8, VPM9, VS17, VS19, VSD, VSD1, VSD2, VSD7, VSD9, VX2, VX4, VXU, VXU1
	13013-Z4K-004	RING SET, PISTON(0.75) (TEIKOKU)	(1)	(1)	-	-	1259679 -----	HX2, HXU, LX2, LX4, LXAU, PXU, QG2, QH26, QH4, QHQ4, QMP4, QX2, QX26, QX4, QX7, QX9, QXB2, QXC9, QXD4, QXD9, QXE2, QXE4, QXE5, QXE6, QXU, RH2, RHG4, RHQ4, RMG2, RX4, RXU, SAR, SHQ2, SHQ4, SM12, SMC2, SMC4, SWG4, SX4, SX7, SX9, SXE4, SXE5, SXU, TX2, TX4, TXD1, TXDU, TXU, TXU1, VEE9, VGG2, VGGN, VGS5, VGS9, VPM4, VPM8, VPM9, VS17, VS19, VSD, VSD1, VSD2, VSD7, VSD9, VX2, VX4, VXU, VXU1

2

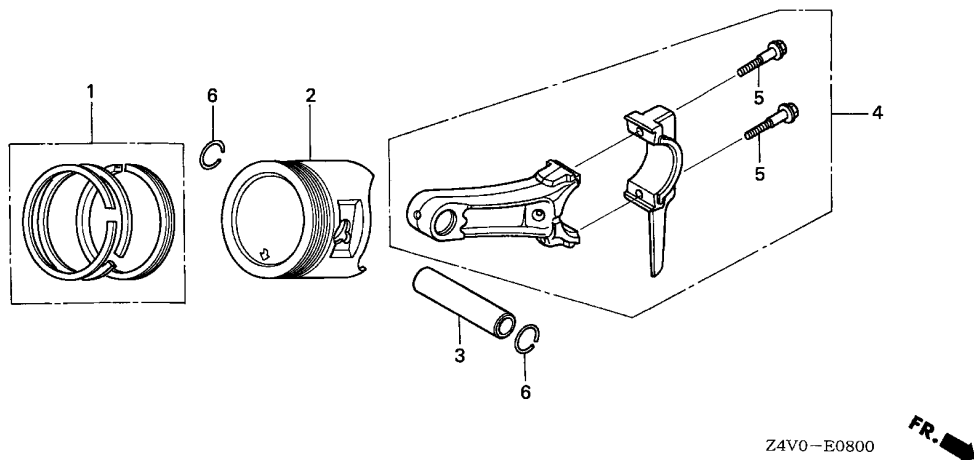

2

Ref. No.	Part No.	Description	Reqd. QTY				Serial No.	Parts catalogue code
			GX 200 UT	GX 200 RT	GX 200 UT2	GX 200 RT2		
(1)	13010-Z4K-004	RING SET, PISTON(STD.) (TEIKOKU)	1	-	-	-	----- SMCR	
	13010-Z4M-003	RING SET, PISTON(STD.) (RIKEN)	1	-	-	-	----- SMCR	
	13011-Z4K-004	RING SET, PISTON(0.25) (TEIKOKU)	(1)	-	-	-	----- SMCR	
	13011-Z4M-003	RING SET, PISTON(0.25) (RIKEN)	(1)	-	-	-	----- SMCR	
	13012-Z4K-004	RING SET, PISTON(0.50) (TEIKOKU)	(1)	-	-	-	----- SMCR	
	13012-Z4M-003	RING SET, PISTON(0.50) (RIKEN)	(1)	-	-	-	----- SMCR	
	13013-Z4K-004	RING SET, PISTON(0.75) (TEIKOKU)	(1)	-	-	-	----- SMCR	
	13013-Z4M-003	RING SET, PISTON(0.75) (RIKEN)	(1)	-	-	-	----- SMCR	
	13010-Z0T-801	RING SET, PISTON(STD.) (RIKEN)	1	-	-	-	1259678 LX2, LX4, PXU, QG2, QH26, QHQ4, QX2, QX26, QX4, QX7, QX9, QXB2, QXU, SHQ4 SM12, SMC4, SX4, SX7, SX9, SXU, TX2, TX4, TXU, TXU1, VGG2, VGS5, VGS9, VPM4 VPM8, VPM9, VS17, VS19, VSD, VSD1, VSD2, VSD7, VSD9, VX2, VX4, VXU, VXU1	
	13011-Z0T-801	RING SET, PISTON(0.25) (RIKEN)	(1)	-	-	-	1259678 LX2, LX4, PXU, QG2, QH26, QHQ4, QX2, QX26, QX4, QX7, QX9, QXB2, QXU, SHQ4 SM12, SMC4, SX4, SX7, SX9, SXU, TX2, TX4, TXU, TXU1, VGG2, VGS5, VGS9, VPM4 VPM8, VPM9, VS17, VS19, VSD, VSD1, VSD2, VSD7, VSD9, VX2, VX4, VXU, VXU1	
	13012-Z0T-801	RING SET, PISTON(0.50) (RIKEN)	(1)	-	-	-	1259678 LX2, LX4, PXU, QG2, QH26, QHQ4, QX2, QX26, QX4, QX7, QX9, QXB2, QXU, SHQ4 SM12, SMC4, SX4, SX7, SX9, SXU, TX2, TX4, TXU, TXU1, VGG2, VGS5, VGS9, VPM4 VPM8, VPM9, VS17, VS19, VSD, VSD1, VSD2, VSD7, VSD9, VX2, VX4, VXU, VXU1	
	13013-Z0T-801	RING SET, PISTON(0.75) (RIKEN)	(1)	-	-	-	1259678 LX2, LX4, PXU, QG2, QH26, QHQ4, QX2, QX26, QX4, QX7, QX9, QXB2, QXU, SHQ4 SM12, SMC4, SX4, SX7, SX9, SXU, TX2, TX4, TXU, TXU1, VGG2, VGS5, VGS9, VPM4 VPM8, VPM9, VS17, VS19, VSD, VSD1, VSD2, VSD7, VSD9, VX2, VX4, VXU, VXU1	
	13010-Z4M-003	RING SET, PISTON(STD.) (RIKEN)	1	-	-	-	1259679 ----- LX2, LX4, LXAU, PXU, QG2, QH26, QHQ4, QMP4, QX2, QX26, QX4, QX7, QX9, QXB2 QXD4, QXD9, QXU, SHQ2, SHQ4, SM12, SMC2, SMC4, SX4, SX7, SX9, SXU, TX2, TX4 TXD1, TXDU, TXU, TXU1, VEE9, VGG2, VGGN, VGS5, VGS9, VPM4, VPM8, VPM9 VS17, VS19, VSD, VSD1, VSD2, VSD7, VSD9, VX2, VX4, VXU, VXU1	

Ref. No.	Part No.	Description	Reqd. QTY				Serial No.	Parts catalogue code
			GX 200 UT	GX 200 RT	GX 200 UT2	GX 200 RT2		
(1)	13011-Z4M-003	RING SET, PISTON(O.25) (RIKEN)	(1)	-	-	-	1259679	LX2,LX4,LXAU, PXU, QG2, QH26, QHQ4, QMP4, QX2, QX26, QX4, QX7, QX9, QXB2, QXD4, QXD9, QXU, SHQ2, SHQ4, SM12, SMC2, SMC4, SX4, SX7, SX9, SXU, TX2, TX4, TXD1, TXDU, TXU, TXU1, VEE9, VGG2, VGGN, VGS5, VGS9, VPM4, VPM8, VPM9, VS17, VS19, VSD, VSD1, VSD2, VSD7, VSD9, VX2, VX4, VXU, VXU1
	13012-Z4M-003	RING SET, PISTON(O.50) (RIKEN)	(1)	-	-	-	1259679	LX2,LX4,LXAU, PXU, QG2, QH26, QHQ4, QMP4, QX2, QX26, QX4, QX7, QX9, QXB2, QXD4, QXD9, QXU, SHQ2, SHQ4, SM12, SMC2, SMC4, SX4, SX7, SX9, SXU, TX2, TX4, TXD1, TXDU, TXU, TXU1, VEE9, VGG2, VGGN, VGS5, VGS9, VPM4, VPM8, VPM9, VS17, VS19, VSD, VSD1, VSD2, VSD7, VSD9, VX2, VX4, VXU, VXU1
	13013-Z4M-003	RING SET, PISTON(O.75) (RIKEN)	(1)	-	-	-	1259679	LX2,LX4,LXAU, PXU, QG2, QH26, QHQ4, QMP4, QX2, QX26, QX4, QX7, QX9, QXB2, QXD4, QXD9, QXU, SHQ2, SHQ4, SM12, SMC2, SMC4, SX4, SX7, SX9, SXU, TX2, TX4, TXD1, TXDU, TXU, TXU1, VEE9, VGG2, VGGN, VGS5, VGS9, VPM4, VPM8, VPM9, VS17, VS19, VSD, VSD1, VSD2, VSD7, VSD9, VX2, VX4, VXU, VXU1
	13010-Z4K-004	RING SET, PISTON(STD.) (TEIKOKU)	-	-	1	1		
	13010-Z4M-003	RING SET, PISTON(STD.) (RIKEN)	-	-	1	1		
	13011-Z4K-004	RING SET, PISTON(O.25) (TEIKOKU)	-	-	(1)	(1)		
	13011-Z4M-003	RING SET, PISTON(O.25) (RIKEN)	-	-	(1)	(1)		
	13012-Z4K-004	RING SET, PISTON(O.50) (TEIKOKU)	-	-	(1)	(1)		
	13012-Z4M-003	RING SET, PISTON(O.50) (RIKEN)	-	-	(1)	(1)		
	13013-Z4K-004	RING SET, PISTON(O.75) (TEIKOKU)	-	-	(1)	(1)		
	13013-Z4M-003	RING SET, PISTON(O.75) (RIKEN)	-	-	(1)	(1)		
2	13102-ZL0-020	PISTON(O.25)	(1)	(1)	-	-		HX2, HXU, LXAU, QH4, QMP4, QXC9, QXD4, QXD9, QXE2, QXE4, QXE5, QXE6, RH2, RHG4, RHQ4, RMG2, RX4, RXU, SAR, SHQ2, SMC2, SMCR, SWG4, SXE4, SXE5, TXD1, TXDU, VEE9, VGGN, VSD1
	13103-ZL0-020	PISTON(O.50)	(1)	(1)	-	-		HX2, HXU, LXAU, QH4, QMP4, QXC9, QXD4, QXD9, QXE2, QXE4, QXE5, QXE6, RH2, RHG4, RHQ4, RMG2, RX4, RXU, SAR, SHQ2, SMC2, SMCR, SWG4, SXE4, SXE5, TXD1, TXDU, VEE9, VGGN, VSD1
	13104-ZL0-020	PISTON(O.75)	(1)	(1)	-	-		HX2, HXU, LXAU, QH4, QMP4, QXC9, QXD4, QXD9, QXE2, QXE4, QXE5, QXE6, RH2, RHG4, RHQ4, RMG2, RX4, RXU, SAR, SHQ2, SMC2, SMCR, SWG4, SXE4, SXE5, TXD1, TXDU, VEE9, VGGN, VSD1
	13101-ZL0-020	PISTON(STD.)	1	1	-	-	1653638	HX2, HXU, LXAU, QH4, QMP4, QXC9, QXD4, QXD9, QXE2, QXE4, QXE5, QXE6, RH2, RHG4, RHQ4, RMG2, RX4, RXU, SAR, SHQ2, SMC2, SWG4, SXE4, SXE5, TXD1, TXDU, VEE9, VGGN, VSD1
	13101-Z4V-800	1	1	-	-	1653639	HX2, HXU, LX2, LX4, LXAU, PXU, QG2, QH26, QH4, QHQ4, QMP4, QX2, QX26, QX4, QX7, QX9, QXB2, QXC9, QXD4, QXD9, QXE2, QXE4, QXE5, QXE6, QXU, RH2, RHG4, RHQ4, RMG2, RX4, RXU, SAR, SHQ2, SHQ4, SM12, SMC2, SMC4, SWG4, SX4, SX7, SX9, SXE4, SXE5, SXU, TX2, TX4, TXD1, TXDU, TXU, TXU1, VEE9, VGG2, VGGN, VGS5, VGS9, VPM4, VPM8, VPM9, VS17, VS19, VSD, VSD1, VSD2, VSD7, VSD9, VX2, VX4, VXU, VXU1
	13101-ZL0-020	1	-	-	-		SMCR
	13101-Z0T-800	1	-	-	-	1259678	LX2, LX4, PXU, QG2, QH26, QHQ4, QX2, QX26, QX4, QX7, QX9, QXB2, QXU, SHQ4, SM12, SMC4, SX4, SX7, SX9, SXU, TX2, TX4, TXU, TXU1, VGG2, VGS5, VGS9, VPM4, VPM8, VPM9, VS17, VS19, VSD, VSD1, VSD2, VSD7, VSD9, VX2, VX4, VXU, VXU1
	13102-Z0T-800	PISTON(O.25)	(1)	-	-	-	1259678	LX2, LX4, PXU, QG2, QH26, QHQ4, QX2, QX26, QX4, QX7, QX9, QXB2, QXU, SHQ4, SM12, SMC4, SX4, SX7, SX9, SXU, TX2, TX4, TXU, TXU1, VGG2, VGS5, VGS9, VPM4, VPM8, VPM9, VS17, VS19, VSD, VSD1, VSD2, VSD7, VSD9, VX2, VX4, VXU, VXU1
	13103-Z0T-800	PISTON(O.50)	(1)	-	-	-	1259678	LX2, LX4, PXU, QG2, QH26, QHQ4, QX2, QX26, QX4, QX7, QX9, QXB2, QXU, SHQ4, SM12, SMC4, SX4, SX7, SX9, SXU, TX2, TX4, TXU, TXU1, VGG2, VGS5, VGS9, VPM4, VPM8, VPM9, VS17, VS19, VSD, VSD1, VSD2, VSD7, VSD9, VX2, VX4, VXU, VXU1
	13104-Z0T-800	PISTON(O.75)	(1)	-	-	-	1259678	LX2, LX4, PXU, QG2, QH26, QHQ4, QX2, QX26, QX4, QX7, QX9, QXB2, QXU, SHQ4, SM12, SMC4, SX4, SX7, SX9, SXU, TX2, TX4, TXU, TXU1, VGG2, VGS5, VGS9, VPM4, VPM8, VPM9, VS17, VS19, VSD, VSD1, VSD2, VSD7, VSD9, VX2, VX4, VXU, VXU1
	13102-ZL0-020	PISTON(O.25)	(1)	-	-	-	1259679	LX2, LX4, PXU, QG2, QH26, QHQ4, QX2, QX26, QX4, QX7, QX9, QXB2, QXU, SHQ4, SM12, SMC4, SX4, SX7, SX9, SXU, TX2, TX4, TXU, TXU1, VGG2, VGS5, VGS9, VPM4, VPM8, VPM9, VS17, VS19, VSD, VSD2, VSD7, VSD9, VX2, VX4, VXU, VXU1



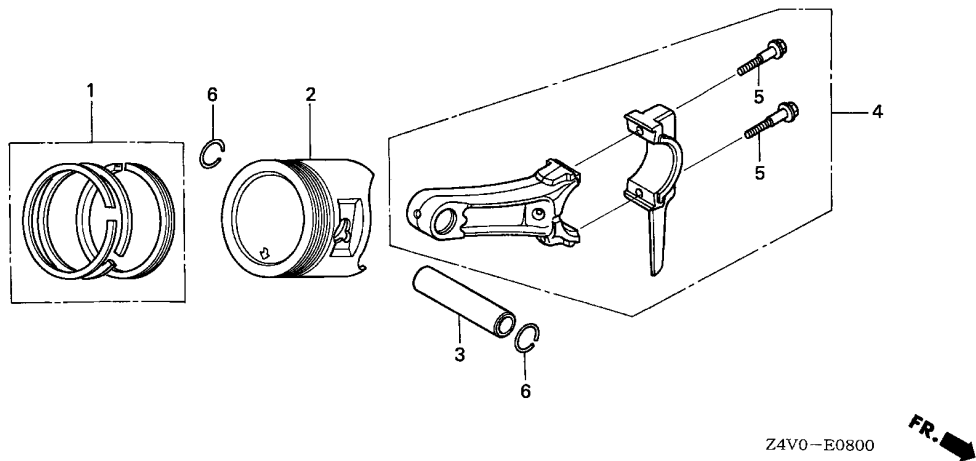

Ref. No.	Part No.	Description	Reqd. QTY				Serial No.	Parts catalogue code
			GX 200 UT	GX 200 RT	GX 200 UT2	GX 200 RT2		
(2)	13103-ZL0-020	PISTON(0.50)	(1)	-	-	-	1259679	LX2,LX4,PXU,QG2,QH26,QHQ4,QX2,QX26,QX4,QX7,QX9,QXB2,QXU,SHQ4,SM12,SMC4,SX4,SX7,SX9,SXU, TX2, TX4, TXU, TXU1, VGG2, VGS5, VGS9, VPM4, VPM8, VPM9, VS17, VS19, VSD, VSD2, VSD7, VSD9, VX2, VX4, VXU, VXU1
	13104-ZL0-020	PISTON(0.75)	(1)	-	-	-	1259679	LX2,LX4,PXU,QG2,QH26,QHQ4,QX2,QX26,QX4,QX7,QX9,QXB2,QXU,SHQ4,SM12,SMC4,SX4,SX7,SX9,SXU, TX2, TX4, TXU, TXU1, VGG2, VGS5, VGS9, VPM4, VPM8, VPM9, VS17, VS19, VSD, VSD2, VSD7, VSD9, VX2, VX4, VXU, VXU1
	13101-ZL0-020	PISTON(STD.)	1	-	-	-	1259679 1653638	LX2,LX4,PXU,QG2,QH26,QHQ4,QX2,QX26,QX4,QX7,QX9,QXB2,QXU,SHQ4,SM12,SMC4,SX4,SX7,SX9,SXU, TX2, TX4, TXU, TXU1, VGG2, VGS5, VGS9, VPM4, VPM8, VPM9, VS17, VS19, VSD, VSD2, VSD7, VSD9, VX2, VX4, VXU, VXU1
	13101-Z4V-800	-	-	1	1		
	13102-ZL0-020	PISTON(0.25)	-	-	(1)	(1)		
	13103-ZL0-020	PISTON(0.50)	-	-	(1)	(1)		
	13104-ZL0-020	PISTON(0.75)	-	-	(1)	(1)		
3	13111-ZE1-000	PIN, PISTON	1	1	-	-		
	13111-Z4M-000	-	-	1	1		
4	13200-ZOT-800	ROD ASSY., CONNECTING(TH)	1	1	1	1		
5	90001-ZE1-000	BOLT, CONNECTING ROD	2	2	2	2		
6	90551-ZE1-000	CLIP, PISTON PIN, 18MM	2	2	2	2		

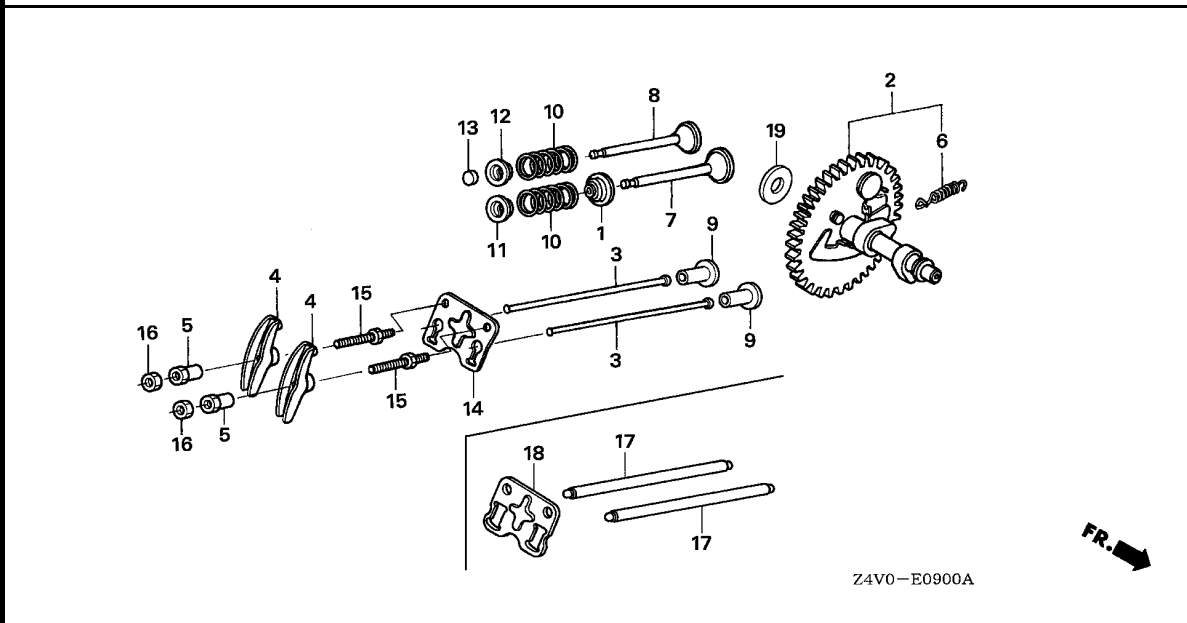

Z4V0-E0900A

Ref. No. L.O.N. (Relative ref. Number) Description F.R.T.

Ref. No.	Part No.	Description	Reqd. QTY				Serial No.	Parts catalogue code
			GX 200 UT	GX 200 RT	GX 200 UT2	GX 200 RT2		
1	12209-ZH8-003	SEAL, VALVE STEM	1	1	-	-		
	12209-Z4M-801	-	-	1	1		
2	14100-ZL0-000	CAMSHAFT ASSY.	1	1	1	1	HX2, HXU, LX2, LX4, LXAU, PXU, QG2, QH26, QH4, QHQ4, QMP4, QX2, QX26, QX4, QXAG, QXB2, QXC9, QXE2, QXE4, QXE5, QXE6, QXU, RDG4, RH2, RHG4, RHQ4, RMG2, RX4, RXU, SAR, SHQ2, SHQ4, SM12, SM14, SM24, SMC2, SMC4, SMCR, SX4, SXE4, SXE5, SXU, SXW9, TX2, TX4, TXD1, TXDU, TXU, TXU1, VENN, VGG2, VGGN, VPM4, VSD, VSD1, VSD2, VX2, VX4, VXU, VXU1	
	14100-ZL0-801	CAMSHAFT ASSY. (DUTY START) ..	1	1	1	1	----- QXD4, SWG4	
	14100-Z0V-820	CAMSHAFT ASSY. (TH)	1	-	-	-	----- QX7, SX7, VGS5, VS17, VSD7	
	14100-ZL0-870	CAMSHAFT ASSY.	1	-	-	-	----- QX7, SX7, VGS5, VSD7	
	14100-Z0V-880	1	-	-	-	----- QX9, SX9, VEE9, VGS9, VPM8, VPM9, VS19, VSD9	
	14100-Z0V-890	CAMSHAFT ASSY. (DUTY START) ..	1	-	-	-	----- QXD9	
	14100-Z0V-820	CAMSHAFT ASSY. (TH)	-	-	1	1	----- QX9, SX9, VEE9, VGS5, VS19, VSD9	
	14100-Z4V-890	CAMSHAFT ASSY. (DUTY START) ..	-	-	1	-	----- QXD9	
3	14410-ZE1-010	ROD, PUSH	2	2	-	2	HX2, HXU, LX2, LX4, LXAU, PXU, QG2, QH26, QH4, QHQ4, QMP4, QX2, QX26, QX4, QX7, QXB2, QXC9, QXD4, QXE2, QXE4, QXE5, QXE6, QXU, RDG4, RH2, RHG4, RHQ4, RMG2, RX4, RXU, SAR, SHQ2, SHQ4, SM12, SMC2, SMC4, SMCR, SWG4, SX4, SX7, SXE4, SXE5, SXU, TX2, TX4, TXD1, TXDU, TXU, TXU1, VENN, VGG2, VGGN, VGS5, VPM4, VS17, VSD, VSD1, VSD2, VSD7, VX2, VX4, VXU, VXU1	
			-	-	2	-	----- HX2, LX4, LXAU, PXU, QG2, QH26, QH4, QHQ4, QMP4, QX2, QX4, QXAG, QXB2, QXC9, QXE2, QXE4, QXE5, RH2, RHQ4, RX4, RXU, SAR, SHQ4, SM12, SM14, SM24, SMC4, SMCR, SX4, SXE5, SXU, SXW9, TX2, TXD1, TXDU, VXU, VXU1	
4	14431-ZE1-000	ARM, VALVE ROCKER	2	2	2	2		
5	14451-ZE1-013	PIVOT, ROCKER ARM	2	2	2	2		
6	14568-ZE1-000	SPRING, WEIGHT RETURN	1	1	1	1		
7	14711-ZF1-000	VALVE, IN.	1	1	1	1		



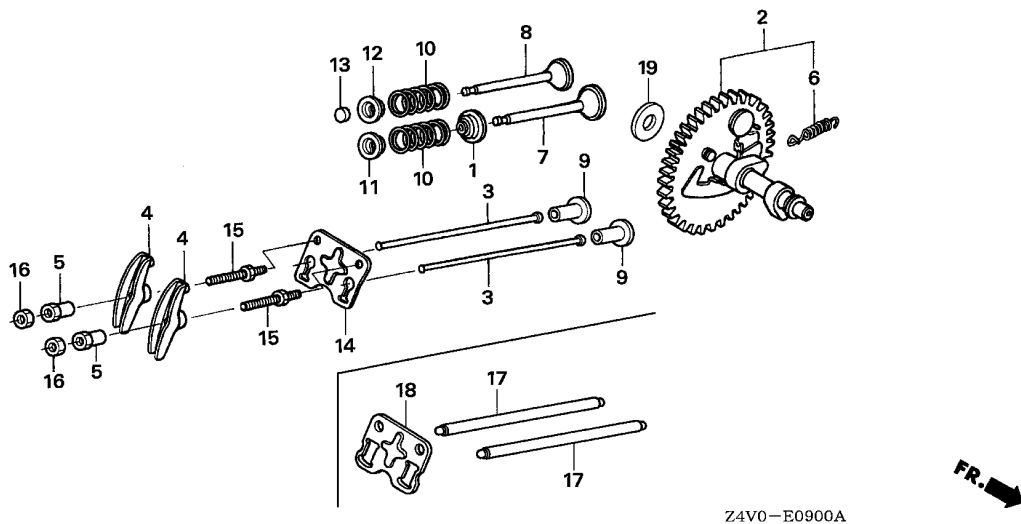

Z4V0-E0900A

Ref. No.	Part No.	Description	Reqd. QTY				Serial No.	Parts catalogue code
			GX 200 UT	GX 200 RT	GX 200 UT2	GX 200 RT2		
8	14721-ZF1-000	VALVE, EX.	1	1	1	1	-----	HX2,HXU,LX2,LX4,LXAU,QG2,QH26,QH4,QHQ4,QMP4,QX2,QX26,QX4,QX7,QX9,QXAG,QXB2,QXC9,QXD4,QXD9,QXE2,QXE4,QXE5,QXE6,QXU,RDG4,RH2,RHG4,RHQ4,RMG2,RX4,RXU,SAR,SHQ2,SHQ4,SM12,SM14,SM24,SMC2,SMC4,SMCR,SWG4,SX4,SX7,SX9,SXE4,SXE5,SXU,SXW9,VEE9,VENN,VGG2,VGGN,VGS5,VGS9,VPM4,VPM8,VPM9,VS17,VS19,VSD,VSD1,VSD2,VSD7,VSD9,VX2,VX4,VXU,VXU1
	14721-ZH8-810	VALVE, EX.(STELLITE)	1	-	1	-	-----	PXU,TX2,TX4,TXD1,TXDU,TXU,TXU1
9	14731-ZL0-000	LIFTER, VALVE	2	2	2	2	-----	
10	14751-ZF1-000	SPRING, VALVE	2	2	2	2	-----	HX2,HXU,LX2,LX4,LXAU,PXU,QG2,QH26,QH4,QHQ4,QMP4,QX2,QX26,QX4,QX7,QX9,QXAG,QXB2,QXC9,QXD4,QXD9,QXE2,QXE4,QXE5,QXE6,QXU,RH2,RHQ4,RMG2,RX4,RXU,SAR,SHQ2,SHQ4,SM12,SM14,SM24,SMC2,SMC4,SMCR,SWG4,SX4,SX7,SX9,SXE4,SXE5,SXU,SXW9,TX2,TX4,TXD1,TXDU,TXU,TXU1,VEE9,VENN,VGG2,VGGN,VGS5,VGS9,VPM4,VPM8,VPM9,VS17,VS19,VSD,VSD1,VSD2,VSD7,VSD9,VX2,VX4,VXU,VXU1
	14751-ZH8-940	-	2	-	2	-----	RDG4,RHG4
11	14771-ZE1-000	RETAINER, IN. VALVE SPRING ..	1	1	1	1	-----	
12	14773-Z4X-000	RETAINER, EX. VALVE SPRING ..	1	1	-	-	-----	HX2,HXU,QH4,QXC9,QXD4,QXD9,QXE2,QXE4,QXE5,QXE6,RH2,RHG4,RHQ4,RMG2,RX4,RXU,SAR,SHQ2,SMC2,SMCR,SWG4,SXE4,SXE5,VEE9
	14773-ZE1-000	1	-	-	-	-----	LX2,LX4,LXAU,PXU,QG2,QH26,QHQ4,QMP4,QX2,QX26,QX4,QX7,QX9,QXB2,QXU,SHQ4,SM12,SMC4,SX4,SX7,SX9,SXU,TX2,TX4,TXD1,TXDU,TXU,TXU1,VGG2,VGGN,VGS5,VGS9,VPM4,VPM8,VPM9,VS17,VS19,VSD,VSD1,VSD2,VSD7,VSD9,VX2,VX4,VXU,VXU1
	14773-Z4X-000	-	-	1	1	-----	
13	14781-ZE1-000	ROTATOR, VALVE	1	1	1	1	-----	

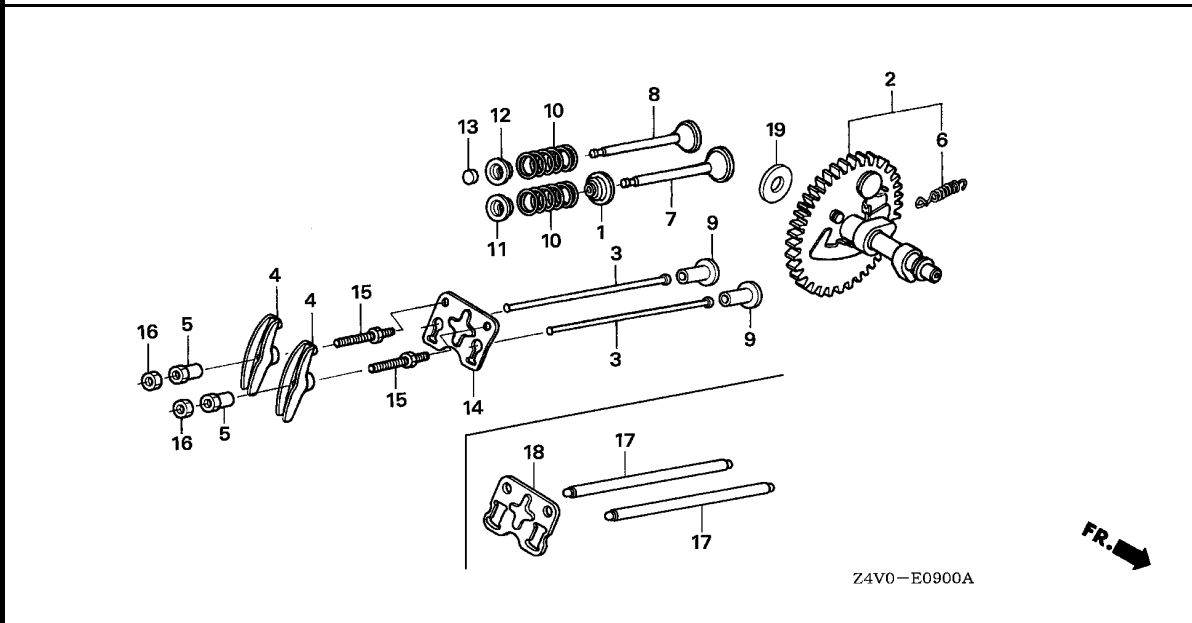

Ref. No.	Part No.	Description	Reqd. QTY				Serial No.	Parts catalogue code
			GX 200 UT	GX 200 RT	GX 200 UT2	GX 200 RT2		
14	14791-ZE1-010	PLATE, PUSH ROD GUIDE	1	1	-	1	HX2, HXU, LX2, LX4, LXAU, PXU, QG2, QH26, QH4, QHQ4, QMP4, QX2, QX26, QX4, QX7, QXB2, QXC9, QXD4, QXE2, QXE4, QXE5, QXE6, QXU, RDG4, RH2, RHG4, RHQ4, RMG2, RX4, RXU, SAR, SHQ2, SHQ4, SM12, SMC2, SMC4, SMCR, SWG4, SX4, SX7, SXE4, SXE5, SXU, TX2, TX4, TXD1, TXDU, TXU, TXU1, VENN, VGG2, VGGN, VGS5, VPM4, VS17, VSD, VSD1, VSD2, VSD7, VX2, VX4, VXU, VXU1	
			-	-	1	-	HX2, LX4, LXAU, PXU, QG2, QH26, QH4, QMP4, QX2, QX4, QXAG, QXB2, QXC9, QXE2, QXE4, QXE5, RH2, RHQ4, RX4, RXU, SAR, SHQ4, SM12, SM14, SM24, SMC4, SMCR, SX4, SXE5, SXU, SXW9, TX2, TXD1, TXDU, VXU, VXU1	
15	90012-ZE0-010	BOLT, PIVOT, 8MM	2	2	2	2		
16	90206-ZE1-000	NUT, PIVOT ADJUSTING	2	2	2	2		
17	14410-Z0V-880	ROD COMP., PUSH	2	-	-	-	QX9, QXD9, SX9, VEE9, VGS9, VPM8, VPM9, VS19, VSD9	
	14410-Z4M-000		-	-	2	2	QX9, QXD4, QXD9, SX9, VEE9, VGS5, VS19, VSD9	
18	14791-Z0V-880	GUIDE, PUSH ROD	1	-	-	-	QX9, QXD9, SX9, VEE9, VGS9, VPM8, VPM9, VS19, VSD9	
	14791-Z4M-000	PLATE, PUSH ROD GUIDE	-	-	1	1	QX9, QXD4, QXD9, SX9, VEE9, VGS5, VS19, VSD9	
19	90413-Z0T-880	WASHER, THRUST, 14.1MM	1	-	-	-	QX9, QXD9, SX9, VEE9, VGS9, VPM8, VPM9, VS19, VSD9	

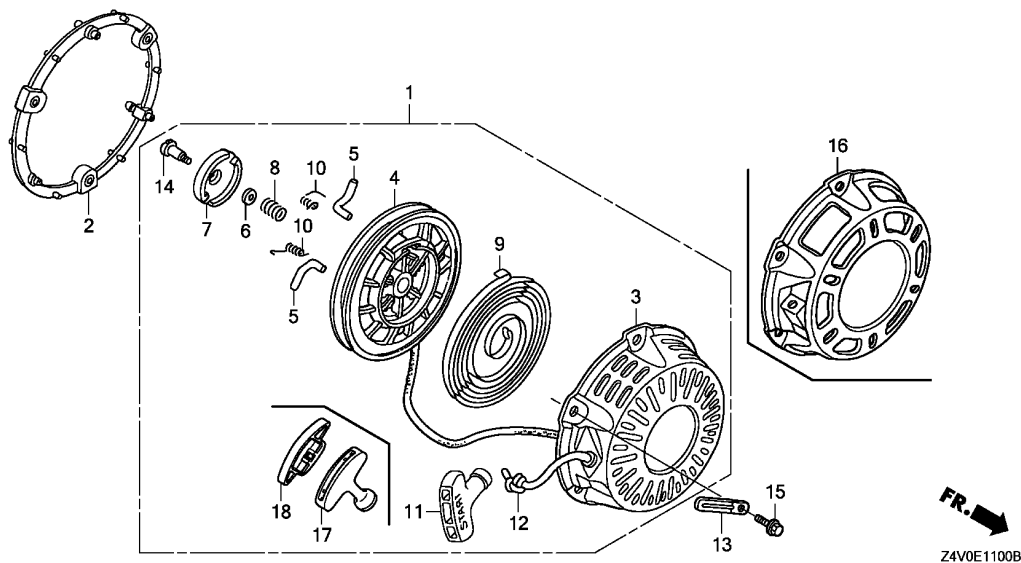

Ref. L.O.N. (Relative ref. Number) F.R.T.
No. Description

Ref. No.	Part No.	Description	Reqd. QTY				Serial No.	Parts catalogue code
			GX 200	GX 200	GX 200	GX 200		
			UT	RT	UT2	RT2		
1	28400-ZH8-023YA	STARTER ASSY., RECOIL *R280*.....POWER RED	1	1	-	-	1517328	HX2, HXU, LX2, LX4, LXAU, PXU, QG2, QH26, QH4, QHQ4, QMP4, QX2, QX26, QX4, QX7, QX9, QXB2, QXC9, QXE2, QXE4, QXE5, QXE6, QXU, RH2, RHG4, RHQ4, RMG2, RX4, RXU, SAR, SHQ4, SM12, SMC4, SX4, SX7, SX9, SXE4, SXE5, SXU, TX2, TX4, TXD1, TXDU, TXU, TXU1, VGG2, VGGN, VGS5, VGS9, VPM4, VPM8, VPM9, VS17, VS19, VSD, VSD1, VSD2, VSD7, VSD9, VX2, VX4, VXU, VXU1
	28400-ZH8-023ZB	*NH1*.....BLACK	1	1	-	-	1531504	HX2, HXU, LX2, LX4, LXAU, PXU, QG2, QH26, QH4, QHQ4, QX2, QX26, QX4, QX7, QX9, QXB2, QXC9, QXE2, QXE4, QXE6, QXU, RH2, RHQ4, RMG2, RX4, RXU, SHQ4, SM12, SMC4, SX4, SX7, SX9, TX2, TXU, TXU1, VGG2, VGGN, VSD, VSD1, VSD2, VSD7, VSD9, VX2, VX4, VXU, VXU1
	28400-ZH8-033YA	*R280*.....POWER RED	1	1	-	-	1517329	HX2, HXU, LX2, LX4, LXAU, PXU, QG2, QH26, QH4, QHQ4, QMP4, QX2, QX26, QX4, QX7, QX9, QXB2, QXC9, QXE2, QXE4, QXE5, QXE6, QXU, RH2, RHG4, RHQ4, RMG2, RX4, RXU, SAR, SHQ4, SM12, SMC4, SX4, SX7, SX9, SXE4, SXE5, SXU, TX2, TX4, TXD1, TXDU, TXU, TXU1, VGG2, VGGN, VGS5, VGS9, VPM4, VPM8, VPM9, VS17, VS19, VSD, VSD1, VSD2, VSD7, VSD9, VX2, VX4, VXU, VXU1
	28400-ZH8-033ZB	*NH1*.....BLACK	1	1	-	-	1531505	HX2, HXU, LX2, LX4, LXAU, PXU, QG2, QH26, QH4, QHQ4, QX2, QX26, QX4, QX7, QX9, QXB2, QXC9, QXE2, QXE4, QXE6, QXU, RH2, RHQ4, RMG2, RX4, RXU, SHQ4, SM12, SMC4, SX4, SX7, SX9, TX2, TXU, TXU1, VGG2, VGGN, VSD, VSD1, VSD2, VSD7, VSD9, VX2, VX4, VXU, VXU1
	28400-ZH8-033YA	*R280*.....POWER RED	1	-	-	-	-----	QXD4, QXD9, SHQ2, SMC2, VEE9
	28400-Z0T-003ZA	*NH1*.....BLACK	1	-	-	-	-----	SMCR
	28400-Z4M-305ZB	STARTER ASSY., RECOIL (COO) (FOR U.S.A.) *R280*.....POWER RED	-	-	1	1	-----	HX2, LX4, LXAU, PXU, QG2, QH26, QH4, QHQ4, QMP4, QX2, QX4, QX9, QXAG, QXB2, QXC9, QXD4, QXD9, QXE2, QXE4, QXE5, RDG4, RH2, RHG4, RHQ4, RMG2, RX4, RXU, SAR, SHQ4, SM12, SM24, SMC4, SMCR, SX4, SX9, SXE5, SXU, TX2, TXD1, TXDU, VEE9, VGGN, VGS5, VPM4, VS19, VSD9, VXU, VXU1

Ref. No.	Part No.	Description	Reqd. QTY				Serial No.	Parts catalogue code
			GX 200 UT	GX 200 RT	GX 200 UT2	GX 200 RT2		
(1)	28400-Z4M-305ZD	STARTER ASSY., RECOIL(COO) (FOR U.S.A.)						
		NH1.....BLACK	-	-	1	1	-----	HX2,LX4,PXU,QG2,QH26,QHQ4,QX2,QX4,QX9,QXB2,QXC9,QXE2,QXE4,RH2,RHQ4,RMG2,RX4,RXU,SHQ4,SM12,SM14,SMC4,SMCR,SX4,SX9,SXW9,TX2,VENN,VGGN,VSD9,VXU,VXU1
2	28405-ZLO-000ZA	SPACER, RECOIL STARTER MOUNTING						
		NH1.....BLACK	1	1	1	1	-----	HX2,HXU,LX2,LX4,PXU,QG2,QH26,QHQ4,QX2,QX26,QX4,QX7,QX9,QXB2,QXC9,QXE2,QXE4,QXE6,QXU,RH2,RHQ4,RMG2,RX4,RXU,SHQ4,SM12,SM14,SMC4,SMCR,SX4,SX7,SX9,SXW9,TX2,TXU,TXU1,VENN,VGG2,VGGN,VSD1,VSD2,VSD7,VSD9,VX2,VX4,VXU,VXU1
	28405-ZLO-000ZC	*R280R*.....POWER RED	1	1	-	1	-----	HX2,HXU,LX2,LX4,LXAU,PXU,QG2,QH26,QH4,QHQ4,QMP4,QX2,QX26,QX4,QX7,QX9,QXB2,QXC9,QXD4,QXD9,QXE2,QXE4,QXE5,QXE6,QXU,RDQ4,RH2,RHG4,RHQ4,RMG2,RX4,RXU,SAR,SHQ2,SHQ4,SM12,SMC2,SMC4,SWG4,SX4,SX7,SX9,SXE4,SXE5,SXU,TX2,TX4,TXD1,TXDU,TXU,TXU1,VEE9,VGG2,VGGN,VGS5,VGS9,VPM4,VPM8,VPM9,VS17,VS19,VSD,VSD1,VSD2,VSD7,VSD9,VX2,VX4,VXU,VXU1
			-	-	1	-	-----	HX2,LX4,LXAU,PXU,QG2,QH26,QHQ4,QMP4,QX2,QX4,QX9,QXAG,QXB2,QXC9,QXD4,QXD9,QXE2,QXE4,QXE5,RH2,RHQ4,RX4,RXU,SAR,SHQ4,SM12,SM24,SMC4,SMCR,SX4,SX9,SXE5,SXU,TX2,TXD1,TXDU,VGS5,VSD9,VXU,VXU1
3	28410-ZH8-003YA	CASE COMP., RECOIL STARTER						
		R280.....POWER RED	1	1	-	-	-----	HX2,HXU,LX2,LX4,LXAU,PXU,QG2,QH26,QH4,QHQ4,QMP4,QX2,QX26,QX4,QX7,QX9,QXB2,QXC9,QXD4,QXD9,QXE2,QXE4,QXE5,QXE6,QXU,RH2,RHG4,RHQ4,RMG2,RX4,RXU,SAR,SHQ2,SHQ4,SM12,SMC2,SMC4,SX4,SX7,SX9,SXE4,SXE5,SXU,TX2,TX4,TXD1,TXDU,TXU,TXU1,VEE9,VGG2,VGGN,VGS5,VGS9,VPM4,VPM8,VPM9,VS17,VS19,VSD,VSD1,VSD2,VSD7,VSD9,VX2,VX4,VXU,VXU1
	28410-ZH8-003ZB	*NH1*.....BLACK	1	1	-	-	-----	HX2,HXU,LX2,LX4,PXU,QG2,QH26,QHQ4,QX2,QX26,QX4,QX7,QX9,QXB2,QXC9,QXE2,QXE4,QXE6,QXU,RH2,RHQ4,RMG2,RX4,RXU,SHQ4,SM12,SMC4,SMCR,SX4,SX7,SX9,TX2,TXU,TXU1,VGG2,VGGN,VSD,VSD1,VSD2,VSD7,VSD9,VX2,VX4,VXU,VXU1
	28410-Z4M-003ZB	*R280*.....POWER RED	-	-	1	1	-----	HX2,LX4,LXAU,PXU,QG2,QH26,QHQ4,QMP4,QX2,QX4,QX9,QXAG,QXB2,QXC9,QXD4,QXD9,QXE2,QXE4,QXE5,RDQ4,RH2,RHG4,RHQ4,RMG2,RX4,RXU,SAR,SHQ4,SM12,SM24,SMC4,SMCR,SX4,SX9,SXE5,SXU,TX2,TXD1,TXDU,VEE9,VGGN,VGS5,VPM4,VS19,VSD9,VXU,VXU1
	28410-Z4M-003ZD	*NH1*.....BLACK	-	-	1	1	-----	PXU,QG2,QH26,QHQ4,QX2,QX4,QX9,QXB2,QXC9,SHQ4,SM12,SM14,SMC4,SMCR,SX4,SX9,SXW9,TX2,VENN,VGGN,VSD9,VXU,VXU1
4	28421-ZH8-801	REEL, RECOIL STARTER(BLACK)	1	1	-	-	-----	HX2,HXU,LX2,LX4,LXAU,PXU,QG2,QH26,QH4,QHQ4,QMP4,QX2,QX26,QX4,QX7,QX9,QXB2,QXC9,QXD4,QXD9,QXE2,QXE4,QXE5,QXE6,QXU,RH2,RHG4,RHQ4,RMG2,RX4,RXU,SAR,SHQ2,SHQ4,SM12,SMC2,SMC4,SX4,SX7,SX9,SXE4,SXE5,SXU,TX2,TX4,TXD1,TXDU,TXU,TXU1,VEE9,VGG2,VGGN,VGS5,VGS9,VPM4,VPM8,VPM9,VS17,VS19,VSD,VSD1,VSD2,VSD7,VSD9,VX2,VX4,VXU,VXU1
	28421-Z0T-003	REEL, RECOIL STARTER	1	-	-	-	-----	SMCR
			-	-	1	1	-----	HX2,LX4,LXAU,PXU,QG2,QH26,QHQ4,QMP4,QX2,QX4,QX9,QXAG,QXB2,QXC9,QXD4,QXD9,QXE2,QXE4,QXE5,RDQ4,RH2,RHG4,RHQ4,RMG2,RX4,RXU,SAR,SHQ4,SM12,SM14,SM24,SMC4,SMCR,SX4,SX9,SXE5,SXU,SXW9,TX2,TXD1,TXDU,VEE9,VENN,VGGN,VGS5,VPM4,VS19,VSD9,VXU,VXU1
5	28422-ZH8-801	RATCHET, STARTER	2	2	2	2	-----	HX2,HXU,LX2,LX4,LXAU,PXU,QG2,QH26,QH4,QHQ4,QMP4,QX2,QX26,QX4,QX7,QX9,QXAG,QXB2,QXC9,QXD4,QXD9,QXE2,QXE4,QXE5,QXE6,QXU,RDQ4,RH2,RHG4,RHQ4,RMG2,RX4,RXU,SAR,SHQ2,SHQ4,SM12,SM14,SM24,SMC2,SMC4,SMCR,SX4,SX7,SX9,SXE4,SXE5,SXU,SXW9,TX2,TX4,TXD1,TXDU,TXU,TXU1,VEE9,VENN,VGG2,VGGN,VGS5,VGS9,VPM4,VPM8,VPM9,VS17,VS19,VSD,VSD1,VSD2,VSD7,VSD9,VX2,VX4,VXU,VXU1



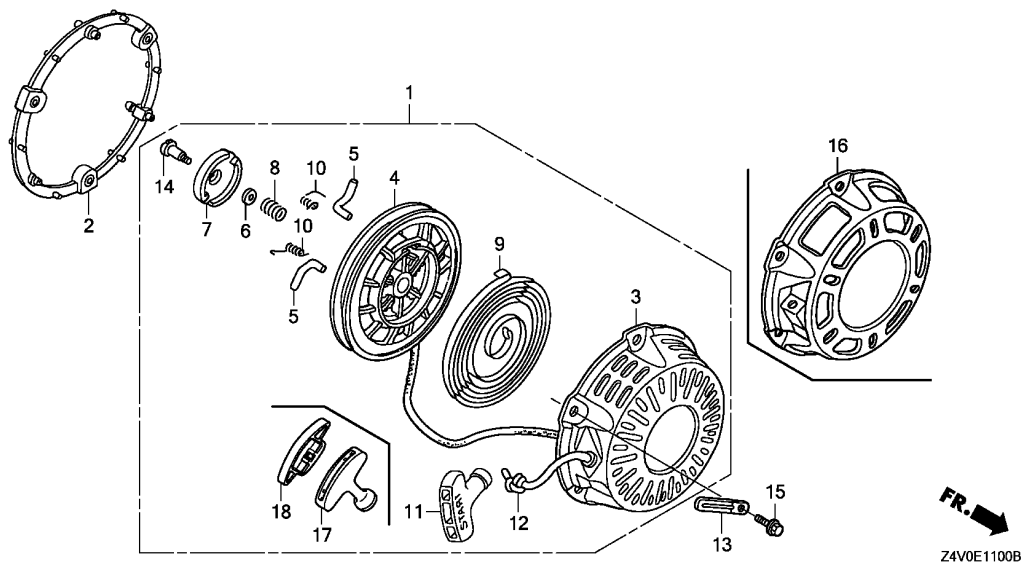

FR. →
Z4V0E1100B

Ref. No.	Part No.	Description	Reqd. QTY				Serial No.	Parts catalogue code
			GX 200 UT	GX 200 RT	GX 200 UT2	GX 200 RT2		
6	28431-ZH8-801	PLATE, FRICTION	1	1	1	1	-----	HX2,HXU,LX2,LX4,LXAU,PXU,QG2,QH26,QH4,QHQ4,QMP4,QX2,QX26,QX4,QX7,QX9,QXAG,QXB2,QXC9,QXD4,QXD9,QXE2,QXE4,QXE5,QXE6,QXU,RDG4,RH2,RHG4,RHQ4,RMG2,RX4,RXU,SAR,SHQ2,SHQ4,SM12,SM14,SM24,SMC2,SMC4,SMCR,SX4,SX7,SX9,SXE4,SXE5,SXU,SXW9, TX2, TX4, TXD1, TXDU, TXU, TXU1, VEE9, VENN, VGG2, VGGN, VGS5, VGS9, VPM4, VPM8, VPM9, VS17, VS19, VSD, VSD1, VSD2, VSD7, VSD9, VX2, VX4, VXU, VXU1
7	28433-ZH8-801	GUIDE, RATCHET	1	1	1	1	-----	HX2,HXU,LX2,LX4,LXAU,PXU,QG2,QH26,QH4,QHQ4,QMP4,QX2,QX26,QX4,QX7,QX9,QXAG,QXB2,QXC9,QXD4,QXD9,QXE2,QXE4,QXE5,QXE6,QXU,RDG4,RH2,RHG4,RHQ4,RMG2,RX4,RXU,SAR,SHQ2,SHQ4,SM12,SM14,SM24,SMC2,SMC4,SMCR,SX4,SX7,SX9,SXE4,SXE5,SXU,SXW9, TX2, TX4, TXD1, TXDU, TXU, TXU1, VEE9, VENN, VGG2, VGGN, VGS5, VGS9, VPM4, VPM8, VPM9, VS17, VS19, VSD, VSD1, VSD2, VSD7, VSD9, VX2, VX4, VXU, VXU1
8	28441-ZH8-801	SPRING, FRICTION	1	1	1	1	-----	HX2,HXU,LX2,LX4,LXAU,PXU,QG2,QH26,QH4,QHQ4,QMP4,QX2,QX26,QX4,QX7,QX9,QXAG,QXB2,QXC9,QXD4,QXD9,QXE2,QXE4,QXE5,QXE6,QXU,RDG4,RH2,RHG4,RHQ4,RMG2,RX4,RXU,SAR,SHQ2,SHQ4,SM12,SM14,SM24,SMC2,SMC4,SMCR,SX4,SX7,SX9,SXE4,SXE5,SXU,SXW9, TX2, TX4, TXD1, TXDU, TXU, TXU1, VEE9, VENN, VGG2, VGGN, VGS5, VGS9, VPM4, VPM8, VPM9, VS17, VS19, VSD, VSD1, VSD2, VSD7, VSD9, VX2, VX4, VXU, VXU1
9	28442-ZH8-003	SPRING, RECOIL STARTER	1	1	1	1	-----	HX2,HXU,LX2,LX4,LXAU,PXU,QG2,QH26,QH4,QHQ4,QMP4,QX2,QX26,QX4,QX7,QX9,QXAG,QXB2,QXC9,QXD4,QXD9,QXE2,QXE4,QXE5,QXE6,QXU,RDG4,RH2,RHG4,RHQ4,RMG2,RX4,RXU,SAR,SHQ2,SHQ4,SM12,SM14,SM24,SMC2,SMC4,SMCR,SX4,SX7,SX9,SXE4,SXE5,SXU,SXW9, TX2, TX4, TXD1, TXDU, TXU, TXU1, VEE9, VENN, VGG2, VGGN, VGS5, VGS9, VPM4, VPM8, VPM9, VS17, VS19, VSD, VSD1, VSD2, VSD7, VSD9, VX2, VX4, VXU, VXU1

Ref. No.	Part No.	Description	Reqd. QTY				Serial No.	Parts catalogue code
			GX 200 UT	GX 200 RT	GX 200 UT2	GX 200 RT2		
10	28443-ZH8-801	SPRING, RETURN	2	2	2	2	-----	HX2, HXU, LX2, LX4, LXAU, PXU, QG2, QH26, QH4, QHQ4, QMP4, QX2, QX26, QX4, QX7, QX9, QXAG, QXB2, QXC9, QXD4, QXD9, QXE2, QXE4, QXE5, QXE6, QXU, RDG4, RH2, RHG4, RHQ4, RMG2, RX4, RXU, SAR, SHQ2, SHQ4, SM12, SM14, SM24, SMC2, SMC4, SMCR, SX4, SX7, SX9, SXE4, SXE5, SXU, SXW9, TX2, TX4, TXD1, TXDU, TXU, TXU1, VEE9, VENN, VGG2, VGGN, VGS5, VGS9, VPM4, VPM8, VPM9, VS17, VS19, VSD, VSD1, VSD2, VSD7, VSD9, VX2, VX4, VXU, VXU1
11	28461-ZH8-003	GRIP, STARTER	1	1	-	-	----- 1517328	HX2, HXU, LX2, LX4, LXAU, PXU, QG2, QH26, QH4, QHQ4, QMP4, QX2, QX26, QX4, QX7, QX9, QXB2, QXC9, QXE2, QXE4, QXE5, QXE6, QXU, RH2, RHG4, RHQ4, RMG2, RX4, RXU, SAR, SHQ4, SM12, SMC4, SX4, SX7, SX9, SXE4, SXE5, SXU, TX2, TX4, TXD1, TXDU, TXU, TXU1, VGG2, VGGN, VGS5, VGS9, VPM4, VPM8, VPM9, VS17, VS19, VSD, VSD1, VSD2, VSD7, VSD9, VX2, VX4, VXU, VXU1
	28461-ZH8-013	1	1	-	-	----- 1517329	HX2, HXU, LX2, LX4, LXAU, PXU, QG2, QH26, QH4, QHQ4, QMP4, QX2, QX26, QX4, QX7, QX9, QXB2, QXC9, QXE2, QXE4, QXE5, QXE6, QXU, RH2, RHG4, RHQ4, RMG2, RX4, RXU, SAR, SHQ4, SM12, SMC4, SX4, SX7, SX9, SXE4, SXE5, SXU, TX2, TX4, TXD1, TXDU, TXU, TXU1, VGG2, VGGN, VGS5, VGS9, VPM4, VPM8, VPM9, VS17, VS19, VSD, VSD1, VSD2, VSD7, VSD9, VX2, VX4, VXU, VXU1
12	28462-ZH8-003	ROPE, RECOIL STARTER	1	1	1	1	-----	QXD4, QXD9, SHQ2, SMC2, SMCR, VEE9 HX2, HXU, LX2, LX4, LXAU, PXU, QG2, QH26, QH4, QHQ4, QMP4, QX2, QX26, QX4, QX7, QX9, QXAG, QXB2, QXC9, QXD4, QXD9, QXE2, QXE4, QXE5, QXE6, QXU, RDG4, RH2, RHG4, RHQ4, RMG2, RX4, RXU, SAR, SHQ2, SHQ4, SM12, SM14, SM24, SMC2, SMC4, SMCR, SX4, SX7, SX9, SXE4, SXE5, SXU, SXW9, TX2, TX4, TXD1, TXDU, TXU, TXU1, VEE9, VENN, VGG2, VGGN, VGS5, VGS9, VPM4, VPM8, VPM9, VS17, VS19, VSD, VSD1, VSD2, VSD7, VSD9, VX2, VX4, VXU, VXU1
13	32901-MA1-000	CLIP, SUB CORD	1	1	1	-	-----	SAR, SM12, SM14
14	90003-ZH8-801	SCREW, SETTING	1	1	1	1	-----	HX2, HXU, LX2, LX4, LXAU, PXU, QG2, QH26, QH4, QHQ4, QMP4, QX2, QX26, QX4, QX7, QX9, QXAG, QXB2, QXC9, QXD4, QXD9, QXE2, QXE4, QXE5, QXE6, QXU, RDG4, RH2, RHG4, RHQ4, RMG2, RX4, RXU, SAR, SHQ2, SHQ4, SM12, SM14, SM24, SMC2, SMC4, SMCR, SX4, SX7, SX9, SXE4, SXE5, SXU, SXW9, TX2, TX4, TXD1, TXDU, TXU, TXU1, VEE9, VENN, VGG2, VGGN, VGS5, VGS9, VPM4, VPM8, VPM9, VS17, VS19, VSD, VSD1, VSD2, VSD7, VSD9, VX2, VX4, VXU, VXU1
15	95701-06018-00	BOLT, FLANGE, 6X18	3	3	3	3		
16	28414-ZK8-V71	CASE B, STARTER	-	1	-	1	-----	SWG4
17	28461-Z4M-305	KNOB, RECOIL STARTER(COO) (FOR U.S.A.)	-	-	1	1	-----	HX2, LX4, LXAU, PXU, QG2, QH26, QHQ4, QMP4, QX2, QX4, QX9, QXAG, QXB2, QXC9, QXD4, QXD9, QXE2, QXE4, QXE5, RDG4, RH2, RHG4, RHQ4, RMG2, RX4, RXU, SAR, SHQ4, SM12, SM14, SM24, SMC4, SMCR, SX4, SX9, SXE5, SXU, SXW9, TX2, TXD1, TXDU, VEE9, VENN, VGGN, VGS5, VPM4, VS19, VSD9, VXU, VXU1
18	28463-Z4M-003	KNOB, REINFORCEMENT	-	-	1	1	-----	HX2, LX4, LXAU, PXU, QG2, QH26, QHQ4, QMP4, QX2, QX4, QX9, QXAG, QXB2, QXC9, QXD4, QXD9, QXE2, QXE4, QXE5, RDG4, RH2, RHG4, RHQ4, RMG2, RX4, RXU, SAR, SHQ4, SM12, SM14, SM24, SMC4, SMCR, SX4, SX9, SXE5, SXU, SXW9, TX2, TXD1, TXDU, VEE9, VENN, VGGN, VGS5, VPM4, VS19, VSD9, VXU, VXU1



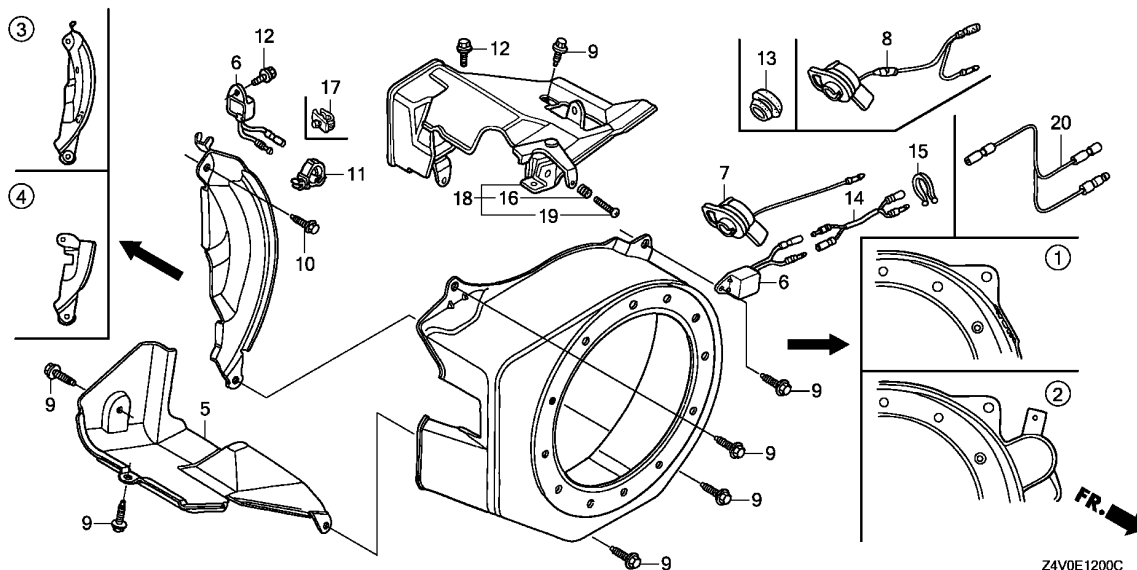

Z4V0E1200C

Ref. No.	L.O.N.	(Relative ref. Number) Description	F.R.T.
----------	--------	------------------------------------	--------

Ref. No.	Part No.	Description	Reqd. QTY				Serial No.	Parts catalogue code
			GX 200 UT	GX 200 RT	GX 200 UT2	GX 200 RT2		
1	19610-ZLO-000ZJ	COVER COMP., FAN *R280*.....POWER RED	1	1	-	-	HX2, HXU, LX2, LX4, LXAU, PXU, QG2, QH26, QHQ4, QMP4, QX2, QX26, QX4, QX7, QXB2, QXC9, QXD4, QXU, RH2, RHG4, RHQ4, RMG2, RX4, RXU, SAR, SHQ2, SHQ4, SM12, SMC2, SMC4, SX4, SX7, SXU, TX2, TX4, TXDU, TXU, VGG2, VGGN, VGS5, VPM4, VS17, VSD, VSD1, VSD2, VSD7, VX2, VX4, VXU, VXU1	
	19610-ZLO-000ZA	*NH246*.....LOOSEY GRAY	1	1	-	-	HX2, HXU, LX2, LX4, QXC9, RH2, RHQ4, RMG2, RX4, RXU	
	19610-ZLO-000ZD	*NH1*.....BLACK	1	-	-	-	PXU, QG2, QH26, QHQ4, QX2, QX26, QX4, QX7, QXB2, QXC9, QXU, SHQ4, SM12, SMC4, SMCR, SX4, SX7, TX2, TXU, VGG2, VGGN, VSD, VSD1, VSD2, VSD7, VX2, VX4, VXU, VXU1	
	19610-ZOV-880ZB	*R280*.....POWER RED	1	-	-	-	QX9, QXD9, SX9, VGS9, VPM8, VPM9, VS19, VSD9	
	19610-ZOV-880ZA	*NH1*.....BLACK	1	-	-	-	QX9, SX9, VSD9	
	19610-Z4M-000ZA	*R280*.....POWER RED	-	-	1	1	HX2, LX4, LXAU, PXU, QG2, QH26, QHQ4, QMP4, QX2, QX4, QX9, QXAG, QXB2, QXC9, QXD4, QXD9, RDG4, RH2, RHG4, RHQ4, RMG2, RX4, RXU, SAR, SHQ4, SM12, SM24, SMC4, SMCR, SX4, SX9, SXU, TX2, TXDU, VGGN, VGS5, VPM4, VS19, VSD9, VXU, VXU1	
	19610-Z4M-000ZD	*NH246*.....LOOSEY GRAY	-	-	1	1	HX2, LX4, RH2, RHQ4, RMG2, RX4, RXU	
	19610-Z4M-000ZB	*NH1*.....BLACK	-	-	1	1	PXU, QG2, QH26, QHQ4, QX2, QX4, QX9, QXB2, QXC9, SHQ4, SM12, SM14, SMC4, SMCR, SX4, SX9, SXW9, TX2, VENN, VGGN, VSD9, VXU, VXU1	
2	19610-ZLO-830ZD	COVER COMP., FAN *R280*.....POWER RED	1	-	-	-	QH4, QXE2, QXE4, QXE5, QXE6, SXE4, SXE5, TXD1, TXU1, VEE9	
	19610-ZLO-830ZA	*NH246*.....LOOSEY GRAY	1	-	-	-	QXE2, QXE4, QXE6	
	19610-ZLO-830ZE	*NH1*.....BLACK	1	-	-	-	TXU1	
	19610-ZLO-820ZF	*R280*.....POWER RED	-	1	-	-	SWG4	
	19610-Z4M-830ZB	COVER COMP., FAN (STARTER MOTOR) *R280*.....POWER RED	-	-	1	1	QXE2, QXE4, QXE5, SXE5, TXD1, VEE9	
	19610-Z4M-830ZD	*NH246*.....LOOSEY GRAY	-	-	1	-	QXE2, QXE4	
	19610-Z4M-820ZB	*R280*.....POWER RED	-	-	-	1	SWG4	

Ref. No.	Part No.	Description	Reqd. QTY				Serial No.	Parts catalogue code
			GX 200 UT	GX 200 RT	GX 200 UT2	GX 200 RT2		
3	19611-ZH8-810	PLATE COMP., SIDE(OIL ALERT)	1	1	-	-	HX2, HXU, LX2, LX4, PXU, QX2, QX26, QX4, QX7, QX9, QXC9, QXD4, QXD9, QXU, RX4, RXU, SAR, SM12, SX4, SX7, SX9, SXU, TX2, TX4, TXDU, TXU, VGG2, VGGN, VGS5, VGS9, VPM4, VPM8, VPM9, VS17, VS19, VSD, VSD1, VSD2, VSD7, VSD9, VX2, VX4, VXU, VXU1	
	19612-ZH8-000	PLATE, SIDE(STD.)	1	1	-	-	QH26, QHQ4, QMP4, QXB2, RH2, RHG4, RHQ4, SHQ2, SHQ4	
	19611-ZH8-820	PLATE COMP., SIDE (ALERT & LAMP)	1	-	-	-	LXAU, QG2, SMC2, SMC4, SMCR	
	19612-ZH8-821	PLATE, SIDE(LAMP)	-	1	-	-	RMG2	
	19611-Z4M-810	PLATE COMP., SIDE(OIL ALERT)	-	-	1	1	HX2, LX4, PXU, QX2, QX4, QX9, QXAG, QXC9, QXD4, QXD9, RX4, RXU, SAR, SM12, SM14, SM24, SX4, SX9, SXU, SXW9, TX2, TXDU, VGGN, VGS5, VPM4, VS19, VSD9, VXU, VXU1	
	19611-Z4M-820	PLATE COMP., SIDE (ALERT & LAMP)	-	-	1	1	LXAU, QG2, SMC4, SMCR, VENN	
	19612-Z4M-000	PLATE, SIDE(STD.)	-	-	1	1	QH26, QHQ4, QMP4, QXB2, RH2, RHG4, RHQ4, SHQ4	
	19612-Z4M-820	PLATE, SIDE(LAMP)	-	-	-	1	RDG4, RMG2	
4	19612-ZH8-840	PLATE, SIDE(STARTER MOTOR)	1	1	-	-	QH4, QXE2, QXE4, QXE5, QXE6, SWG4, SXE4, SXE5, TXD1, TXU1, VEE9	
	19612-Z4M-840	-	-	1	1	QXE2, QXE4, QXE5, SWG4, SXE5, TXD1, VEE9	
5	19630-ZH8-000	SHROUD COMP.	1	1	1	1	HX2, HXU, LX2, LX4, LXAU, PXU, QG2, QH26, QH4, QHQ4, QMP4, QX2, QX26, QX4, QX7, QX9, QXAG, QXB2, QXC9, QXD4, QXD9, QXE2, QXE4, QXE5, QXE6, QXU, RDG4, RH2, RHG4, RHQ4, RMG2, RX4, RXU, SAR, SHQ2, SHQ4, SM12, SM14, SM24, SMC2, SMC4, SMCR, SWG4, SX4, SX7, SX9, SXE4, SXE5, SXU, SXW9, TX2, TX4, TXD1, TXDU, TXU, TXU1, VEE9, VGG2, VGGN, VGS5, VGS9, VPM4, VPM8, VPM9, VS17, VS19, VSD, VSD1, VSD2, VSD7, VSD9, VX2, VX4, VXU, VXU1	
	19640-ZL0-V30	SHROUD COMP., LOWER	-	-	-	1	VENN	
6	34150-ZH7-013	ALERT UNIT, OIL	1	1	-	-	HX2, HXU, QXC9, QXD4, QXD9, RX4, RXU, SAR, SMC2, SMCR, SWG4, TXDU, VEE9	
	34150-ZH7-003	1	-	-	-	LX2, LX4, LXAU, PXU, QG2, QX2, QX26, QX4, QX7, QX9, QXU, SM12, SMC4, SX4, SX7, SX9, SXU, TX2, TX4, TXU, VGG2, VGGN, VGS5, VGS9, VPM4, VPM8, VPM9, VS17, VS19, VSD, VSD1, VSD2, VSD7, VSD9, VX2, VX4, VXU, VXU1	
	34150-ZH7-013	-	-	1	1	HX2, LX4, LXAU, PXU, QG2, QX2, QX4, QX9, QXAG, QXC9, QXD4, QXD9, RX4, RXU, SAR, SM12, SM14, SM24, SMC4, SMCR, SWG4, SX4, SX9, SXU, TX2, TXDU, VEE9, VENN, VGGN, VGS5, VPM4, VS19, VSD9, VXU, VXU1	
	34150-ZH7-023	-	-	1	-	SXW9	
7	35120-Z0T-801	SWITCH ASSY., ENGINE STOP	1	1	1	1	QH26, QHQ4, RDG4, RH2, RHG4, RHQ4, RMG2, SHQ2, SHQ4	
		1	-	-	-	1240212 QXB2	
8	35120-Z0T-851	SWITCH ASSY., ENGINE STOP	1	1	1	1	HX2, HXU, LX2, LX4, LXAU, PXU, QG2, QX2, QX26, QX4, QX7, QX9, QXAG, QXC9, QXD4, QXD9, QXU, RX4, RXU, SAR, SM12, SM14, SMC2, SMC4, SMCR, SX4, SX7, SX9, SXU, TX2, TX4, TXDU, TXU, VENN, VGG2, VGGN, VGS5, VGS9, VPM4, VPM8, VPM9, VS17, VS19, VSD, VSD1, VSD2, VSD7, VSD9, VX2, VX4, VXU, VXU1	
9	90013-883-000	BOLT, FLANGE, 6X12(CT200)	6	6	6	6	HX2, HXU, LX2, LX4, LXAU, PXU, QG2, QH26, QH4, QHQ4, QMP4, QX2, QX26, QX4, QX7, QX9, QXAG, QXB2, QXC9, QXD4, QXD9, QXE2, QXE4, QXE5, QXE6, QXU, RDG4, RH2, RHG4, RHQ4, RMG2, RX4, RXU, SAR, SHQ2, SHQ4, SM12, SM14, SM24, SMC2, SMC4, SMCR, SWG4, SX4, SX7, SX9, SXE4, SXE5, SXU, SXW9, TX2, TX4, TXD1, TXDU, TXU, TXU1, VEE9, VGG2, VGGN, VGS5, VGS9, VPM4, VPM8, VPM9, VS17, VS19, VSD, VSD1, VSD2, VSD7, VSD9, VX2, VX4, VXU, VXU1	
		-	-	-	8	VENN	
10	90022-888-010	BOLT, FLANGE, 6X20(CT200)	1	1	1	1	HX2, HXU, LX2, LX4, LXAU, PXU, QG2, QH26, QHQ4, QMP4, QX2, QX26, QX4, QX7, QX9, QXAG, QXB2, QXC9, QXD4, QXD9, QXU, RDG4, RH2, RHG4, RHQ4, RMG2, RX4, RXU, SAR, SHQ2, SHQ4, SM12, SM14, SM24, SMC2, SMC4, SMCR, SX4, SX7, SX9, SXU, SXW9, TX2, TX4, TXDU, TXU, VENN, VGG2, VGGN, VGS5, VGS9, VPM4, VPM8, VPM9, VS17, VS19, VSD, VSD1, VSD2, VSD7, VSD9, VX2, VX4, VXU, VXU1	
11	90601-ZH7-013	CLIP, HARNESS	1	1	1	1	HX2, HXU, LX2, LX4, LXAU, PXU, QG2, QX2, QX26, QX4, QX7, QX9, QXAG, QXC9, QXD4, QXD9, QXU, RX4, RXU, SAR, SM12, SM14, SMC2, SMC4, SMCR, SX4, SX7, SX9, SXU, SXW9, TX2, TX4, TXDU, TXU, VGG2, VGGN, VGS5, VGS9, VPM4, VPM8, VPM9, VS17, VS19, VSD, VSD1, VSD2, VSD7, VSD9, VX2, VX4, VXU, VXU1	
	90601-ZH7-D02	-	-	-	1	VENN	



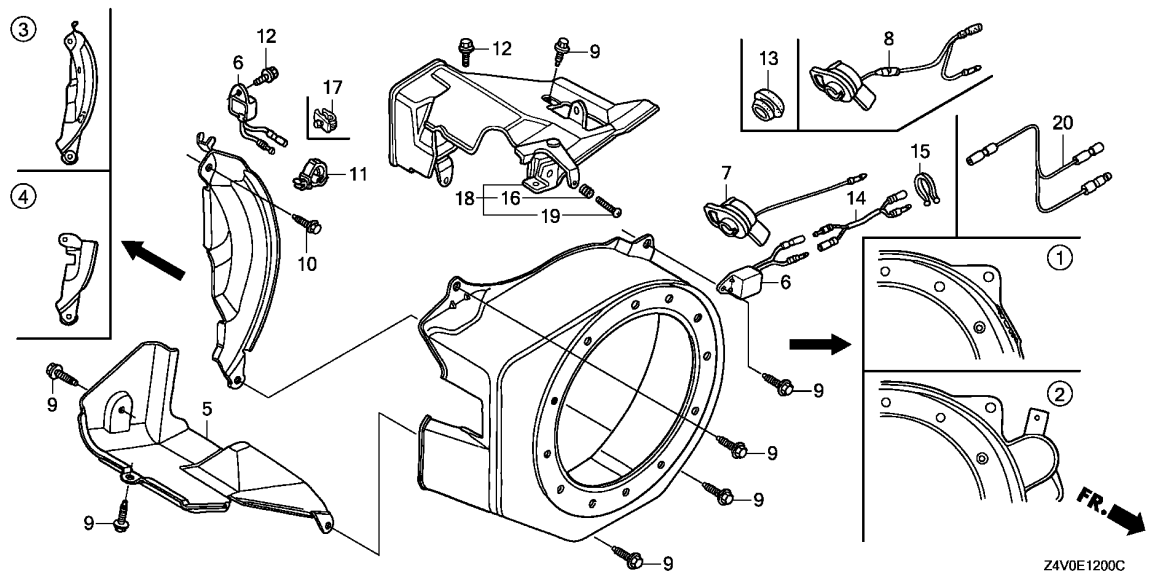

Z4V0E1200C

Ref. No.	Part No.	Description	Reqd. QTY				Serial No.	Parts catalogue code
			GX 200 UT	GX 200 RT	GX 200 UT2	GX 200 RT2		
12	95701-06008-00	BOLT, FLANGE, 6X8	1	1	1	-	HX2,HXU,LX2,LX4,LXAU,PXU,QG2,QX2,QX26,QX4,QX7,QX9,QXAG,QXC9,QXD4,QXD9,QXU,RX4,RXU,SAR,SM12,SM14,SM24,SMC2,SMC4,SMCR,SX4,SX7,SX9,SXU,SXW9, TX2, TX4, TXDU, TXU, VEE9, VGG2, VGGN, VGS5, VGS9, VPM4, VPM8, VPM9, VS17, VS19, VSD, VSD1, VSD2, VSD7, VSD9, VX2, VX4, VXU, VXU1	
			-	-	-	1	SWG4, VEE9, VGGN, VPM4, VS19	
			-	-	-	2	VENN	
13	81329-567-020	GROMMET, DRAIN HOLE	1	-	-	-	VENN	
			1	-	-	1240213	QMP4	
			-	-	1	-	QXB2	
14	32105-ZH8-V10	CABLE, DOUBLE CONNECTOR	1	1	-	1	QMP4, QXB2, SM24, SXW9	
15	90630-751-000	CLIP, PURSE LOCK	1	1	-	1	SWG4, VEE9	
			-	-	-	-	SWG4, VEE9	
16	16584-883-300	SPRING, CONTROL ADJUSTING ...	-	-	-	1	VENN	
17	19613-ZE1-020	CLAMP, CORD	-	-	1	-	SM24	
18	19620-ZL0-V30	SHROUD ASSY., UPPER	-	-	-	1	VENN	
19	93500-05035-0A	SCREW, PAN, 5X35	-	-	-	1	VENN	
20	32197-ZH8-003	SUB HARNESS	-	-	1	-	SM24	

E-14

CARBURETOR(1)

E 6

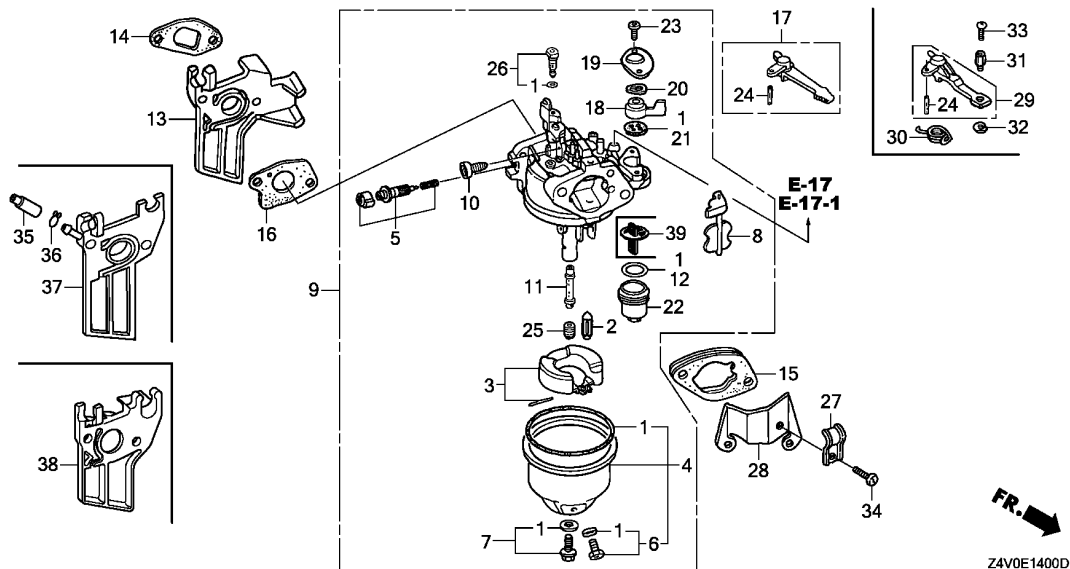

Ref. No.	L.O.N.	(Relative ref. Number) Description	F.R.T.
----------	--------	------------------------------------	--------

Ref. No.	Part No.	Description	Reqd. QTY				Serial No.	Parts catalogue code
			GX 200 UT	GX 200 RT	GX 200 UT2	GX 200 RT2		
1	16010-ZE1-812	GASKET SET	1	1	1	1	-----	HX2,HXU,LX2,LX4,LXAU,PXU,QG2,QH26,QH4,QHQ4,QMP4,QX2,QX26,QX4,QX7,QX9,QXAG,QXB2,QXC9,QXD4,QXD9,QXE2,QXE4,QXE5,QXE6,QXU,RDG4,RH2,RHG4,RHQ4,RMG2,RX4,RXU,SAR,SHQ2,SHQ4,SM12,SM14,SM24,SMC2,SMC4,SMCR,SWG4,SX4,SX7,SX9,SXE4,SXE5,SXU,SXW9,TX2,TX4,TXD1,TXDU,TXU,TXU1,VGG2,VGGN,VGS5,VGS9,VSD,VSD7,VSD9,VX2,VX4,VXU,VXU1
2	16011-ZE0-005	VALVE SET, FLOAT	1	1	1	1	-----	HX2,HXU,LX2,LX4,LXAU,PXU,QG2,QH26,QH4,QHQ4,QMP4,QX2,QX26,QX4,QX7,QX9,QXAG,QXB2,QXC9,QXD4,QXD9,QXE2,QXE4,QXE5,QXE6,QXU,RDG4,RH2,RHG4,RHQ4,RMG2,RX4,RXU,SAR,SHQ2,SHQ4,SM12,SM14,SM24,SMC2,SMC4,SMCR,SWG4,SX4,SX7,SX9,SXE4,SXE5,SXU,SXW9,TX2,TX4,TXD1,TXDU,TXU,TXU1,VGG2,VGGN,VGS5,VGS9,VSD,VSD7,VSD9,VX2,VX4,VXU,VXU1
3	16013-Z0S-B01	FLOAT SET	1	1	1	1	-----	HX2,HXU,LX2,LX4,LXAU,PXU,QG2,QH26,QH4,QHQ4,QMP4,QX2,QX26,QX4,QX7,QX9,QXAG,QXB2,QXC9,QXD4,QXD9,QXE2,QXE4,QXE5,QXE6,QXU,RDG4,RH2,RHG4,RHQ4,RMG2,RX4,RXU,SAR,SHQ2,SHQ4,SM12,SM14,SM24,SMC2,SMC4,SMCR,SWG4,SX4,SX7,SX9,SXE4,SXE5,SXU,SXW9,TX2,TX4,TXD1,TXDU,TXU,TXU1,VGG2,VGGN,VGS5,VGS9,VSD,VSD7,VSD9,VX2,VX4,VXU,VXU1
	16013-ZE0-005	1	-	-	-	-----	QH4,QXC9
4	16015-ZE0-831	CHAMBER SET, FLOAT	1	1	-	-	-----	HX2,HXU,LX2,LX4,LXAU,PXU,QG2,QH26,QH4,QHQ4,QMP4,QX2,QX26,QX4,QX7,QX9,QXB2,QXC9,QXD4,QXD9,QXE2,QXE4,QXE5,QXE6,QXU,RH2,RHG4,RHQ4,RMG2,RX4,RXU,SAR,SHQ2,SHQ4,SM12,SMC2,SMC4,SMCR,SWG4,SX4,SX7,SX9,SXE4,SXE5,SXU, TX2, TX4, TXD1, TXDU, TXU, TXU1, VGG2, VGGN, VGS5, VGS9, VSD, VSD7, VSD9, VX2, VX4, VXU, VXU1
	16015-Z4M-911	-	-	1	1	-----	HX2,LX4,LXAU,PXU,QG2,QH26,QHQ4,QMP4,QX2,QX4,QX9,QXAG,QXB2,QXC9,QXD4,QXD9,QXE2,QXE4,QXE5,RDG4,RH2,RHG4,RHQ4,RMG2,RX4,RXU,SAR,SHQ4,SM12,SM14,SM24,SMC4,SMCR,SWG4,SX4,SX9,SXE5,SXU,SXW9, TX2, TXD1, TXDU, VGGN, VGS5, VSD9, VXU, VXU1



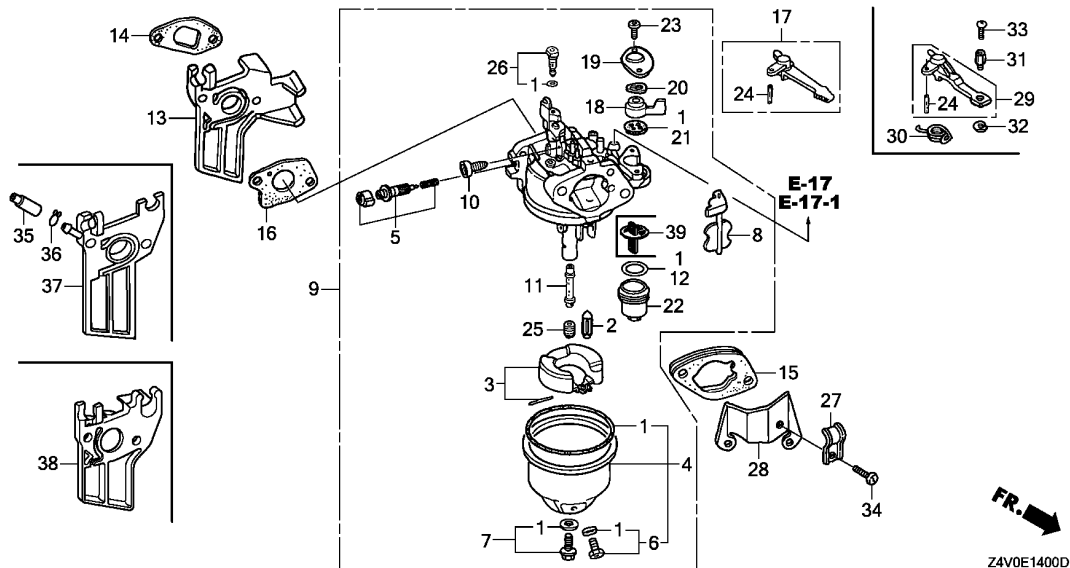

Ref. No.	Part No.	Description	Reqd. QTY				Serial No.	Parts catalogue code
			GX 200 UT	GX 200 RT	GX 200 UT2	GX 200 RT2		
5	16016-ZH7-W01	SCREW SET, PILOT	1	1	1	1	HX2, HXU, LX2, LX4, LXAU, PXU, QG2, QH26, QH4, QHQ4, QMP4, QX2, QX26, QX4, QX7, QX9, QXAG, QXB2, QXC9, QXD4, QXD9, QXE2, QXE4, QXE5, QXE6, QXU, RDG4, RH2, RHG4, RHQ4, RMG2, RX4, RXU, SAR, SHQ2, SHQ4, SM12, SM14, SM24, SMC2, SMC4, SMCR, SWG4, SX4, SX7, SX9, SXE4, SXE5, SXU, SXW9, TX2, TX4, TXD1, TXDU, TXU, TXU1, VGG2, VGGN, VGS5, VGS9, VSD, VSD7, VSD9, VX2, VX4, VXU, VXU1	
6	16024-ZE1-811	SCREW SET, DRAIN	1	1	-	-	HX2, HXU, LX2, LX4, LXAU, PXU, QG2, QH26, QH4, QHQ4, QMP4, QX2, QX26, QX4, QX7, QX9, QXB2, QXC9, QXD4, QXD9, QXE2, QXE4, QXE5, QXE6, QXU, RH2, RHG4, RHQ4, RMG2, RX4, RXU, SAR, SHQ2, SHQ4, SM12, SMC2, SMC4, SMCR, SWG4, SX4, SX7, SX9, SXE4, SXE5, SXU, TX2, TX4, TXD1, TXDU, TXU, TXU1, VGG2, VGGN, VGS5, VGS9, VSD, VSD7, VSD9, VX2, VX4, VXU, VXU1	
	16024-Z5T-901		-	-	1	1	HX2, LX4, LXAU, PXU, QG2, QH26, QH4, QHQ4, QMP4, QX2, QX4, QX9, QXAG, QXB2, QXC9, QXD4, QXD9, QXE2, QXE4, QXE5, RDG4, RH2, RHG4, RHQ4, RMG2, RX4, RXU, SAR, SHQ4, SM12, SM14, SM24, SMC4, SMCR, SWG4, SX4, SX9, SXE5, SXU, SXW9, TX2, TXD1, TXDU, VGGN, VGS5, VSD9, VXU, VXU1	
7	16028-ZE0-005	SCREW SET	1	1	-	-	HX2, HXU, LX2, LX4, LXAU, PXU, QG2, QH26, QH4, QHQ4, QMP4, QX2, QX26, QX4, QX7, QX9, QXB2, QXC9, QXD4, QXD9, QXE2, QXE4, QXE5, QXE6, QXU, RH2, RHG4, RHQ4, RMG2, RX4, RXU, SAR, SHQ2, SHQ4, SM12, SMC2, SMC4, SMCR, SWG4, SX4, SX7, SX9, SXE4, SXE5, SXU, TX2, TX4, TXD1, TXDU, TXU, TXU1, VGG2, VGGN, VGS5, VGS9, VSD, VSD7, VSD9, VX2, VX4, VXU, VXU1	
	16028-Z5T-901		-	-	1	1	HX2, LX4, LXAU, PXU, QG2, QH26, QH4, QHQ4, QMP4, QX2, QX4, QX9, QXAG, QXB2, QXC9, QXD4, QXD9, QXE2, QXE4, QXE5, RDG4, RH2, RHG4, RHQ4, RMG2, RX4, RXU, SAR, SHQ4, SM12, SM14, SM24, SMC4, SMCR, SWG4, SX4, SX9, SXE5, SXU, SXW9, TX2, TXD1, TXDU, VGGN, VGS5, VSD9, VXU, VXU1	

Ref. No.	Part No.	Description	Reqd. QTY				Serial No.	Parts catalogue code
			GX 200 UT	GX 200 RT	GX 200 UT2	GX 200 RT2		
8	16044-ZE0-005	CHOKE SET	1	1	-	-	HX2, HXU, LX2, LX4, LXAU, PXU, QG2, QH26, QH4, QHQ4, QMP4, QX2, QX26, QX4, QX7, QX9, QXB2, QXC9, QXD4, QXD9, QXE2, QXE4, QXE5, QXE6, QXU, RH2, RHG4, RHQ4, RMG2, RX4, RXU, SAR, SHQ2, SHQ4, SM12, SMC2, SMC4, SMCR, SWG4, SX4, SX7, SX9, SXE4, SXE5, SXU, TX2, TX4, TXD1, TXDU, TXU, TXU1, VGG2, VGGN, VGS5, VGS9, VSD, VSD7, VSD9, VX2, VX4, VXU, VXU1	
	16044-Z4M-911	-	-	1	1	HX2, LX4, LXAU, PXU, QG2, QH26, QH4, QX2, QX4, QX9, QXAG, QXB2, QXD4, QXD9, QXE2, QXE4, QXE5, RDG4, RH2, RHG4, RHQ4, RMG2, RX4, RXU, SAR, SHQ4, SM12, SM14, SM24, SMC4, SMCR, SWG4, SX4, SX9, SXE5, SXU, TX2, TXD1, TXDU, VGGN, VGS5, VSD9, VXU, VXU1	
	16044-ZE0-005	-	-	1	-	QMP4, QXC9, SXW9	
9	16100-Z0V-921	CARBURETOR ASSY. (BE64Y A) ...	1	1	-	-	HX2, HXU, LX2, LX4, LXAU, PXU, QG2, QH26, QH4, QX2, QX26, QX4, QX7, QX9, QXB2, QXD4, QXD9, QXE2, QXE4, QXE5, QXE6, QXU, RH2, RHG4, RHQ4, RMG2, RX4, RXU, SAR, SHQ2, SHQ4, SM12, SMC2, SMC4, SMCR, SWG4, SX4, SX7, SX9, SXE4, SXE5, SXU, TX2, TX4, TXD1, TXDU, TXU, TXU1, VGS5, VGS9, VSD, VSD7, VSD9, VX2, VX4, VXU, VXU1	
	16100-Z4V-V21	CARBURETOR ASSY. (BE59H A) ...	1	-	-	-	QH4, QXC9	
	16100-ZL0-V21	CARBURETOR ASSY. (BE64F B) ...	1	-	-	-	QH4, QXC9	
	16100-Z4V-V11	CARBURETOR ASSY. (BE59C A) ...	1	-	-	-	QMP4	
	16100-Z0V-U21	CARBURETOR ASSY. (BE64Z A) ...	1	-	-	-	VGG2, VGGN	
	16100-Z4V-921	CARBURETOR ASSY. (BE59L A) ...	-	-	1	1	HX2, LX4, LXAU, PXU, QG2, QH26, QH4, QX2, QX4, QX9, QXAG, QXB2, QXD4, QXD9, QXE2, QXE4, QXE5, RDG4, RH2, RHG4, RHQ4, RMG2, RX4, RXU, SAR, SHQ4, SM12, SM14, SM24, SMC4, SMCR, SWG4, SX4, SX9, SXE5, SXU, TX2, TXD1, TXDU, VGS5, VSD9, VXU, VXU1	
	16100-Z4V-V81	CARBURETOR ASSY. (BE59S A) ...	-	-	1	-	QMP4	
	16100-Z4V-V31	CARBURETOR ASSY. (BE59R A) ...	-	-	1	-	QXC9, SXW9	
	16100-Z4V-U32	CARBURETOR ASSY. (BE59P A) ...	-	-	-	1	VGGN	
10	16124-ZE0-005	SCREW, THROTTLE STOP	1	1	1	1	HX2, HXU, LX2, LX4, LXAU, PXU, QG2, QH26, QH4, QHQ4, QMP4, QX2, QX26, QX4, QX7, QX9, QXAG, QXB2, QXC9, QXD4, QXD9, QXE2, QXE4, QXE5, QXE6, QXU, RDG4, RH2, RHG4, RHQ4, RMG2, RX4, RXU, SAR, SHQ2, SHQ4, SM12, SM14, SM24, SMC2, SMC4, SMCR, SWG4, SX4, SX7, SX9, SXE4, SXE5, SXU, SXW9, TX2, TX4, TXD1, TXDU, TXU, TXU1, VGG2, VGGN, VGS5, VGS9, VSD, VSD7, VSD9, VX2, VX4, VXU, VXU1	
11	16166-ZL0-000	NOZZLE, MAIN	1	1	-	-	HX2, HXU, LX2, LX4, LXAU, PXU, QG2, QH26, QH4, QHQ4, QMP4, QX2, QX26, QX4, QX7, QX9, QXB2, QXD4, QXD9, QXE2, QXE4, QXE5, QXE6, QXU, RH2, RHG4, RHQ4, RMG2, RX4, RXU, SAR, SHQ2, SHQ4, SM12, SMC2, SMC4, SMCR, SWG4, SX4, SX7, SX9, SXE4, SXE5, SXU, TX2, TX4, TXD1, TXDU, TXU, TXU1, VGG2, VGGN, VGS5, VGS9, VSD, VSD7, VSD9, VX2, VX4, VXU, VXU1	
	16166-ZL0-V20	1	-	1	-	QH4, QXC9, SXW9	
	16166-Z4V-921	-	-	1	1	HX2, LX4, LXAU, PXU, QG2, QH26, QH4, QX2, QX4, QX9, QXAG, QXB2, QXD4, QXD9, QXE2, QXE4, QXE5, RDG4, RH2, RHG4, RHQ4, RMG2, RX4, RXU, SAR, SHQ4, SM12, SM14, SM24, SMC4, SMCR, SWG4, SX4, SX9, SXE5, SXU, TX2, TXD1, TXDU, VGGN, VGS5, VSD9, VXU, VXU1	
	16166-ZL0-000	-	-	1	-	QMP4	
12	16173-001-004	PACKING, FUEL STRAINER CUP ..	1	1	1	1	HX2, HXU, LX2, LX4, LXAU, PXU, QG2, QH26, QH4, QHQ4, QMP4, QX2, QX26, QX4, QX7, QX9, QXAG, QXB2, QXC9, QXD4, QXD9, QXE2, QXE4, QXE5, QXE6, QXU, RDG4, RH2, RHG4, RHQ4, RMG2, RX4, RXU, SAR, SHQ2, SHQ4, SM12, SM14, SM24, SMC2, SMC4, SMCR, SWG4, SX4, SX7, SX9, SXE4, SXE5, SXU, SXW9, TX2, TX4, TXD1, TXDU, TXU, TXU1, VGG2, VGGN, VGS5, VGS9, VSD, VSD7, VSD9, VX2, VX4, VXU, VXU1	
13	16211-ZL0-000	INSULATOR, CARBURETOR	1	1	-	-	HX2, HXU, LX2, LX4, LXAU, PXU, QG2, QH26, QH4, QHQ4, QMP4, QX2, QX26, QX4, QX7, QX9, QXB2, QXC9, QXD4, QXD9, QXE2, QXE4, QXE5, QXE6, QXU, RH2, RHG4, RHQ4, RMG2, RX4, RXU, SAR, SHQ2, SHQ4, SM12, SMC2, SMC4, SMCR, SWG4, SX4, SX7, SX9, SXE4, SXE5, SXU, TX2, TX4, TXD1, TXDU, TXU, TXU1, VGG2, VGGN, VGS5, VGS9, VSD, VSD7, VSD9, VX2, VX4, VXU, VXU1	



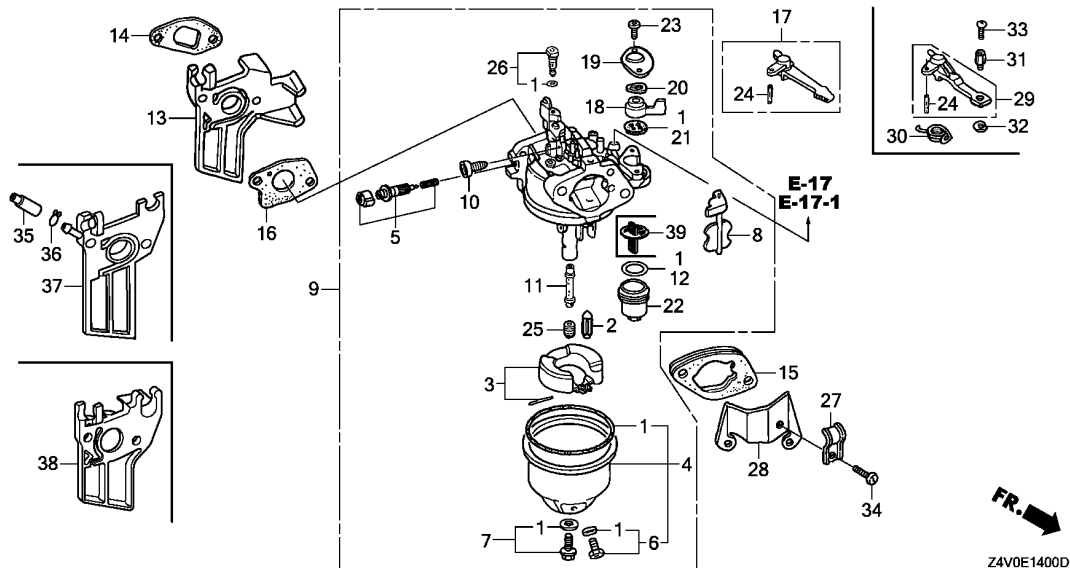

Ref. No.	Part No.	Description	Reqd. QTY				Serial No.	Parts catalogue code
			GX 200 UT	GX 200 RT	GX 200 UT2	GX 200 RT2		
14	16212-ZH8-800	PACKING, INSULATOR	1	1	1	1	-----	HX2, HXU, LX2, LX4, LXAU, PXU, QG2, QH26, QH4, QHQ4, QMP4, QX2, QX26, QX4, QX7, QX9, QXAG, QXB2, QXC9, QXD4, QXD9, QXE2, QXE4, QXE5, QXE6, QXU, RDG4, RH2, RHG4, RHQ4, RMG2, RX4, RXU, SAR, SHQ2, SHQ4, SM12, SM14, SM24, SMC2, SMC4, SMCR, SWG4, SX4, SX7, SX9, SXE4, SXE5, SXU, SXW9, TX2, TX4, TXD1, TXDU, TXU, TXU1, VGG2, VGGN, VGS5, VGS9, VSD, VSD7, VSD9, VX2, VX4, VXU, VXU1
15	16220-ZE1-020	SPACER COMP., CARBURETOR	1	1	1	1	-----	HX2, HXU, LX2, LX4, LXAU, PXU, QG2, QH26, QH4, QHQ4, QMP4, QX2, QX26, QX4, QX7, QX9, QXAG, QXB2, QXC9, QXD4, QXD9, QXE2, QXE4, QXE5, QXE6, QXU, RDG4, RH2, RHG4, RHQ4, RMG2, RX4, RXU, SAR, SHQ2, SHQ4, SM12, SM14, SM24, SMC2, SMC4, SMCR, SWG4, SX4, SX7, SX9, SXE4, SXE5, SXU, SXW9, TX2, TX4, TXD1, TXDU, TXU, TXU1, VGG2, VGGN, VGS5, VGS9, VSD, VSD7, VSD9, VX2, VX4, VXU, VXU1
16	16221-ZH8-801	PACKING, CARBURETOR	1	1	1	1	-----	HX2, HXU, LX2, LX4, LXAU, PXU, QG2, QH26, QH4, QHQ4, QMP4, QX2, QX26, QX4, QX7, QX9, QXAG, QXB2, QXC9, QXD4, QXD9, QXE2, QXE4, QXE5, QXE6, QXU, RDG4, RH2, RHG4, RHQ4, RMG2, RX4, RXU, SAR, SHQ2, SHQ4, SM12, SM14, SM24, SMC2, SMC4, SMCR, SWG4, SX4, SX7, SX9, SXE4, SXE5, SXU, SXW9, TX2, TX4, TXD1, TXDU, TXU, TXU1, VGG2, VGGN, VGS5, VGS9, VSD, VSD7, VSD9, VX2, VX4, VXU, VXU1
17	16610-ZE1-000	LEVER COMP., CHOKE(STD.)	1	1	1	1	-----	HX2, HXU, LX2, LX4, LXAU, PXU, QG2, QH26, QH4, QHQ4, QMP4, QX2, QX26, QX4, QX7, QX9, QXAG, QXB2, QXC9, QXD4, QXD9, QXE2, QXE4, QXE5, QXE6, QXU, RDG4, RH2, RHG4, RHQ4, RMG2, RX4, RXU, SAR, SHQ2, SHQ4, SM12, SM14, SM24, SMC2, SMC4, SMCR, SX4, SX7, SX9, SXE4, SXE5, SXU, SXW9, TX2, TX4, TXD1, TXDU, TXU, TXU1, VGG2, VGGN, VGS5, VGS9, VSD, VSD7, VSD9, VX2, VX4, VXU, VXU1

Ref. No.	Part No.	Description	Reqd. QTY				Serial No.	Parts catalogue code
			GX 200 UT	GX 200 RT	GX 200 UT2	GX 200 RT2		
18	16953-ZE1-812	LEVER, COCK	1	1	1	1	-----	HX2, HXU, LX2, LX4, LXAU, PXU, QG2, QH26, QH4, QHQ4, QMP4, QX2, QX26, QX4, QX7, QX9, QXAG, QXB2, QXC9, QXD4, QXD9, QXE2, QXE4, QXE5, QXE6, QXU, RDG4, RH2, RHG4, RHQ4, RMG2, RX4, RXU, SAR, SHQ2, SHQ4, SM12, SM14, SM24, SMC2, SMC4, SMCR, SWG4, SX4, SX7, SX9, SXE4, SXE5, SXU, SXW9, TX2, TX4, TXD1, TXDU, TXU, TXU1, VGG2, VGGN, VGS5, VGS9, VSD, VSD7, VSD9, VX2, VX4, VXU, VXU1
19	16954-ZE1-812	PLATE, LEVER SETTING	1	1	1	1	-----	HX2, HXU, LX2, LX4, LXAU, PXU, QG2, QH26, QH4, QHQ4, QMP4, QX2, QX26, QX4, QX7, QX9, QXAG, QXB2, QXC9, QXD4, QXD9, QXE2, QXE4, QXE5, QXE6, QXU, RDG4, RH2, RHG4, RHQ4, RMG2, RX4, RXU, SAR, SHQ2, SHQ4, SM12, SM14, SM24, SMC2, SMC4, SMCR, SWG4, SX4, SX7, SX9, SXE4, SXE5, SXU, SXW9, TX2, TX4, TXD1, TXDU, TXU, TXU1, VGG2, VGGN, VGS5, VGS9, VSD, VSD7, VSD9, VX2, VX4, VXU, VXU1
20	16956-ZE1-811	SPRING, COCK LEVER	1	1	1	1	-----	HX2, HXU, LX2, LX4, LXAU, PXU, QG2, QH26, QH4, QHQ4, QMP4, QX2, QX26, QX4, QX7, QX9, QXAG, QXB2, QXC9, QXD4, QXD9, QXE2, QXE4, QXE5, QXE6, QXU, RDG4, RH2, RHG4, RHQ4, RMG2, RX4, RXU, SAR, SHQ2, SHQ4, SM12, SM14, SM24, SMC2, SMC4, SMCR, SWG4, SX4, SX7, SX9, SXE4, SXE5, SXU, SXW9, TX2, TX4, TXD1, TXDU, TXU, TXU1, VGG2, VGGN, VGS5, VGS9, VSD, VSD7, VSD9, VX2, VX4, VXU, VXU1
21	16957-ZE1-812	PACKING, FUEL COCK	1	1	1	1	-----	HX2, HXU, LX2, LX4, LXAU, PXU, QG2, QH26, QH4, QHQ4, QMP4, QX2, QX26, QX4, QX7, QX9, QXAG, QXB2, QXC9, QXD4, QXD9, QXE2, QXE4, QXE5, QXE6, QXU, RDG4, RH2, RHG4, RHQ4, RMG2, RX4, RXU, SAR, SHQ2, SHQ4, SM12, SM14, SM24, SMC2, SMC4, SMCR, SWG4, SX4, SX7, SX9, SXE4, SXE5, SXU, SXW9, TX2, TX4, TXD1, TXDU, TXU, TXU1, VGG2, VGGN, VGS5, VGS9, VSD, VSD7, VSD9, VX2, VX4, VXU, VXU1
22	16967-ZE0-811	CUP, FUEL STRAINER	1	1	1	1	-----	HX2, HXU, LX2, LX4, LXAU, PXU, QG2, QH26, QH4, QHQ4, QMP4, QX2, QX26, QX4, QX7, QX9, QXAG, QXB2, QXC9, QXD4, QXD9, QXE2, QXE4, QXE5, QXE6, QXU, RDG4, RH2, RHG4, RHQ4, RMG2, RX4, RXU, SAR, SHQ2, SHQ4, SM12, SM14, SM24, SMC2, SMC4, SMCR, SWG4, SX4, SX7, SX9, SXE4, SXE5, SXU, SXW9, TX2, TX4, TXD1, TXDU, TXU, TXU1, VGG2, VGGN, VGS5, VGS9, VSD, VSD7, VSD9, VX2, VX4, VXU, VXU1
23	93500-03006-1H	SCREW, PAN, 3X6	2	2	2	2	-----	HX2, HXU, LX2, LX4, LXAU, PXU, QG2, QH26, QH4, QHQ4, QMP4, QX2, QX26, QX4, QX7, QX9, QXAG, QXB2, QXC9, QXD4, QXD9, QXE2, QXE4, QXE5, QXE6, QXU, RDG4, RH2, RHG4, RHQ4, RMG2, RX4, RXU, SAR, SHQ2, SHQ4, SM12, SM14, SM24, SMC2, SMC4, SMCR, SWG4, SX4, SX7, SX9, SXE4, SXE5, SXU, SXW9, TX2, TX4, TXD1, TXDU, TXU, TXU1, VGG2, VGGN, VGS5, VGS9, VSD, VSD7, VSD9, VX2, VX4, VXU, VXU1
24	94305-20122	PIN, SPRING, 2X12	1	1	1	1	-----	HX2, HXU, LX2, LX4, LXAU, PXU, QG2, QH26, QH4, QHQ4, QMP4, QX2, QX26, QX4, QX7, QX9, QXAG, QXB2, QXC9, QXD4, QXD9, QXE2, QXE4, QXE5, QXE6, QXU, RDG4, RH2, RHG4, RHQ4, RMG2, RX4, RXU, SAR, SHQ2, SHQ4, SM12, SM14, SM24, SMC2, SMC4, SMCR, SWG4, SX4, SX7, SX9, SXE4, SXE5, SXU, SXW9, TX2, TX4, TXD1, TXDU, TXU, TXU1, VGG2, VGGN, VGS5, VGS9, VSD, VSD7, VSD9, VX2, VX4, VXU, VXU1
25	99101-ZH8-0700	JET, MAIN, #70	(1)	(1)	(1)	(1)	-----	HX2, HXU, LX2, LX4, LXAU, PXU, QG2, QH26, QH4, QHQ4, QMP4, QX2, QX26, QX4, QX7, QX9, QXAG, QXB2, QXC9, QXD4, QXD9, QXE2, QXE4, QXE5, QXE6, QXU, RDG4, RH2, RHG4, RHQ4, RMG2, RX4, RXU, SAR, SHQ2, SHQ4, SM12, SM14, SM24, SMC2, SMC4, SMCR, SWG4, SX4, SX7, SX9, SXE4, SXE5, SXU, SXW9, TX2, TX4, TXD1, TXDU, TXU, TXU1, VGG2, VGGN, VGS5, VGS9, VSD, VSD7, VSD9, VX2, VX4, VXU, VXU1
	99101-ZH8-0680	JET, MAIN, #68	(1)	(1)	(1)	(1)	-----	HX2, HXU, LX2, LX4, LXAU, PXU, QG2, QH26, QH4, QX2, QX26, QX4, QX7, QX9, QXB2, QXD4, QXD9, QXE2, QXE4, QXE5, QXE6, QXU, RH2, RHG4, RHQ4, RMG2, RX4, RXU, SAR, SHQ2, SHQ4, SM12, SM14, SM24, SMC2, SMC4, SMCR, SWG4, SX4, SX7, SX9, SXE4, SXE5, SXU, TX2, TX4, TXD1, TXDU, TXU, TXU1, VGG2, VGGN, VGS5, VGS9, VSD, VSD7, VSD9, VX2, VX4, VXU, VXU1

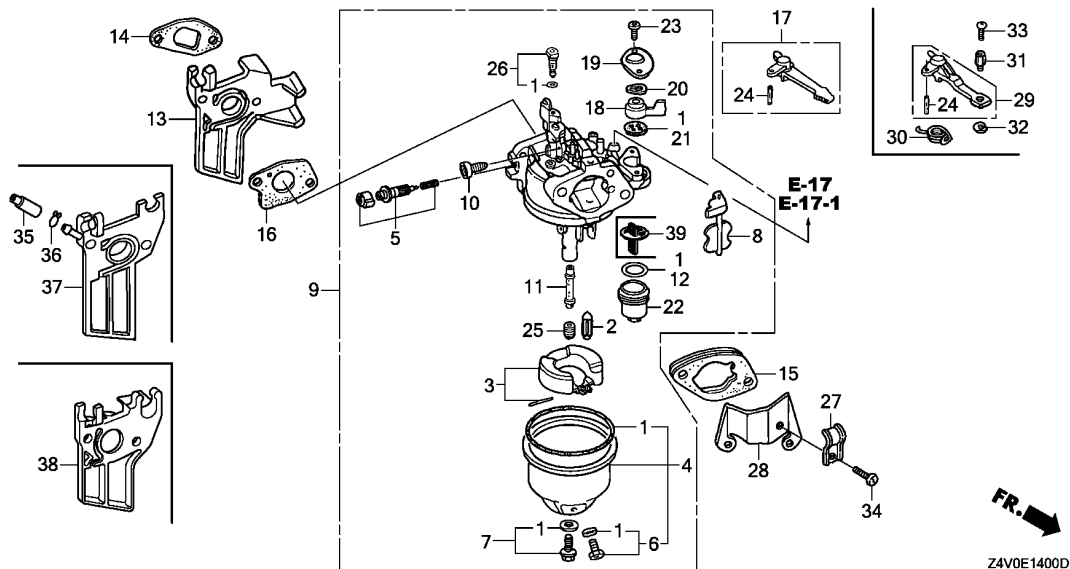

Ref. No.	Part No.	Description	Reqd. QTY				Serial No.	Parts catalogue code
			GX 200 UT RT	GX 200 RT UT2	GX 200 UT2	GX 200 RT2		
25)	99101-ZH8-0720	JET, MAIN, #72	1	1	-	-	-----	HX2,HXU,LX2,LX4,LXAU,PXU,QG2,QH26,QHQ4,QX2,QX26,QX4,QX7,QX9 QXB2,QXD4,QXD9,QXE2,QXE4,QXE5,QXE6,QXU,RH2,RHG4,RHQ4,RMG2,RX4 RXU,SAR,SHQ2,SHQ4,SM12,SMC2,SMC4,SMCR,SWG4,SX4,SX7,SX9,SXE4 SXE5,SXU,TX2,TX4,TXD1,TXDU,TXU,TXU1,VGG2,VGGN,VGS5,VGS9,VSD VSD7,VSD9,VX2,VX4,VXU,VXU1
	99101-ZH8-0750	JET, MAIN, #75	(1)	-	-	-	-----	QH4,QMP4,QXC9
			1	-	-	-	-----	QH4,QMP4,QXC9
			-	-	1	1	-----	HX2,LX4,LXAU,PXU,QG2,QH26,QHQ4,QMP4,QX2,QX4,QX9,QXAG,QXB2,QXC9 QXD4,QXD9,QXE2,QXE4,QXE5,RDG4,RH2,RHG4,RHQ4,RMG2,RX4,RXU,SAR SHQ4,SM12,SM14,SM24,SMC4,SMCR,SWG4,SX4,SX9,SXE5,SXU,SXW9,TX2 TXD1,TXDU,VGGN,VGS5,VSD9,VXU,VXU1
	99101-ZH8-0720	JET, MAIN, #72	-	-	(1)	(1)	-----	HX2,LX4,PXU,QG2,QH26,QHQ4,QMP4,QX2,QX4,QX9,QXAG,QXC9,QXD4,QXD9 QXE2,QXE4,RDG4,RH2,RHG4,RHQ4,RMG2,RX4,RXU,SHQ4,SM12,SM14,SM24 SMCR,SWG4,SX4,SX9,SXU,SXW9,TX2,VGGN,VGS5,VSD9,VXU
26	99204-ZA0-0450	JET SET, PILOT, #45	1	1	-	-	-----	HX2,HXU,LX2,LX4,LXAU,PXU,QG2,QH26,QH4,QHQ4,QMP4,QX2,QX26,QX4 QX7,QX9,QXB2,QXC9,QXD4,QXD9,QXE2,QXE4,QXE5,QXE6,QXU,RH2,RHG4 RHQ4,RMG2,RX4,RXU,SAR,SHQ2,SHQ4,SM12,SMC2,SMC4,SMCR,SWG4,SX4 SX7,SX9,SXE4,SXE5,SXU,TX2,TX4,TXD1,TXDU,TXU,TXU1,VGG2,VGGN VGS5,VGS9,VSD,VSD7,VSD9,VX2,VX4,VXU,VXU1
	99204-ZE2-0400	JET SET, PILOT, #40	-	-	1	1	-----	HX2,LX4,LXAU,PXU,QG2,QH26,QHQ4,QX2,QX4,QX9,QXAG,QXB2,QXD4,QXD9 QXE2,QXE4,QXE5,RDG4,RH2,RHG4,RHQ4,RMG2,RX4,RXU,SAR,SHQ4,SM12 SM14,SM24,SMC4,SMCR,SWG4,SX4,SX9,SXE5,SXU,TX2,TXD1,TXDU,VGGN VGS5,VSD9,VXU,VXU1
	99204-ZA0-0450	JET SET, PILOT, #45	-	-	1	-	-----	QMP4,QXC9,SXW9
27	16582-883-300	HOLDER, CONTROL CABLE	1	1	-	1	-----	QH4,SWG4
28	16598-ZE1-000	STAY, CHOKE CONTROL	1	1	-	1	-----	QH4,SWG4
29	16610-ZE1-810	LEVER COMP., CHOKE(REMOTE)	1	1	-	1	-----	QH4,SWG4
30	16615-ZE1-010	SPRING, RETURN	1	1	-	1	-----	QH4,SWG4

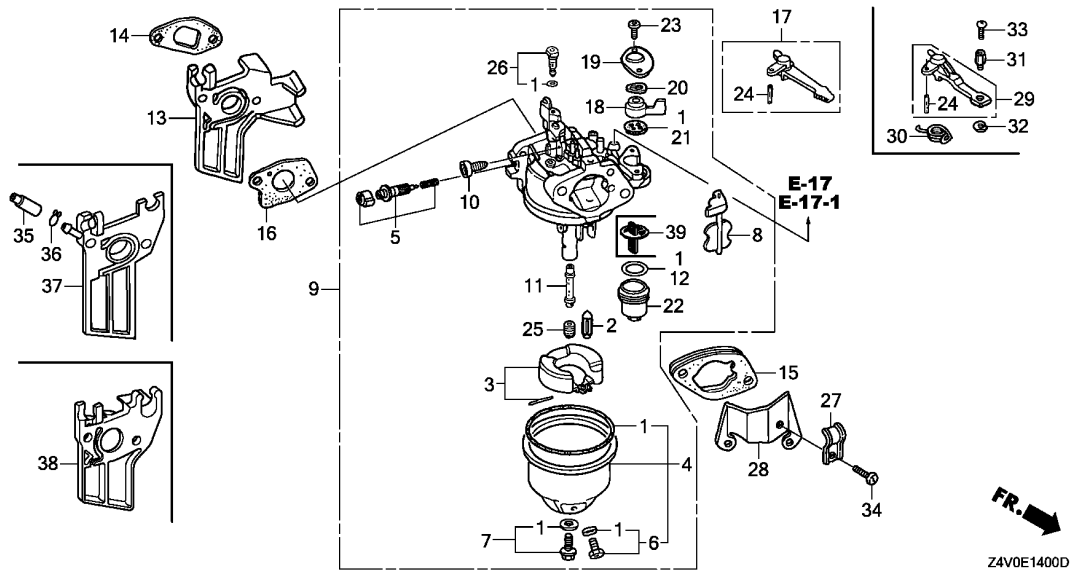

Ref. No.	Part No.	Description	Reqd. QTY				Serial No.	Parts catalogue code
			GX 200 UT	GX 200 RT	GX 200 UT2	GX 200 RT2		
31	16617-890-010	HOLDER, CABLE	1	1	-	1	-----	QH4, SWG4
32	90605-230-000	CIRCLIP, 5MM	1	1	-	1	-----	QH4, SWG4
33	93500-04008-0A	SCREW, PAN, 4X8	1	1	-	1	-----	QH4, SWG4
34	93500-05008-0A	SCREW, PAN, 5X8	1	1	-	1	-----	QH4, SWG4
35	16215-MV4-000	CAP, BOOST	-	-	1	-	-----	QMP4
36	95002-02070	CLIP, TUBE(B7)	-	-	1	-	-----	QMP4
37	16210-Z4V-800	INSULATOR COMP., CARBURETOR	-	-	1	-	-----	QMP4
38	16211-Z4V-000	INSULATOR, CARBURETOR	-	-	1	1	-----	HX2, LX4, LXAU, PXU, QG2, QH26, QHQ4, QX2, QX4, QX9, QXAG, QXB2, QXC9, QXD4, QXD9, QXE2, QXE4, QXE5, RDG4, RH2, RHG4, RHQ4, RMG2, RX4, RXU, SAR, SHQ4, SM12, SM14, SM24, SMC4, SMCR, SWG4, SX4, SX9, SXE5, SXU, SXW9, TX2, TXD1, TXDU, VGGN, VGS5, VSD9, VXU, VXU1
39	16959-Z5T-901	FILTER, CUP	-	-	1	1	-----	HX2, LX4, LXAU, PXU, QG2, QH26, QHQ4, QMP4, QX2, QX4, QX9, QXAG, QXB2, QXC9, QXD4, QXD9, QXE2, QXE4, QXE5, RDG4, RH2, RHG4, RHQ4, RMG2, RX4, RXU, SAR, SHQ4, SM12, SM14, SM24, SMC4, SMCR, SWG4, SX4, SX9, SXE5, SXU, SXW9, TX2, TXD1, TXDU, VGGN, VGS5, VSD9, VXU, VXU1



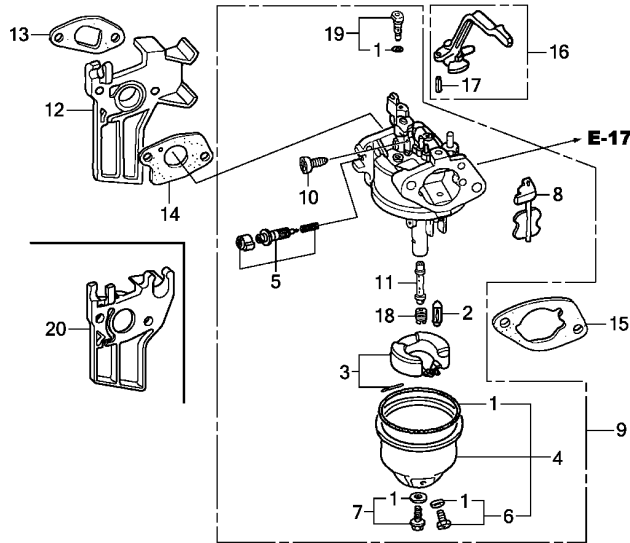

Ref. No.	L.O.N.	(Relative ref. Number) Description	F.R.T.
----------	--------	------------------------------------	--------

Ref. No.	Part No.	Description	Reqd. QTY				Serial No.	Parts catalogue code
			GX 200 UT	GX 200 RT	GX 200 UT2	GX 200 RT2		
1	16010-ZB1-015	GASKET SET	1	-	-	1	VEE9,VENN,VPM4,VPM8,VPM9,VS17,VS19,VSD1,VSD2	
2	16011-ZE0-005	VALVE SET, FLOAT	1	-	-	1	VEE9,VENN,VPM4,VPM8,VPM9,VS17,VS19,VSD1,VSD2	
3	16013-Z0S-B01	FLOAT SET	1	-	-	1	VEE9,VENN,VPM4,VPM8,VPM9,VS17,VS19,VSD1,VSD2	
4	16015-ZE0-831	CHAMBER SET, FLOAT	1	-	-	1	VEE9,VPM4,VPM8,VPM9,VS17,VS19,VSD1,VSD2	
	16015-Z4M-911	-	-	-	1	VEE9,VENN,VPM4,VS19	
5	16016-ZH7-W01	SCREW SET, PILOT	1	-	-	1	VEE9,VENN,VPM4,VPM8,VPM9,VS17,VS19,VSD1,VSD2	
6	16024-ZE1-811	SCREW SET, DRAIN	1	-	-	-	VEE9,VPM4,VPM8,VPM9,VS17,VS19,VSD1,VSD2	
	16024-Z5T-901	-	-	-	1	VEE9,VENN,VPM4,VS19	
7	16028-ZE0-005	SCREW SET	1	-	-	-	VEE9,VPM4,VPM8,VPM9,VS17,VS19,VSD1,VSD2	
	16028-Z5T-901	-	-	-	1	VEE9,VENN,VPM4,VS19	
8	16044-ZE0-005	CHOKE SET	1	-	-	1	VEE9,VENN,VPM4,VPM8,VPM9,VS17,VS19,VSD1,VSD2	
9	16100-Z4V-U91	CARBURETOR ASSY.(BE74Q A) ...	1	-	-	-	VEE9	
	16100-Z0V-U92	CARBURETOR ASSY.(BE74K B) ...	1	-	-	-	1085295 VS17,VS19,VSD1	
	16100-Z0V-U51	CARBURETOR ASSY.(BE74J A) ...	1	-	-	-	1085295 VSD2	
			1	-	-	-	1104342 VPM4,VPM9	
			1	-	-	-	1104342 VPM8	
	16100-Z0V-U92	CARBURETOR ASSY.(BE74K B) ...	1	-	-	-	1085296 VS17,VS19,VSD1	
	16100-Z4V-U91	CARBURETOR ASSY.(BE74Q A) ...	1	-	-	-	1085296 VSD2	
	16100-Z4V-U51	CARBURETOR ASSY.(BE74P A) ...	1	-	-	-	1104343 VPM4,VPM9	
			1	-	-	-	1104343 VPM8	
	16100-Z4V-U91	CARBURETOR ASSY.(BE74Q A) ...	1	-	-	-	VEE9,VS19	
	16100-Z4V-V41	CARBURETOR ASSY.(BE74V A) ...	-	-	-	1	VENN,VPM4	
	16100-Z4V-U01	CARBURETOR ASSY.(BE74Z A) ...	-	-	-	1	VEE9,VENN,VPM4,VPM8,VPM9,VS17,VS19,VSD1,VSD2	
10	16124-ZE0-005	SCREW, THROTTLE STOP	1	-	-	1	VEE9,VENN,VPM4,VPM8,VPM9,VS17,VS19,VSD1,VSD2	
11	16166-ZL0-000	NOZZLE, MAIN	1	-	-	1	VEE9,VENN,VPM4,VPM8,VPM9,VS17,VS19,VSD1,VSD2	
12	16211-ZL0-000	INSULATOR, CARBURETOR	1	-	-	-	VEE9,VPM4,VPM8,VPM9,VS17,VS19,VSD1,VSD2	
13	16212-ZH8-800	PACKING, INSULATOR	1	-	-	1	VEE9,VENN,VPM4,VPM8,VPM9,VS17,VS19,VSD1,VSD2	
14	16221-ZH8-801	PACKING, CARBURETOR	1	-	-	1	VEE9,VENN,VPM4,VPM8,VPM9,VS17,VS19,VSD1,VSD2	

2

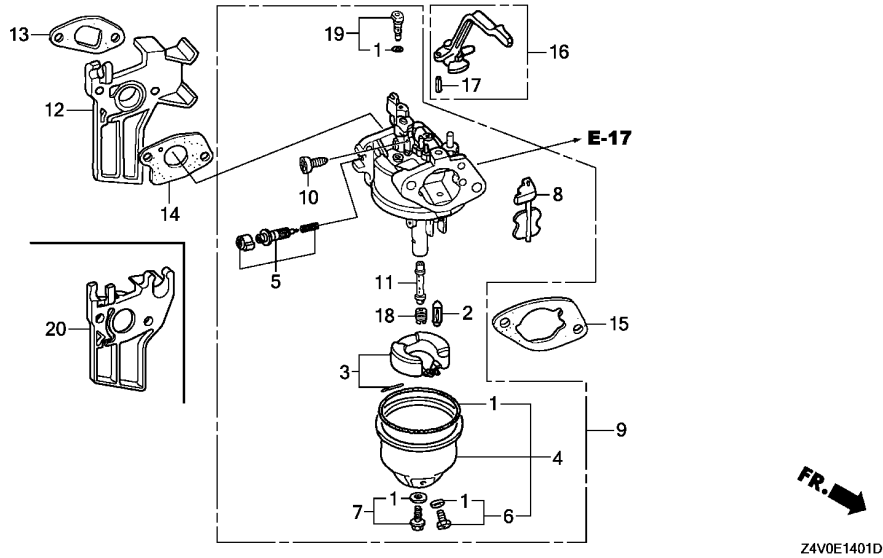

Ref. No.	Part No.	Description	Reqd. QTY				Serial No.	Parts catalogue code
			GX 200 UT	GX 200 RT	GX 200 UT2	GX 200 RT2		
15	16269-ZE1-800	PACKING, AIR CLEANER	1	-	-	1	-----	VEE9,VENN,VPM4,VPM8,VPM9,VS17,VS19,VSD1,VSD2
16	16610-ZB2-000	LEVER COMP., CHOKE	1	-	-	1	-----	VEE9,VENN,VPM4,VPM8,VPM9,VS17,VS19,VSD1,VSD2
17	94305-20122	PIN, SPRING, 2X12	1	-	-	1	-----	VEE9,VENN,VPM4,VPM8,VPM9,VS17,VS19,VSD1,VSD2
18	99101-ZH8-0720	JET, MAIN, #72	(1)	-	-	(1)	-----	VEE9,VENN,VPM4,VPM8,VPM9,VS17,VS19,VSD1,VSD2
	99101-ZH8-0750	JET, MAIN, #75	(1)	-	-	(1)	-----	VEE9,VENN,VPM4,VPM8,VPM9,VS17,VS19,VSD1,VSD2
	99101-ZH8-0780	JET, MAIN, #78	1	-	-	1	-----	VEE9,VENN,VPM4,VPM8,VPM9,VS17,VS19,VSD1,VSD2
19	99204-ZE2-0400	JET SET, PILOT, #40	1	-	-	1	-----	VEE9,VENN,VPM4,VPM8,VPM9,VS17,VS19,VSD1,VSD2
20	16211-Z4V-000	INSULATOR, CARBURETOR	-	-	-	1	-----	VEE9,VENN,VPM4,VS19



E-15

AIR CLEANER(DUAL)

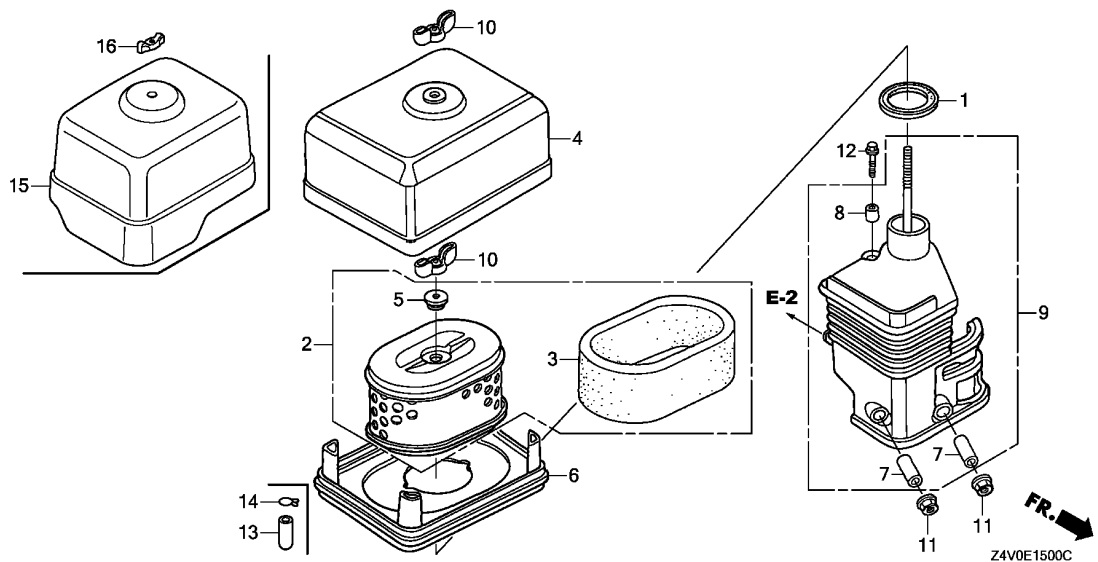

Ref. L.O.N. (Relative ref. Number) F.R.T.
No. Description

Ref. No.	Part No.	Description	Reqd. QTY				Serial No.	Parts catalogue code
			GX 200 UT	GX 200 RT	GX 200 UT2	GX 200 RT2		
1	16271-ZE1-000	PACKING, ELBOW	1	1	1	1	HX2, HXU, LX2, LX4, LXAU, PXU, QG2, QH26, QHQ4, QX2, QX26, QX4, QX7, QX9, QXAG, QXB2, QXD4, QXD9, QXE2, QXE4, QXE5, QXE6, QXU, RDG4, RH2, RHG4, RHQ4, RMG2, RX4, RXU, SAR, SHQ2, SHQ4, SM12, SM14, SM24, SMC2, SMC4, SMCR, SWG4, SX4, SX7, SX9, SXE4, SXE5, SXU, TX2, TX4, TXD1, TXDU, TXU, TXU1, VGG2, VGGN, VGS5, VGS9, VSD, VSD7, VSD9, VX2, VX4, VXU, VXU1	
2	17210-ZE1-822	ELEMENT, AIR CLEANER(DUAL) ..	1	1	1	1	HX2, HXU, LX2, LX4, LXAU, PXU, QG2, QH26, QHQ4, QX2, QX26, QX4, QX7, QX9, QXAG, QXB2, QXD4, QXD9, QXE2, QXE4, QXE5, QXE6, QXU, RDG4, RH2, RHG4, RHQ4, RMG2, RX4, RXU, SAR, SHQ2, SHQ4, SM12, SM14, SM24, SMC2, SMC4, SMCR, SWG4, SX4, SX7, SX9, SXE4, SXE5, SXU, TX2, TX4, TXD1, TXDU, TXU, TXU1, VGG2, VGGN, VGS5, VGS9, VSD, VSD7, VSD9, VX2, VX4, VXU, VXU1	
3	17218-ZE1-821	FILTER, OUTER	1	1	1	1	HX2, HXU, LX2, LX4, LXAU, PXU, QG2, QH26, QHQ4, QX2, QX26, QX4, QX7, QX9, QXAG, QXB2, QXD4, QXD9, QXE2, QXE4, QXE5, QXE6, QXU, RDG4, RH2, RHG4, RHQ4, RMG2, RX4, RXU, SAR, SHQ2, SHQ4, SM12, SM14, SM24, SMC2, SMC4, SMCR, SWG4, SX4, SX7, SX9, SXE4, SXE5, SXU, TX2, TX4, TXD1, TXDU, TXU, TXU1, VGG2, VGGN, VGS5, VGS9, VSD, VSD7, VSD9, VX2, VX4, VXU, VXU1	
4	17230-ZE1-820	COVER, AIR CLEANER(DUAL)	1	1	-	-	HX2, HXU, LX2, LX4, LXAU, PXU, QG2, QH26, QHQ4, QX2, QX26, QX4, QX7, QX9, QXB2, QXD4, QXD9, QXE2, QXE4, QXE5, QXE6, QXU, RH2, RHG4, RHQ4, RMG2, RX4, RXU, SAR, SHQ2, SHQ4, SM12, SMC2, SMC4, SMCR, SWG4, SX4, SX7, SX9, SXE4, SXE5, SXU, TX2, TX4, TXD1, TXDU, TXU, TXU1, VGG2, VGGN, VGS5, VGS9, VSD, VSD7, VSD9, VX2, VX4, VXU, VXU1	
5	17232-891-000	GROMMET, AIR CLEANER	1	1	1	1	HX2, HXU, LX2, LX4, LXAU, PXU, QG2, QH26, QHQ4, QX2, QX26, QX4, QX7, QX9, QXAG, QXB2, QXD4, QXD9, QXE2, QXE4, QXE5, QXE6, QXU, RDG4, RH2, RHG4, RHQ4, RMG2, RX4, RXU, SAR, SHQ2, SHQ4, SM12, SM14, SM24, SMC2, SMC4, SMCR, SWG4, SX4, SX7, SX9, SXE4, SXE5, SXU, TX2, TX4, TXD1, TXDU, TXU, TXU1, VGG2, VGGN, VGS5, VGS9, VSD, VSD7, VSD9, VX2, VX4, VXU, VXU1	
6	17235-ZE1-860	NOSE, SILENCER	1	1	-	-	RHG4, RMG2, SAR, SWG4, VGGN	

Ref. No.	Part No.	Description	Reqd. QTY				Serial No.	Parts catalogue code
			GX 200 UT	GX 200 RT	GX 200 UT2	GX 200 RT2		
(6)	17235-ZE1-831	NOSE, SILENCER	1	-	-	-	-----	HX2, HXU, LX2, LX4, LXAU, PXU, QG2, QH26, QHQ4, QX2, QX26, QX4, QX7, QX9, QXB2, QXD4, QXD9, QXE2, QXE4, QXE5, QXE6, QXU, RH2, RHQ4, RX4, RXU, SHQ2, SHQ4, SM12, SMC2, SMC4, SMC4, SMC4, SMC4, SX4, SX7, SX9, SXE4, SXE5, SXU, TX2, TX4, TXD1, TXDU, TXU, TXU1, VGG2, VGS5, VGS9, VSD, VSD7, VSD9, VX2, VX4, VXU, VXU1
	17235-Z4M-860	-	-	1	1	-----	RDG4, RHG4, RMG2, SAR, SWG4, VGGN
	17235-Z4M-830	-	-	1	-	-----	HX2, LX4, LXAU, PXU, QG2, QH26, QHQ4, QX2, QX4, QX9, QXAG, QXB2, QXD4, QXD9, QXE2, QXE4, QXE5, RH2, RHQ4, RX4, RXU, SHQ4, SM12, SM14, SM24, SMC4, SMC4, SMC4, SMC4, SX4, SX9, SXE5, SXU, TX2, TXD1, TXDU, VGS5, VSD9, VXU, VXU1
7	17238-ZE7-010	COLLAR, AIR CLEANER	2	2	2	2	-----	HX2, HXU, LX2, LX4, LXAU, PXU, QG2, QH26, QHQ4, QX2, QX26, QX4, QX7, QX9, QXAG, QXB2, QXD4, QXD9, QXE2, QXE4, QXE5, QXE6, QXU, RDG4, RH2, RHG4, RHQ4, RMG2, RX4, RXU, SAR, SHQ2, SHQ4, SM12, SM14, SM24, SMC2, SMC4, SMC4, SMC4, SX4, SX7, SX9, SXE4, SXE5, SXU, TX2, TX4, TXD1, TXDU, TXU, TXU1, VGG2, VGGN, VGS5, VGS9, VSD, VSD7, VSD9, VX2, VX4, VXU, VXU1
8	17239-ZE1-000	COLLAR B, AIR CLEANER	1	1	1	1	-----	HX2, HXU, LX2, LX4, LXAU, PXU, QG2, QH26, QHQ4, QX2, QX26, QX4, QX7, QX9, QXAG, QXB2, QXD4, QXD9, QXE2, QXE4, QXE5, QXE6, QXU, RDG4, RH2, RHG4, RHQ4, RMG2, RX4, RXU, SAR, SHQ2, SHQ4, SM12, SM14, SM24, SMC2, SMC4, SMC4, SMC4, SX4, SX7, SX9, SXE4, SXE5, SXU, TX2, TX4, TXD1, TXDU, TXU, TXU1, VGG2, VGGN, VGS5, VGS9, VSD, VSD7, VSD9, VX2, VX4, VXU, VXU1
9	17410-ZE1-020	ELBOW COMP., AIR CLEANER	1	1	-	-	-----	HX2, HXU, LX2, LX4, LXAU, PXU, QG2, QH26, QHQ4, QX2, QX26, QX4, QX7, QX9, QXB2, QXD4, QXD9, QXE2, QXE4, QXE5, QXE6, QXU, RH2, RHG4, RHQ4, RMG2, RX4, RXU, SAR, SHQ2, SHQ4, SM12, SMC2, SMC4, SMC4, SMC4, SMC4, SX4, SX7, SX9, SXE5, SXU, TX2, TX4, TXD1, TXDU, TXU, TXU1, VGG2, VGGN, VGS5, VGS9, VSD, VSD7, VSD9, VX2, VX4, VXU, VXU1
	17410-Z4M-000	-	-	1	1	-----	HX2, LX4, LXAU, PXU, QG2, QH26, QHQ4, QX2, QX4, QX9, QXAG, QXB2, QXD4, QXD9, QXE2, QXE4, QXE5, RDG4, RH2, RHG4, RHQ4, RMG2, RX4, RXU, SAR, SHQ4, SM12, SM14, SM24, SMC4, SMC4, SMC4, SMC4, SX4, SX9, SXE5, SXU, TX2, TXD1, TXDU, VGGN, VGS5, VSD9, VXU, VXU1
10	90325-044-000	NUT, TOOL BOX SETTING	2	2	1	1	-----	HX2, HXU, LX2, LX4, LXAU, PXU, QG2, QH26, QHQ4, QX2, QX26, QX4, QX7, QX9, QXAG, QXB2, QXD4, QXD9, QXE2, QXE4, QXE5, QXE6, QXU, RDG4, RH2, RHG4, RHQ4, RMG2, RX4, RXU, SAR, SHQ2, SHQ4, SM12, SM14, SM24, SMC2, SMC4, SMC4, SMC4, SX4, SX7, SX9, SXE4, SXE5, SXU, TX2, TX4, TXD1, TXDU, TXU, TXU1, VGG2, VGGN, VGS5, VGS9, VSD, VSD7, VSD9, VX2, VX4, VXU, VXU1
11	94050-06000	NUT, FLANGE, 6MM	2	2	2	2	-----	HX2, HXU, LX2, LX4, LXAU, PXU, QG2, QH26, QHQ4, QX2, QX26, QX4, QX7, QX9, QXAG, QXB2, QXD4, QXD9, QXE2, QXE4, QXE5, QXE6, QXU, RDG4, RH2, RHG4, RHQ4, RMG2, RX4, RXU, SAR, SHQ2, SHQ4, SM12, SM14, SM24, SMC2, SMC4, SMC4, SMC4, SX4, SX7, SX9, SXE4, SXE5, SXU, TX2, TX4, TXD1, TXDU, TXU, TXU1, VGG2, VGGN, VGS5, VGS9, VSD, VSD7, VSD9, VX2, VX4, VXU, VXU1
12	95701-06020-00	BOLT, FLANGE, 6X20	1	1	1	1	-----	HX2, HXU, LX2, LX4, LXAU, PXU, QG2, QH26, QHQ4, QX2, QX26, QX4, QX7, QX9, QXAG, QXB2, QXD4, QXD9, QXE2, QXE4, QXE5, QXE6, QXU, RDG4, RH2, RHG4, RHQ4, RMG2, RX4, RXU, SAR, SHQ2, SHQ4, SM12, SM14, SM24, SMC2, SMC4, SMC4, SMC4, SX4, SX7, SX9, SXE4, SXE5, SXU, TX2, TX4, TXD1, TXDU, TXU, TXU1, VGG2, VGGN, VGS5, VGS9, VSD, VSD7, VSD9, VX2, VX4, VXU, VXU1
13	90634-ZL8-H00	CAP, SEALING	1	-	-	1	-----	VGGN
14	95002-02100	CLIP, TUBE(B10)	1	-	-	1	-----	VGGN
15	17231-Z4M-000	COVER, AIR CLEANER	-	-	1	1	-----	HX2, LX4, LXAU, PXU, QG2, QH26, QHQ4, QX2, QX4, QX9, QXB2, QXD4, QXD9, QXE2, QXE4, QXE5, RH2, RHG4, RHQ4, RMG2, RX4, RXU, SAR, SHQ4, SM12, SM14, SM24, SMC4, SMC4, SMC4, SMC4, SX4, SX9, SXE5, SXU, TX2, TXD1, TXDU, VGGN, VGS5, VSD9, VXU, VXU1
	17231-Z4M-010	-	-	1	1	-----	QXAG, RDG4
16	90300-Z1V-000	NUT, AIR CLEANER	-	-	1	1	-----	HX2, LX4, LXAU, PXU, QG2, QH26, QHQ4, QX2, QX4, QX9, QXAG, QXB2, QXD4, QXD9, QXE2, QXE4, QXE5, RDG4, RH2, RHG4, RHQ4, RMG2, RX4, RXU, SAR, SHQ4, SM12, SM14, SM24, SMC4, SMC4, SMC4, SMC4, SX4, SX9, SXE5, SXU, TX2, TXD1, TXDU, VGGN, VGS5, VSD9, VXU, VXU1



E-15-1

AIR CLEANER(STANDARD)

F 1

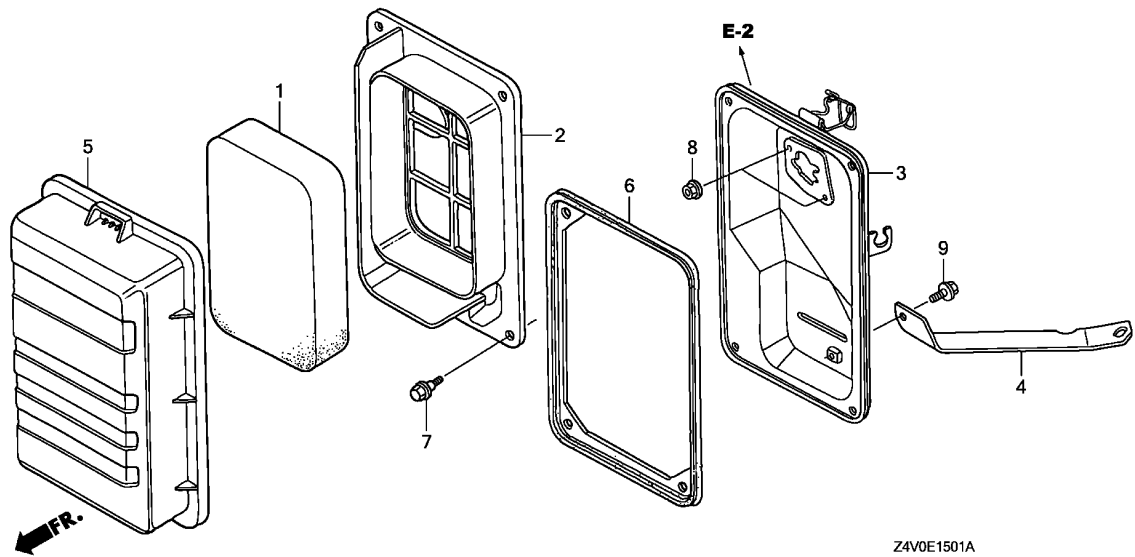

Ref. No.	L.O.N.	(Relative ref. Number) Description	F.R.T.
----------	--------	------------------------------------	--------

2

Ref. No.	Part No.	Description	Reqd. QTY				Serial No.	Parts catalogue code
			GX 200 UT	GX 200 RT	GX 200 UT2	GX 200 RT2		
1	17211-ZB2-000	ELEMENT, AIR CLEANER	1	-	-	1	-----	VEE9,VPM4,VPM8,VPM9,VS17,VS19,VSD1,VSD2
2	17212-ZB2-000	SEPARATOR, AIR CLEANER	1	-	-	1	-----	VEE9,VPM4,VPM8,VPM9,VS17,VS19,VSD1,VSD2
3	17220-ZB2-000	CASE COMP., AIR CLEANER	1	-	-	1	-----	VEE9,VPM4,VPM8,VPM9,VS17,VS19,VSD1,VSD2
4	17222-ZL0-V30	STAY, AIR CLEANER	1	-	-	1	-----	VEE9,VPM4,VPM8,VPM9,VS17,VS19,VSD1,VSD2
5	17231-ZB2-000	COVER, AIR CLEANER	1	-	-	1	-----	VEE9,VPM4,VPM8,VPM9,VS17,VS19,VSD1,VSD2
6	17252-ZB2-000	SEAL, AIR CLEANER	1	-	-	1	-----	VEE9,VPM4,VPM8,VPM9,VS17,VS19,VSD1,VSD2
7	90115-459-770	BOLT, WINKER SETTING	4	-	-	-	-----	VEE9,VPM4,VPM8,VPM9,VS17,VS19,VSD1,VSD2
	90115-29J-000	-	-	-	4	-----	VEE9,VPM4,VS19
8	94050-06080	NUT, FLANGE, 6MM	2	-	-	2	-----	VEE9,VPM4,VPM8,VPM9,VS17,VS19,VSD1,VSD2
9	95701-06010-00	BOLT, FLANGE, 6X10	1	-	-	1	-----	VEE9,VPM4,VPM8,VPM9,VS17,VS19,VSD1,VSD2

E-15-2

AIR CLEANER(OIL BATH)

F 2

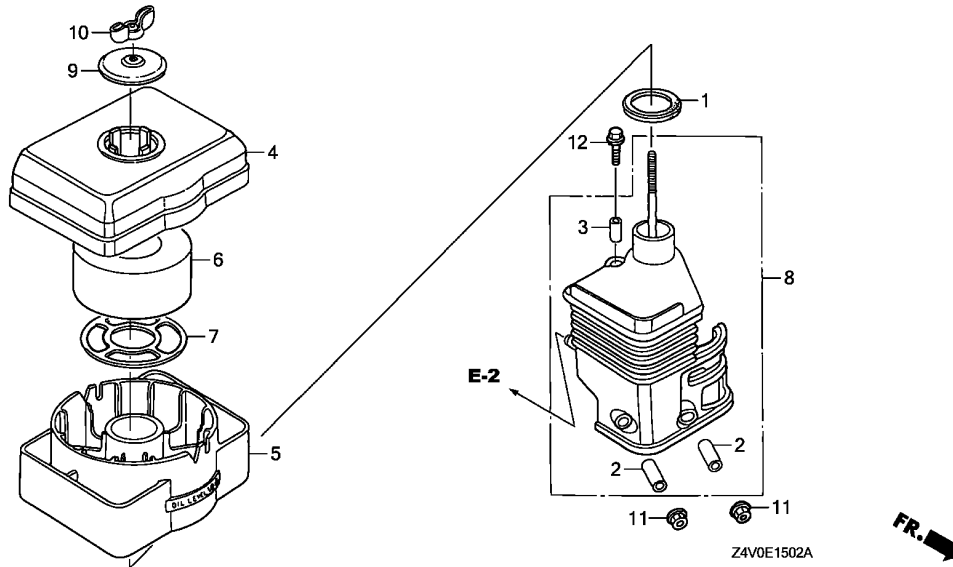

Ref. No.	L.O.N.	(Relative ref. Number) Description	F.R.T.
----------	--------	------------------------------------	--------

Ref. No.	Part No.	Description	Reqd. QTY				Serial No.	Parts catalogue code
			GX 200 UT	GX 200 RT	GX 200 UT2	GX 200 RT2		
1	16271-ZE1-000	PACKING, ELBOW	1	-	1	-	-----	QMP4
2	17238-ZE7-010	COLLAR, AIR CLEANER	2	-	2	-	-----	QMP4
3	17239-ZE1-000	COLLAR B, AIR CLEANER	1	-	1	-	-----	QMP4
4	17401-ZE1-810	BODY, CLEANER(OIL BATH)	1	-	1	-	-----	QMP4
5	17402-ZE1-810	PAN, CLEANER OIL(OIL BATH) ..	1	-	1	-	-----	QMP4
6	17403-ZE1-810	ELEMENT, AIR CLEANER(OIL BATH)	1	-	1	-	-----	QMP4
7	17404-841-000	GRID, AIR CLEANER	1	-	1	-	-----	QMP4
8	17410-ZE1-020	ELBOW COMP., AIR CLEANER	1	-	1	-	-----	QMP4
9	17421-ZE1-000	CAP, CLEANER	1	-	1	-	-----	QMP4
10	90325-044-000	NUT, TOOL BOX SETTING	1	-	1	-	-----	QMP4
11	94050-06000	NUT, FLANGE, 6MM	2	-	2	-	-----	QMP4
12	95701-06020-00	BOLT, FLANGE, 6X20	1	-	1	-	-----	QMP4

2

E-15-3

AIR CLEANER(CYCLONE)

F 3

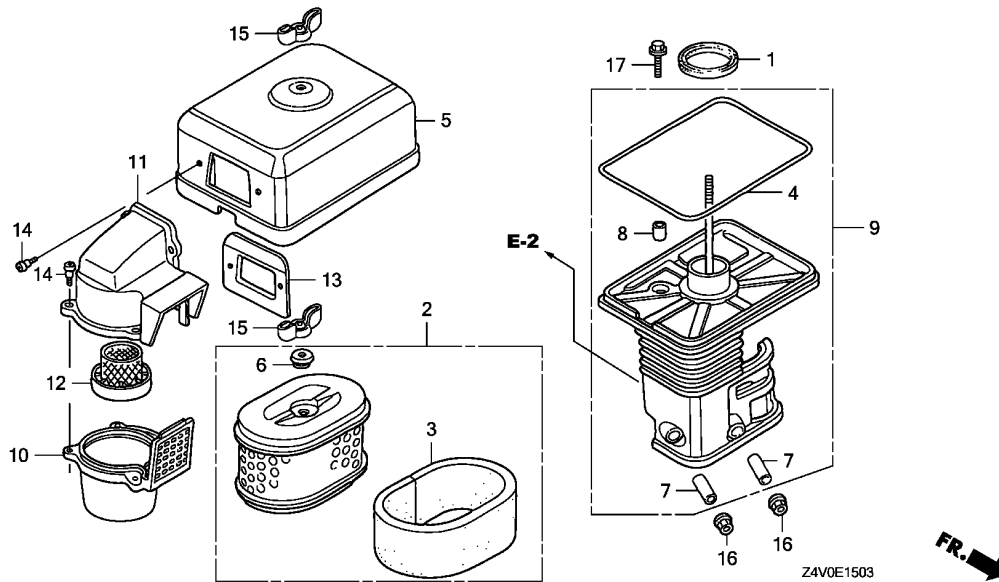

Ref. L.O.N. (Relative ref. Number) F.R.T.
No. Description

Ref. No.	Part No.	Description	Reqd. QTY				Serial No.	Parts catalogue code
			GX 200 UT	GX 200 RT	GX 200 UT2	GX 200 RT2		
1	16271-ZE1-000	PACKING, ELBOW	1	-	1	-	QH4,QXC9,SXW9	
2	17210-ZE1-822	ELEMENT, AIR CLEANER(DUAL) ..	1	-	1	-	QH4,QXC9,SXW9	
3	17218-ZE1-821	FILTER, OUTER	1	-	1	-	QH4,QXC9,SXW9	
4	17219-733-010	PACKING, AIR CLEANER COVER ..	1	-	1	-	QH4,QXC9,SXW9	
5	17230-ZE1-841	COVER, AIR CLEANER(DUAL)	1	-	1	-	QH4,QXC9,SXW9	
6	17232-891-000	GROMMET, AIR CLEANER	1	-	1	-	QH4,QXC9,SXW9	
7	17238-ZE7-010	COLLAR, AIR CLEANER	2	-	2	-	QH4,QXC9,SXW9	
8	17239-733-000	COLLAR B, AIR CLEANER	1	-	1	-	QH4,QXC9,SXW9	
9	17410-ZE1-840	ELBOW COMP., AIR CLEANER	1	-	1	-	QH4,QXC9,SXW9	
10	17470-ZE1-842	CASE, PRE AIR CLEANER	1	-	1	-	QH4,QXC9,SXW9	
11	17475-ZE1-841	CAP, PRE AIR CLEANER	1	-	1	-	QH4,QXC9,SXW9	
12	17476-ZE1-841	GUIDE, PRE AIR CLEANER	1	-	1	-	QH4,QXC9,SXW9	
13	17478-ZE1-841	PLATE, PRE AIR CLEANER	1	-	1	-	QH4,QXC9,SXW9	
14	90300-GB0-900	BOLT, MUDGUARD	5	-	5	-	QH4,QXC9,SXW9	
15	90325-044-000	NUT, TOOL BOX SETTING	2	-	2	-	QH4,QXC9,SXW9	
16	94050-06000	NUT, FLANGE, 6MM	2	-	2	-	QH4,QXC9,SXW9	
17	95701-06020-00	BOLT, FLANGE, 6X20	1	-	1	-	QH4,QXC9,SXW9	

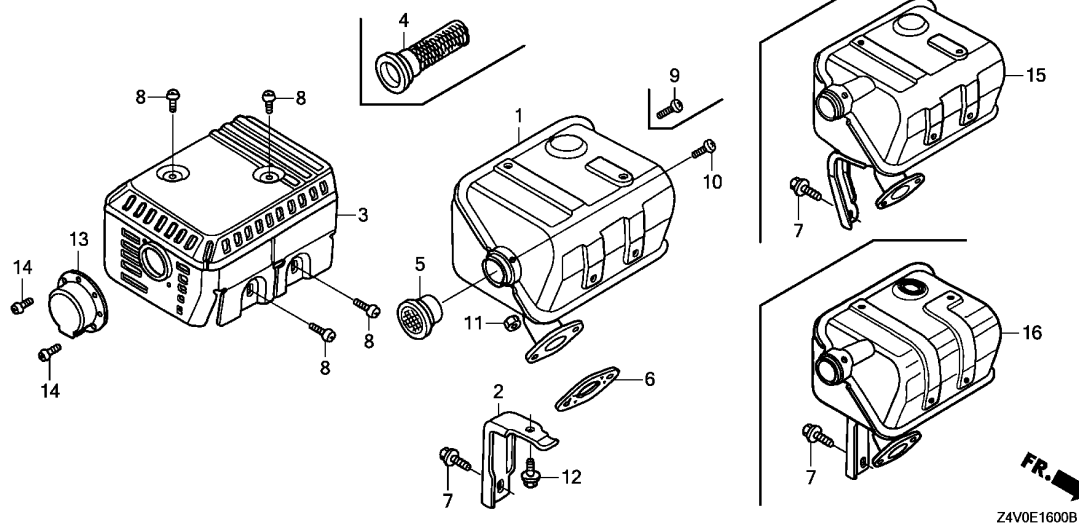

Ref. L.O.N. (Relative ref. Number) F.R.T.
No. Description

Ref. No.	Part No.	Description	Reqd. QTY				Serial No.	Parts catalogue code
			GX 200 UT	GX 200 RT	GX 200 UT2	GX 200 RT2		
1	18310-ZL0-000	MUFFLER COMP.	1	1	-	-	HX2, HXU, LX2, LX4, LXAU, PXU, QH26, QHQ4, QMP4, QX2, QX26, QX4, QXB2, QXC9, QXD4, QXE2, QXE4, QXE5, QXE6, QXU, RH2, RHQ4, RX4, RXU, SAR, SHQ2, SHQ4, SM12, SMC2, SMC4, SMCR, SX4, SXE4, SXE5, SXU, TX2, TX4, TXU, TXU1, VSD, VX2, VX4, VXU, VXU1	
	18310-ZL0-800	MUFFLER COMP. (ARRESTER)	1	1	-	-	QG2, QH4, RMG2, TXD1, TXDU, VGG2, VGGN	
	18310-ZL0-000	MUFFLER COMP.	(1)	(1)	-	-	QH4, QX9, QXD9, RHG4, RMG2, SWG4, SX9, TXD1, TXDU, VEE9, VGGN, VGS9, VPM4, VPM8, VPM9, VS19, VSD2, VSD9	
	18310-Z8K-870	MUFFLER COMP. (SILENT)	1	-	-	-	QX7, QX9, QXD9, SX7, SX9, VGS5, VGS9, VSD7, VSD9	
2	18315-ZE1-000	STAY, MUFFLER	1	1	-	-	HX2, HXU, LX2, LX4, LXAU, PXU, QG2, QH26, QH4, QHQ4, QMP4, QX2, QX26, QX4, QX7, QX9, QXB2, QXC9, QXD4, QXD9, QXE2, QXE4, QXE5, QXE6, QXU, RH2, RHQ4, RMG2, RX4, RXU, SAR, SHQ2, SHQ4, SM12, SMC2, SMC4, SMCR, SX4, SX7, SX9, SXE4, SXE5, SXU, TX2, TX4, TXD1, TXDU, TXU, TXU1, VGG2, VGGN, VGS5, VGS9, VSD, VSD7, VSD9, VX2, VX4, VXU, VXU1	
3	18320-ZF1-H51	PROTECTOR, MUFFLER(SILENT) ..	1	1	-	-	HX2, HXU, LX2, LX4, LXAU, PXU, QG2, QH26, QH4, QHQ4, QMP4, QX2, QX26, QX4, QX7, QX9, QXB2, QXC9, QXE2, QXE4, QXE5, QXE6, QXU, RH2, RHQ4, RMG2, RX4, RXU, SAR, SHQ4, SM12, SMC4, SX4, SX7, SX9, SXE4, SXE5, SXU, TX2, TX4, TXD1, TXDU, TXU, TXU1, VGG2, VGGN, VGS5, VGS9, VSD, VSD7, VSD9, VX2, VX4, VXU, VXU1	
	18320-ZF1-H52	1	-	-	-	QXD4, QXD9, SHQ2, SMC2, SMCR	
	18320-ZF1-H01	PROTECTOR, MUFFLER(STD.) (BLACK)	-	1	-	-	RHG4	
	18320-Z4V-000	PROTECTOR COMP., MUFFLER	-	-	1	1	HX2, LX4, LXAU, PXU, QG2, QH26, QHQ4, QMP4, QX2, QX4, QX9, QXAG, QXB2, QXC9, QXD4, QXD9, QXE2, QXE4, QXE5, RH2, RHQ4, RMG2, RX4, RXU, SAR, SHQ4, SM12, SM14, SM24, SMC4, SMCR, SX4, SX9, SXE5, SXU, SXW9, TX2, TXD1, TXDU, VGGN, VGS5, VSD9, VXU, VXU1	
	18320-Z4M-000	PROTECTOR COMP., MUFFLER(STD.)	-	-	-	1	RDG4, RHG4	



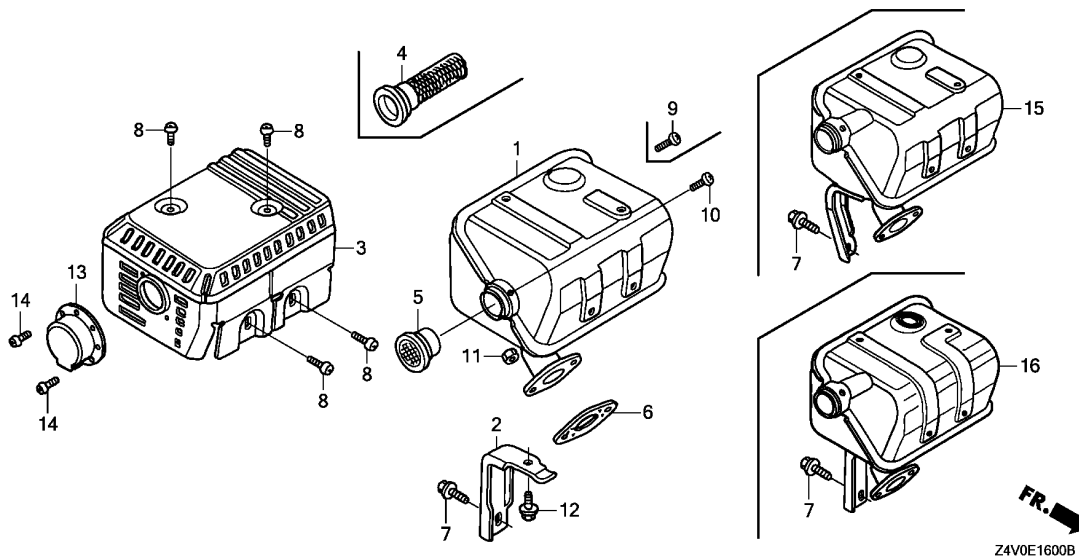

Ref. No.	Part No.	Description	Reqd. QTY				Serial No.	Parts catalogue code
			GX 200 UT	GX 200 RT	GX 200 UT2	GX 200 RT2		
4	18355-ZL0-000	ARRESTER, SPARK	(1)	(1)	(1)	(1)	-----	HX2, HXU, LX2, LX4, LXAU, PXU, QH26, QHQ4, QMP4, QX2, QX26, QX4, QX7, QX9, QXAG, QXB2, QXC9, QXD4, QXD9, QXE2, QXE4, QXE5, QXE6, QXU, RDG4, RH2, RHG4, RHQ4, RX4, RXU, SAR, SHQ2, SHQ4, SM12, SM14, SM24, SMC2, SMC4, SMCR, SWG4, SX4, SX7, SX9, SXE4, SXE5, SXU, TX2, TX4, TXU, TXU1, VEE9, VENN, VGS5, VGS9, VPM4, VPM8, VPM9, VS19, VSD, VSD2, VSD7, VSD9, VX2, VX4, VXU, VXU1
5	18361-ZL0-000	NETTING, WIRE FLANGE	1	1	1	1	-----	QG2, QH4, RMG2, SXW9, TXD1, TXDU, VGG2, VGGN
6	18381-Z0T-801	GASKET, MUFFLER	1	1	-	1	-----	HX2, HXU, LXAU, QH4, QMP4, QXC9, QXD4, QXD9, QXE2, QXE4, QXE5, QXE6, RDG4, RH2, RHG4, RHQ4, RMG2, RX4, RXU, SAR, SHQ2, SMC2, SMCR, SXE4, SXE5, TXD1, TXDU, VENN, VGGN
	18381-ZH8-800	(1)	-	-	-	-----	VEE9
	18381-Z0T-801	1	-	-	-	1132191	LX2, LX4, PXU, QG2, QH26, QHQ4, QX2, QX26, QX4, QX7, QX9, QXB2, QXU, SHQ4, SM12, SMC4, SX4, SX7, SX9, SXU, TX2, TX4, TXU, TXU1, VGG2, VGS5, VGS9, VSD, VSD7, VSD9, VX2, VX4, VXU, VXU1
	18381-Z0T-801	1	-	-	-	1132192	LX2, LX4, PXU, QG2, QH26, QHQ4, QX2, QX26, QX4, QX7, QX9, QXB2, QXU, SHQ4, SM12, SMC4, SX4, SX7, SX9, SXU, TX2, TX4, TXU, TXU1, VGG2, VGS5, VGS9, VSD, VSD7, VSD9, VX2, VX4, VXU, VXU1
7	90016-ZE1-000	BOLT, FLANGE, 6X13(CT200) ...	1	1	1	1	-----	SWG4, VEE9, VENN, VPM4, VS19
			-	-	-	(1)	-----	HX2, HXU, LX2, LX4, LXAU, PXU, QG2, QH26, QH4, QHQ4, QMP4, QX2, QX26, QX4, QX7, QX9, QXAG, QXB2, QXC9, QXD4, QXD9, QXE2, QXE4, QXE5, QXE6, QXU, RDG4, RH2, RHG4, RHQ4, RMG2, RX4, RXU, SAR, SHQ2, SHQ4, SM12, SM14, SM24, SMC2, SMC4, SMCR, SX4, SX7, SX9, SXE4, SXE5, SXU, SXW9, TX2, TX4, TXD1, TXDU, TXU, TXU1, VGG2, VGGN, VGS5, VGS9, VSD, VSD7, VSD9, VX2, VX4, VXU, VXU1

Ref. No.	Part No.	Description	Reqd. QTY				Serial No.	Parts catalogue code
			GX 200 UT	GX 200 RT	GX 200 UT2	GX 200 RT2		
8	90050-ZE1-000	SCREW, TAPPING, 5X8	4	4	4	4	HX2, HXU, LX2, LX4, LXAU, PXU, QG2, QH26, QH4, QHQ4, QMP4, QX2, QX26, QX4, QX7, QX9, QXAG, QXB2, QXC9, QXD4, QXD9, QXE2, QXE4, QXE5, QXE6, QXU, RDG4, RH2, RHG4, RHQ4, RMG2, RX4, RXU, SAR, SHQ2, SHQ4, SM12, SM14, SM24, SMC2, SMC4, SMCR, SX4, SX7, SX9, SXE4, SXE5, SXU, SXW9, TX2, TX4, TXD1, TXDU, TXU, TXU1, VGG2, VGGN, VGS5, VGS9, VSD, VSD7, VSD9, VX2, VX4, VXU, VXU1	
9	90055-ZE1-000	SCREW, TAPPING, 4X6	(1)	(1)	-	(1)	HX2, HXU, LX2, LX4, LXAU, PXU, QH26, QH4, QHQ4, QMP4, QX2, QX26, QX4, QX7, QX9, QXB2, QXD4, QXD9, QXE2, QXE4, QXE5, QXE6, QXU, RDG4, RH2, RHG4, RHQ4, RMG2, RX4, RXU, SHQ2, SHQ4, SM12, SMC2, SMC4, SMCR, SWG4, SX4, SX7, SX9, SXE4, SXE5, SXU, TX2, TX4, TXD1, TXDU, TXU, TXU1, VEE9, VENN, VGGN, VGS5, VGS9, VPM4, VPM8, VPM9, VS19, VSD, VSD2, VSD7, VSD9, VX2, VX4, VXU, VXU1	
10	90056-ZL0-000	SCREW, TAPPING, 4X6	1	1	-	1	HX2, HXU, LX2, LX4, LXAU, PXU, QG2, QH26, QH4, QHQ4, QMP4, QX2, QX26, QX4, QX7, QX9, QXB2, QXC9, QXD4, QXD9, QXE2, QXE4, QXE5, QXE6, QXU, RH2, RHQ4, RMG2, RX4, RXU, SAR, SHQ2, SHQ4, SM12, SMC2, SMC4, SMCR, SX4, SX7, SX9, SXE4, SXE5, SXU, TX2, TX4, TXD1, TXDU, TXU, TXU1, VGG2, VGGN, VGS5, VGS9, VSD, VSD7, VSD9, VX2, VX4, VXU, VXU1	
			-	-	1	-	QG2, QX9, QXD9, SX9, SXW9, TXD1, TXDU, VGS5, VSD9	
11	94001-08000-0S	NUT, HEX., 8MM	2	2	2	2	HX2, HXU, LX2, LX4, LXAU, PXU, QG2, QH26, QH4, QHQ4, QMP4, QX2, QX26, QX4, QX7, QX9, QXAG, QXB2, QXC9, QXD4, QXD9, QXE2, QXE4, QXE5, QXE6, QXU, RDG4, RH2, RHG4, RHQ4, RMG2, RX4, RXU, SAR, SHQ2, SHQ4, SM12, SM14, SM24, SMC2, SMC4, SMCR, SX4, SX7, SX9, SXE4, SXE5, SXU, SXW9, TX2, TX4, TXD1, TXDU, TXU, TXU1, VGG2, VGGN, VGS5, VGS9, VSD, VSD7, VSD9, VX2, VX4, VXU, VXU1	
12	95701-06012-00	BOLT, FLANGE, 6X12	1	1	-	-	HX2, HXU, LX2, LX4, LXAU, PXU, QG2, QH26, QH4, QHQ4, QMP4, QX2, QX26, QX4, QX7, QX9, QXB2, QXC9, QXD4, QXD9, QXE2, QXE4, QXE5, QXE6, QXU, RH2, RHQ4, RMG2, RX4, RXU, SAR, SHQ2, SHQ4, SM12, SMC2, SMC4, SMCR, SX4, SX7, SX9, SXE4, SXE5, SXU, TX2, TX4, TXD1, TXDU, TXU, TXU1, VGG2, VGGN, VGS5, VGS9, VSD, VSD7, VSD9, VX2, VX4, VXU, VXU1	
13	18331-883-810	CAP, MUFFLER	1	-	-	-	QXC9	
14	90055-ZE1-000	SCREW, TAPPING, 4X6	2	-	-	-	QXC9	
15	18310-ZH7-V90	MUFFLER COMP.	-	1	-	-	RHG4	
16	18310-Z4V-800	MUFFLER COMP. (ARRESTER)	-	-	1	1	QG2, RMG2, SXW9, TXD1, TXDU, VGGN	
	18310-Z4V-000	MUFFLER COMP.	-	-	1	-	HX2, LX4, LXAU, PXU, QH26, QHQ4, QMP4, QX2, QX4, QX9, QXAG, QXB2, QXC9, QXD4, QXD9, QXE2, QXE4, QXE5, RH2, RHQ4, RX4, RXU, SAR, SHQ4, SM12, SM14, SM24, SMC4, SMCR, SX4, SX9, SXE5, SXU, TX2, VGS5, VSD9, VXU, VXU1	
	18310-Z4M-V90	-	-	-	1	RDG4, RHG4	
	18310-Z4V-000	-	-	-	(1)	SWG4, VEE9, VENN, VPM4, VS19	

E-16-1

EXHAUST PIPE

F 7

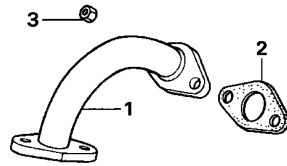

FR.

Z4V0-E1601

Ref. L.O.N. (Relative ref. Number) F.R.T.
No. Description

Ref. No.	Part No.	Description	Reqd. QTY				Serial No.	Parts catalogue code
			GX 200 UT	GX 200 RT	GX 200 UT2	GX 200 RT2		
1	18330-ZB2-000	PIPE COMP., EX.	1	-	-	1	----- VS17,VS19,VSD1	
2	18381-ZH8-800	GASKET, MUFFLER	1	-	-	-	----- 1132191 VS17,VS19,VSD1	
	18381-ZOT-801	1	-	-	-	----- 1132192 VS17,VS19,VSD1	
			-	-	-	1	----- VS19	
3	94001-08000-0S	NUT, HEX., 8MM	2	-	-	2	----- VS17,VS19,VSD1	

2

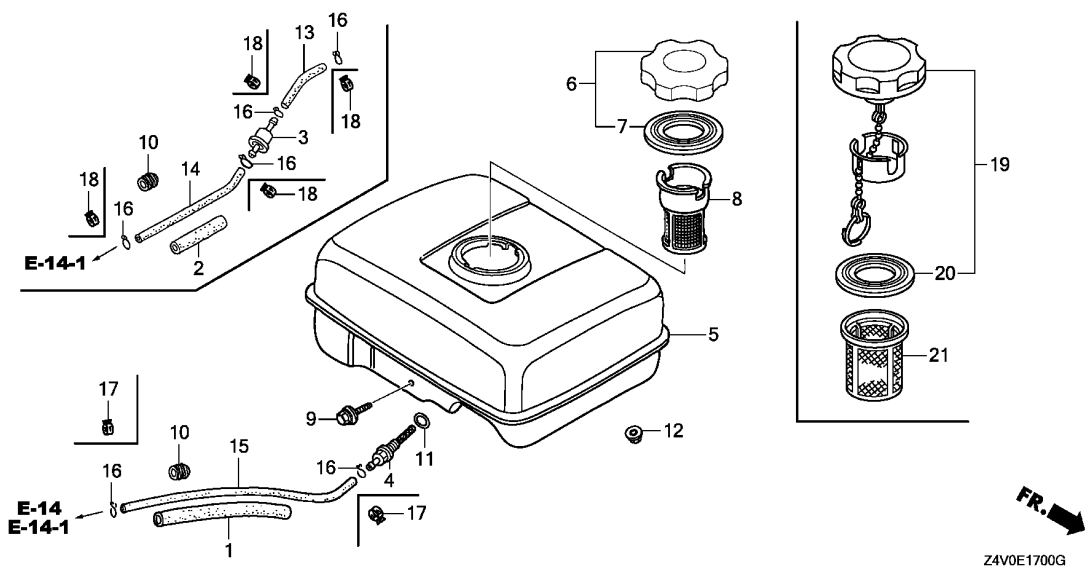

Ref. No.	L.O.N.	(Relative ref. Number) Description	F.R.T.

FR. →
Z4V0E1700G

Ref. No.	Part No.	Description	Reqd. QTY				Serial No.	Parts catalogue code
			GX 200 UT	GX 200 RT	GX 200 UT2	GX 200 RT2		
1	16854-ZH8-000	RUBBER, SUPPORTER(107MM)	1	1	-	1	HX2, HXU, LX2, LX4, LXAU, PXU, QG2, QH26, QH4, QHQ4, QMP4, QX2, QX26, QX4, QX7, QX9, QXB2, QXC9, QXD4, QXD9, QXE2, QXE4, QXE5, QXE6, QXU, RH2, RHQ4, RX4, RXU, SAR, SHQ2, SHQ4, SM12, SMC2, SMC4, SMCR, SWG4, SX4, SX7, SX9, SXE4, SXE5, SXU, TX2, TX4, TXD1, TXDU, TXU, TXU1, VEE9, VGG2, VGGN, VGS5, VGS9, VS17, VS19, VSD, VSD1, VSD2, VSD7, VSD9, VX2, VX4, VXU, VXU1	
2	16854-ZH8-810	RUBBER, SUPPORTER(50MM)	1	-	-	1	VPM4, VPM8, VPM9	
3	16910-GB2-005	STRAINER COMP., FUEL	1	-	-	1	VPM4, VPM8, VPM9	
4	16955-ZE1-000	JOINT, FUEL TANK	1	1	-	-	HX2, HXU, LX2, LX4, LXAU, PXU, QG2, QH26, QH4, QHQ4, QMP4, QX2, QX26, QX4, QX7, QX9, QXB2, QXC9, QXE2, QXE4, QXE5, QXE6, QXU, RH2, RHQ4, RX4, RXU, SAR, SHQ2, SHQ4, SM12, SMC2, SMC4, SX4, SX7, SX9, SXE4, SXE5, SXU, TX2, TX4, TXD1, TXDU, TXU, TXU1, VGS5, VGS9, VSD, VSD7, VSD9, VX2, VX4, VXU, VXU1	
	16955-ZE1-010	1	-	-	-	SMCR	
	16955-ZE1-000	1	-	-	1577022	QXD4	
	16955-ZE1-010	1	-	-	1577058	QXD9	
	16955-ZE1-010	1	-	-	1577023	QXD4	
	16955-ZE1-010	1	-	-	1577059	QXD9	
5	17510-Z0T-010ZC	TANK COMP., FUEL *NH31*.....MCKINLEY WHITE	1	1	-	-	HX2, HXU, QH4, QXC9, QXD4, QXD9, QXE2, QXE4, QXE5, QXE6, RH2, RHQ4, RX4, RXU, SAR, SHQ2, SMC2, SXE4, SXE5, TXD1, TXDU	
	17510-Z0T-010ZA	*NH1*.....BLACK	1	-	-	-	HX2, HXU, QXC9, QXE2, QXE4, QXE6, RH2, RHQ4, RX4, RXU, SMCR	
	17510-Z0T-000ZC	*NH31*.....MCKINLEY WHITE	1	-	-	1443526	LX2, LX4, LXAU, PXU, QG2, QH26, QHQ4, QMP4, QX2, QX26, QX4, QX7, QX9, QXB2, QXU, SHQ4, SM12, SMC4, SX4, SX7, SX9, SXU, TX2, TX4, TXU, TXU1, VGS5, VGS9, VSD, VSD7, VSD9, VX2, VX4, VXU, VXU1	
	17510-Z0T-000ZA	*NH1*.....BLACK	1	-	-	1443526	LX2, LX4, PXU, QG2, QH26, QHQ4, QX2, QX26, QX4, QX7, QX9, QXB2, QXU, SHQ4, SM12, SMC4, SX4, SX7, SX9, TX2, TXU, TXU1, VSD, VSD7, VSD9, VX2, VX4, VXU, VXU1	
	17510-Z0T-010ZC	*NH31*.....MCKINLEY WHITE	1	-	-	1443527	LX2, LX4, LXAU, PXU, QG2, QH26, QHQ4, QMP4, QX2, QX26, QX4, QX7, QX9, QXB2, QXU, SHQ4, SM12, SMC4, SX4, SX7, SX9, SXU, TX2, TX4, TXU, TXU1, VGS5, VGS9, VSD, VSD7, VSD9, VX2, VX4, VXU, VXU1	



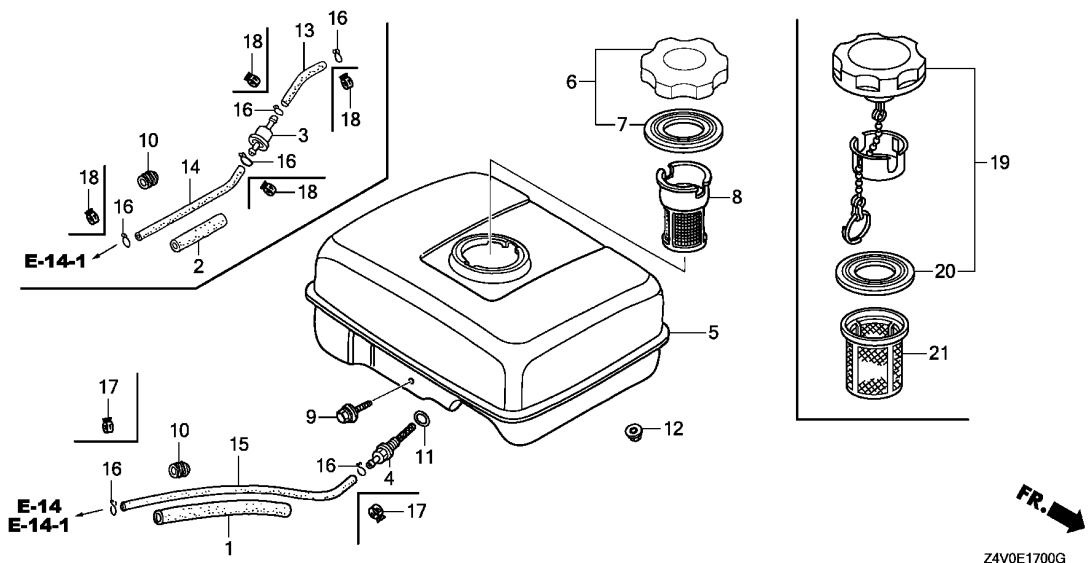

Ref. No.	Part No.	Description	Reqd. QTY				Serial No.	Parts catalogue code
			GX 200 UT	GX 200 RT	GX 200 UT2	GX 200 RT2		
(5)	17510-Z0T-010ZA	TANK COMP., FUEL *NH1*.....BLACK	1	-	-	-	1443527 -----	LX2,LX4,PXU,QG2,QH26,QHQ4,QX2,QX26,QX4,QX7,QX9,QXB2,QXU,SHQ4,SM12,SMC4,SX4,SX7,SX9,TX2,TXU,TXU1,VSD,VSD7,VSD9,VX2,VX4,VXU,VXU1
6	17620-Z0T-813	CAP COMP., FUEL FILLER (CHROME PLATED) (RADICON)	1	-	-	-	1259678 -----	LX2,LX4,LXAU,PXU,QG2,QH26,QHQ4,QX2,QX26,QX4,QX7,QX9,QXB2,QXU,SHQ4,SM12,SMC4,SX4,SX7,SX9,SXU,TX2,TX4,TXU,TXU1,VGS5,VGS9,VSD,VSD7,VSD9,VX2,VX4,VXU,VXU1
7	17631-Z0T-801	PACKING, FUEL FILLER CAP (39X62X3) (RADICON)	1	-	-	-	1259678 -----	LX2,LX4,LXAU,PXU,QG2,QH26,QHQ4,QX2,QX26,QX4,QX7,QX9,QXB2,QXU,SHQ4,SM12,SMC4,SX4,SX7,SX9,SXU,TX2,TX4,TXU,TXU1,VGS5,VGS9,VSD,VSD7,VSD9,VX2,VX4,VXU,VXU1
8	17672-ZE2-W01	FILTER, FUEL	1	-	-	-	1259678 -----	SM12
9	90004-ZL0-003	BOLT, FLANGE, 6X34	1	1	-	-	-----	HX2,HXU,LX2,LX4,LXAU,PXU,QG2,QH26,QH4,QHQ4,QMP4,QX2,QX26,QX4,QX7,QX9,QXB2,QXC9,QXD4,QXD9,QXE2,QXE4,QXE5,QXE6,QXU,RH2,RHQ4,RX4,RXU,SAR,SHQ2,SHQ4,SM12,SMC2,SMC4,SMCR,SX4,SX7,SX9,SXE4,SXE5,SXU,TX2,TX4,TXD1,TXDU,TXU,TXU1,VGS5,VGS9,VSD,VSD7,VSD9,VX2,VX4,VXU,VXU1
10	90854-ZB3-000	RUBBER, FUEL(9X15X20)	1	-	-	1	-----	VENN,VPM4,VPM8,VPM9
11	91353-671-004	O-RING, 14MM(NOK)	1	1	-	-	-----	HX2,HXU,LX2,LX4,LXAU,PXU,QG2,QH26,QH4,QHQ4,QMP4,QX2,QX26,QX4,QX7,QX9,QXB2,QXC9,QXD4,QXD9,QXE2,QXE4,QXE5,QXE6,QXU,RH2,RHQ4,RX4,RXU,SAR,SHQ2,SHQ4,SM12,SMC2,SMC4,SMCR,SX4,SX7,SX9,SXE4,SXE5,SXU,TX2,TX4,TXD1,TXDU,TXU,TXU1,VGS5,VGS9,VSD,VSD7,VSD9,VX2,VX4,VXU,VXU1

Ref. No.	Part No.	Description	Reqd. QTY				Serial No.	Parts catalogue code
			GX 200 UT	GX 200 RT	GX 200 UT2	GX 200 RT2		
12	94050-06000	NUT, FLANGE, 6MM	2	2	-	-	HX2, HXU, LX2, LX4, LXAU, PXU, QG2, QH26, QH4, QHQ4, QMP4, QX2, QX26, QX4, QX7, QX9, QXB2, QXC9, QXD4, QXD9, QXE2, QXE4, QXE5, QXE6, QXU, RH2, RHQ4, RX4, RXU, SAR, SHQ2, SHQ4, SM12, SMC2, SMC4, SMCR, SX4, SX7, SX9, SXE4, SXE5, SXU, TX2, TX4, TXD1, TXDU, TXU, TXU1, VGS5, VGS9, VSD, VSD7, VSD9, VX2, VX4, VXU, VXU1	
13	95001-45035-40	TUBE, FUEL, 4.5X35 (95001-45001-60M)	1	-	-	-	1104342 VPM4, VPM8, VPM9	
	91424-24G-831	TUBE, FUEL, 4.5X35(FKM)	1	-	-	-	1104343 VPM4, VPM8, VPM9	
14	95001-45110-40	TUBE, FUEL, 4.5X110 (95001-45001-60M)	1	-	-	-	1104342 VPM4, VPM8, VPM9	
	91424-24G-811	TUBE, FUEL, 4.5X110(FKM)	1	-	-	-	1104343 VPM4, VPM8, VPM9	
	91424-24G-812	-	-	-	1	VPM4	
15	91424-24F-802	TUBE, FUEL, 4.5X140(FKM)	1	1	-	-	HX2, HXU, QH4, QXC9, QXD4, QXD9, QXE2, QXE4, QXE5, QXE6, RH2, RHQ4, RX4, RXU, SAR, SHQ2, SMC2, SMCR, SXE4, SXE5, LXAU, QMP4, TXD1, TXDU, VGGN, VEE9	
	91424-24F-801	1	-	-	-	1080499 LX2, LX4, PXU, QG2, QH26, QHQ4, QX2, QX26, QX4, QX7, QX9, QXB2, QXU, SHQ4, SM12, SMC4, SX4, SX7, SX9, SXU, TX2, TX4, TXU, TXU1, VGG2, VGS5, VGS9, VSD, VSD7, VSD9, VX2, VX4, VXU, VXU1	
	91424-24J-822	TUBE, FUEL, 4.5X430(FKM)	1	-	-	-	1085295 VS17, VS19, VSD1, VSD2	
	95001-45140-40	TUBE, FUEL, 4.5X140 (95001-45001-60M)	1	-	-	-	1080500 LX2, LX4, PXU, QG2, QH26, QHQ4, QX2, QX26, QX4, QX7, QX9, QXB2, QXU, SHQ4, SM12, SMC4, SX4, SX7, SX9, SXU, TX2, TX4, TXU, TXU1, VGG2, VGS5, VGS9, VSD, VSD7, VSD9, VX2, VX4, VXU, VXU1	
	95001-45430-40	TUBE, FUEL, 4.5X430 (95001-45001-60M)	1	-	-	-	1085296 VS17, VS19, VSD1, VSD2	
	91424-24F-801	TUBE, FUEL, 4.5X140(FKM)	1	-	-	-	1080500 LX2, LX4, PXU, QG2, QH26, QHQ4, QX2, QX26, QX4, QX7, QX9, QXB2, QXU, SHQ4, SM12, SMC4, SX4, SX7, SX9, SXU, TX2, TX4, TXU, TXU1, VGG2, VGS5, VGS9, VSD, VSD7, VSD9, VX2, VX4, VXU, VXU1	
	91424-24J-821	TUBE, FUEL, 4.5X430(FKM)	1	-	-	-	1085296 VS17, VS19, VSD1, VSD2	
	91424-24J-812	TUBE, FUEL, 4.5X300(FKM)	-	1	-	1	SWG4	
	91424-24J-822	TUBE, FUEL, 4.5X430(FKM)	-	-	-	1	VEE9, VS19	
	91424-24F-802	TUBE, FUEL, 4.5X140(FKM)	-	-	-	1	VENN, VGGN	
16	95002-02080	CLIP, TUBE(B8)	2	-	-	-	1080499 LX2, LX4, PXU, QG2, QH26, QHQ4, QX2, QX26, QX4, QX7, QX9, QXB2, QXU, SHQ4, SM12, SMC4, SX4, SX7, SX9, SXU, TX2, TX4, TXU, TXU1, VGG2, VGS5, VGS9, VSD, VSD7, VSD9, VX2, VX4, VXU, VXU1	
			2	-	-	-	1085295 VS17, VS19, VSD1, VSD2	
			4	-	-	-	1104342 VPM4, VPM8, VPM9	
17	95002-40800-08	CLAMP, TUBE(D8)	2	2	-	-	HX2, HXU, LXAU, QH4, QMP4, QXC9, QXD4, QXD9, QXE2, QXE4, QXE5, QXE6, RH2, RHQ4, RX4, RXU, SAR, SHQ2, SMC2, SMCR, SWG4, SXE4, SXE5, TXD1, TXDU, VEE9, VGGN	
			2	-	-	-	1080500 LX2, LX4, PXU, QG2, QH26, QHQ4, QX2, QX26, QX4, QX7, QX9, QXB2, QXU, SHQ4, SM12, SMC4, SX4, SX7, SX9, SXU, TX2, TX4, TXU, TXU1, VGG2, VGS5, VGS9, VSD, VSD7, VSD9, VX2, VX4, VXU, VXU1	
			2	-	-	-	1085296 VS17, VS19, VSD1, VSD2	
			-	-	-	2	SWG4, VEE9, VENN, VGGN, VS19	
18	95002-40800-08	CLAMP, TUBE(D8)	4	-	-	-	1104343 VPM4, VPM8, VPM9	
			-	-	-	4	VPM4	
19	17620-24H-020	CAP COMP., FUEL FILLER	1	1	-	-	HX2, HXU, QH4, QXC9, QXD4, QXD9, QXE2, QXE4, QXE5, QXE6, RH2, RHQ4, RX4, RXU, SAR, SHQ2, SMC2, SMCR, SXE4, SXE5	
	17620-24H-000	1	-	-	-	1377258 QMP4	
	17620-24H-010	1	-	-	-	1411432 TXD1, TXDU	
	17620-24H-000	1	-	-	-	1259679 1377258 LX2, LX4, LXAU, PXU, QG2, QH26, QHQ4, QX2, QX26, QX4, QX7, QX9, QXB2, QXU, SHQ4, SM12, SMC4, SX4, SX7, SX9, SXU, TX2, TX4, TXU, TXU1, VGS5, VGS9, VSD, VSD7, VSD9, VX2, VX4, VXU, VXU1	
	17620-24H-010	1	-	-	-	1377259 1411432 LX2, LX4, LXAU, PXU, QG2, QH26, QHQ4, QMP4, QX2, QX26, QX4, QX7, QX9, QXB2, QXU, SHQ4, SM12, SMC4, SX4, SX7, SX9, SXU, TX2, TX4, TXU, TXU1, VGS5, VGS9, VSD, VSD7, VSD9, VX2, VX4, VXU, VXU1	
	17620-24H-020	1	-	-	-	1411433 LX2, LX4, LXAU, PXU, QG2, QH26, QHQ4, QMP4, QX2, QX26, QX4, QX7, QX9, QXB2, QXU, SHQ4, SM12, SMC4, SX4, SX7, SX9, SXU, TX2, TX4, TXD1, TXDU, TXU, TXU1, VGS5, VGS9, VSD, VSD7, VSD9, VX2, VX4, VXU, VXU1	



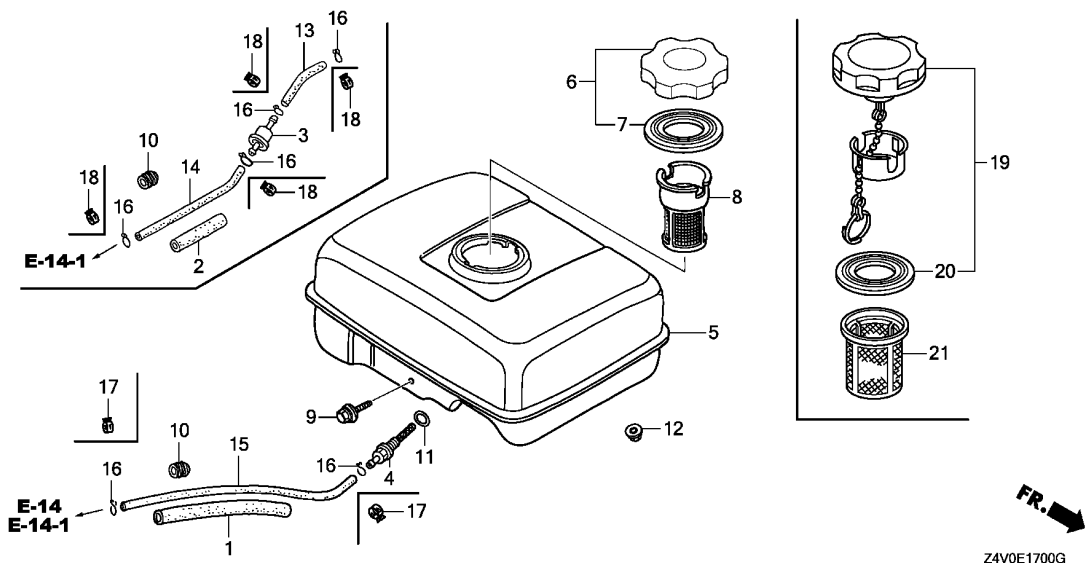

Z4V0E1700G

Ref. No.	Part No.	Description	Reqd. QTY				Serial No.	Parts catalogue code
			GX 200 UT	GX 200 RT	GX 200 UT2	GX 200 RT2		
20	17631-Z0T-801	PACKING, FUEL FILLER CAP (39X62X3) (RADICON)	1	1	-	-	-----	HX2, HXU, QH4, QXC9, QXD4, QXD9, QXE2, QXE4, QXE5, QXE6, RH2, RHQ4, RX4, RXU, SAR, SHQ2, SMC2, SMCR, SXE4, SXE5
	17631-Z4H-800	PACKING, FUEL FILLER CAP (39X62X3)	1	-	-	-	-----	1377258 QMP4
	17631-Z0T-801	PACKING, FUEL FILLER CAP (39X62X3) (RADICON)	1	-	-	-	-----	1411432 TXD1, TXDU
	17631-Z4H-800	PACKING, FUEL FILLER CAP (39X62X3)	1	-	-	-	1259679	1377258 LX2, LX4, LXAU, PXU, QG2, QH26, QHQ4, QX2, QX26, QX4, QX7, QX9, QXB2, QXU, SHQ4, SM12, SMC4, SX4, SX7, SX9, SXU, TX2, TX4, TXU, TXU1, VGS5, VGS9, VSD, VSD7, VSD9, VX2, VX4, VXU, VXU1
	17631-Z4H-800	PACKING, FUEL FILLER CAP (39X62X3)	1	-	-	-	1377259	1411432 LX2, LX4, LXAU, PXU, QG2, QH26, QHQ4, QMP4, QX2, QX26, QX4, QX7, QX9, QXB2, QXU, SHQ4, SM12, SMC4, SX4, SX7, SX9, SXU, TX2, TX4, TXU, TXU1, VGS5, VGS9, VSD, VSD7, VSD9, VX2, VX4, VXU, VXU1
	17631-Z0T-801	PACKING, FUEL FILLER CAP (39X62X3) (RADICON)	1	-	-	-	1411433	----- LX2, LX4, LXAU, PXU, QG2, QH26, QHQ4, QMP4, QX2, QX26, QX4, QX7, QX9, QXB2, QXU, SHQ4, SM12, SMC4, SX4, SX7, SX9, SXU, TX2, TX4, TXD1, TXDU, TXU, TXU1, VGS5, VGS9, VSD, VSD7, VSD9, VX2, VX4, VXU, VXU1
21	17672-Z4H-000	FILTER, FUEL	1	1	-	-	-----	QH4, SAR
			1	-	-	-	1259679	----- SM12

E-17-1

FUEL TANK(2)

F12

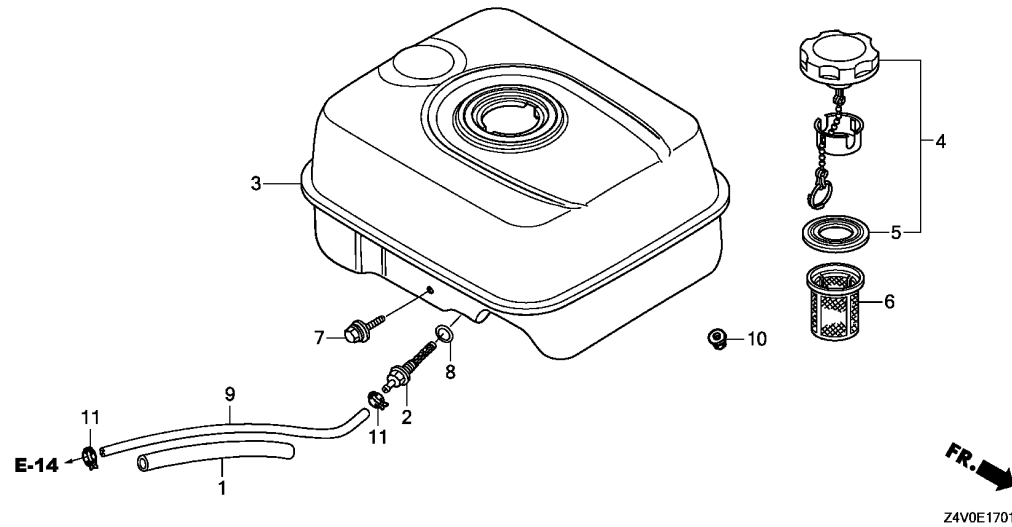

Ref. No.	L.O.N. (Relative ref. Number)	Description	F.R.T.
----------	-------------------------------	-------------	--------

Ref. No.	Part No.	Description	Reqd. QTY				Serial No.	Parts catalogue code
			GX 200 UT	GX 200 RT	GX 200 UT2	GX 200 RT2		
1	16854-ZH8-000	RUBBER, SUPPORTER(107MM)	-	-	1	-		
2	16955-ZE1-010	JOINT, FUEL TANK	-	-	1	-		
3	17510-Z4M-000ZA	TANK COMP., FUEL *NH31*.....MCKINLEY WHITE	-	-	1	-	HX2,LX4,LXAU,PXU,QG2,QH26,QHQ4,QMP4,QX2,QX4,QX9,QXAG,QXB2,QXC9 QXD4,QXD9,QXE2,QXE4,QXE5,RH2,RHQ4,RX4,RXU,SAR,SHQ4,SM12,SM24 SMC4,SMCR,SX4,SX9,SXE5,SXU,TX2,TXD1,TXDU,VGS5,VSD9,VXU,VXU1	
	17510-Z4M-000ZB	*NH1*.....BLACK	-	-	1	-	PXU,QG2,QH26,QHQ4,QX2,QX4,QX9,QXB2,QXC9,SHQ4,SM12,SM14,SMC4 SMCR,SX4,SX9,SXW9,TX2,VSD9,VXU,VXU1	
4	17620-Z4H-020	CAP COMP., FUEL FILLER	-	-	1	-	HX2,LX4,LXAU,PXU,QG2,QH26,QHQ4,QMP4,QX2,QX4,QX9,QXB2,QXD4,QXD9 QXE2,QXE4,QXE5,RH2,RHQ4,RX4,RXU,SAR,SHQ4,SM12,SM14,SM24,SMC4 SX4,SX9,SXE5,SXU,TX2,TXD1,TXDU,VGS5,VSD9,VXU,VXU1	
	17620-Z4H-030	-	-	1	-	QXAG,QXC9,SMCR,SXW9	
5	17631-Z0T-801	PACKING, FUEL FILLER CAP (39X62X3)(RADICON)	-	-	1	-		
6	17672-Z4H-000	FILTER, FUEL	-	-	1	-	SAR,SM12,SM14,SM24	
7	90004-ZLO-003	BOLT, FLANGE, 6X34	-	-	1	-		
8	91353-671-004	O-RING, 14MM(NOK)	-	-	1	-		
9	91424-Z4M-003	TUBE, FUEL, 4.5X145(FKM)	-	-	1	-		
10	94050-06000	NUT, FLANGE, 6MM	-	-	2	-		
11	95002-40800-08	CLAMP, TUBE(D8)	-	-	2	-		

2

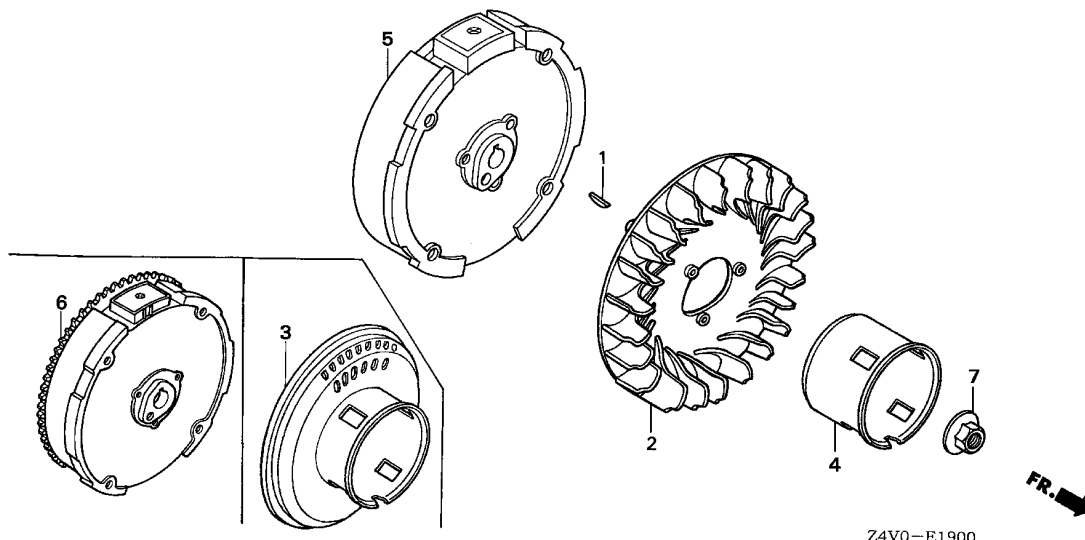

Ref. No.	L.O.N.	(Relative ref. Number) Description	F.R.T.
----------	--------	------------------------------------	--------

Ref. No.	Part No.	Description	Reqd. QTY				Serial No.	Parts catalogue code
			GX 200 UT	GX 200 RT	GX 200 UT2	GX 200 RT2		
1	13331-357-000	KEY, SPECIAL WOODRUFF, 25X18	1	1	1	1		
2	19511-ZE1-000	FAN, COOLING	1	1	1	1		
3	28450-ZL0-801	PULLEY COMP., STARTER	1	1	1	-	----- QXB2, SAR, SMC2, SMC4, SMCR	
4	28451-ZL0-801	PULLEY, STARTER	1	1	1	1	----- HX2, HXU, LX2, LX4, LXAU, PXU, QG2, QH26, QH4, QHQ4, QMP4, QX2, QX26, QX4, QX7, QX9, QXAG, QXC9, QXD4, QXD9, QXE2, QXE4, QXE5, QXE6, QXU, RDG4, RH2, RHG4, RHQ4, RMG2, RX4, RXU, SHQ2, SHQ4, SM12, SM14, SM24, SX4, SX7, SX9, SXE4, SXE5, SXU, SXW9, TX2, TX4, TXD1, TXDU, TXU, TXU1, VEE9, VENN, VGG2, VGGN, VGS5, VGS9, VPM4, VPM8, VPM9, VS17, VS19, VSD, VSD1, VSD2, VSD7, VSD9, VX2, VX4, VXU, VXU1	
	28451-ZL0-000	-	1	-	1	----- SWG4	
5	31100-ZE7-010	FLYWHEEL COMP.(STD.)	1	1	1	1	----- HX2, HXU, LX2, LX4, PXU, QH26, QHQ4, QMP4, QX2, QX26, QX4, QX7, QX9, QXAG, QXB2, QXC9, QXD4, QXD9, QXU, RH2, RHG4, RHQ4, RX4, RXU, SAR, SHQ2, SHQ4, SM12, SM14, SM24, SX4, SX7, SX9, SXU, SXW9, TX2, TX4, TXDU, TXU, VGG2, VGGN, VGS5, VGS9, VPM4, VPM8, VPM9, VS17, VS19, VSD, VSD1, VSD2, VSD7, VSD9, VX2, VX4, VXU, VXU1	
	31110-ZL0-811	FLYWHEEL COMP.(LAMP)	1	1	1	1	----- LXAU, RDG4, RMG2, SMC2, SMC4, VENN	
6	31110-ZL0-821	FLYWHEEL COMP.(START)	1	1	1	1	----- QXE2, QXE4, QXE6, SWG4, SXE4, TXD1, TXU1, VEE9	
	31110-ZL0-U52	FLYWHEEL COMP.(SEL-7A)	1	-	1	-	----- QG2, QH4, QXE5, SMC, SXE5	
7	90201-ZOT-800	NUT, SPECIAL, 14MM	1	1	1	1		

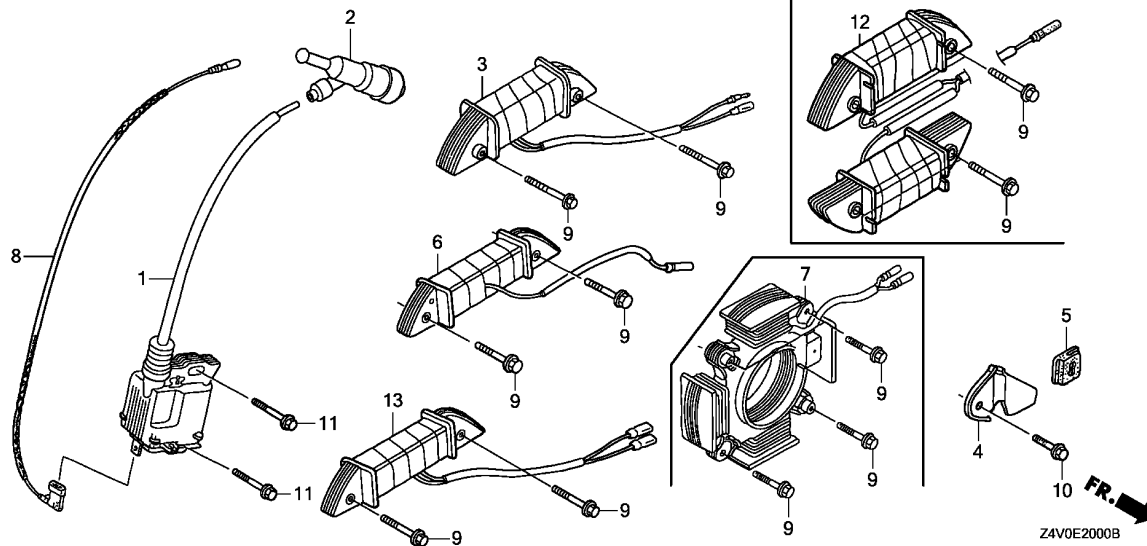

Ref. No.	L.O.N.	(Relative ref. Number) Description	F.R.T.
----------	--------	------------------------------------	--------

Ref. No.	Part No.	Description	Reqd. QTY				Serial No.	Parts catalogue code
			GX 200 UT	GX 200 RT	GX 200 UT2	GX 200 RT2		
1	30500-Z0T-802	COIL ASSY., IGNITION	1	1	-	-	-----	HX2,HXU,LXAU,QH4,QMP4,QXC9,QXD4,QXD9,QXE2,QXE4,QXE5,QXE6,RH2,RHG4,RHQ4,RMG2,RX4,RXU,SAR,SHQ2,SMC2,SMCR,SWG4,SXE4,SXE5,TXD1, TXDU,VEE9,VGGN
	30500-Z0T-801	1	-	-	-	-----	LX2,LX4,PXU,QG2,QH26,QHQ4,QX2,QX26,QX4,QX7,QX9,QXB2,QXU,SHQ4, SM12,SMC4,SX4,SX7,SX9,SXU, TX2, TX4, TXU, TXU1,VGG2,VGS5,VGS9,VPM4, VPM8,VPM9,VS17,VS19,VSD,VSD1,VSD2,VSD7,VSD9,VX2,VX4,VXU,VXU1
	30500-Z0T-802	-	-	1	1	-----	VEE9
2	30700-Z0T-811	CAP ASSY., NOISE SUPPRESSOR	1	1	1	1	-----	HX2,HXU,LX2,LX4,LXAU,PXU,QG2,QH26,QH4,QHQ4,QMP4,QX2,QX26,QX4, QX7,QX9,QXAG,QXB2,QXC9,QXD4,QXD9,QXE2,QXE4,QXE5,QXE6,QXU,RDG4, RH2,RHG4,RHQ4,RMG2,RX4,RXU,SAR,SHQ2,SHQ4,SM12,SM14,SM24,SMC2, SMC4,SMCR,SWG4,SX4,SX7,SX9,SXE4,SXE5,SXU,SXW9, TX2, TX4, TXD1, TXDU, TXU, TXU1, VENN, VGG2, VGGN, VGS5, VGS9, VPM8, VPM9, VS17, VSD, VSD1, VSD2, VSD7, VSD9, VX2, VX4, VXU, VXU1
	30700-ZF5-013	1	-	-	-	-----	VEE9
	30700-Z0T-811	1	-	-	-	1295810	VPM4, VS19
	30700-ZF5-013	1	-	-	-	1295811	VPM4, VS19
	30700-ZF5-013	-	-	-	1	-----	VEE9,VPM4, VS19
3	31510-ZE1-811	COIL ASSY., LAMP(12V/25W)	1	-	1	1	-----	RDG4, SMC2, SMC4
4	31511-ZE1-000	CLAMPER, CORD	1	1	1	1	-----	LXAU, QG2, QH4, QXE2, QXE4, QXE5, QXE6, RDG4, RMG2, SMC2, SMC4, SMCR, SXE4, SXE5, TXD1, TXU1, VEE9, VENN
5	31512-ZE1-000	GROMMET, CORD	1	1	1	1	-----	LXAU, QG2, QH4, QXE2, QXE4, QXE5, QXE6, RDG4, RMG2, SMC2, SMC4, SMCR, SWG4, SXE4, SXE5, TXD1, TXU1, VEE9, VENN
6	31630-ZE1-013	COIL ASSY., CHARGE(1A)	1	-	1	1	-----	QXE2, QXE4, QXE6, SXE4, TXD1, TXU1, VEE9
7	31630-ZH8-W01	COIL ASSY., CHARGE(12V-7A)	1	-	1	-	-----	QG2, QH4, QXE5, SMCR, SXE5



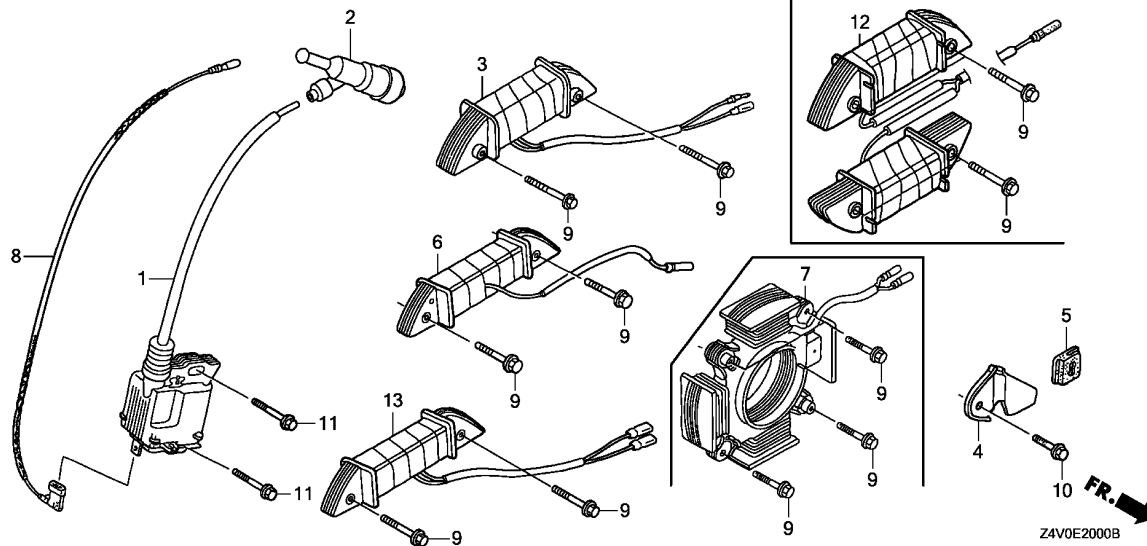

Ref. No.	Part No.	Description	Reqd. QTY				Serial No.	Parts catalogue code
			GX 200 UT	GX 200 RT	GX 200 UT2	GX 200 RT2		
8	36101-ZE1-010	CORD, STOP SWITCH(370MM)	1	1	1	1	-----	HX2, HXU, LX2, LX4, LXAU, PXU, QG2, QH26, QHQ4, QMP4, QX2, QX26, QX4, QX7, QX9, QXAG, QXB2, QXC9, QXD4, QXD9, QXU, RDG4, RH2, RHG4, RHQ4, RMG2, RX4, RXU, SAR, SHQ2, SHQ4, SM12, SM14, SM24, SMC2, SMC4, SMCR, SX4, SX7, SX9, SXU, SXW9, TX2, TX4, TXDU, TXU, VENN, VGG2, VGGN, VGS5, VGS9, VPM4, VPM8, VPM9, VS17, VS19, VSD, VSD1, VSD2, VSD7, VSD9, VX2, VX4, VXU, VXU1
	36101-ZB2-010	CORD, STOP SWITCH(395MM)	1	1	1	1	-----	QH4, QXE2, QXE4, QXE5, QXE6, SWG4, SXE4, SXE5, TXD1, TXU1, VEE9
9	90015-883-000	BOLT, FLANGE, 6X28(CT200) ...	2	-	2	-	-----	QXE2, QXE4, QXE6, SMC2, SMC4, SXE4, TXD1, TXU1, VEE9
			4	-	-	-	-----	LXAU, QG2, QH4, QXE5, SMCR, SXE5
			-	4	-	4	-----	RMG2
			-	-	4	-	-----	LXAU, QG2, QXE5, SMCR, SXE5
10	90019-883-000	BOLT, FLANGE, 5X10	1	1	1	1	-----	RDG4, VEE9, VENN
			1	1	1	1	-----	LXAU, QG2, QH4, QXE2, QXE4, QXE5, QXE6, RDG4, RMG2, SMC2, SMC4, SMCR, SXE4, SXE5, TXD1, TXU1, VEE9, VENN
11	90121-952-000	BOLT, FLANGE, 6X25(CT200) ...	2	2	2	2	-----	LXAU, RMG2
12	31510-ZE1-711	COIL ASSY., LAMP(12V/50W) ...	1	1	1	1	-----	VENN
13	31630-ZLO-V31	COIL ASSY., CHARGE	-	-	-	1	-----	VENN

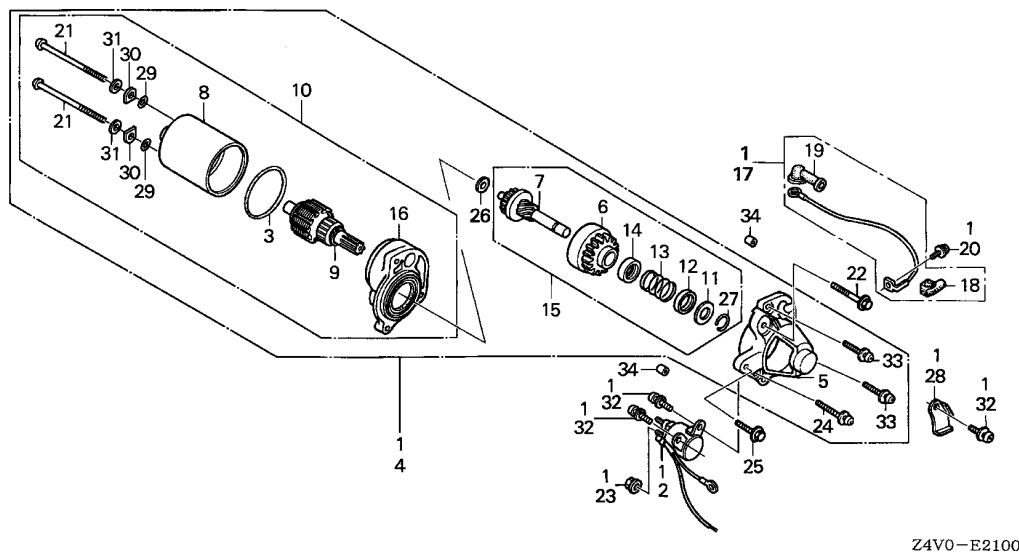

Ref. No.	L.O.N. (Relative ref. Number)	Description	F.R.T.
----------	-------------------------------	-------------	--------

Ref. No.	Part No.	Description	Reqd. QTY				Serial No.	Parts catalogue code
			GX 200 UT	GX 200 RT	GX 200 UT2	GX 200 RT2		
1	31200-ZL0-811	MOTOR ASSY., STARTER	1	1	-	-	QH4,QXE2,QXE4,QXE5,QXE6,SWG4,SXE4,SXE5,TXD1,TXU1,VEE9	
2	31204-ZE1-013	SWITCH COMP., STARTING MAGNET	1	1	1	1	QH4,QXE2,QXE4,QXE5,QXE6,SWG4,SXE4,SXE5,TXD1,VEE9	
	31204-ZE1-003	1	-	-	-	TXU1	
3	31206-KN7-670	O-RING	1	1	-	-	QH4,QXE2,QXE4,QXE5,QXE6,SWG4,SXE4,SXE5,TXD1,TXU1,VEE9	
	31206-Z4M-003	-	-	1	1	QXE2,QXE4,QXE5,SWG4,SXE5,TXD1,VEE9	
4	31210-ZE1-723	MOTOR UNIT, STARTER(SM-11205) (181MM)	1	1	-	-	QH4,QXE2,QXE4,QXE5,QXE6,SWG4,SXE4,SXE5,TXD1,TXU1,VEE9	
	31210-Z4M-003	MOTOR UNIT, STARTER	-	-	1	1	QXE2,QXE4,QXE5,SWG4,SXE5,TXD1,VEE9	
5	31212-ZE1-003	COVER COMP., GEAR	1	1	-	-	QH4,QXE2,QXE4,QXE5,QXE6,SWG4,SXE4,SXE5,TXD1,TXU1,VEE9	
	31212-Z4M-003	-	-	1	1	QXE2,QXE4,QXE5,SWG4,SXE5,TXD1,VEE9	
6	31214-ZE1-003	PINION ASSY.	1	1	-	-	QH4,QXE2,QXE4,QXE5,QXE6,SWG4,SXE4,SXE5,TXD1,TXU1,VEE9	
	31214-Z4M-003	-	-	1	1	QXE2,QXE4,QXE5,SWG4,SXE5,TXD1,VEE9	
7	31215-ZE1-003	SHAFT UNIT, GEAR	1	1	-	-	QH4,QXE2,QXE4,QXE5,QXE6,SWG4,SXE4,SXE5,TXD1,TXU1,VEE9	
	31215-Z4M-003	-	-	1	1	QXE2,QXE4,QXE5,SWG4,SXE5,TXD1,VEE9	
8	31216-ZE1-731	YOKE ASSY.	1	1	-	-	QH4,QXE2,QXE4,QXE5,QXE6,SWG4,SXE4,SXE5,TXD1,TXU1,VEE9	
	31216-Z4M-003	-	-	1	1	QXE2,QXE4,QXE5,SWG4,SXE5,TXD1,VEE9	
9	31217-ZE1-722	ROTOR ASSY.	1	1	-	-	QH4,QXE2,QXE4,QXE5,QXE6,SWG4,SXE4,SXE5,TXD1,TXU1,VEE9	
	31217-Z4M-003	-	-	1	1	QXE2,QXE4,QXE5,SWG4,SXE5,TXD1,VEE9	
10	31220-ZE1-722	MOTOR ONLY	1	1	-	-	QH4,QXE2,QXE4,QXE5,QXE6,SWG4,SXE4,SXE5,TXD1,TXU1,VEE9	
	31220-Z4M-003	-	-	1	1	QXE2,QXE4,QXE5,SWG4,SXE5,TXD1,VEE9	
11	31221-ZE1-003	PIECE A, STOPPER	1	1	-	-	QH4,QXE2,QXE4,QXE5,QXE6,SWG4,SXE4,SXE5,TXD1,TXU1,VEE9	
	31221-Z4M-003	-	-	1	1	QXE2,QXE4,QXE5,SWG4,SXE5,TXD1,VEE9	
12	31222-ZE1-003	PIECE B, STOPPER	1	1	-	-	QH4,QXE2,QXE4,QXE5,QXE6,SWG4,SXE4,SXE5,TXD1,TXU1,VEE9	
	31222-Z4M-003	-	-	1	1	QXE2,QXE4,QXE5,SWG4,SXE5,TXD1,VEE9	
13	31223-ZE1-003	SPRING, RETURN	1	1	-	-	QH4,QXE2,QXE4,QXE5,QXE6,SWG4,SXE4,SXE5,TXD1,TXU1,VEE9	
	31223-Z4M-003	-	-	1	1	QXE2,QXE4,QXE5,SWG4,SXE5,TXD1,VEE9	
14	31224-ZE1-003	COVER, SPRING	1	1	-	-	QH4,QXE2,QXE4,QXE5,QXE6,SWG4,SXE4,SXE5,TXD1,TXU1,VEE9	



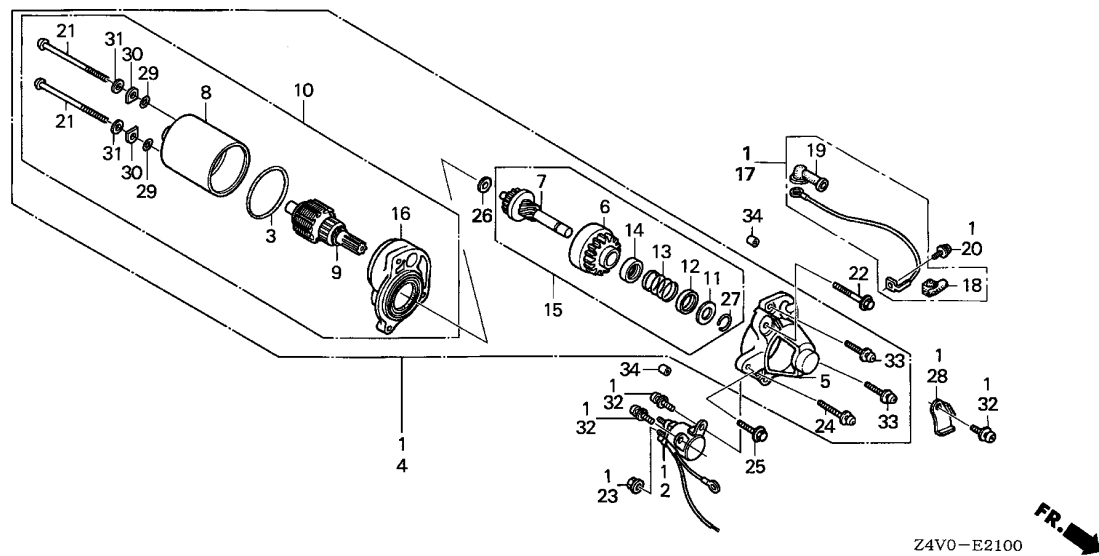

Z4V0-E2100

Ref. No.	Part No.	Description	Reqd. QTY				Serial No.	Parts catalogue code
			GX 200 UT	GX 200 RT	GX 200 UT2	GX 200 RT2		
14)	31224-Z4M-003	COVER, SPRING	-	-	1	1	-----	QXE2,QXE4,QXE5,SWG4,SXE5,TXD1,VEE9
15	31230-ZE1-003	GEAR ASSY.	1	1	-	-	-----	QH4,QXE2,QXE4,QXE5,QXE6,SWG4,SXE4,SXE5,TXD1,TXU1,VEE9
	31230-Z4M-003	-	-	1	1	-----	QXE2,QXE4,QXE5,SWG4,SXE5,TXD1,VEE9
16	31235-ZE1-013	BRACKET COMP., FR.	1	1	-	-	-----	QH4,QXE2,QXE4,QXE5,QXE6,SWG4,SXE4,SXE5,TXD1,TXU1,VEE9
	31235-Z4M-003	-	-	1	1	-----	QXE2,QXE4,QXE5,SWG4,SXE5,TXD1,VEE9
17	32410-ZE1-010	CORD, MAGNET SWITCH	1	1	1	1	-----	QH4,QXE2,QXE4,QXE5,QXE6,SWG4,SXE4,SXE5,TXD1,VEE9
	32410-ZE1-000	1	-	-	-	1368432	TXU1
	32410-ZE1-010	1	-	-	-	1368433	TXU1
18	32411-ZE1-000	COVER, MAGNETIC SWITCH	1	1	1	1	-----	QH4,QXE2,QXE4,QXE5,QXE6,SWG4,SXE4,SXE5,TXD1,TXU1,VEE9
19	32411-253-000	COVER, STARTER MOTOR TERMINAL	1	1	1	1	-----	QH4,QXE2,QXE4,QXE5,QXE6,SWG4,SXE4,SXE5,TXD1,TXU1,VEE9
20	90010-ZE1-003	SCREW-WASHER, 5X8	1	1	-	-	-----	QH4,QXE2,QXE4,QXE5,QXE6,SWG4,SXE4,SXE5,TXD1,TXU1,VEE9
	90010-Z4M-003	SCREW, PAN, 5X8	-	-	1	1	-----	QXE2,QXE4,QXE5,SWG4,SXE5,TXD1,VEE9
21	90012-ZE1-721	BOLT, SETTING	2	2	-	-	-----	QH4,QXE2,QXE4,QXE5,QXE6,SWG4,SXE4,SXE5,TXD1,TXU1,VEE9
	90012-Z4M-003	-	-	2	2	-----	QXE2,QXE4,QXE5,SWG4,SXE5,TXD1,VEE9
22	90017-883-000	BOLT, FLANGE, 6X32(CT200) ...	1	1	1	1	-----	QH4,QXE2,QXE4,QXE5,QXE6,SWG4,SXE4,SXE5,TXD1,TXU1,VEE9
23	90071-MB0-000	NUT-WASHER, 6MM	2	2	-	-	-----	QH4,QXE2,QXE4,QXE5,QXE6,SWG4,SXE4,SXE5,TXD1,TXU1,VEE9
	90201-Z4M-003	-	-	2	2	-----	QXE2,QXE4,QXE5,SWG4,SXE5,TXD1,VEE9
24	90115-GB4-700	SCREW-WASHER, 5X30	1	1	-	-	-----	QH4,QXE2,QXE4,QXE5,QXE6,SWG4,SXE4,SXE5,TXD1,TXU1,VEE9
	31236-Z4M-003	-	-	1	1	-----	QXE2,QXE4,QXE5,SWG4,SXE5,TXD1,VEE9
25	90121-952-000	BOLT, FLANGE, 6X25(CT200) ...	1	1	1	1	-----	QH4,QXE2,QXE4,QXE5,QXE6,SWG4,SXE4,SXE5,TXD1,TXU1,VEE9
26	90502-187-701	WASHER, PINION	1	1	-	-	-----	QH4,QXE2,QXE4,QXE5,QXE6,SWG4,SXE4,SXE5,TXD1,TXU1,VEE9
	31237-Z4M-003	-	-	1	1	-----	QXE2,QXE4,QXE5,SWG4,SXE5,TXD1,VEE9
27	90603-ZE1-003	CIRCLIP, 10.2MM	1	1	-	-	-----	QH4,QXE2,QXE4,QXE5,QXE6,SWG4,SXE4,SXE5,TXD1,TXU1,VEE9
	90603-Z4M-003	-	-	1	1	-----	QXE2,QXE4,QXE5,SWG4,SXE5,TXD1,VEE9
28	90631-ZE1-003	HOLDER, HARNESS	1	1	-	-	-----	QH4,QXE2,QXE4,QXE5,QXE6,SWG4,SXE4,SXE5,TXD1,TXU1,VEE9
	90631-Z4M-801	-	-	1	1	-----	QXE2,QXE4,QXE5,SWG4,SXE5,TXD1,VEE9

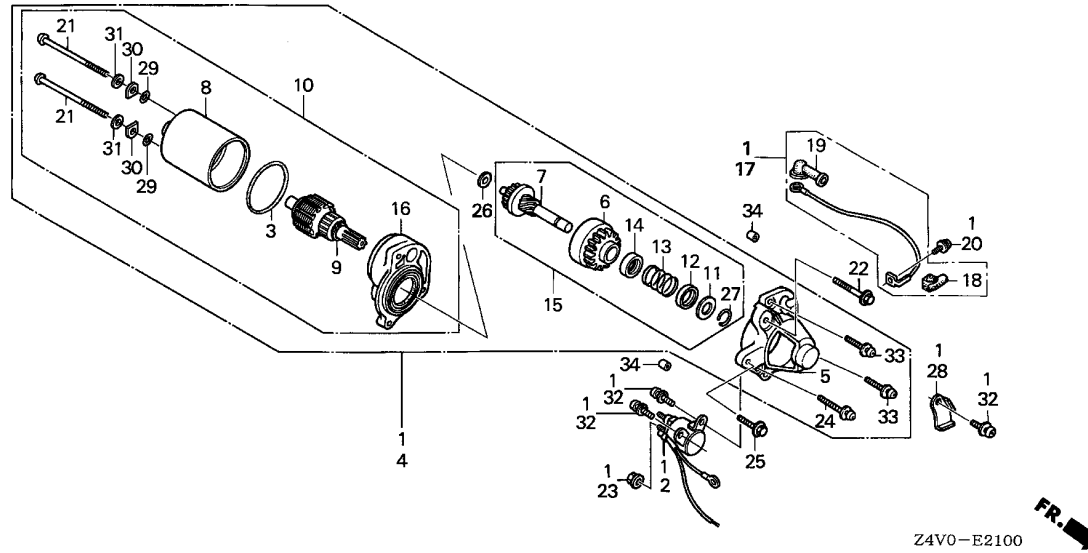

Ref. No.	Part No.	Description	Reqd. QTY				Serial No.	Parts catalogue code
			GX 200	GX 200	GX 200	GX 200		
			UT	RT	UT2	RT2		
29	91301-ZE1-003	O-RING	2	2	-	-	QH4,QXE2,QXE4,QXE5,QXE6,SWG4,SXE4,SXE5,TXD1,TXU1,VEE9	
	91301-Z4M-003	-	-	2	2	QXE2,QXE4,QXE5,SWG4,SXE5,TXD1,VEE9	
30	91402-ZE6-003	WASHER, SPECIAL	2	2	-	-	QH4,QXE2,QXE4,QXE5,QXE6,SWG4,SXE4,SXE5,TXD1,TXU1,VEE9	
	91402-Z4M-003	-	-	2	2	QXE2,QXE4,QXE5,SWG4,SXE5,TXD1,VEE9	
31	91403-ZE6-003	WASHER, SPRING	2	2	-	-	QH4,QXE2,QXE4,QXE5,QXE6,SWG4,SXE4,SXE5,TXD1,TXU1,VEE9	
	91403-Z4M-003	-	-	2	2	QXE2,QXE4,QXE5,SWG4,SXE5,TXD1,VEE9	
32	93892-05014-08	SCREW-WASHER, 5X14	3	3	3	3	QH4,QXE2,QXE4,QXE5,QXE6,SWG4,SXE4,SXE5,TXD1,TXU1,VEE9	
33	93892-05020-08	SCREW-WASHER, 5X20	2	2	2	2	QH4,QXE2,QXE4,QXE5,QXE6,SWG4,SXE4,SXE5,TXD1,TXU1,VEE9	
34	94301-08100	DOWEL PIN, 8X10	2	2	2	2	QH4,QXE2,QXE4,QXE5,QXE6,SWG4,SXE4,SXE5,TXD1,TXU1,VEE9	



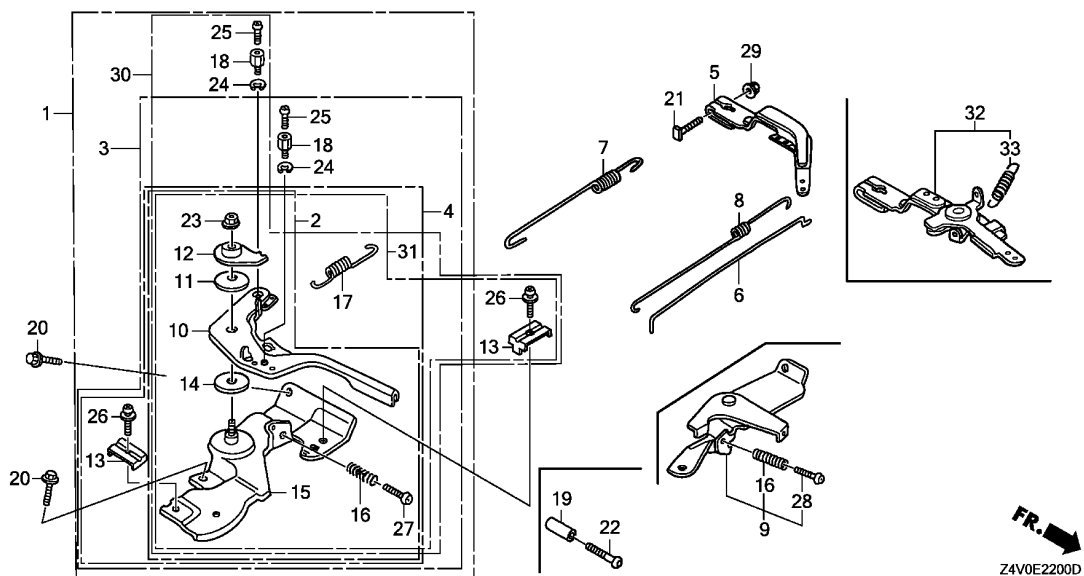

Ref. No.	L.O.N.	(Relative ref. Number) Description	F.R.T.
----------	--------	------------------------------------	--------



Ref. No.	Part No.	Description	Reqd. QTY				Serial No.	Parts catalogue code
			GX 200 UT	GX 200 RT	GX 200 UT2	GX 200 RT2		
1	16500-ZH8-U43 16500-Z4M-309	CONTROL ASSY. (NORTON) CONTROL ASSY. (NORTON) (COO) (FOR U.S.A.)	1	1	-	-	SAR, SM12	
2	16500-ZH8-030 16500-Z4M-305	CONTROL ASSY. CONTROL ASSY. (COO) (FOR U.S.A.)	1	-	1	-	SAR, SM12, SM14, SM24 PXU, TX2, TX4, TXD1, TXDU, TXU, TXU1, VGG2, VGGN, VX2, VX4	
3	16500-ZH8-813 16500-ZH8-853 16500-Z4M-306	CONTROL ASSY. (REMOTE/INTERNAL) CONTROL ASSY. (CYCLONE) CONTROL ASSY. (REMOTE INTL) (COO) (FOR U.S.A.)	1	-	-	-	PXU, TX2, TXD1, TXDU, VGGN QXB2 QXC9 QXB2	
4	16500-Z4M-407 16500-ZH8-823 16500-Z4M-307	CONTROL ASSY. (CYCLONE) (COO) (FOR U.S.A.) CONTROL ASSY. (REMOTE) CONTROL ASSY. (REMOTE) (COO) (FOR U.S.A.)	-	-	1	-	QXC9, SXW9 HX2, HXU, LX2, LX4, LXAU, QG2, QH26, QHQ4, QX2, QX26, QX4, QX7, QX9, QXD4 QXD9, QXE2, QXE4, QXE5, QXE6, QXU, RH2, RHG4, RHQ4, RMG2, RX4, RXU, SHQ2 SHQ4, SMC2, SMC4, SMCR, SX4, SX7, SX9, SXE4, SXE5, SXU	
5	16551-ZL0-000	ARM, GOVERNOR	1	1	1	1	HX2, HXU, LX2, LX4, LXAU, PXU, QG2, QH26, QH4, QHQ4, QMP4, QX2, QX26, QX4 QX7, QX9, QXAG, QXB2, QXC9, QXD4, QXD9, QXE2, QXE4, QXE5, QXE6, QXU, RDG4 RH2, RHG4, RHQ4, RMG2, RX4, RXU, SAR, SHQ2, SHQ4, SM12, SM14, SM24, SMC2 SMC4, SMCR, SWG4, SX4, SX7, SX9, SXE4, SXE5, SXU, SXW9, TX2, TX4, TXD1 TXDU, TXU, TXU1, VEE9, VGG2, VGGN, VGS5, VGS9, VPM4, VPM8, VPM9, VS17 VSD1, VSD2, VSD7, VSD9, VX2, VX4, VXU, VXU1	
6	16555-ZE1-000	ROD, GOVERNOR	1	1	-	-		

Ref. No.	Part No.	Description	Reqd. QTY				Serial No.	Parts catalogue code
			GX 200 UT	GX 200 RT	GX 200 UT2	GX 200 RT2		
(6)	16555-Z4M-000	ROD, GOVERNOR	-	-	1	1	-----	HX2, LX4, LXAU, PXU, QG2, QH26, QHQ4, QMP4, QX2, QX4, QX9, QXAG, QXB2, QXC9, QXD4, QXD9, QXE2, QXE4, QXE5, RDG4, RH2, RHG4, RHQ4, RMG2, RX4, RXU, SAR, SHQ4, SM12, SM14, SM24, SMC4, SMCR, SWG4, SX4, SX9, SXE5, SXU, SXW9, TX2, TXD1, TXDU, VEE9, VGG2, VGGN, VGS5, VPM4, VS19, VSD9, VXU, VXU1
	16555-ZL0-V30	-	-	-	1	-----	VENN
7	16561-ZL0-000	SPRING, GOVERNOR	1	1	1	1	-----	HX2, HXU, LX2, LX4, LXAU, PXU, QG2, QH26, QH4, QHQ4, QMP4, QX2, QX26, QX4, QX7, QX9, QXAG, QXB2, QXC9, QXD4, QXD9, QXE2, QXE4, QXE5, QXE6, QXU, RDG4, RH2, RHG4, RHQ4, RMG2, RX4, RXU, SAR, SHQ2, SHQ4, SM12, SM14, SM24, SMC2, SMC4, SMCR, SWG4, SX4, SX7, SX9, SXE4, SXE5, SXU, SXW9, TX2, TX4, TXD1, TXDU, TXU, TXU1, VGG2, VGGN, VSD2, VX2, VX4
	16561-ZL0-V30	1	-	1	1	-----	VEE9, VENN, VGS5, VGS9, VPM4, VPM8, VPM9, VS17, VS19, VSD1
	16561-ZL0-U30	1	-	1	-	-----	VSD, VSD7, VSD9, VXU, VXU1
8	16562-ZE1-020	SPRING, THROTTLE RETURN	1	1	1	1	-----	HX2, HXU, LX2, LX4, LXAU, PXU, QG2, QH26, QH4, QHQ4, QMP4, QX2, QX26, QX4, QX7, QX9, QXAG, QXB2, QXC9, QXD4, QXD9, QXE2, QXE4, QXE5, QXE6, QXU, RDG4, RH2, RHG4, RHQ4, RMG2, RX4, RXU, SAR, SHQ2, SHQ4, SM12, SM14, SM24, SMC2, SMC4, SMCR, SWG4, SX4, SX7, SX9, SXE4, SXE5, SXU, SXW9, TX2, TX4, TXD1, TXDU, TXU, TXU1, VEE9, VGG2, VGGN, VGS5, VGS9, VPM4, VPM8, VPM9, VS17, VS19, VSD, VSD1, VSD2, VSD7, VSD9, VX2, VX4, VXU, VXU1
	16562-ZL0-V30	-	-	-	1	-----	VENN
9	16570-ZB2-000	CONTROL ASSY.	1	-	1	1	-----	VEE9, VGS5, VGS9, VPM4, VPM8, VPM9, VS17, VS19, VSD, VSD1, VSD2, VSD7, VSD9, VXU, VXU1
10	16571-ZH8-020	LEVER, CONTROL	1	1	-	-	-----	HX2, HXU, LX2, LX4, LXAU, PXU, QG2, QH26, QH4, QHQ4, QMP4, QX2, QX26, QX4, QX7, QX9, QXB2, QXC9, QXD4, QXD9, QXE2, QXE4, QXE5, QXE6, QXU, RH2, RHG4, RHQ4, RMG2, RX4, RXU, SAR, SHQ2, SHQ4, SM12, SMC2, SMC4, SMCR, SWG4, SX4, SX7, SX9, SXE4, SXE5, SXU, TX2, TX4, TXD1, TXDU, TXU, TXU1, VGG2, VGGN, VX2, VX4
	16571-Z4M-000	-	-	1	1	-----	HX2, LX4, LXAU, PXU, QG2, QH26, QHQ4, QMP4, QX2, QX4, QX9, QXAG, QXB2, QXC9, QXD4, QXD9, QXE2, QXE4, QXE5, RDG4, RH2, RHG4, RHQ4, RMG2, RX4, RXU, SAR, SHQ4, SM12, SM14, SM24, SMC4, SMCR, SWG4, SX4, SX9, SXE5, SXU, SXW9, TX2, TXD1, TXDU, VGGN
11	16574-ZE1-000	SPRING, LEVER	1	1	1	1	-----	HX2, HXU, LX2, LX4, LXAU, PXU, QG2, QH26, QH4, QHQ4, QMP4, QX2, QX26, QX4, QX7, QX9, QXAG, QXB2, QXC9, QXD4, QXD9, QXE2, QXE4, QXE5, QXE6, QXU, RDG4, RH2, RHG4, RHQ4, RMG2, RX4, RXU, SAR, SHQ2, SHQ4, SM12, SM14, SM24, SMC2, SMC4, SMCR, SWG4, SX4, SX7, SX9, SXE4, SXE5, SXU, SXW9, TX2, TX4, TXD1, TXDU, TXU, TXU1, VGG2, VGGN, VX2, VX4
12	16575-ZH8-000	WASHER, CONTROL LEVER	1	1	1	1	-----	HX2, HXU, LX2, LX4, LXAU, PXU, QG2, QH26, QH4, QHQ4, QMP4, QX2, QX26, QX4, QX7, QX9, QXAG, QXB2, QXC9, QXD4, QXD9, QXE2, QXE4, QXE5, QXE6, QXU, RDG4, RH2, RHG4, RHQ4, RMG2, RX4, RXU, SAR, SHQ2, SHQ4, SM12, SM14, SM24, SMC2, SMC4, SMCR, SWG4, SX4, SX7, SX9, SXE4, SXE5, SXU, SXW9, TX2, TX4, TXD1, TXDU, TXU, TXU1, VGG2, VGGN, VX2, VX4
13	16576-891-000	HOLDER, CABLE	1	1	1	1	-----	HX2, HXU, LX2, LX4, LXAU, QG2, QH26, QH4, QHQ4, QMP4, QX2, QX26, QX4, QX7, QX9, QXAG, QXB2, QXC9, QXD4, QXD9, QXE2, QXE4, QXE5, QXE6, QXU, RDG4, RH2, RHG4, RHQ4, RMG2, RX4, RXU, SAR, SHQ2, SHQ4, SM12, SM14, SM24, SMC2, SMC4, SMCR, SWG4, SX4, SX7, SX9, SXE4, SXE5, SXU, SXW9
14	16578-ZE1-000	SPACER, CONTROL LEVER	1	1	1	1	-----	HX2, HXU, LX2, LX4, LXAU, PXU, QG2, QH26, QH4, QHQ4, QMP4, QX2, QX26, QX4, QX7, QX9, QXAG, QXB2, QXC9, QXD4, QXD9, QXE2, QXE4, QXE5, QXE6, QXU, RDG4, RH2, RHG4, RHQ4, RMG2, RX4, RXU, SAR, SHQ2, SHQ4, SM12, SM14, SM24, SMC2, SMC4, SMCR, SWG4, SX4, SX7, SX9, SXE4, SXE5, SXU, SXW9, TX2, TX4, TXD1, TXDU, TXU, TXU1, VGG2, VGGN, VX2, VX4
15	16580-ZH8-813	BASE COMP., CONTROL(REMOTE) ..	1	1	-	-	-----	HX2, HXU, LX2, LX4, LXAU, QG2, QH26, QHQ4, QMP4, QX2, QX26, QX4, QX7, QX9, QXB2, QXD4, QXD9, QXE2, QXE4, QXE5, QXE6, QXU, RH2, RHG4, RHQ4, RMG2, RX4, RXU, SAR, SHQ2, SHQ4, SM12, SMC2, SMC4, SMCR, SWG4, SX4, SX7, SX9, SXE4, SXE5, SXU
	16580-ZH8-030	BASE COMP., CONTROL	1	-	-	-	-----	PXU, TX2, TX4, TXD1, TXDU, TXU, TXU1, VGG2, VGGN, VX2, VX4
	16580-ZH8-853	BASE COMP., CONTROL(CYCLONE) ..	1	-	-	-	-----	QH4, QXC9
		(###)	1	-	-	-	-----	



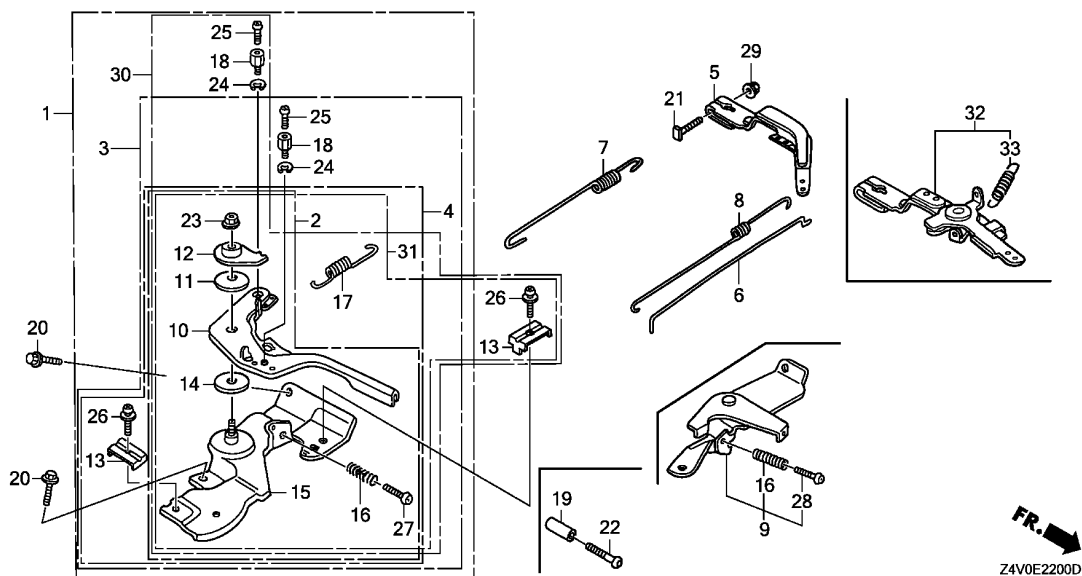

Ref. No.	Part No.	Description	Reqd. QTY				Serial No.	Parts catalogue code
			GX 200 UT	GX 200 RT	GX 200 UT2	GX 200 RT2		
15)	16580-Z4M-810	BASE COMP., CONTROL	-	-	1	1	-----	HX2,LX4,LXAU,QG2,QH26,QHQ4,QMP4,QX2,QX4,QX9,QXAG,QXB2,QXD4 QXD9,QXE2,QXE4,QXE5,RDG4,RH2,RHG4,RHQ4,RMG2,RX4,RXU,SAR,SHQ4 SM12,SM14,SM24,SMC4,SMCR,SWG4,SX4,SX9,SXE5,SXU
	16580-Z4M-000	-	-	1	1	-----	PXU, TX2, TXD1, TXDU, VGGN
	16580-Z4M-850	-	-	1	-	-----	QXC9, SXW9
16	16584-883-300	SPRING, CONTROL ADJUSTING ...	1	1	1	1	-----	HX2,HXU,LX2,LX4,LXAU,PXU,QG2,QH26,QH4,QHQ4,QMP4,QX2,QX26,QX4 QX7,QX9,QXAG,QXB2,QXC9,QXD4,QXD9,QXE2,QXE4,QXE5,QXE6,QXU,RDG4 RH2,RHG4,RHQ4,RMG2,RX4,RXU,SAR,SHQ2,SHQ4,SM12,SM14,SM24,SMC2 SMC4,SMCR,SWG4,SX4,SX7,SX9,SXE4,SXE5,SXU,SXW9, TX2, TX4, TXD1 TXDU, TXU, TXU1, VEE9, VGG2, VGGN, VGS5, VGS9, VPM4, VPM8, VPM9, VS17 VS19, VSD, VSD1, VSD2, VSD7, VSD9, VX2, VX4, VXU, VXU1
17	16592-ZE1-810	SPRING, CABLE RETURN	1	1	1	1	-----	HX2,HXU,LX2,LX4,LXAU,QG2,QH26,QH4,QHQ4,QMP4,QX2,QX26,QX4,QX7 QX9,QXAG,QXB2,QXC9,QXD4,QXD9,QXE2,QXE4,QXE5,QXE6,QXU,RDG4,RH2 RHG4,RHQ4,RMG2,RX4,RXU,SAR,SHQ2,SHQ4,SM12,SM14,SM24,SMC2,SMC4 SMCR,SWG4,SX4,SX7,SX9,SXE4,SXE5,SXU,SXW9
18	16594-883-010	HOLDER, WIRE	1	-	-	-	-----	QMP4, QXB2, QXC9
			2	-	-	-	-----	SM12
			-	2	-	-	-----	SAR
			-	1	-	1	-----	SWG4
			-	-	1	-	-----	QMP4, QXB2, QXC9, SXW9
			-	-	2	-	-----	SAR, SM12, SM14, SM24
19	16599-ZG1-M10	COLLAR, STOPPER	(1)	(1)	(1)	(1)	-----	LX4, QHQ4, QMP4, QX4, QX7, QX9, QXD4, QXD9, QXE4, QXE5, RDG4, RHG4, RHQ4 RX4, SHQ2, SHQ4, SM24, SMC2, SMC4, SMCR, SWG4, SX4, SX7, SX9, SXE4, SXE5 TX4, VEE9, VGS5, VGS9, VPM4, VPM8, VPM9, VS17, VS19, VSD, VSD1, VSD7, VSD9 VX4

Ref. No.	Part No.	Description	Reqd. QTY				Serial No.	Parts catalogue code
			GX 200 UT	GX 200 RT	GX 200 UT2	GX 200 RT2		
20	90013-883-000	BOLT, FLANGE, 6X12(CT200) ...	2	2	2	2	HX2, HXU, LX2, LX4, LXAU, PXU, QG2, QH26, QH4, QHQ4, QMP4, QX2, QX26, QX4, QX7, QX9, QXAG, QXB2, QXC9, QXD4, QXD9, QXE2, QXE4, QXE5, QXE6, QXU, RDG4, RH2, RHG4, RHQ4, RMG2, RX4, RXU, SAR, SHQ2, SHQ4, SM12, SM14, SM24, SMC2, SMC4, SMCR, SWG4, SX4, SX7, SX9, SXE4, SXE5, SXU, SXW9, TX2, TX4, TXD1, TXDU, TXU, TXU1, VEE9, VGG2, VGGN, VGS5, VGS9, VPM4, VPM8, VPM9, VS17, VSD9, VSD1, VSD2, VSD7, VSD9, VX2, VX4, VXU, VXU1	
21	90015-ZE5-010	BOLT, GOVERNOR ARM	1	1	1	1		
22	90016-ZG9-N30	SCREW, RECESSED, 5X25	(1)	(1)	(1)	(1)	LX4, QHQ4, QMP4, QX4, QX7, QX9, QXD4, QXD9, QXE4, QXE5, RDG4, RHG4, RHQ4, RX4, SHQ2, SHQ4, SM24, SMC2, SMC4, SMCR, SWG4, SX4, SX7, SX9, SXE4, SXE5, TX4, VEE9, VGS5, VGS9, VPM4, VPM8, VPM9, VS17, VS19, VSD, VSD1, VSD7, VSD9, VX4	
23	90114-SA0-000	NUT, SELF-LOCK, 6MM	1	1	1	1	HX2, HXU, LX2, LX4, LXAU, PXU, QG2, QH26, QH4, QHQ4, QMP4, QX2, QX26, QX4, QX7, QX9, QXAG, QXB2, QXC9, QXD4, QXD9, QXE2, QXE4, QXE5, QXE6, QXU, RDG4, RH2, RHG4, RHQ4, RMG2, RX4, RXU, SAR, SHQ2, SHQ4, SM12, SM14, SM24, SMC2, SMC4, SMCR, SWG4, SX4, SX7, SX9, SXE4, SXE5, SXU, SXW9, TX2, TX4, TXD1, TXDU, TXU, TXU1, VGG2, VGGN, VX2, VX4	
24	90605-230-000	CIRCLIP, 5MM	1	-	-	-	QMP4, QXB2, QXC9	
			2	-	-	-	SM12	
			-	2	-	-	SAR	
			-	1	1	-	SWG4	
			-	-	1	-	QMP4, QXB2, QXC9, SXW9	
			-	-	2	-	SAR, SM12, SM14, SM24	
25	93500-04006-0H	SCREW, PAN, 4X6	1	-	-	-	QMP4, QXB2, QXC9	
			2	-	-	-	SM12	
			-	2	-	-	SAR	
			-	1	1	-	SWG4	
			-	-	1	-	QMP4, QXB2, QXC9, SXW9	
			-	-	2	-	SAR, SM12, SM14, SM24	
26	93500-05016-0A	SCREW, PAN, 5X16	1	1	1	1	HX2, HXU, LX2, LX4, LXAU, QG2, QH26, QH4, QHQ4, QMP4, QX2, QX26, QX4, QX7, QX9, QXAG, QXB2, QXC9, QXD4, QXD9, QXE2, QXE4, QXE5, QXE6, QXU, RDG4, RH2, RHG4, RHQ4, RMG2, RX4, RXU, SAR, SHQ2, SHQ4, SM12, SM14, SM24, SMC2, SMC4, SMCR, SWG4, SX4, SX7, SX9, SXE4, SXE5, SXU, SXW9	
27	93500-05025-0H	SCREW, PAN, 5X25	1	1	-	-	HX2, HXU, LX2, LX4, LXAU, QG2, QH26, QH4, QHQ4, QMP4, QX2, QX26, QX4, QX7, QX9, QXB2, QXC9, QXD4, QXD9, QXE2, QXE4, QXE5, QXE6, QXU, RH2, RHG4, RHQ4, RMG2, RX4, RXU, SAR, SHQ2, SHQ4, SM12, SMC2, SMC4, SMCR, SWG4, SX4, SX7, SX9, SXE4, SXE5, SXU	
	93500-05025-0A	1	-	-	-	PXU, TX2, TX4, TXD1, TXDU, TXU, TXU1, VGG2, VGGN, VX2, VX4	
	93500-05025-0H	-	-	1	1	HX2, LX4, LXAU, PXU, QG2, QH26, QH4, QHQ4, QMP4, QX2, QX4, QX9, QXAG, QXB2, QXC9, QXD4, QXD9, QXE2, QXE4, QXE5, RDG4, RH2, RHG4, RHQ4, RMG2, RX4, RXU, SAR, SHQ2, SHQ4, SM12, SM14, SM24, SMC4, SMCR, SWG4, SX4, SX9, SXE5, SXU, SXW9, TX2, TXD1, TXDU, VGGN	
28	93500-05035-0A	SCREW, PAN, 5X35	1	-	1	1	VEE9, VGS5, VGS9, VPM4, VPM8, VPM9, VS17, VS19, VSD, VSD1, VSD2, VSD7, VSD9, VXU, VXU1	
29	94050-06000	NUT, FLANGE, 6MM	1	1	1	1		
30	16500-ZH8-893	CONTROL ASSY. (REMOTE INTL-S)	1	1	-	-	QMP4, SWG4	
	16500-Z4M-406	CONTROL ASSY. (REMOTE INTL-S) (COO) (FOR U.S.A.)	-	-	1	1	QMP4, SWG4	
31	16500-ZH8-P40	CONTROL ASSY. (CYCLONE-REMOTE)	1	-	-	-	QH4	
32	16550-ZLO-V30	ARM COMP., GOVERNOR	-	-	-	1	VENN	
33	16559-ZLO-V30	SPRING, GOVERNOR ARM RETURN	-	-	-	1	VENN	



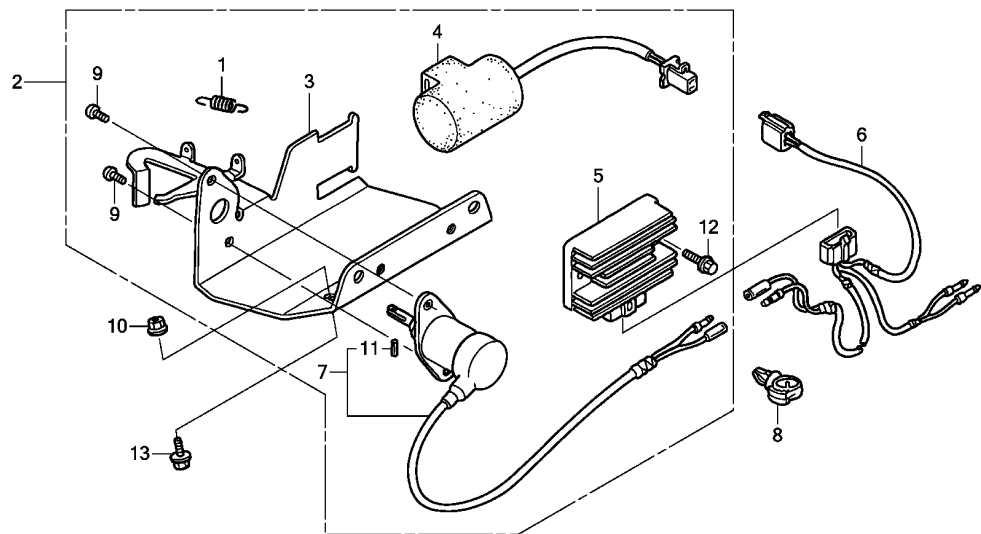

Z4V0E2220

Ref. L.O.N. (Relative ref. Number) F.R.T.
No. Description

Ref. No.	Part No.	Description	Reqd. QTY				Serial No.	Parts catalogue code
			GX 200 UT	GX 200 RT	GX 200 UT2	GX 200 RT2		
1	16268-893-000	SPRING, CHOKE RETURN	-	-	-	1	----- VENN	
2	16270-ZLO-V30	THROTTLE ASSY., AUTO	-	-	-	1	----- VENN	
3	16273-ZLO-V30	LEVER, SOLENOID THROTTLE	-	-	-	1	----- VENN	
4	31700-KAE-871	CONDENSER UNIT	-	-	-	1	----- VENN	
5	31750-ZLO-V31	RECTIFIER ASSY., REGULATOR ..	-	-	-	1	----- VENN	
6	32110-ZLO-V30	SUB HARNESS ASSY.	-	-	-	1	----- VENN	
7	36330-ZLO-V31	SOLENOID ASSY., AUTO THROTTLE	-	-	-	1	----- VENN	
8	90683-SAO-003	CLIP, WIRE HARNESS, 25MM	-	-	-	2	----- VENN	
9	93500-05008-0A	SCREW, PAN, 5X8	-	-	-	2	----- VENN	
10	94050-06000	NUT, FLANGE, 6MM	-	-	-	1	----- VENN	
11	94305-20062	PIN, SPRING, 2X6	-	-	-	1	----- VENN	
12	95701-06016-00	BOLT, FLANGE, 6X16	-	-	-	2	----- VENN	
13	95701-06025-00	BOLT, FLANGE, 6X25	-	-	-	2	----- VENN	

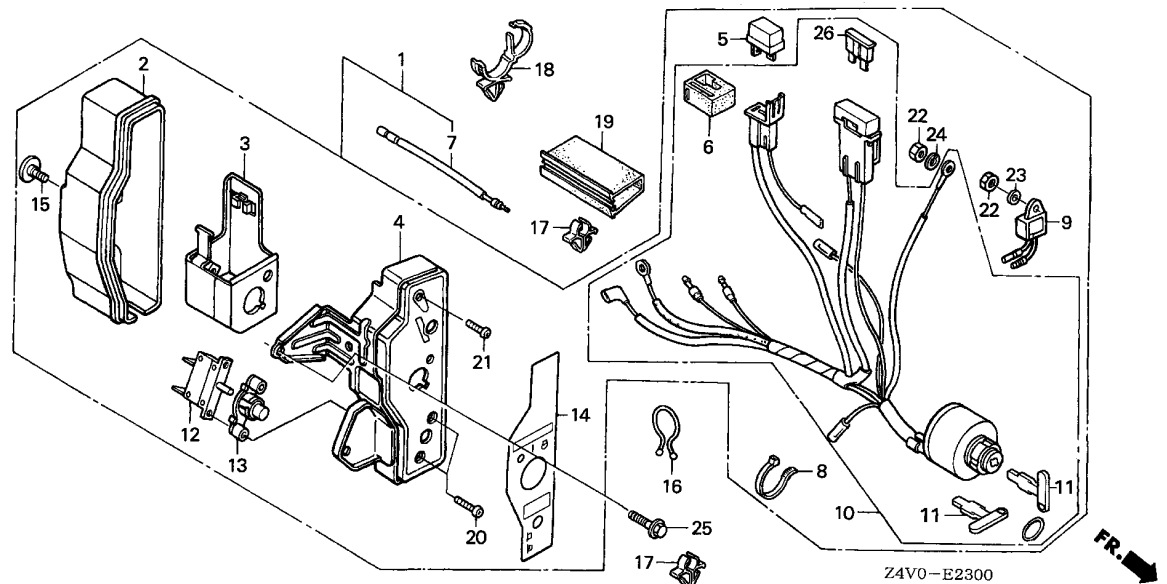

Ref. No.	L.O.N.	(Relative ref. Number) Description	F.R.T.
----------	--------	------------------------------------	--------

Ref. No.	Part No.	Description	Reqd. QTY				Serial No.	Parts catalogue code
			GX 200 UT	GX 200 RT	GX 200 UT2	GX 200 RT2		
1	31610-Z4S-821ZA	BOX ASSY., CONTROL (EXP-ALERT/10A)						
		R280.....POWER RED	1	-	1	-	-----	QH4,QXE5,SXE5
	31610-Z4T-842ZA	BOX ASSY., CONTROL(EXP-ALERT)						
		NH1.....BLACK	1	-	1	-	-----	QXE2,QXE4,QXE6
	31610-Z4T-842ZB	*R280*.....POWER RED	1	-	1	-	-----	QXE2,QXE4,QXE6,SXE4,TXD1
	31610-Z4T-841ZA	*NH1*.....BLACK	1	-	-	-	1338460	TXU1
	31610-Z4T-841ZB	*R280*.....POWER RED	1	-	-	-	1338460	TXU1
	31610-Z4T-842ZA	*NH1*.....BLACK	1	-	-	-	1338461	TXU1
	31610-Z4T-842ZB	*R280*.....POWER RED	1	-	-	-	1338461	TXU1
2	31612-ZE2-003	CASE, CONTROL	1	-	1	-	-----	QH4,QXE2,QXE4,QXE5,QXE6,SXE4,SXE5,TXD1,TXU1
3	31614-ZE2-003	BRACKET, CASE MOUNTING	1	-	1	-	-----	QH4,QXE2,QXE4,QXE5,QXE6,SXE4,SXE5,TXD1,TXU1
4	31615-ZE1-003ZG	PANEL COMP., CONTROL						
		R280.....POWER RED	1	-	1	-	-----	QH4,QXE2,QXE4,QXE5,QXE6,SXE4,SXE5,TXD1,TXU1
	31615-ZE1-003ZA	*NH1*.....BLACK	1	-	1	-	-----	QXE2,QXE4,QXE6,TXU1
5	31700-124-008	RECTIFIER ASSY., SILICON (SHINDENGEN)	1	-	1	-	-----	QXE2,QXE4,QXE6,SXE4,TXD1,TXU1
6	32127-738-700	SUSPENSION, COUPLER	1	-	1	-	-----	QXE2,QXE4,QXE6,SXE4,TXD1,TXU1
7	32197-ZE1-003	HARNES, SUB WIRE	1	-	1	-	-----	QH4,QXE2,QXE4,QXE5,QXE6,SXE4,SXE5,TXD1,TXU1
8	32902-892-003	BAND	1	-	1	-	-----	QH4,QXE2,QXE4,QXE5,QXE6,SXE4,SXE5,TXD1,TXU1
9	34150-ZH7-013	ALERT UNIT, OIL	1	-	1	-	-----	QH4,QXE2,QXE4,QXE5,QXE6,SXE4,SXE5,TXD1
	34150-ZH7-003	1	-	-	-	1338460	TXU1
	34150-ZH7-013	1	-	-	-	1338461	TXU1
10	35100-ZH8-R90	SWITCH ASSY., COMBINATION (10A CHG/RCM)	1	-	1	-	-----	QH4,QXE5,SXE5
	35100-ZE1-812	SWITCH ASSY., COMBINATION	1	-	1	-	-----	QXE2,QXE4,QXE6,SXE4,TXD1,TXU1
11	35111-880-013	KEY COMP.	2	-	2	-	-----	QH4,QXE2,QXE4,QXE5,QXE6,SXE4,SXE5,TXD1,TXU1



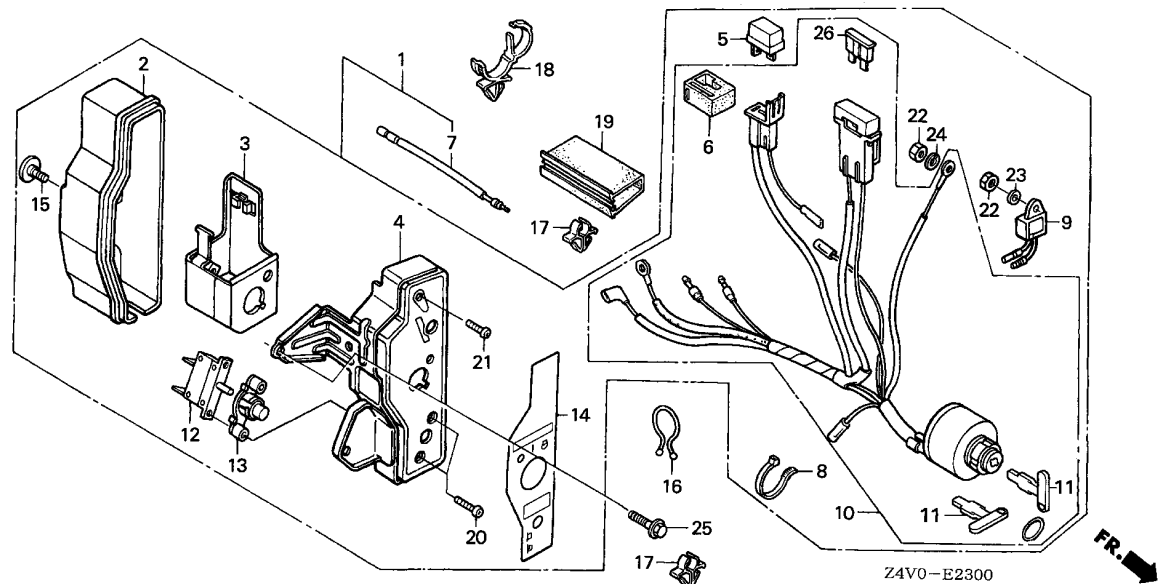

Ref. No.	Part No.	Description	Reqd. QTY				Serial No.	Parts catalogue code
			GX 200 UT	GX 200 RT	GX 200 UT2	GX 200 RT2		
12	38240-VA3-900	PROTECTOR, CIRCUIT(1.0A)	1	-	1	-	-----	QXE2,QXE4,QXE6,SXE4,TXD1,TXU1
13	38250-ZA8-701	LENS ASSY., PROTECTOR	1	-	1	-	-----	QXE2,QXE4,QXE6,SXE4,TXD1,TXU1
14	87529-Z4S-820	MARK, CONTROL BOX(EXP)	1	-	1	-	-----	QH4,QXE5,SXE5
	87529-Z4T-840	MARK, CONTROL BOX(EXTERNAL)	1	-	1	-	-----	QXE2,QXE4,QXE6,SXE4,TXD1,TXU1
15	90380-MA6-010	SCREW, SPECIAL, 6X12	1	-	1	-	-----	QH4,QXE2,QXE4,QXE5,QXE6,SXE4,SXE5,TXD1,TXU1
16	90630-751-000	CLIP, PURSE LOCK	1	-	1	-	-----	QH4,QXE2,QXE4,QXE5,QXE6,SXE4,SXE5,TXD1,TXU1
17	90682-ZE1-000	CLIP, CORD	2	-	2	-	-----	QH4,QXE2,QXE4,QXE5,QXE6,SXE4,SXE5,TXD1,TXU1
18	90690-SAO-003	STRAP, WIRE HARNESS, 25MM (BLACK)	1	-	1	-	-----	QH4,QXE2,QXE4,QXE5,QXE6,SXE4,SXE5,TXD1,TXU1
19	91406-ZE2-003	TUBE, FASTENER, 30MM	1	-	1	-	-----	QH4,QXE2,QXE4,QXE5,QXE6,SXE4,SXE5,TXD1,TXU1
20	93500-03012-0H	SCREW, PAN, 3X12	2	-	2	-	-----	QXE2,QXE4,QXE6,SXE4,TXD1,TXU1
21	93500-04012-0H	SCREW, PAN, 4X12	1	-	1	-	-----	QH4,QXE2,QXE4,QXE5,QXE6,SXE4,SXE5,TXD1,TXU1
22	94001-04390-0S	NUT, HEX., 4MM	2	-	2	-	-----	QH4,QXE2,QXE4,QXE5,QXE6,SXE4,SXE5,TXD1,TXU1
23	94101-04800	WASHER, PLAIN, 4MM	1	-	1	-	-----	QH4,QXE2,QXE4,QXE5,QXE6,SXE4,SXE5,TXD1,TXU1
24	94111-04800	WASHER, SPRING, 4MM	1	-	1	-	-----	QH4,QXE2,QXE4,QXE5,QXE6,SXE4,SXE5,TXD1,TXU1
25	95701-06010-00	BOLT, FLANGE, 6X10	1	-	1	-	-----	QH4,QXE2,QXE4,QXE5,QXE6,SXE4,SXE5,TXD1,TXU1
26	98200-31500	FUSE, BLADE(15A)	1	-	1	-	-----	QH4,QXE5,SXE5
	98200-30500	FUSE, BLADE(5A)	1	-	1	-	-----	QXE2,QXE4,QXE6,SXE4,TXD1,TXU1

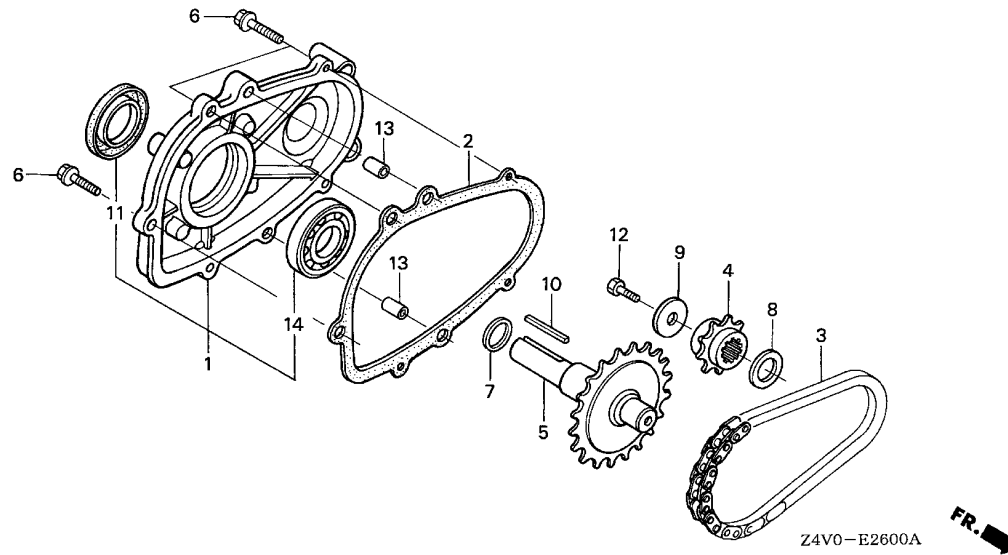

Ref. No.	L.O.N. (Relative ref. Number)	Description	F.R.T.
----------	-------------------------------	-------------	--------

Ref. No.	Part No.	Description	Reqd. QTY				Serial No.	Parts catalogue code
			GX 200	GX 200	GX 200	GX 200		
			UT	RT	UT2	RT2		
1	11500-ZE1-611	COVER ASSY., CHAIN CASE	1	-	1	-	-----	LX2,LX4,LXAU
2	11521-ZH8-800	PACKING, CHAIN CASE COVER	1	-	1	-	-----	LX2,LX4,LXAU
3	14411-ZE1-611	CHAIN, P.T.O. DRIVE (DID317FM2-34LE)	1	-	1	-	-----	LX2,LX4,LXAU
4	23110-ZE1-610	SPROCKET, DRIVE(13T)	1	-	1	-	-----	LX2,LX4,LXAU
5	23710-ZE1-613	SHAFT, P.T.O.(26T)	1	-	1	-	-----	LX2,LX4,LXAU
6	90015-883-000	BOLT, FLANGE, 6X28(CT200)	5	-	5	-	-----	LX2,LX4,LXAU
7	90456-ZE1-000	SPRING, THRUST	1	-	1	-	-----	LX2,LX4,LXAU
8	90470-ZE1-000	SPACER, 20MM	1	-	1	-	-----	LX2,LX4,LXAU
9	90471-ZE1-610	WASHER, 8MM	1	-	1	-	-----	LX2,LX4,LXAU
10	90741-883-810	KEY, 5X5X33(YELLOW)	1	-	1	-	-----	LX2,LX4,LXAU
11	91201-Z0T-801	OIL SEAL, 25X41X6	1	-	1	-	-----	LX2,LX4,LXAU
12	92101-08025-0A	BOLT, HEX., 8X25	1	-	1	-	-----	LX2,LX4,LXAU
13	94301-08140	DOWEL PIN, 8X14	2	-	2	-	-----	LX2,LX4,LXAU
14	96100-62050-00	BEARING, RADIAL BALL, 6205	1	-	1	-	-----	LX2,LX4,LXAU

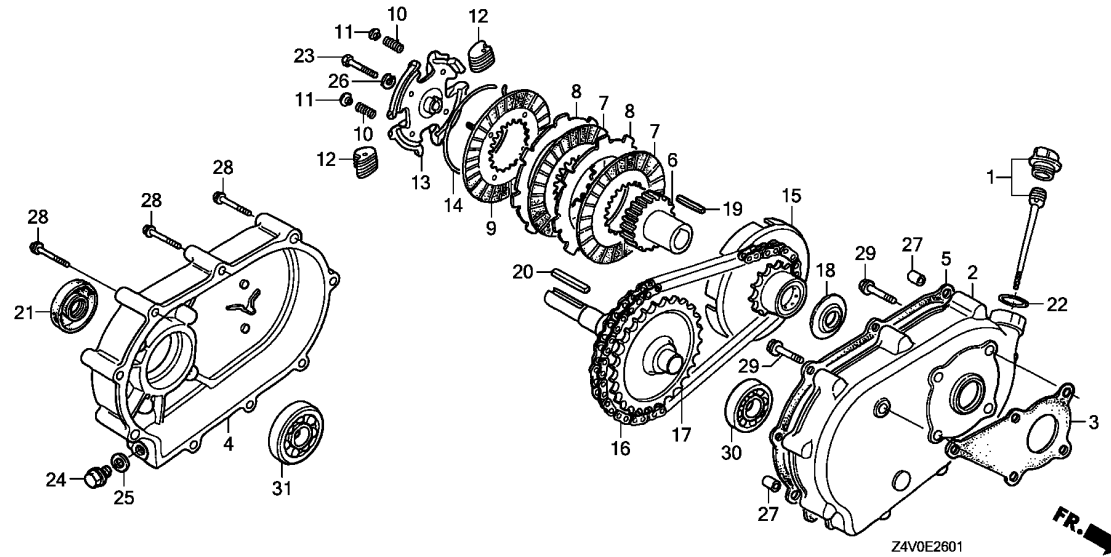

Ref. No.	L.O.N. (Relative ref. Number)	Description	F.R.T.
----------	-------------------------------	-------------	--------

Ref. No.	Part No.	Description	Reqd. QTY				Serial No.	Parts catalogue code
			GX 200 UT	GX 200 RT	GX 200 UT2	GX 200 RT2		
1	15600-ZH7-000	CAP ASSY., OIL FILLER	1	1	1	1	RDG4, RH2, RHG4, RHQ4, RMG2, RX4, RXU	
2	21510-883-621	CASE, REDUCTION	1	1	1	1	RDG4, RH2, RHG4, RHQ4, RMG2, RX4, RXU	
3	21591-ZH8-620	PACKING, REDUCTION CASE	1	1	1	1	RDG4, RH2, RHG4, RHQ4, RMG2, RX4, RXU	
4	21610-822-611	COVER, REDUCTION	1	1	1	1	RDG4, RH2, RHG4, RHQ4, RMG2, RX4, RXU	
5	21691-ZH8-800	PACKING, REDUCTION COVER	1	1	1	1	RDG4, RH2, RHG4, RHQ4, RMG2, RX4, RXU	
6	22121-883-620	CENTER, CLUTCH	1	1	1	1	RDG4, RH2, RHG4, RHQ4, RMG2, RX4, RXU	
7	22201-822-610	DISK, CLUTCH FRICTION	2	2	2	2	RDG4, RH2, RHG4, RHQ4, RMG2, RX4, RXU	
8	22311-822-610	PLATE, CLUTCH	2	2	2	2	RDG4, RH2, RHG4, RHQ4, RMG2, RX4, RXU	
9	22350-822-610	PLATE COMP., CLUTCH PRESSURE	1	1	1	1	RDG4, RH2, RHG4, RHQ4, RMG2, RX4, RXU	
10	22411-822-611	SPRING, CLUTCH FREE	4	4	4	4	RDG4, RH2, RHG4, RHQ4, RMG2, RX4, RXU	
11	22421-822-610	HOLDER, CLUTCH SPRING	4	4	4	4	RDG4, RH2, RHG4, RHQ4, RMG2, RX4, RXU	
12	22521-822-610	WEIGHT, CLUTCH	48	48	48	48	RDG4, RH2, RHG4, RHQ4, RMG2, RX4, RXU	
13	22531-883-620	HOLDER, CLUTCH WEIGHT	1	1	1	1	RDG4, RH2, RHG4, RHQ4, RMG2, RX4, RXU	
14	22535-822-610	CENTER, CLUTCH WEIGHT	1	1	1	1	RDG4, RH2, RHG4, RHQ4, RMG2, RX4, RXU	
15	23120-883-620	SPROCKET COMP., DRIVE	1	1	1	1	RDG4, RH2, RHG4, RHQ4, RMG2, RX4, RXU	
16	23161-822-611	CHAIN, DRIVE(RK428SH-36LE)	1	1	1	1	RDG4, RH2, RHG4, RHQ4, RMG2, RX4, RXU	
17	23711-822-610	SHAFT COMP., P.T.O.(28T)	1	1	1	1	RDG4, RH2, RHG4, RHQ4, RMG2, RX4, RXU	
18	90403-883-620	WASHER, THRUST, 20MM	1	1	1	1	RDG4, RH2, RHG4, RHQ4, RMG2, RX4, RXU	
19	90741-883-621	KEY, 5MM	1	1	1	1	RDG4, RH2, RHG4, RHQ4, RMG2, RX4, RXU	
20	90741-889-810	KEY, 7X7X33(YELLOW)(O.S.)	1	1	1	1	RDG4, RH2, RHG4, RHQ4, RMG2, RX4, RXU	
21	91202-Z2F-801	OIL SEAL, 30X50X7	1	1	1	1	RDG4, RH2, RHG4, RHQ4, RMG2, RX4, RXU	
22	91301-805-000	O-RING, 26X2.7	1	1	1	1	RDG4, RH2, RHG4, RHQ4, RMG2, RX4, RXU	
23	92101-08035-0A	BOLT, HEX., 8X35	1	1	1	1	RDG4, RH2, RHG4, RHQ4, RMG2, RX4, RXU	
24	92800-12000	BOLT, DRAIN PLUG, 12MM	1	1	1	1	RDG4, RH2, RHG4, RHQ4, RMG2, RX4, RXU	
25	94109-12000	WASHER, DRAIN PLUG, 12MM	1	1	1	1	RDG4, RH2, RHG4, RHQ4, RMG2, RX4, RXU	

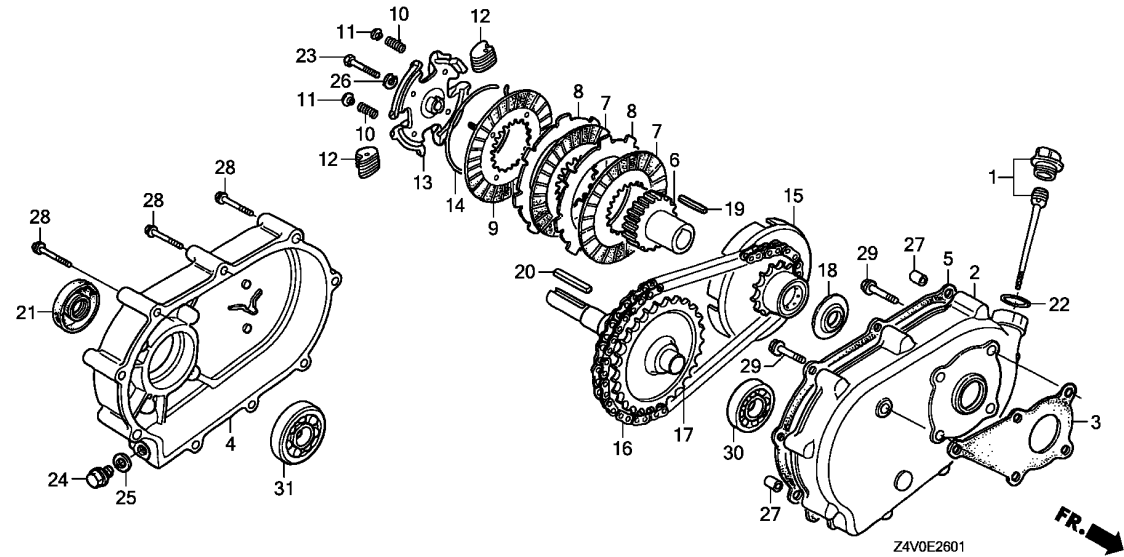

Ref. No.	Part No.	Description	Reqd. QTY				Serial No.	Parts catalogue code
			GX 200 UT	GX 200 RT	GX 200 UT2	GX 200 RT2		
26	94111-08800	WASHER, SPRING, 8MM	1	1	1	1	----- RDG4, RH2, RHG4, RHQ4, RMG2, RX4, RXU	
27	94301-08100	DOWEL PIN, 8X10	2	2	2	2	----- RDG4, RH2, RHG4, RHQ4, RMG2, RX4, RXU	
28	95701-06055-00	BOLT, FLANGE, 6X55	9	9	9	9	----- RDG4, RH2, RHG4, RHQ4, RMG2, RX4, RXU	
29	95701-08022-00	BOLT, FLANGE, 8X22	5	5	5	5	----- RDG4, RH2, RHG4, RHQ4, RMG2, RX4, RXU	
30	96100-62050-00	BEARING, RADIAL BALL, 6205 ..	1	1	1	1	----- RDG4, RH2, RHG4, RHQ4, RMG2, RX4, RXU	
31	96100-62060-00	BEARING, RADIAL BALL, 6206 ..	1	1	1	1	----- RDG4, RH2, RHG4, RHQ4, RMG2, RX4, RXU	



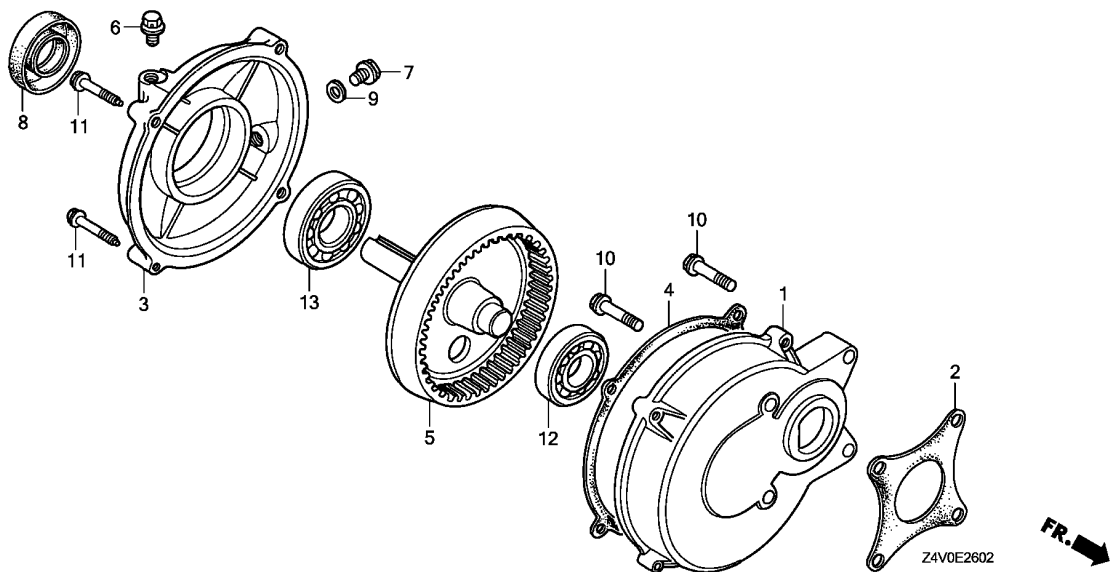

Ref. L.O.N. (Relative ref. Number) F.R.T.
 No. Description

Ref. No.	Part No.	Description	Reqd. QTY				Serial No.	Parts catalogue code
			GX 200 UT	GX 200 RT	GX 200 UT2	GX 200 RT2		
1	21521-883-741	CASE, REDUCTION	1	-	1	-	-----	HX2,HXU
2	21591-ZH8-740	PACKING, REDUCTION CASE	1	-	1	-	-----	HX2,HXU
3	21621-883-741	COVER, REDUCTION	1	-	1	-	-----	HX2,HXU
4	21692-ZH8-800	PACKING, REDUCTION COVER	1	-	-	-	-----	HX2,HXU
	21692-ZH7-000	-	-	1	-	-----	HX2
5	23710-883-740	SHAFT, P.T.O.(86T)	1	-	1	-	-----	HX2,HXU
6	90002-883-740	BOLT, BREATHING	1	-	1	-	-----	HX2,HXU
7	90131-883-000	BOLT, DRAIN PLUG, 12X15	1	-	1	-	-----	HX2,HXU
8	91201-Z0T-801	OIL SEAL, 25X41X6	1	-	1	-	-----	HX2,HXU
9	94109-12000	WASHER, DRAIN PLUG, 12MM	1	-	1	-	-----	HX2,HXU
10	95701-08032-08	BOLT, FLANGE, 8X32	4	-	4	-	-----	HX2,HXU
11	95701-08035-00	BOLT, FLANGE, 8X35	4	-	4	-	-----	HX2,HXU
12	96100-62040-00	BEARING, RADIAL BALL, 6204 ..	1	-	1	-	-----	HX2,HXU
13	96100-63050-00	BEARING, RADIAL BALL, 6305 ..	1	-	1	-	-----	HX2,HXU

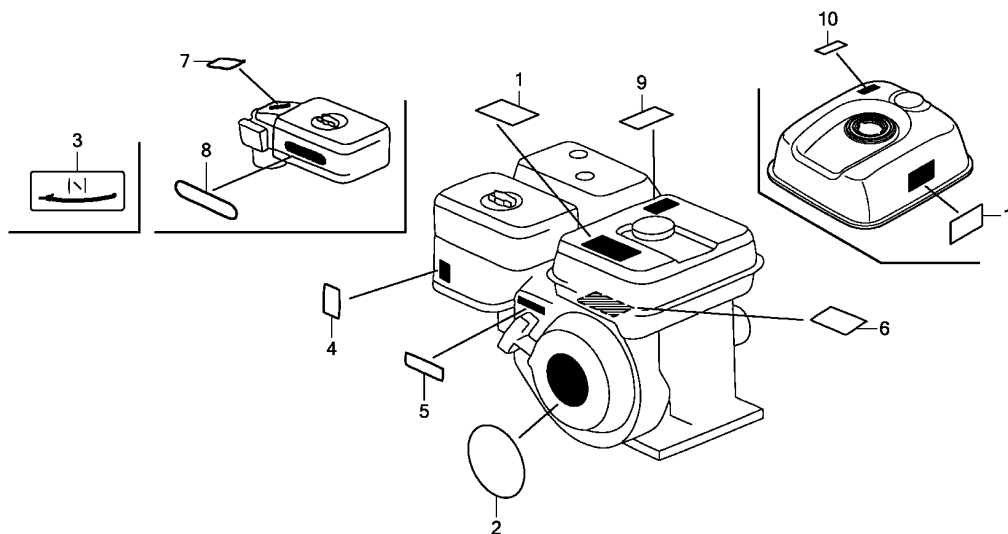

Z4V0E2800D

Ref. No. L.O.N. (Relative ref. Number) Description F.R.T.

Ref. No.	Part No.	Description	Reqd. QTY				Serial No.	Parts catalogue code
			GX 200 UT	GX 200 RT	GX 200 UT2	GX 200 RT2		
1	87516-Z4H-000	MARK, OPERATOR CAUTION (ENGLISH)(MADE IN THAI)	1	1	-	-	HX2, HXU, LX2, LX4, LXAU, PXU, QG2, QH26, QH4, QHQ4, QMP4, QX2, QX26, QX4, QX7, QX9, QXB2, QXC9, QXE2, QXE4, QXE5, QXE6, QXU, RH2, RHQ4, RX4, RXU, SAR, SHQ4, SM12, SMC4, SX4, SX7, SX9, SXE4, SXE5, SXU, TX2, TX4, TXD1, TXDU, TXU, TXU1, VGG2, VPM4, VS17, VSD, VSD1, VSD2, VSD7, VSD9, VX2, VX4, VXU, VXU1	
	87516-ZH7-810	MARK, OPERATOR CAUTION (PICTOGRAPH)(MADE IN JAPAN)	(1)	(1)	-	-	HX2, HXU, QH4, QXC9, QXE2, QXE4, QXE5, QXE6, RH2, RHQ4, RX4, RXU, SAR, SXE4, SXE5	
	87516-Z4H-810	MARK, OPERATOR CAUTION (PICTOGRAPH)(MADE IN THAI)	(1)	-	-	-	LX2, LX4, LXAU, PXU, QG2, QH26, QH4, QHQ4, QMP4, QX2, QX26, QX4, QX7, QX9, QXB2, QXU, SHQ4, SM12, SMC4, SX4, SX7, SX9, SXU, TX2, TX4, TXD1, TXDU, TXU, TXU1, VGG2, VPM4, VS17, VSD, VSD1, VSD2, VSD7, VSD9, VX2, VX4, VXU, VXU1	
	87519-Z4H-000	MARK, OPERATOR CAUTION (PICTOGRAPH)	1	-	-	-	QXD4, QXD9, SMCR	
	87516-Z4H-010	MARK, OPERATOR CAUTION (ENGLISH)(MADE IN THAI)	1	-	-	-	SHQ2, SMC2	
	87519-Z4H-000	MARK, OPERATOR CAUTION (PICTOGRAPH)	-	-	1	-	HX2, LXAU, PXU, QG2, QH26, QX2, QXAG, QXC9, QXE2, RH2, RXU, SM14, SM24, SXU, SXW9, TX2, TXD1, TXDU, VXU, VXU1	
2	87521-ZL0-030	EMBLEM(GX200)	1	1	-	-	LX4, QHQ4, QMP4, QX4, QX9, QXB2, QXD4, QXD9, QXE4, QXE5, RHQ4, RX4, SAR, SHQ4, SM12, SMC4, SMC, SX4, SX9, SXE5, VSD9	
	87521-ZL0-020	EMBLEM(6.5)	1	-	-	-	HX2, HXU, QH4, QMP4, QXC9, QXD4, QXD9, QXE2, QXE4, QXE5, QXE6, RH2, RHG4, RHQ4, RMG2, RX4, RXU, SAR, SHQ2, SMC2, SMC, SWG4, SXE4, SXE5, TXD1, TXDU, VEE9, VGGN	
	87521-Z4V-000	EMBLEM(GX200)	-	-	1	1	LX2, LX4, LXAU, PXU, QG2, QH26, QH4, QX2, QX26, QX4, QX7, QX9, QXB2, QXU, SHQ4, SM12, SMC4, SX4, SX7, SX9, SXU, TX2, TX4, TXU, TXU1, VGG2, VGS5, VGS9, VPM4, VPM8, VPM9, VS17, VS19, VSD, VSD1, VSD2, VSD7, VSD9, VX2, VX4, VXU, VXU1	



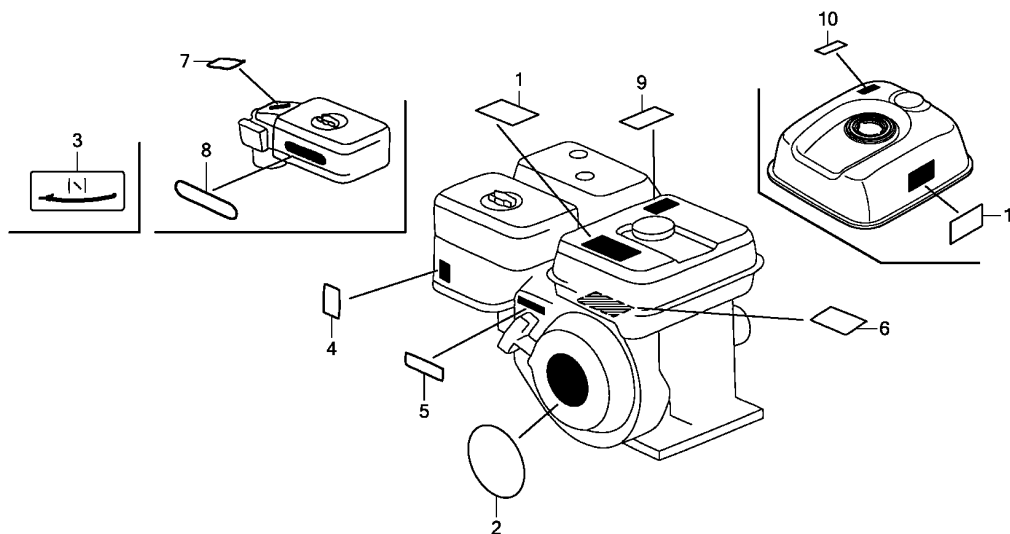

Z4V0E2800D

Ref. No.	Part No.	Description	Reqd. QTY				Serial No.	Parts catalogue code
			GX 200 UT	GX 200 RT	GX 200 UT2	GX 200 RT2		
3	87528-ZB2-630	MARK, CHOKE	1	-	-	1	-----	VPM4, VPM9
4	87528-ZH7-000	MARK, CHOKE (GRAY)	1	1	-	-	-----	HX2, HXU, LX2, LX4, LXAU, PXU, QG2, QH26, QHQ4, QMP4, QX2, QX26, QX4, QX7, QX9, QXB2, QXC9, QXD4, QXD9, QXE2, QXE4, QXE5, QXE6, QXU, RH2, RHG4, RHQ4, RMG2, RX4, RXU, SAR, SHQ2, SHQ4, SM12, SMC2, SMC4, SMCR, SX4, SX7, SX9, SXE4, SXE5, SXU, TX2, TX4, TXD1, TXDU, TXU, TXU1, VGG2, VGGN, VPM4, VPM9, VSD, VSD7, VSD9, VX2, VX4, VXU, VXU1
	87528-Z4M-000	MARK, CHOKE	-	-	1	1	-----	HX2, LX4, LXAU, PXU, QG2, QH26, QHQ4, QMP4, QX2, QX4, QX9, QXAG, QXB2, QXC9, QXD4, QXD9, QXE2, QXE4, QXE5, RDG4, RH2, RHG4, RHQ4, RMG2, RX4, RXU, SAR, SHQ4, SM12, SM14, SM24, SMC4, SMCR, SX4, SX9, SXE5, SXU, SXW9, TX2, TXD1, TXDU, VGGN, VSD9, VXU, VXU1
5	87532-ZH7-000	MARK, THROTTLE INDICATION ...	1	1	1	1	-----	HX2, HXU, LX2, LX4, LXAU, PXU, QG2, QH26, QH4, QHQ4, QMP4, QX2, QX26, QX4, QX7, QX9, QXAG, QXB2, QXC9, QXD4, QXD9, QXE2, QXE4, QXE5, QXE6, QXU, RDG4, RH2, RHG4, RHQ4, RMG2, RX4, RXU, SAR, SHQ2, SHQ4, SM12, SM14, SM24, SMC2, SMC4, SMCR, SWG4, SX4, SX7, SX9, SXE4, SXE5, SXU, SXW9, TX2, TX4, TXD1, TXDU, TXU, TXU1, VGG2, VGGN, VX2, VX4
6	87519-Z4H-000	MARK, OPERATOR CAUTION (PICTOGRAPH)	1	-	-	-	-----	VEE9
	87516-Z4H-810	MARK, OPERATOR CAUTION (PICTOGRAPH) (MADE IN THAI)	(1)	-	-	-	-----	VGGN, VPM8, VPM9, VS19
	87516-Z4H-000	MARK, OPERATOR CAUTION (ENGLISH) (MADE IN THAI)	-	1	-	-	-----	RHG4, RMG2, SWG4
	87516-ZH7-810	MARK, OPERATOR CAUTION (PICTOGRAPH) (MADE IN JAPAN)	-	(1)	-	-	-----	RHG4, RMG2, SWG4
	87519-Z4H-000	MARK, OPERATOR CAUTION (PICTOGRAPH)	-	-	-	1	-----	RDG4, RHG4, SWG4, VEE9, VPM4, VS19
	87516-Z4H-010	MARK, OPERATOR CAUTION (ENGLISH) (MADE IN THAI)	-	-	-	1	-----	RMG2, VENN, VGGN
7	87534-ZE1-841	LABEL, AIR CLEANER CAUTION ..	1	-	-	-	-----	QXC9

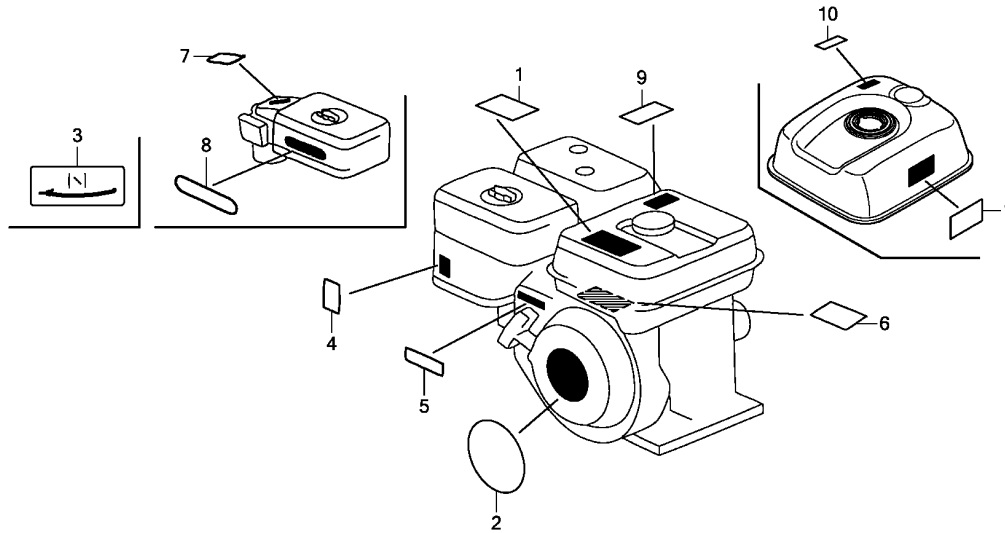

Z4V0E2800D

Ref. No.	Part No.	Description	Reqd. QTY				Serial No.	Parts catalogue code
			GX 200 UT	GX 200 RT	GX 200 UT2	GX 200 RT2		
8	87535-ZE1-841	MARK, AIR CLEANER SALES POINT	1	-	1	-	-----	QH4,QXC9,SXW9
9	87539-Z0J-000	MARK, EX. CAUTION(ENGLISH) ..	1	-	-	-	-----	SHQ2,SMC2
10	87539-Z4M-000	MARK, EX. CAUTION(ENGLISH) ..	-	-	1	-	-----	HX2,LXAU,PXU,QG2,QH26,QX2,QXAG,QXC9,QXE2,RH2,RXU,SM14,SM24,SXU SXW9,TX2,TXD1,TXDU,VXU,VXU1

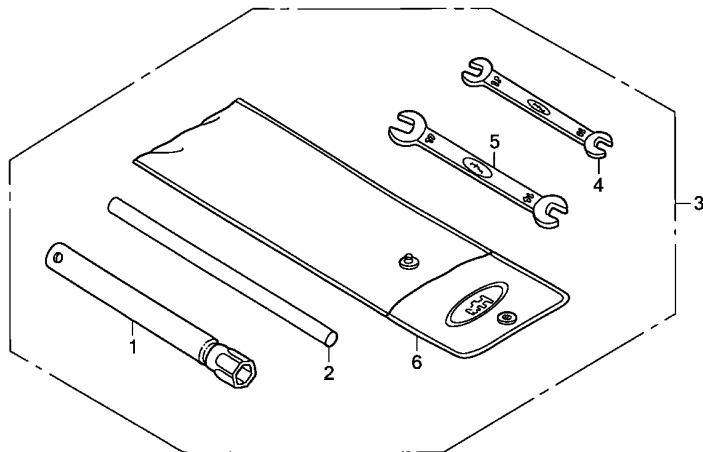

Z4V0E2900A

Ref. No.	L.O.N. (Relative ref. Number)	Description	F.R.T.
----------	-------------------------------	-------------	--------

Ref. No.	Part No.	Description	Reqd. QTY				Serial No.	Parts catalogue code
			GX 200 UT	GX 200 RT	GX 200 UT2	GX 200 RT2		
1	89216-Z0T-800	WRENCH, SPARK PLUG	1	1	1	-	----- PXU,QXC9,QXU,SAR,SM12,SM14,SM24,SMC2,SMC4,SMCR,SW9,TXD1,TXDU TXU,TXU1,VXU,VXU1	
	89218-ZE1-000	WRENCH COMP., SPARK PLUG	-	1	-	-	----- SWG4	
	89216-Z0T-800	WRENCH, SPARK PLUG	-	-	-	1	----- SWG4	
2	89219-805-000	HANDLE, BOX WRENCH	1	1	1	1	----- SAR,SM12,SM14,SM24,SWG4	
3	89000-ZE1-000	TOOL KIT	-	1	-	-	----- SWG4	
4	99001-10120	SPANNER, 10X12	-	1	-	-	----- SWG4	
	89212-KWW-601	-	-	-	1	----- SWG4	
5	99001-14170	SPANNER, 14X17	-	1	-	-	----- SWG4	
6	99008-02300	BAG, TOOL, 230MM	-	1	-	1	----- SWG4	

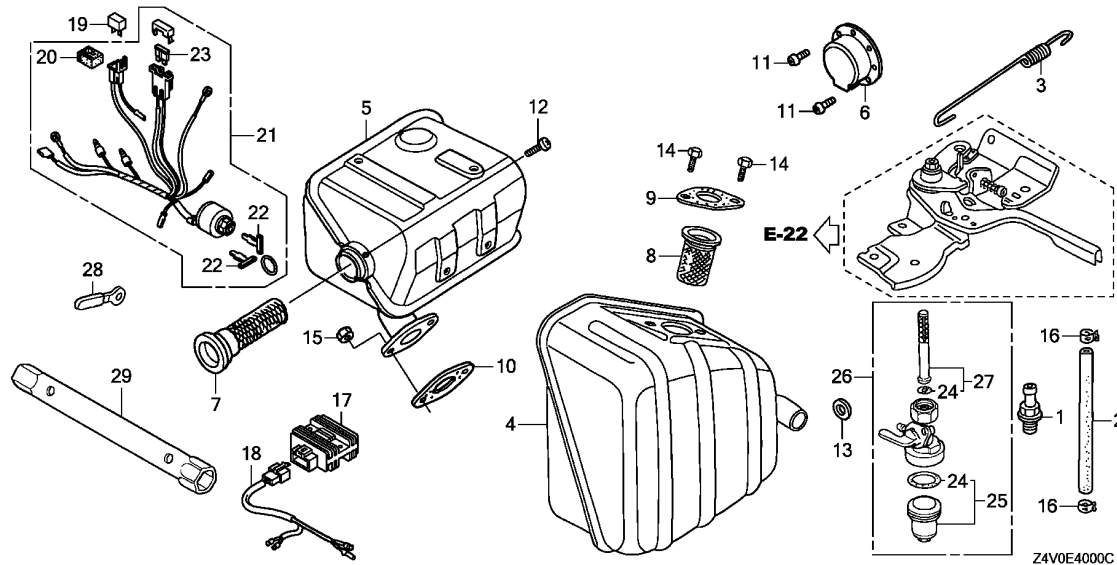

Ref. No.	L.O.N.	(Relative ref. Number) Description	F.R.T.
----------	--------	------------------------------------	--------

Ref. No.	Part No.	Description	Reqd. QTY				Serial No.	Parts catalogue code
			GX 200 UT	GX 200 RT	GX 200 UT2	GX 200 RT2		
1	15550-ZK8-P90	JOINT, DRAIN	2	-	2	-	SM12, SM14	
2	15552-ZB9-000	TUBE, DRAIN	1	-	1	-	SM12, SM14	
3	16561-ZL0-U30	SPRING, GOVERNOR	1	-	1	-	VGS5, VGS9	
	16561-ZL0-000	1	-	-	1	VPM4, VPM9	
4	18310-ZB6-C01	MUFFLER COMP.	1	-	-	1	VEE9	
	18310-ZB3-C00	1	-	-	-	VS17, VS19, VSD1	
5	18310-ZL0-000	MUFFLER COMP.	(1)	-	-	-	VS17, VSD1	
6	18331-883-810	CAP, MUFFLER	1	1	-	-	SAR, SM12, TXD1, TXDU	
		-	-	1	-	QXAG, QXC9, SAR, SM12, SM14, SM24, SXW9, TXD1, TXDU	
7	18355-ZE1-810	ARRESTER, SPARK(SILENT)	1	-	-	1	VPM4, VPM8, VPM9	
	18355-ZL0-000	ARRESTER, SPARK	(1)	-	-	-	VS17, VSD1	
8	18355-898-630	ARRESTER, SPARK	1	-	-	-	VS17, VS19, VSD1	
9	18381-Z0T-801	GASKET, MUFFLER	1	-	-	-	VEE9	
	18381-ZE1-800	1	-	-	-	VS17, VS19, VSD1	
	18381-Z0T-801	-	-	-	1	SWG4, VEE9, VPM4	
10	18381-ZH8-800	GASKET, MUFFLER	1	-	-	-	VPM4, VPM8, VPM9, VSD2	
		(1)	-	-	-	VS17, VSD1	
	18381-Z0T-801	-	1	-	-	SWG4	
11	90055-ZE1-000	SCREW, TAPPING, 4X6	2	2	-	-	SAR, SM12, TXD1, TXDU	
		-	-	2	-	QXAG, QXC9, SAR, SM12, SM14, SM24, SXW9, TXD1, TXDU	
12	90055-ZE1-000	SCREW, TAPPING, 4X6	(1)	-	-	-	VS17, VSD1	
13	90601-ZE1-000	WASHER, DRAIN PLUG, 10.2MM ..	3	-	3	-	SM12, SM14	
14	92101-08020-0A	BOLT, HEX., 8X20	2	-	-	-	VS17, VS19, VSD1	
15	94001-08000-0S	NUT, HEX., 8MM	2	2	-	2	SWG4, VEE9, VPM4, VPM8, VPM9, VSD2	
16	95002-41200-08	CLAMP, TUBE(D12)	2	-	2	-	SM12, SM14	



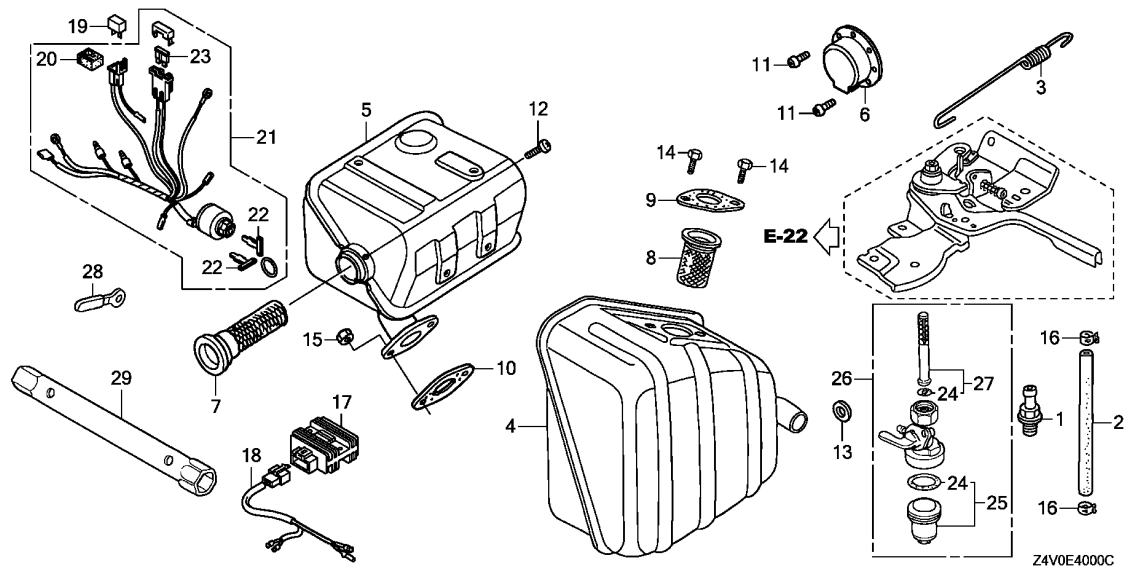

Z4V0E4000C

Ref. No.	Part No.	Description	Reqd. QTY				Serial No.	Parts catalogue code
			GX 200	GX 200	GX 200	GX 200		
			UT	RT	UT2	RT2		
17	31600-ZE2-861	RECTIFIER ASSY., REGULATOR (10A)	1	-	1	-	-----	QH4,QXE5,SXE5
18	32110-ZB5-630	HARNESS ASSY., SUB WIRE	1	-	1	-	-----	QH4,QXE5,SXE5
19	31700-124-008	RECTIFIER ASSY., SILICON (SHINDENGEN)	1	-	-	1	-----	VEE9
20	32127-738-700	SUSPENSION, COUPLER	1	-	-	1	-----	VEE9
21	35100-ZE2-033	SWITCH ASSY., COMBINATION	1	-	-	1	-----	VEE9
22	35111-880-013	KEY COMP.	2	-	-	2	-----	VEE9
23	98200-30500	FUSE, BLADE(5A)	1	-	-	1	-----	VEE9
24	16080-898-631	PACKING SET, COCK	-	-	-	1	-----	VENN
25	16081-471-831	CUP, FUEL STRAINER	-	-	-	1	-----	VENN
26	16950-898-633	COCK ASSY., FUEL	-	-	-	1	-----	VENN
27	16952-GG2-731	SCREEN SET	-	-	-	1	-----	VENN
28	32901-MA1-000	CLIP, SUB CORD	-	-	-	3	-----	SM24
29	99004-21001	WRENCH, BOX(P21)	-	-	-	1	-----	VENN

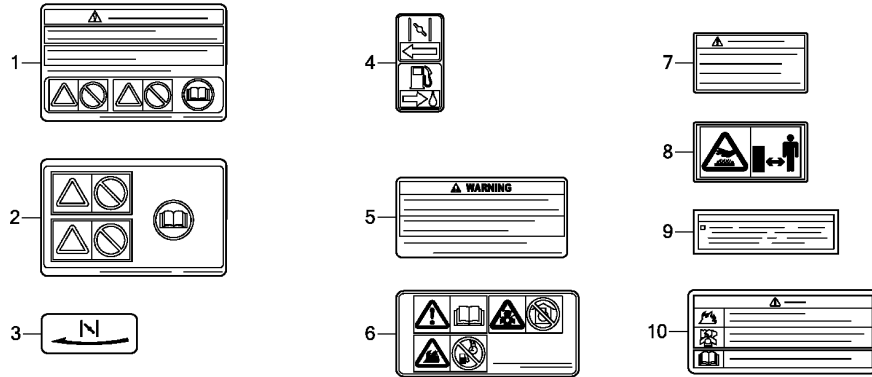

Z4V0E4001D

Ref. L.O.N. (Relative ref. Number) F.R.T.
No. Description

Ref. No.	Part No.	Description	Reqd. QTY				Serial No.	Parts catalogue code
			GX 200 UT	GX 200 RT	GX 200 UT2	GX 200 RT2		
1	87516-Z4H-800	MARK, OPERATOR CAUTION(FRENCH) (MADE IN THAI)	1	1	-	-	-----	HX2, HXU, LX2, LX4, LXAU, PXU, QG2, QH26, QH4, QHQ4, QMP4, QX2, QX26, QX4, QX7, QX9, QXB2, QXC9, QXE2, QXE4, QXE5, QXE6, QXU, RH2, RHG4, RHQ4, RMG2, RX4, RXU, SAR, SHQ4, SM12, SMC4, SWG4, SX4, SX7, SX9, SXE4, SXE5, SXU, TX2, TX4, TXD1, TXDU, TXU, TXU1, VGG2, VGGN, VGS5, VGS9, VPM4, VPM8, VPM9, VS17, VS19, VSD, VSD1, VSD2, VSD7, VSD9, VX2, VX4, VXU, VXU1
	87516-Z4H-000	MARK, OPERATOR CAUTION (ENGLISH)(MADE IN THAI)	1	-	-	-	-----	VGS5, VGS9
2	87516-Z4H-810	MARK, OPERATOR CAUTION (PICTOGRAPH)(MADE IN THAI)	(1)	-	-	-	-----	VGS5, VGS9
3	87528-ZB2-630	MARK, CHOKE	1	-	-	1	-----	VEE9, VENN, VPM8, VS17, VS19, VSD1, VSD2
4	87528-ZH7-000	MARK, CHOKE(GRAY)	1	-	-	-	-----	VGS5, VGS9
	87528-Z4M-000	MARK, CHOKE	-	-	1	-	-----	VGS5
5	87516-Z4H-801	MARK, OPERATOR CAUTION(FRENCH) (MADE IN THAI)	1	-	-	-	-----	QXD4, QXD9, SHQ2, SMC2, SMCR, VEE9
	87516-Z4H-010	MARK, OPERATOR CAUTION (ENGLISH)(MADE IN THAI)	1	-	-	-	-----	QXD4, QXD9, SMCR, VEE9
	87516-Z4H-801	MARK, OPERATOR CAUTION(FRENCH) (MADE IN THAI)	-	-	1	1	-----	
	87516-Z4H-010	MARK, OPERATOR CAUTION (ENGLISH)(MADE IN THAI)	-	-	1	1	-----	LX4, QHQ4, QMP4, QX4, QX9, QXB2, QXD4, QXD9, QXE4, QXE5, RDG4, RHG4, RHQ4, RX4, SAR, SHQ4, SM12, SMC4, SMCR, SWG4, SX4, SX9, SXE5, VEE9, VGS5, VPM4, VS19, VSD9
6	87519-Z4H-000	MARK, OPERATOR CAUTION (PICTOGRAPH)	1	-	-	-	-----	SHQ2, SMC2
			-	-	1	1	-----	HX2, LXAU, PXU, QG2, QH26, QX2, QXAG, QXC9, QXE2, RH2, RMG2, RXU, SM14, SM24, SXU, SXW9, TX2, TXD1, TXDU, VENN, VGGN, VGS5, VXU, VXU1
7	87539-Z0J-810	MARK, EX. CAUTION(FRENCH) ...	1	-	-	-	-----	QXD4, QXD9, SHQ2, SMC2, SMCR



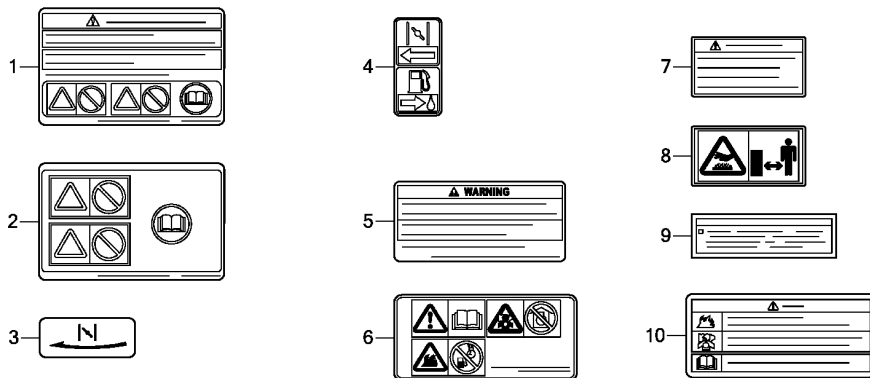

Z4V0E4001D

Ref. No.	Part No.	Description	Reqd. QTY				Serial No.	Parts catalogue code
			GX 200 UT	GX 200 RT	GX 200 UT2	GX 200 RT2		
(7)	87539-Z0J-000	MARK, EX. CAUTION(ENGLISH) ..	1	-	-	-	-----	QXD4, QXD9, SMCR
	87539-Z4M-810	MARK, EX. CAUTION(FRENCH) ...	-	-	1	1	-----	HX2, LX4, LXAU, PXU, QG2, QH26, QHQ4, QMP4, QX2, QX4, QX9, QXAG, QXB2, QXC9, QXD4, QXD9, QXE2, QXE4, QXE5, RDG4, RH2, RHG4, RHQ4, RMG2, RX4, RXU, SAR, SHQ4, SM12, SM14, SM24, SMC4, SMCR, SX4, SX9, SXE5, SXU, SXW9, TX2, TXD1, TXDU, VGGN, VGS5, VSD9, VXU, VXU1
	87539-Z4M-000	MARK, EX. CAUTION(ENGLISH) ..	-	-	1	1	-----	LX4, QHQ4, QMP4, QX4, QX9, QXB2, QXD4, QXD9, QXE4, QXE5, RDG4, RHG4, RHQ4, RMG2, RX4, SAR, SHQ4, SM12, SMC4, SMCR, SX4, SX9, SXE5, VGGN, VGS5, VSD9
8	87539-Z0J-800	MARK, EX. CAUTION(PICTOGRAPH)	1	-	-	-	-----	SHQ2, SMC2
	87539-Z4M-800	-	-	1	-	-----	HX2, LXAU, PXU, QG2, QH26, QX2, QXAG, QXC9, QXE2, RH2, RXU, SM14, SM24, SXU, SXW9, TX2, TXD1, TXDU, VXU, VXU1
9	87533-ZC0-630	MARK, AIR CLEANER(ENGLISH) ..	-	-	-	1	-----	VENN
10	87516-ZK6-800	MARK, OPERATOR CAUTION (CHINESE)	-	-	1	-	-----	QXAG, SXW9

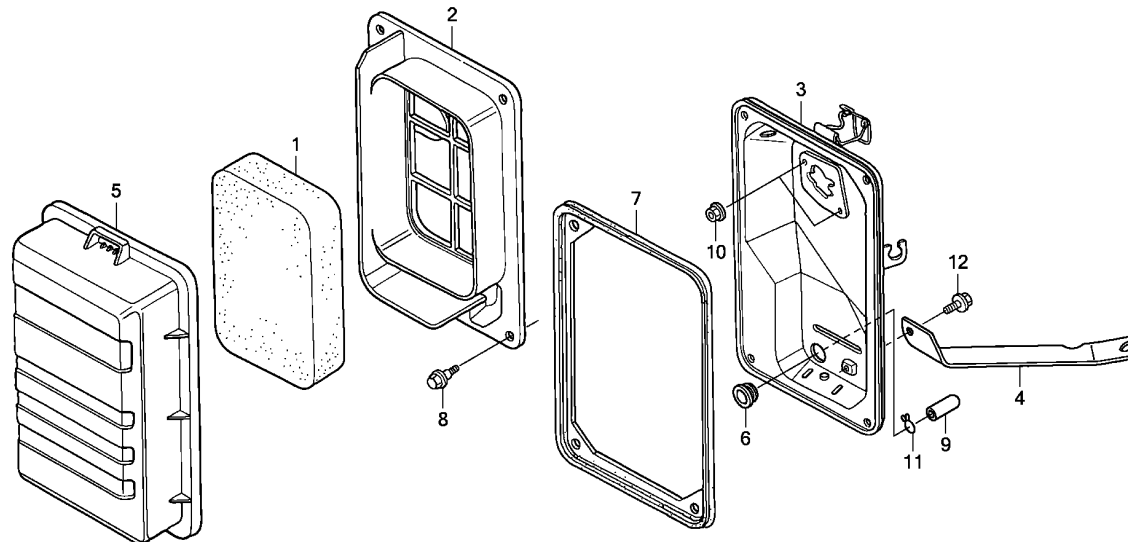

Z4V0E4002

Ref. No.	L.O.N.	(Relative ref. Number) Description	F.R.T.
----------	--------	------------------------------------	--------

Ref. No.	Part No.	Description	Reqd. QTY				Serial No.	Parts catalogue code
			GX 200 UT	GX 200 RT	GX 200 UT2	GX 200 RT2		
1	17211-ZB2-000	ELEMENT, AIR CLEANER	-	-	-	1	----- VENN	
2	17212-ZB2-800	SEPARATOR, AIR CLEANER	-	-	-	1	----- VENN	
3	17220-ZB2-800	CASE COMP., AIR CLEANER	-	-	-	1	----- VENN	
4	17222-ZL0-V30	STAY, AIR CLEANER	-	-	-	1	----- VENN	
5	17231-ZB2-000	COVER, AIR CLEANER	-	-	-	1	----- VENN	
6	17232-898-000	GROMMET, AIR CLEANER	-	-	-	1	----- VENN	
7	17252-ZB2-000	SEAL, AIR CLEANER	-	-	-	1	----- VENN	
8	90115-Z9J-000	BOLT, WINKER SETTING	-	-	-	4	----- VENN	
9	90634-ZL8-H00	CAP, SEALING	-	-	-	1	----- VENN	
10	94050-06080	NUT, FLANGE, 6MM	-	-	-	2	----- VENN	
11	95002-02100	CLIP, TUBE(B10)	-	-	-	1	----- VENN	
12	95701-06010-00	BOLT, FLANGE, 6X10	-	-	-	1	----- VENN	



E-40-3

OTHER PARTS(4)(MUFFLER)

H 7

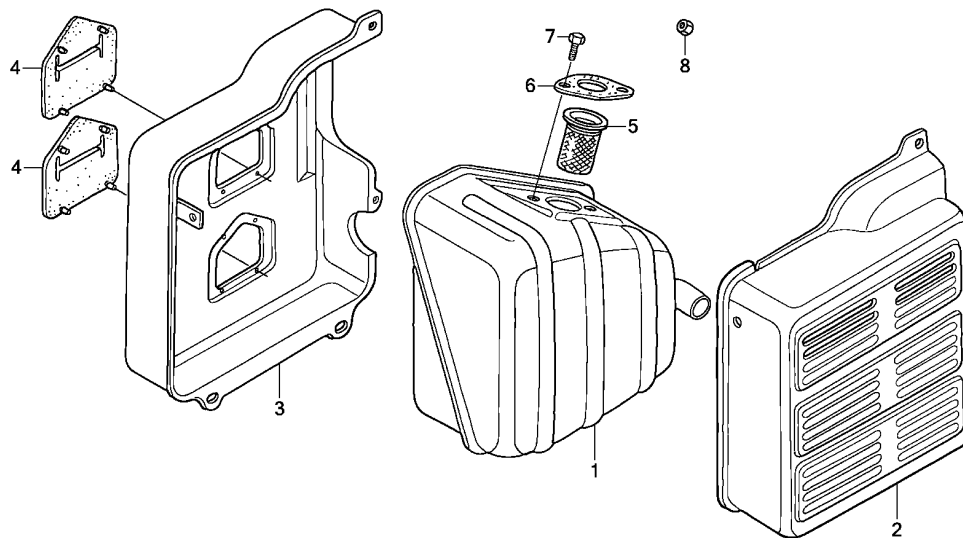

Z4V0E4003

Ref. No.	L.O.N.	(Relative ref. Number)	Description	F.R.T.
----------	--------	------------------------	-------------	--------

2

Ref. No.	Part No.	Description	Reqd. QTY				Serial No.	Parts catalogue code
			GX 200 UT	GX 200 RT	GX 200 UT2	GX 200 RT2		
1	18310-ZB3-C00	MUFFLER COMP.	-	-	-	1	----- VENN_VS19	
2	18320-ZB2-000	PROTECTOR, MUFFLER OUTER	-	-	-	1	----- VENN	
3	18325-ZH8-T90	PROTECTOR, MUFFLER INNER (DENYO)	-	-	-	1	----- VENN	
4	18329-ZB2-000	SEAL, MUFFLER PROTECTOR	-	-	-	2	----- VENN	
5	18355-898-630	ARRESTER, SPARK	-	-	-	1	----- VENN_VS19	
6	18381-Z0T-811	GASKET, MUFFLER	-	-	-	1	----- VENN_VS19	
7	92101-08020-0A	BOLT, HEX., 8X20	-	-	-	2	----- VENN_VS19	
8	94001-08000-0S	NUT, HEX., 8MM	-	-	-	2	----- VENN	

EOP-1

GASKET KIT

H 8

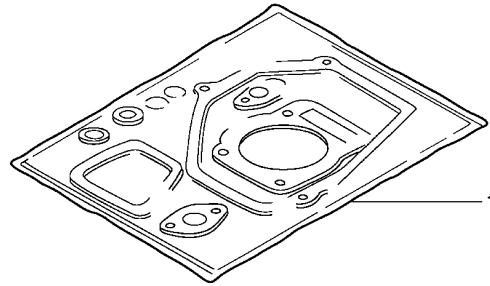

HENG-X0003

Ref. No.	L.O.N.	(Relative ref. Number)	Description	F.R.T.
----------	--------	------------------------	-------------	--------

Ref. No.	Part No.	Description	Reqd. QTY				Serial No.	Parts catalogue code
			GX 200 UT	GX 200 RT	GX 200 UT2	GX 200 RT2		
1	06111-ZL0-000	GASKET KIT	1	1	1	1		

2

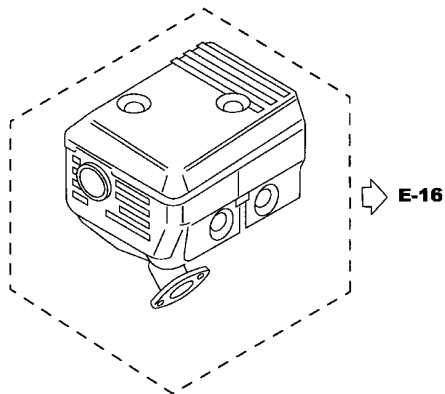
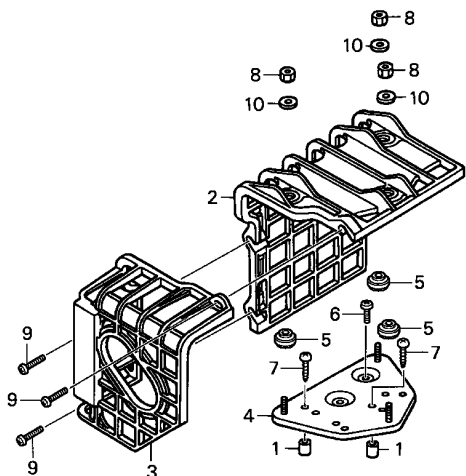

Z4V0-X0200



Ref. L.O.N. (Relative ref. Number) F.R.T.
No. Description

Ref. No.	Part No.	Description	Reqd. QTY				Serial No.	Parts catalogue code
			GX 200 UT	GX 200 RT	GX 200 UT2	GX 200 RT2		
1	17233-896-701	COLLAR, AIR CLEANER CASE	(2)	(2)	(2)	(2)	LX4, QHQ4, QMP4, QX4, QX7, QX9, QXD4, QXD9, QXE4, QXE5, RDG4, RHG4, RHQ4, RX4, SHQ2, SHQ4, SM24, SMC2, SMC4, SMCR, SX4, SX7, SX9, SXE4, SXE5, TX4, VGS5, VGS9, VSD, VSD1, VSD2, VSD7, VSD9, VX4	
2	18433-ZH8-W40	COVER COMP., MUFFLER	(1)	(1)	(1)	(1)	LX4, QHQ4, QMP4, QX4, QX7, QX9, QXD4, QXD9, QXE4, QXE5, RDG4, RHG4, RHQ4, RX4, SHQ2, SHQ4, SM24, SMC2, SMC4, SMCR, SX4, SX7, SX9, SXE4, SXE5, TX4, VGS5, VGS9, VSD, VSD1, VSD2, VSD7, VSD9, VX4	
3	18434-ZH8-W40	COVER COMP., RR. MUFFLER	(1)	(1)	(1)	(1)	LX4, QHQ4, QMP4, QX4, QX7, QX9, QXD4, QXD9, QXE4, QXE5, RDG4, RHG4, RHQ4, RX4, SHQ2, SHQ4, SM24, SMC2, SMC4, SMCR, SX4, SX7, SX9, SXE4, SXE5, TX4, VGS5, VGS9, VSD, VSD1, VSD2, VSD7, VSD9, VX4	
4	18436-ZH8-W40	BASE COMP., MUFFLER COVER	(1)	(1)	-	(1)	LX4, QHQ4, QMP4, QX4, QX7, QX9, QXD4, QXD9, QXE4, QXE5, RHG4, RHQ4, RX4, SHQ2, SHQ4, SMC2, SMC4, SMCR, SX4, SX7, SX9, SXE4, SXE5, TX4, VGS5, VGS9, VSD, VSD1, VSD2, VSD7, VSD9, VX4	
	18436-ZH8-W41	-	-	(1)	(1)	RDG4, SMCR	
	18436-ZH8-W40	-	-	(1)	-	LX4, QHQ4, QMP4, QX4, QX9, QXD4, QXD9, QXE4, QXE5, RHQ4, RX4, SHQ4, SM24, SMC4, SX4, SX9, SXE5, VGS5, VSD9	
5	18466-ZH8-W40	SPACER, MUFFLER COVER	(3)	(3)	(3)	(3)	LX4, QHQ4, QMP4, QX4, QX7, QX9, QXD4, QXD9, QXE4, QXE5, RDG4, RHG4, RHQ4, RX4, SHQ2, SHQ4, SM24, SMC2, SMC4, SMCR, SX4, SX7, SX9, SXE4, SXE5, TX4, VGS5, VGS9, VSD, VSD1, VSD2, VSD7, VSD9, VX4	
6	90050-ZE1-000	SCREW, TAPPING, 5X8	(1)	(1)	(1)	(1)	LX4, QHQ4, QMP4, QX4, QX7, QX9, QXD4, QXD9, QXE4, QXE5, RDG4, RHG4, RHQ4, RX4, SHQ2, SHQ4, SM24, SMC2, SMC4, SMCR, SX4, SX7, SX9, SXE4, SXE5, TX4, VGS5, VGS9, VSD, VSD1, VSD2, VSD7, VSD9, VX4	
7	90050-ZH8-W40	SCREW, TAPPING, 5X25	(2)	(2)	(2)	(2)	LX4, QHQ4, QMP4, QX4, QX7, QX9, QXD4, QXD9, QXE4, QXE5, RDG4, RHG4, RHQ4, RX4, SHQ2, SHQ4, SM24, SMC2, SMC4, SMCR, SX4, SX7, SX9, SXE4, SXE5, TX4, VGS5, VGS9, VSD, VSD1, VSD2, VSD7, VSD9, VX4	
8	90302-KF9-900	NUT, HEX., 5MM	(3)	(3)	(3)	(3)	LX4, QHQ4, QMP4, QX4, QX7, QX9, QXD4, QXD9, QXE4, QXE5, RDG4, RHG4, RHQ4, RX4, SHQ2, SHQ4, SM24, SMC2, SMC4, SMCR, SX4, SX7, SX9, SXE4, SXE5, TX4, VGS5, VGS9, VSD, VSD1, VSD2, VSD7, VSD9, VX4	

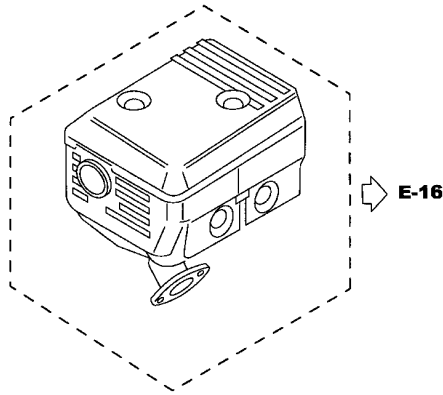
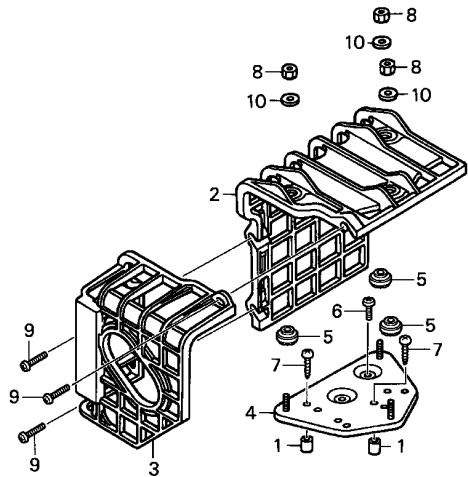

Z4V0--X0200



Ref. No.	Part No.	Description	Reqd. QTY				Serial No.	Parts catalogue code
			GX 200 UT RT	GX 200 RT	GX 200 UT2	GX 200 RT2		
9	93891-06020-07	SCREW-WASHER, 6X20	(3)	(3)	(3)	(3)	-----	LX4, QHQ4, QMP4, QX4, QX7, QX9, QXD4, QXD9, QXE4, QXE5, RDG4, RHG4, RHQ4, RX4, SHQ2, SHQ4, SM24, SMC2, SMC4, SMCR, SX4, SX7, SX9, SXE4, SXE5, TX4, VGS5, VGS9, VSD, VSD1, VSD2, VSD7, VSD9, VX4
10	94103-05700	WASHER, PLAIN, 5MM	(3)	(3)	(3)	(3)	-----	LX4, QHQ4, QMP4, QX4, QX7, QX9, QXD4, QXD9, QXE4, QXE5, RDG4, RHG4, RHQ4, RX4, SHQ2, SHQ4, SM24, SMC2, SMC4, SMCR, SX4, SX7, SX9, SXE4, SXE5, TX4, VGS5, VGS9, VSD, VSD1, VSD2, VSD7, VSD9, VX4



PART NO. INDEX

Part Number	Address	Page	Ref.	Part Number	Address	Page	Ref.	Part Number	Address	Page	Ref.	Part Number	Address	Page	Ref.
17222-ZL0-V30	F1	56	4	18000				19610-ZL0-000ZJ	E3	42	1	28400-ZH8-023ZB	D15	38	1
	H6	93	4					19610-ZL0-820ZF	E3	42	2	28400-ZH8-033YA	D15	38	1
17230-ZE1-820	E15	54	4	18310-Z4M-V90	F6	61	16	19610-ZL0-830ZA	E3	42	2	28400-ZH8-033ZB	D15	38	1
17230-ZE1-841	F3	58	5	18310-Z4V-000	F6	61	16	19610-ZL0-830ZD	E3	42	2	28405-ZL0-000ZA	D16	39	2
17231-Z4M-000	E16	55	15	18310-Z4V-800	F6	61	16	19610-ZL0-830ZE	E3	42	2	28405-ZL0-000ZC	D16	39	2
17231-Z4M-010	E16	55	15	18310-Z8K-870	F4	59	1	19611-Z4M-810	E4	43	3	28410-Z4M-003ZB	D16	39	3
17231-ZB2-000	F1	56	5	18310-ZB3-C00	H2	89	4	19611-Z4M-820	E4	43	3	28410-Z4M-003ZD	D16	39	3
	H6	93	5					19611-ZH8-810	E4	43	3	28410-ZH8-003YA	D16	39	3
17232-891-000	E15	54	5	18310-ZB6-C01	H2	89	4	19611-ZH8-820	E4	43	3	28410-ZH8-003ZB	D16	39	3
	F3	58	6	18310-ZH7-V90	F6	61	15	19612-Z4M-000	E4	43	3	28414-ZK8-V71	E2	41	16
17232-898-000	H6	93	6	18310-ZL0-000	F4	59	1	19612-Z4M-820	E4	43	3	28421-Z0T-003	D16	39	4
17233-896-701	H9	96	1					19612-Z4M-840	E4	43	4	28422-ZH8-801	D16	39	5
17235-Z4M-830	E16	55	6	18310-ZL0-800	F4	59	1	19612-ZH8-000	E4	43	3	28431-ZH8-801	E1	40	6
17235-Z4M-860	E16	55	6	18315-ZE1-000	F4	59	2	19612-ZH8-821	E4	43	3	28433-ZH8-801	E1	40	7
17235-ZE1-831	E16	55	6	18320-Z4M-000	F4	59	3	19612-ZH8-840	E4	43	4	28441-ZH8-801	E1	40	8
17235-ZE1-860	E15	54	6	18320-Z4V-000	F4	59	3	19613-ZE1-020	E5	44	17	28442-ZH8-801	E1	40	9
17238-ZE7-010	E16	55	7	18320-ZB2-000	H7	94	2	19620-ZL0-V30	E5	44	18	28443-ZH8-801	E2	41	10
	F2	57	2	18320-ZF1-H01	F4	59	3	19630-ZH8-000	E4	43	5	28450-ZL0-801	F13	68	3
	F3	58	7	18320-ZF1-H51	F4	59	3	19640-ZL0-V30	E4	43	5	28451-ZL0-000	F13	68	4
17239-733-000	F3	58	8	18320-ZF1-H52	F4	59	3					28451-ZL0-801	F13	68	4
17239-ZE1-000	E16	55	8	18325-ZH8-T90	H7	94	3	21000				28461-Z4M-305	E2	41	17
	F2	57	3	18329-ZB2-000	H7	94	4	21510-883-621	G11	82	2	28461-ZH8-003	E2	41	11
17252-ZB2-000	F1	56	6	18330-ZB2-000	F7	62	1	21521-883-741	G13	84	1	28462-ZH8-003	E2	41	12
	H6	93	7	18331-883-810	F6	61	13	21591-ZH8-620	G11	82	3	28463-Z4M-003	E2	41	18
17401-ZE1-810	F2	57	4					21610-822-611	G11	82	4				
17402-ZE1-810	F2	57	5	18355-898-630	H2	89	8	21621-883-741	G13	84	3	30000			
17403-ZE1-810	F2	57	6					21691-ZH8-800	G11	82	5	30500-Z0T-801	F14	69	1
17404-841-000	F2	57	7	18355-ZE1-810	H2	89	7	21692-ZH7-000	G13	84	4	30500-Z0T-802	F14	69	1
17410-Z4M-000	E16	55	9	18355-ZL0-000	F5	60	4	21692-ZH8-800	G13	84	4	30700-Z0T-811	F14	69	2
17410-ZE1-020	E16	55	9									30700-ZF5-013	F14	69	2
	F2	57	8	18361-ZL0-000	F5	60	5	22000							
17410-ZE1-840	F3	58	9	18381-Z0T-801	F5	60	6	22121-883-620	G11	82	6	31000			
17421-ZE1-000	F2	57	9					22201-822-610	G11	82	7	31100-ZE7-010	F13	68	5
17470-ZE1-842	F3	58	10					22311-822-610	G11	82	8	31110-ZL0-811	F13	68	5
17475-ZE1-841	F3	58	11					22350-822-610	G11	82	9	31110-ZL0-821	F13	68	6
17476-ZE1-841	F3	58	12	18381-Z0T-811	H7	94	6	22411-822-611	G11	82	10	31110-ZL0-U52	F13	68	6
17478-ZE1-841	F3	58	13	18381-ZE1-800	H2	89	9	22421-822-610	G11	82	11	31200-ZL0-811	F16	71	1
17510-Z0T-000ZA	F8	63	5	18381-ZH8-800	F5	60	6	22521-822-610	G11	82	12	31204-ZE1-003	F16	71	2
17510-Z0T-000ZC	F8	63	5					22531-883-620	G11	82	13	31204-ZE1-013	F16	71	2
17510-Z0T-010ZA	F8	63	5					22535-822-610	G11	82	14	31206-KN7-670	F16	71	3
	F9	64	5	18433-ZH8-W40	H9	96	2					31206-Z4M-003	F16	71	3
17510-Z0T-010ZC	F8	63	5	18434-ZH8-W40	H9	96	3	23000				31210-Z4M-003	F16	71	4
17510-Z4M-000ZA	F12	67	3	18436-ZH8-W40	H9	96	4	23110-ZE1-610	G10	81	4	31210-ZE1-723	F16	71	4
17510-Z4M-000ZB	F12	67	3	18436-ZH8-W41	H9	96	4	23120-883-620	G11	82	15	31212-Z4M-003	F16	71	5
17620-Z0T-813	F9	64	6	18466-ZH8-W40	H9	96	5	23161-822-611	G11	82	16	31212-ZE1-003	F16	71	5
17620-Z4H-000	F10	65	19					23710-883-740	G13	84	5	31214-Z4M-003	F16	71	6
17620-Z4H-010	F10	65	19	19000				23710-ZE1-613	G10	81	5	31214-ZE1-003	F16	71	6
17620-Z4H-020	F10	65	19					23711-822-610	G11	82	17	31215-Z4M-003	F16	71	7
	F12	67	4	19511-ZE1-000	F13	68	2					31215-ZE1-003	F16	71	7
17620-Z4H-030	F12	67	4	19610-Z0V-880ZA	E3	42	1					31216-Z4M-003	F16	71	8
17631-Z0T-801	F9	64	7	19610-Z0V-880ZB	E3	42	1	28400-Z0T-003ZA	D15	38	1	31216-ZE1-731	F16	71	8
	F11	66	20	19610-Z4M-000ZA	E3	42	1	28400-Z4M-305ZB	D15	38	1	31217-ZE1-722	F16	71	9
	F12	67	5	19610-Z4M-000ZB	E3	42	1	28400-Z4M-305ZD	D16	39	1	31220-Z4M-003	F16	71	10
17631-Z4H-800	F11	66	20	19610-Z4M-000ZD	E3	42	1	28400-ZH8-023YA	D15	38	1				
17672-Z4H-000	F11	66	21	19610-Z4M-820ZB	E3	42	2								
	F12	67	6	19610-Z4M-830ZB	E3	42	2								
17672-ZE2-W01	F9	64	8	19610-Z4M-830ZD	E3	42	2								
				19610-ZL0-000ZA	E3	42	1								
				19610-ZL0-000ZD	E3	42	1								



PART NO. INDEX

Part Number	Address	Page	Ref.	Part Number	Address	Page	Ref.	Part Number	Address	Page	Ref.	Part Number	Address	Page	Ref.
96000															
96100-62040-00	G13	84	12												
96100-62050-00	D6	29	10												
	G10	81	14												
	G12	83	30												
96100-62060-00	G12	83	31												
96100-63050-00	G13	84	13												
98000															
98079-55846	D2	25	15												
98079-55855	D2	25	15												
98079-55876	D2	25	15												
98079-56846	D2	25	15												
98079-56855	D2	25	15												
98079-56876	D2	25	15												
98200-30500	G9	80	26												
	H3	90	23												
98200-31500	G9	80	26												
99000															
99001-10120	H1	88	4												
99001-14170	H1	88	5												
99004-21001	H3	90	29												
99008-02300	H1	88	6												
99101-ZH8-0680	E10	49	25												
99101-ZH8-0700	E10	49	25												
99101-ZH8-0720	E11	50	25												
	E14	53	18												
99101-ZH8-0750	E11	50	25												
	E14	53	18												
99101-ZH8-0780	E14	53	18												
99204-ZA0-0450	E11	50	26												
99204-ZE2-0400	E11	50	26												
	E14	53	19												

PART NAME INDEX

J 1

Part name	Address	Page	Ref.	Part name	Address	Page	Ref.	Part name	Address	Page	Ref.
[A]											
ALERT UNIT, OIL	E4	43	6	BOLT, FLANGE, 6X8	E5	44	12	CHAMBER SET, FLOAT	E13	52	4
	G8	79	9	BOLT, FLANGE, 8X22	G12	83	29	CHOKE SET	E8	47	8
ARM COMP., GOVERNOR	G6	77	32	BOLT, FLANGE, 8X32	D6	29	9		E13	52	8
ARM, GOVERNOR	G3	74	5		G13	84	10	CIRCLIP, 10.2MM	G1	72	27
ARM, VALVE ROCKER	D12	35	4	BOLT, FLANGE, 8X35	G13	84	11	CIRCLIP, 5MM	E12	51	32
ARRESTER, SPARK	F5	60	4	BOLT, FLANGE, 8X60	D2	25	14		G6	77	24
	H2	89	7	BOLT, GOVERNOR ARM	G6	77	21	CLAMPER, CORD	F14	69	4
				BOLT, HEX., 5/16"	D7	30	9	CLAMP, CORD	E5	44	17
	H7	94	5	BOLT, HEX., 8X20	H2	89	14	CLAMP, TUBE	F10	65	17
					H7	94	7				
				BOLT, HEX., 8X25	D7	30	9		F12	67	11
					G10	81	12		H2	89	16
[B]											
BAG, TOOL, 230MM	H1	88	6	BOLT, HEX., 8X35	G11	82	23	CLIP, CORD	G9	80	17
BAND	G8	79	8	BOLT, MUDGUARD	F3	58	14	CLIP, GOVERNOR HOLDER	D3	26	9
BARREL ASSY., CYLINDER	D3	26	1	BOLT, PIVOT, 8MM	D14	37	15	CLIP, HARNESS	E4	43	11
BASE COMP., CONTROL	G4	75	15	BOLT, SETTING	G1	72	21	CLIP, PISTON PIN, 18MM	D11	34	6
	G5	76	15	BOLT, STUD, 6X112	D2	25	11	CLIP, PURSE LOCK	E5	44	15
BASE COMP., MUFFLER COVER	H9	96	4	BOLT, STUD, 6X94	D2	25	11		G9	80	16
BEARING, RADIAL BALL	D3	26	10	BOLT, STUD, 8X32	D2	25	12	CLIP, SUB CORD	E2	41	13
	D4	27	10	BOLT, WINKER SETTING	F1	56	7		H3	90	28
BEARING, RADIAL BALL, 6204 ...	G13	84	12		H6	93	8	CLIP, TUBE	D2	25	16
BEARING, RADIAL BALL, 6205 ...	D6	29	10	BOX ASSY., CONTROL	G8	79	1		E12	51	36
	G10	81	14	BRACKET COMP., FR.	G1	72	16		E16	55	14
	G12	83	30	BRACKET, CASE MOUNTING	G8	79	3		F10	65	16
	G12	83	31	[C]					H6	93	11
BEARING, RADIAL BALL, 6206 ...	G12	83	31	CABLE, DOUBLE CONNECTOR	E5	44	14	CLIP, VALVE GUIDE	D1	24	4
BEARING, RADIAL BALL, 6305 ...	G13	84	13	CAMSHAFT ASSY.	D12	35	2	CLIP, WIRE HARNESS, 25MM	G7	78	8
BODY, CLEANER	F2	57	4	CAP ASSY., NOISE SUPPRESSOR ...	F14	69	2	COCK ASSY., FUEL	H3	90	26
BOLT, BREATHING	G13	84	6	CAP ASSY., OIL FILLER	D5	28	4	COIL ASSY., CHARGE	F14	69	6
BOLT, CONNECTING ROD	D11	34	5						F15	70	13
BOLT, DRAIN PLUG	D3	26	6		D6	29	5	COIL ASSY., IGNITION	F14	69	1
BOLT, DRAIN PLUG, 12MM	G11	82	24		G11	82	1	COIL ASSY., LAMP	F14	69	3
BOLT, DRAIN PLUG, 12X15	G13	84	7	CAP COMP., FUEL FILLER	F9	64	6		F15	70	12
BOLT, FLANGE, 5X10	F15	70	10		F10	65	19	COLLAR B, AIR CLEANER	E16	55	8
BOLT, FLANGE, 6X10	F1	56	9		F12	67	4		F2	57	3
	G9	80	25	CAP, BOOST	E12	51	35	COLLAR, AIR CLEANER	E16	55	7
	H6	93	12	CAP, CLEANER	F2	57	9		F3	58	8
BOLT, FLANGE, 6X12	D1	24	10	CAP, MUFFLER	F6	61	13	COLLAR, AIR CLEANER CASE	H9	96	1
	D4	27	16		H2	89	6	COLLAR, STOPPER	G5	76	19
	E4	43	9	CAP, PRE AIR CLEANER	F3	58	11	CONDENSER UNIT	G7	78	4
	F6	61	12	CAP, SEALING	E16	55	13	CONTROL ASSY.	G3	74	1
	G6	77	20		H6	93	9				
BOLT, FLANGE, 6X13	F5	60	7	CARBURETOR ASSY.	E8	47	9				
BOLT, FLANGE, 6X16	G7	78	12		E13	52	9				
BOLT, FLANGE, 6X18	E2	41	15	CASE B, STARTER	E2	41	16				
BOLT, FLANGE, 6X20	E4	43	10	CASE COMP., AIR CLEANER	F1	56	3		G4	75	9
	E16	55	12		H6	93	3		G6	77	30
	F2	57	12	CASE COMP., RECOIL STARTER	D16	39	3				
	F3	58	17	CASE, CONTROL	G8	79	2	CORD, MAGNET SWITCH	G1	72	17
BOLT, FLANGE, 6X25	F15	70	11	CASE, PRE AIR CLEANER	F3	58	10	CORD, STOP SWITCH	F15	70	8
	G1	72	25	CASE, REDUCTION	G11	82	2	COVER ASSY., CHAIN CASE	G10	81	1
	G7	78	13		G13	84	1	COVER ASSY., CRANKCASE	D5	28	1
BOLT, FLANGE, 6X28	F15	70	9	CENTER, CLUTCH	G11	82	6				
	G10	81	6	CENTER, CLUTCH WEIGHT	G11	82	14	COVER COMP., FAN	E3	42	1
BOLT, FLANGE, 6X32	G1	72	22	CHAIN, DRIVE	G11	82	16				
BOLT, FLANGE, 6X34	F9	64	9	CHAIN, P.T.O. DRIVE	G10	81	3	COVER COMP., GEAR	F16	71	5
	F12	67	7	CHAMBER SET, FLOAT	E6	45	4	COVER COMP., HEAD	D1	24	6
BOLT, FLANGE, 6X55	G12	83	28								

PART NAME INDEX

J 2

Part name	Address	Page	Ref.	Part name	Address	Page	Ref.	Part name	Address	Page	Ref.
COVER COMP., MUFFLER	H9	96	2	FUSE, BLADE	H3	90	23	JET, MAIN, #75	E11	50	25
COVER COMP., RR. MUFFLER	H9	96	3						E14	53	18
COVER, AIR CLEANER	E15	54	4	[G]				JET, MAIN, #78	E14	53	18
	E16	55	15					JOINT, DRAIN	H2	89	1
	F1	56	5	GASKET KIT	H8	95	1	JOINT, FUEL TANK	F8	63	4
	F3	58	5	GASKET SET	E6	45	1		F12	67	2
	H6	93	5		E13	52	1	[K]			
COVER, MAGNETIC SWITCH	G1	72	18	GASKET, CYLINDER HEAD	D1	24	5	KEY COMP.	G8	79	11
COVER, REDUCTION	G11	82	4	GASKET, MUFFLER	F5	60	6		H3	90	22
	G13	84	3		F7	62	2	KEY, 4.78X4.78X38	D7	30	8
COVER, SPRING	F16	71	14		H2	89	9	KEY, 5MM	G11	82	19
	G1	72	14				10	KEY, 5X5X33	D7	30	8
COVER, STARTER MOTOR TERMINAL	G1	72	19		H7	94	6		G10	81	10
CRANKSHAFT COMP.	D7	30	1	GEAR ASSY.	G1	72	15	KEY, 7X7X33	G11	82	20
			2	GOVERNOR ASSY.	D3	26	3	KEY, SPECIAL WOODRUFF, 25X18	F13	68	1
			3	GRID, AIR CLEANER	F2	57	7	KNOB, RECOIL STARTER	E2	41	17
			4	GRIP, STARTER	E2	41	11	KNOB, REINFORCEMENT	E2	41	18
			5	GROMMET, AIR CLEANER	E15	54	5				
			6		F3	58	6	[L]			
			10		H6	93	6	LABEL, AIR CLEANER CAUTION	G15	86	7
			11	GROMMET, CORD	F14	69	5	LENS ASSY., PROTECTOR	G9	80	13
CUP, FUEL STRAINER	E10	49	22	GROMMET, DRAIN HOLE	E5	44	13	LEVER COMP., CHOKE	E9	48	17
	H3	90	25	GUIDE, EX. VALVE	D1	24	2		E11	50	29
[D]				GUIDE, IN. VALVE	D1	24	1		E14	53	16
DISK, CLUTCH FRICTION	G11	82	7	GUIDE, PRE AIR CLEANER	F3	58	12	LEVER, COCK	E10	49	18
DOWEL PIN, 10X16	D2	25	13	GUIDE, PUSH ROD	D14	37	18	LEVER, CONTROL	G4	75	10
DOWEL PIN, 8X10	G2	73	34	GUIDE, RATCHET	E1	40	7	LEVER, SOLENOID THROTTLE	G7	78	3
	G12	83	27	[H]				LIFTER, VALVE	D13	36	9
DOWEL PIN, 8X14	D6	29	8	HANDLE, BOX WRENCH	H1	88	2				
	G10	81	13	HARNESS ASSY., SUB WIRE	H3	90	18	[M]			
[E]				HARNESS, SUB WIRE	G8	79	7	MARK, AIR CLEANER	H5	92	9
ELBOW COMP., AIR CLEANER	E16	55	9	HEAD COMP., CYLINDER	D1	24	3	MARK, AIR CLEANER SALES POINT	G16	87	8
	F2	57	8	HOLDER, CABLE	E12	51	31	MARK, CHOKE	G15	86	3
	F3	58	9		G4	75	13				4
ELEMENT, AIR CLEANER	E15	54	2	HOLDER, CLUTCH SPRING	G11	82	11		H4	91	3
	F1	56	1	HOLDER, CLUTCH WEIGHT	G11	82	13				4
	F2	57	6	HOLDER, CONTROL CABLE	E11	50	27	MARK, CONTROL BOX	G9	80	14
	F3	58	2	HOLDER, HARNESS	G1	72	28	MARK, EX. CAUTION	G16	87	9
	H6	93	1	HOLDER, WIRE	G5	76	18				10
EMBLEM	G14	85	2	[I]					H4	91	7
[F]				INSULATOR COMP., CARBURETOR ...	E12	51	37		H5	92	7
FAN, COOLING	F13	68	2	INSULATOR, CARBURETOR	E8	47	13	MARK, OPERATOR CAUTION	G14	85	1
FILTER, CUP	E12	51	39		E12	51	38		G15	86	6
FILTER, FUEL	F9	64	8		E13	52	12		H4	91	1
	F11	66	21	[J]							2
	F12	67	6	JET SET, PILOT, #40	E11	50	26				5
FILTER, OUTER	E15	54	3		E14	53	19		H5	92	10
	F3	58	3	JET SET, PILOT, #45	E11	50	26	MARK, THROTTLE INDICATION	G15	86	5
FLOAT SET	E6	45	3	JET, MAIN, #68	E10	49	25	MOTOR ASSY., STARTER	F16	71	1
	E13	52	3	JET, MAIN, #70	E10	49	25	MOTOR ONLY	F16	71	10
FLYWHEEL COMP.	F13	68	5	JET, MAIN, #72	E11	50	25	MOTOR UNIT, STARTER	F16	71	4
			6		E14	53	18	MUFFLER COMP.	F4	59	1
FUSE, BLADE	G9	80	26						F6	61	15

4

PART NAME INDEX

J 3

Part name	Address	Page	Ref.	Part name	Address	Page	Ref.	Part name	Address	Page	Ref.
MUFFLER COMP.	F6	61	16	PACKING, CHAIN CASE COVER	G10	81	2	RETAINER, EX. VALVE SPRING	D13	36	12
	H2	89	4	PACKING, ELBOW	E15	54	1	RETAINER, IN. VALVE SPRING	D13	36	11
			5		F2	57	1	RING SET, PISTON	D8	31	1
	H7	94	1		F3	58	1		D9	32	1
[N]				PACKING, FUEL COCK	E10	49	21		D10	33	1
NETTING, WIRE FLANGE	F5	60	5	PACKING, FUEL FILLER CAP	F9	64	7	ROD ASSY., CONNECTING	D11	34	4
NOSE, SILENCER	E15	54	6		F11	66	20	ROD COMP., PUSH	D14	37	17
	E16	55	6		F12	67	5	ROD, GOVERNOR	G3	74	6
NOZZLE, MAIN	E8	47	11	PACKING, FUEL STRAINER CUP	E8	47	12		G4	75	6
	E13	52	11	PACKING, HEAD COVER	D1	24	7	ROD, PUSH	D12	35	3
	G1	72	23	PACKING, INSULATOR	E9	48	14	ROPE, RECOIL STARTER	E2	41	12
NUT-WASHER, 6MM	E16	55	16		E13	52	13	ROTATOR, VALVE	D13	36	13
NUT, AIR CLEANER	D4	27	13	PACKING, OIL FILLER CAP	D6	29	6	ROTOR ASSY.	F16	71	9
NUT, FLANGE, 10MM	E16	55	11				11	RUBBER, FUEL	F9	64	10
NUT, FLANGE, 6MM	F1	56	8	PACKING, REDUCTION CASE	G11	82	3	RUBBER, SUPPORTER	F8	63	1
	F2	57	11		G13	84	2				
	F3	58	16	PACKING, REDUCTION COVER	G11	82	5		F12	67	1
	F10	65	12		G13	84	4	[S]			
	F12	67	10	PANEL COMP., CONTROL	G8	79	4	SCREEN SET	H3	90	27
	G6	77	29	PAN, CLEANER OIL	F2	57	5	SCREW-WASHER, 5X14	G2	73	32
	G7	78	10	PIECE A, STOPPER	F16	71	11	SCREW-WASHER, 5X20	G2	73	33
	H6	93	10	PIECE B, STOPPER	F16	71	12	SCREW-WASHER, 5X30	G1	72	24
NUT, HEX., 4MM	G9	80	22	PINION ASSY.	F16	71	6	SCREW-WASHER, 5X8	G1	72	20
NUT, HEX., 5MM	H9	96	8	PIN, LOCK, 8MM	D4	27	15	SCREW-WASHER, 6X20	H10	97	9
NUT, HEX., 8MM	F6	61	11	PIN, PISTON	D11	34	3	SCREW SET	E7	46	7
	F7	62	3	PIN, SPRING, 2X12	E10	49	24		E13	52	7
	H2	89	15		E14	53	17	SCREW SET, DRAIN	E7	46	6
	H7	94	8	PIN, SPRING, 2X6	G7	78	11		E13	52	6
NUT, PIVOT ADJUSTING	D14	37	16	PIPE COMP., EX.	F7	62	1	SCREW SET, PILOT	E7	46	5
NUT, SELF-LOCK, 6MM	G6	77	23	PISTON	D10	33	2		E13	52	6
NUT, SPECIAL, 14MM	F13	68	7		D11	34	2		E7	46	5
NUT, TOOL BOX SETTING	E16	55	10	PIVOT, ROCKER ARM	D12	35	5	SCREW, PAN, 3X12	G9	80	20
	F2	57	10	PLATE COMP., CLUTCH PRESSURE ..	G11	82	9	SCREW, PAN, 3X6	E10	49	23
	F3	58	15	PLATE COMP., SIDE	E4	43	3	SCREW, PAN, 4X12	G9	80	21
[O]				PLATE, CLUTCH	G11	82	8	SCREW, PAN, 4X6	G6	77	25
OIL SEAL, 25X41X6	D4	27	11	PLATE, FRICTION	E1	40	6	SCREW, PAN, 4X8	E12	51	33
	D6	29	7	PLATE, LEVER SETTING	E10	49	19	SCREW, PAN, 5X16	G6	77	26
	G10	81	11	PLATE, PRE AIR CLEANER	F3	58	13	SCREW, PAN, 5X25	G6	77	27
	G13	84	8	PLATE, PUSH ROD GUIDE	D14	37	14	SCREW, PAN, 5X35	E5	44	19
OIL SEAL, 30X50X7	G11	82	21					SCREW, PAN, 5X8	E12	51	34
O-RING	F16	71	3	PLATE, SIDE	E4	43	3		G1	72	20
	G2	73	29				4	SCREW, PAN, 5X8	E12	51	34
O-RING, 14MM	D4	27	12	PLUG, SPARK	D2	25	15		G7	78	9
	F9	64	11	PROTECTOR COMP., MUFFLER	F4	59	3	SCREW, RECESSED, 5X25	G6	77	22
	F12	67	8	PROTECTOR, CIRCUIT	G9	80	12	SCREW, SETTING	E2	41	14
O-RING, 26X2.7	G11	82	22	PROTECTOR, MUFFLER	F4	59	3	SCREW, SPECIAL, 6X12	G9	80	15
				PROTECTOR, MUFFLER INNER	H7	94	3	SCREW, TAPPING, 4X6	F6	61	9
				PROTECTOR, MUFFLER OUTER	H7	94	2				
				PROTECTOR, MUFFLER OUTER	H7	94	2				
				PULLEY COMP., STARTER	F13	68	3				
				PULLEY, STARTER	F13	68	4				
									H2	89	11
[P]				[R]				SCREW, TAPPING, 5X25	H9	96	7
PACKING SET, COCK	H3	90	24	RATCHET, STARTER	D16	39	5	SCREW, TAPPING, 5X8	F6	61	8
PACKING, AIR CLEANER	E14	53	15	RECTIFIER ASSY., REGULATOR	G7	78	5		H9	96	6
PACKING, AIR CLEANER COVER	F3	58	4		H3	90	17	SCREW, THROTTLE STOP	E8	47	10
PACKING, CARBURETOR	E9	48	16	RECTIFIER ASSY., SILICON	G8	79	5		E13	52	10
	E13	52	14		H3	90	19	SEAL, AIR CLEANER	F1	56	6
PACKING, CASE COVER	D5	28	3	REEL, RECOIL STARTER	D16	39	4		H6	93	7

PART NAME INDEX

J 4

Part name	Address	Page	Ref.	Part name	Address	Page	Ref.	Part name	Address	Page	Ref.
SEAL, MUFFLER PROTECTOR	H7	94	4	SWITCH ASSY., OIL LEVEL	D3	26	2				
SEAL, VALVE STEM	D12	35	1		D4	27	17				
SEPARATOR, AIR CLEANER	F1	56	2	SWITCH COMP., STARTING MAGNET ..	F16	71	2				
	H6	93	2								
SHAFT COMP., P.T.O.	G11	82	17	[T]							
SHAFT UNIT, GEAR	F16	71	7	TANK COMP., FUEL	F8	63	5				
SHAFT, GOVERNOR ARM	D3	26	5		F9	64	5				
SHAFT, P.T.O.	G10	81	5		F12	67	3				
	G13	84	5	THROTTLE ASSY., AUTO	G7	78	2				
SHROUD ASSY., UPPER	E5	44	18	TOOL KIT	H1	88	3				
SHROUD COMP.	E4	43	5	TUBE, BREATHER	D1	24	8				
SHROUD COMP., LOWER	E4	43	5								
SLIDER, GOVERNOR	D3	26	4	TUBE, DRAIN	H2	89	2				
SOLENOID ASSY., AUTO THROTTLE	G7	78	7	TUBE, FASTENER, 30MM	G9	80	19				
SPACER COMP., CARBURETOR	E9	48	15	TUBE, FUEL, 4.5X110	F10	65	14				
SPACER, 20MM	G10	81	8	TUBE, FUEL, 4.5X140	F10	65	15				
SPACER, CONTROL LEVER	G4	75	14	TUBE, FUEL, 4.5X145	F12	67	9				
SPACER, MUFFLER COVER	H9	96	5	TUBE, FUEL, 4.5X300	F10	65	15				
SPACER, RECOIL STARTER				TUBE, FUEL, 4.5X35	F10	65	13				
MOUNTING	D16	39	2	TUBE, FUEL, 4.5X430	F10	65	15				
SPANNER, 10X12	H1	88	4	[V]							
SPANNER, 14X17	H1	88	5	VALVE SET, FLOAT	E6	45	2				
SPRING, CABLE RETURN	G5	76	17		E13	52	2				
SPRING, CHOKE RETURN	G7	78	1	VALVE, EX.	D13	36	8				
SPRING, CLUTCH FREE	G11	82	10	VALVE, IN.	D12	35	7				
SPRING, COCK LEVER	E10	49	20	[W]							
SPRING, CONTROL ADJUSTING	E5	44	16	WASHER, 8MM	D7	30	7				
	G5	76	16		G10	81	9				
SPRING, FRICTION	E1	40	8	WASHER, CONTROL LEVER	G4	75	12				
SPRING, GOVERNOR	G4	75	7	WASHER, DRAIN PLUG, 10.2MM	D3	26	8				
	H2	89	3		H2	89	13				
SPRING, GOVERNOR ARM RETURN ..	G6	77	33	WASHER, DRAIN PLUG, 12MM	G11	82	25				
SPRING, LEVER	G4	75	11		G13	84	9				
SPRING, RECOIL STARTER	E1	40	9	WASHER, PINION	G1	72	26				
SPRING, RETURN	E2	41	10	WASHER, PLAIN, 4MM	G9	80	23				
	E11	50	30	WASHER, PLAIN, 5MM	H10	97	10				
	F16	71	13	WASHER, PLAIN, 6MM	D4	27	14				
SPRING, THROTTLE RETURN	G4	75	8	WASHER, SPECIAL	G2	73	30				
SPRING, THRUST	G10	81	7	WASHER, SPRING	G2	73	31				
SPRING, VALVE	D13	36	10	WASHER, SPRING, 4MM	G9	80	24				
SPRING, WEIGHT RETURN	D12	35	6	WASHER, SPRING, 8MM	G12	83	26				
SPROCKET COMP., DRIVE	G11	82	15	WASHER, THRUST, 14.1MM	D14	37	19				
SPROCKET, DRIVE	G10	81	4	WASHER, THRUST, 20MM	G11	82	18				
STARTER ASSY., RECOIL	D15	38	1	WASHER, THRUST, 6MM	D3	26	7				
	D16	39	1	WEIGHT, CLUTCH	G11	82	12				
STAY, AIR CLEANER	F1	56	4	WRENCH COMP., SPARK PLUG	H1	88	1				
	H6	93	4	WRENCH, BOX	H3	90	29				
STAY, CHOKE CONTROL	E11	50	28	WRENCH, SPARK PLUG	H1	88	1				
STAY, MUFFLER	F4	59	2	[Y]							
STRAINER COMP., FUEL	F8	63	3	YOKE ASSY.	F16	71	8				
STRAP, WIRE HARNESS, 25MM	G9	80	18								
SUB HARNESS	E5	44	20								
SUB HARNESS ASSY.	G7	78	6								
SUSPENSION, COUPLER	G8	79	6								
	H3	90	20								
SWITCH ASSY., COMBINATION	G8	79	10								
	H3	90	21								
SWITCH ASSY., ENGINE STOP	E4	43	7								
			8								

4

1

FOREWORD INDEX

2

ENGINE GROUP

3

PART NUMBER INDEX

4

PART NAME INDEX

HONDA
The Power of Dreams