

PARTS MANUAL



StreetPro SERIES MODEL SP118 PROFESSIONAL PAVEMENT SAW (HONDA GX390U1QWT2 GASOLINE ENGINE)

Revision #1 (07/29/10)

To find the latest revision of this
publication, visit our website at:
www.multiquip.com



THIS MANUAL MUST ACCOMPANY THE EQUIPMENT AT ALL TIMES.

PN: 38270

TABLE OF CONTENTS

SP118 Pavement Saw

Table Of Contents	2
Parts Ordering Procedures.....	3
Explanation Of Code In Remarks Column	4
Suggested Spare Parts	5
Nameplate And Decals.....	6-7
Console Frame Assembly.....	8-9
Platform Frame/Undercarriage Assembly.....	10-11
Raise/Lower Assembly.....	12-13
Lifting Bale Assembly.....	14-15
Pointer Assembly.....	16-17
Blade Spindle Assembly.....	18-19
Blade Guard Assembly.....	20-21
Engine Assembly.....	22-23
Belts And Tensioning Assembly.....	24-25
Belt Guard Assembly.....	26-27
Water System Assembly.....	28-29
Optional Water Tank Assembly.....	30-31

Honda GX390U1QWT2 Engine

Air Cleaner Assembly.....	32-33
Camshaft Assembly.....	34-35
Carburetor Assembly.....	36-37
Control Assembly.....	38-39
Crankcase Assembly.....	40-41
Crankshaft Assembly.....	42-43
Cylinder Barrell Assembly.....	44-45
Cylinder Head Assembly.....	46-47
Fan Cover Assembly.....	48-49
Flywheel Assembly.....	50-51
Fuel Tank Assembly.....	52-53
Ignition Coil Assembly.....	54-55
Muffler Assembly.....	56-57
Piston Assembly.....	58-59
Recoil Starter Assembly.....	60-61
Labels Assembly.....	62-63
Terms And Conditions Of Sale — Parts	64

NOTICE

Part numbers are subject to change without notice.

PARTS ORDERING PROCEDURES

Ordering parts has never been easier! Choose from three easy options:

Effective:
January 1st, 2006

www.multiquip.com



Order via Internet (Dealers Only):

Order parts on-line using Multiquip's SmartEquip website!

- View Parts Diagrams
- Order Parts
- Print Specification Information



If you have an MQ Account, to obtain a Username and Password, E-mail us at: parts@multiquip.com.

To obtain an MQ Account, contact your District Sales Manager for more information.

Goto www.multiquip.com and click on **Order Parts** to log in and save!

Use the **internet** and qualify for a **5% Discount** on *Standard orders* for all orders which include complete part numbers.*

Note: Discounts Are Subject To Change

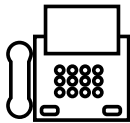

Order via Fax (Dealers Only):

All customers are welcome to order parts via Fax.

Domestic (US) Customers dial:
1-800-6-PARTS-7 (800-672-7877)

Fax your order in and qualify for a **2% Discount** on *Standard orders* for all orders which include complete part numbers.*

Note: Discounts Are Subject To Change



Order via Phone: Domestic (US) Dealers Call:
1-800-427-1244

Non-Dealer Customers:

Contact your local Multiquip Dealer for parts or call 800-427-1244 for help in locating a dealer near you.



International Customers should contact their local Multiquip Representatives for Parts Ordering information.

When ordering parts, please supply:

- | | |
|---|--|
| <input type="checkbox"/> Dealer Account Number | <input type="checkbox"/> Specify Preferred Method of Shipment: |
| <input type="checkbox"/> Dealer Name and Address | <input checked="" type="checkbox"/> UPS/Fed Ex <input checked="" type="checkbox"/> DHL |
| <input type="checkbox"/> Shipping Address (if different than billing address) | <input type="checkbox"/> Priority One <input checked="" type="checkbox"/> Truck |
| <input type="checkbox"/> Return Fax Number | <input type="checkbox"/> Ground |
| <input type="checkbox"/> Applicable Model Number | <input type="checkbox"/> Next Day |
| <input type="checkbox"/> Quantity, Part Number and Description of Each Part | <input type="checkbox"/> Second/Third Day |

NOTICE

All orders are treated as *Standard Orders* and will ship the same day if received prior to 3PM PST.

WE ACCEPT ALL MAJOR CREDIT CARDS!



EXPLANATION OF CODE IN REMARKS COLUMN

The following section explains the different symbols and remarks used in the Parts section of this manual. Use the help numbers found on the back page of the manual if there are any questions.

NOTICE

The contents and part numbers listed in the parts section are subject to change **without notice**. Multiquip does not guarantee the availability of the parts listed.

SAMPLE PARTS LIST

NO.	PART NO.	PART NAME	QTY.	REMARKS
1	12345	BOLT.....	1	INCLUDES ITEMS W/%
2%		WASHER, 1/4 IN.....		NOT SOLD SEPARATELY
2%	12347	WASHER, 3/8 IN....	1	MQ-45T ONLY
3	12348	HOSE	A/R	MAKE LOCALLY
4	12349	BEARING	1	S/N 2345B AND ABOVE

NO. Column

Unique Symbols — All items with same unique symbol

(@, #, +, %, or >) in the number column belong to the same assembly or kit, which is indicated by a note in the “Remarks” column.

Duplicate Item Numbers — Duplicate numbers indicate multiple part numbers, which are in effect for the same general item, such as different size saw blade guards in use or a part that has been updated on newer versions of the same machine.

NOTICE

When ordering a part that has more than one item number listed, check the remarks column for help in determining the proper part to order.

PART NO. Column

Numbers Used — Part numbers can be indicated by a number, a blank entry, or TBD.

TBD (To Be Determined) is generally used to show a part that has not been assigned a formal part number at the time of publication.

A blank entry generally indicates that the item is not sold separately or is not sold by Multiquip. Other entries will be clarified in the “Remarks” Column.

QTY. Column

Numbers Used — Item quantity can be indicated by a number, a blank entry, or A/R.

A/R (As Required) is generally used for hoses or other parts that are sold in bulk and cut to length.

A blank entry generally indicates that the item is not sold separately. Other entries will be clarified in the “Remarks” Column.

REMARKS Column

Some of the most common notes found in the “Remarks” Column are listed below. Other additional notes needed to describe the item can also be shown.

Assembly/Kit — All items on the parts list with the same unique symbol will be included when this item is purchased.

Indicated by:

“INCLUDES ITEMS W/(unique symbol)”

Serial Number Break — Used to list an effective serial number range where a particular part is used.

Indicated by:

“S/N XXXXX AND BELOW”

“S/N XXXX AND ABOVE”

“S/N XXXX TO S/N XXX”

Specific Model Number Use — Indicates that the part is used only with the specific model number or model number variant listed. It can also be used to show a part is NOT used on a specific model or model number variant.

Indicated by:

“XXXXX ONLY”

“NOT USED ON XXXX”

“Make/Obtain Locally” — Indicates that the part can be purchased at any hardware shop or made out of available items. Examples include battery cables, shims, and certain washers and nuts.

“Not Sold Separately” — Indicates that an item cannot be purchased as a separate item and is either part of an assembly/kit that can be purchased, or is not available for sale through Multiquip.

SUGGESTED SPARE PARTS

SP118 PROFESSIONAL PAVEMENT SAW WITH HONDA GX390U1QWT2 ENG.

1 to 3 units

Qty.	P/N	Description
3.....	20478.....	HAND GRIP
4.....	2621.....	GREASE ZERK, SPINDLE BEARING
4.....	1162 A	CAP, GREASE ZERK
3.....	13249.....	BELT (3VX315) 13HP HONDA
3.....	9807956846.....	SPARK PLUG, BPR6ES, NKG
1.....	17620Z0T305	TANK CAP, CHROME PLATED
2.....	17210ZE3010	AIR CLEANER ELEMENT
1.....	28462ZE3W01.....	ROPE, RECOIL STARTER
2.....	28086-001	8" REAR WHEEL
2.....	26221-001	4" FRONT WHEEL
1.....	29013-001	1-1/2" BOX WRENCH

NOTICE

Part numbers on this Suggested Spare Parts list may supersede/replace the part numbers shown in the following parts lists.

NAMEPLATE AND DECALS

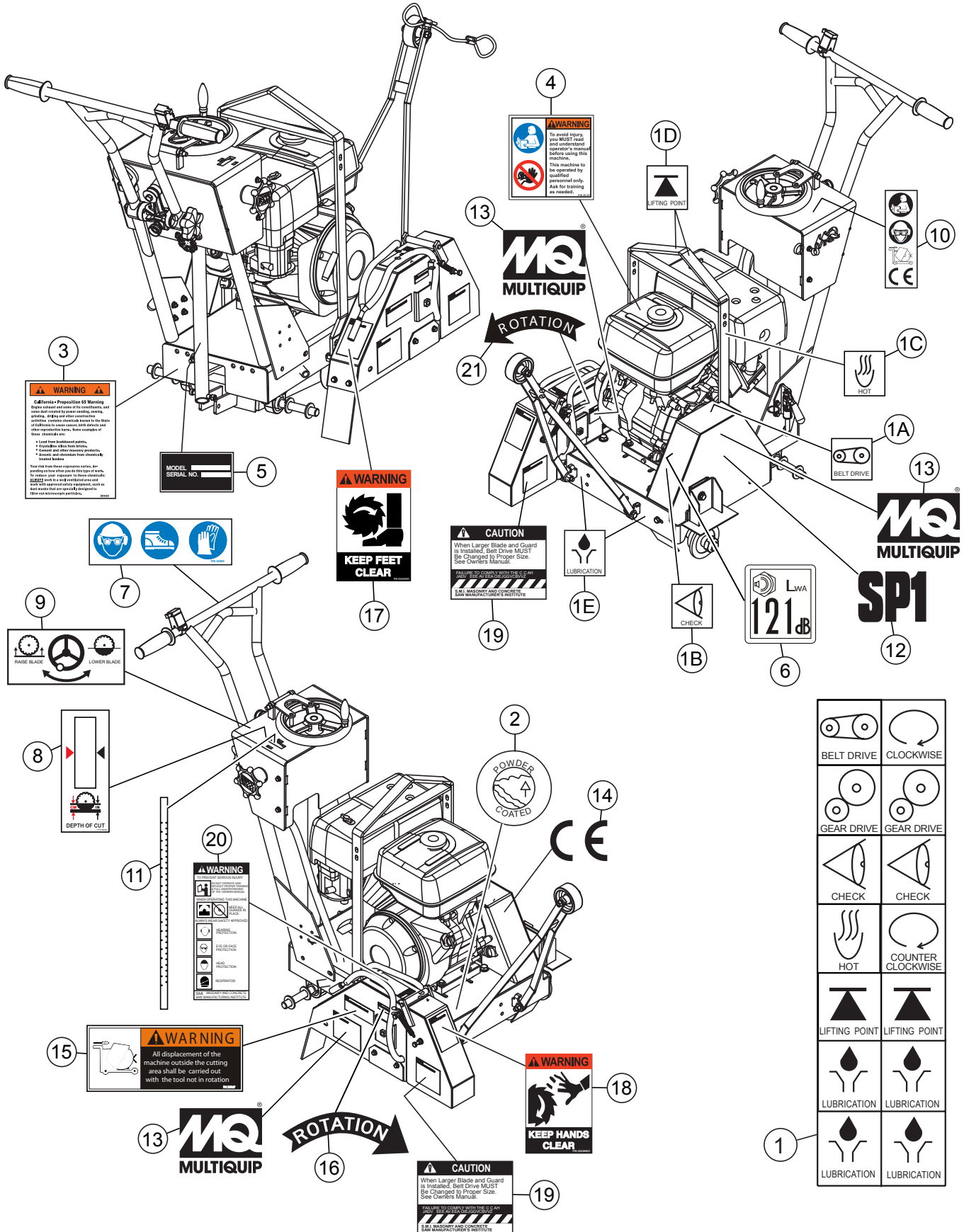

WARNING

California Proposition 65 Warning
 Some of the components of this equipment, and their parts, may contain or be derived from certain substances known to the State of California to cause cancer, birth defects, or other reproductive harm. Some examples of these substances are:

- Lead and lead compounds
- Crystalline silica from wear
- Formaldehyde and other respiratory irritants
- Benzene and chemicals from electrical equipment

Your risk from these exposures varies, depending on how often you use this type of equipment. To reduce your exposure to these chemicals, follow the instructions for safe use. For more information on these chemicals, go to www.cdph.ca.gov/ToxicSubstances/Pages/Prop65.aspx.

MODEL SERIAL NO. 5

WARNING

To avoid injury you MUST read and understand operator's manual before using this machine. This machine is to be operated only by qualified personnel only. Ask for training as needed.

WARNING

KEEP FEET CLEAR

CAUTION

When Larger Blade and Guard is Installed, Belt Drive MUST Be Changed to Proper Size. See Operator's Manual.

USE ONLY WITH THE CORRECT MASONRY AND CONCRETE.

LWA 121 dB

MQ
MULTIQUIP

SP1

BELT DRIVE	CLOCKWISE
GEAR DRIVE	GEAR DRIVE
CHECK	CHECK
HOT	COUNTER CLOCKWISE
LIFTING POINT	LIFTING POINT
LUBRICATION	LUBRICATION
LUBRICATION	LUBRICATION

NAMEPLATE AND DECALS

<u>NO.</u>	<u>PART NO.</u>	<u>PART NAME</u>	<u>QTY.</u>	<u>REMARKS</u>
1	11246	DECAL SET, INTERNATIONAL STDS.....	1.....	INCLUDES ITEMS W/#
1A#		DECAL, BELT DRIVE	1	
1B#		DECAL, CHECK OIL	2	
1C#		DECAL, HOT SURFACE	2	
1D#		DECAL, LIFT POINT	1	
1E#		DECAL, LUBRICATION	2	
1F#		DECAL, GEAR DRIVE	4	
1G#		DECAL, CLOCKWISE ROTATION	1	
1H#		DECAL, COUNTER-CLOCKWISE ROTATION	1	
2	13118	DECAL, POWDER COATED	1	
3	20525	DECAL, WARNING CA PROP 65	1	
4	35137	DECAL, READ MANUAL, ASK FOR TRAINING	1	
5		DECAL, MQ CE SERIAL PLATE.....	1.....	CONTACT UNIT SALES
6	35453	DECAL, GUARANTEED SOUND POWER 121DB	1	
7	36099	DECAL, SAFETY	1	
8	38208	DECAL, DEPTH INDICATOR DATUM	1	
9	38209	DECAL, RAISE/LOWER	1	
10	38210	DECAL, CE/SAFETY	1	
11	38211	DECAL, DEPTH INDICATOR CAM	1	
12	38212	DECAL, SP1, BLACK	1	
13	38213	DECAL, MQ MULTQUIP, BLACK	3	
14	38226	DECAL, CE, BLACK, 1.25 X 1.75	1	
15	25867	DECAL, ROTATION IN DISPLACE 1.80 X 4.25	2	
16	25491	DECAL, BLADE ROTATION, CW, .75 X 2.25	1	
17	25250-001	DECAL, BLADE WARNING, FEET	1	
18	25249-001	DECAL, BLADE WARNING, HANDS	1	
19	23330-001	DECAL, CAUTION "BELT DRIVE"	2	
20	22122-001	DECAL, CAUTION - RX-W	1	
21	25678	DECAL, BLADE ROTATION, CCW, .75 X 2.25	1	

CONSOLE FRAME ASSY.

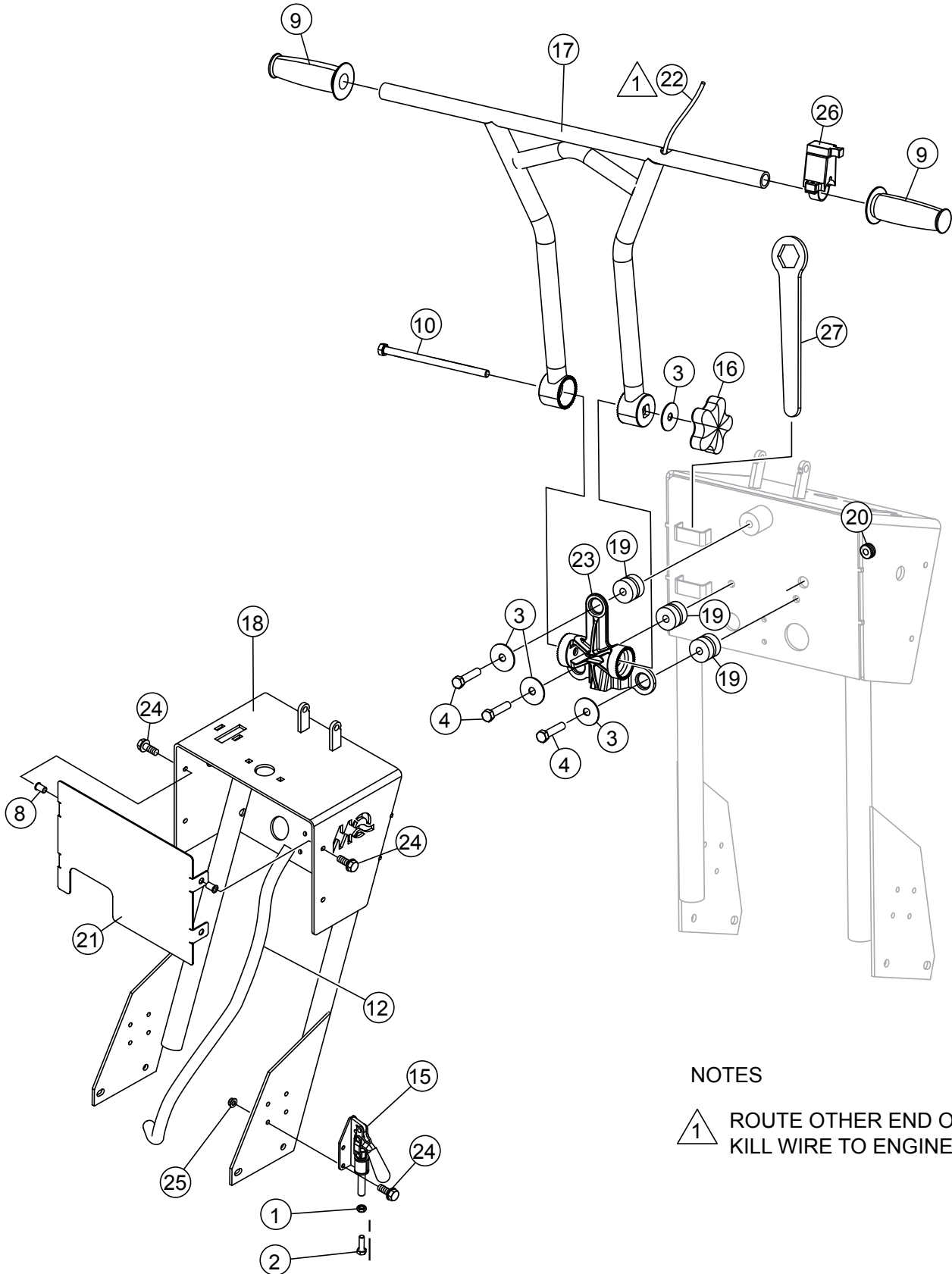

NOTES

- 1 ROUTE OTHER END OF KILL WIRE TO ENGINE

CONSOLE FRAME ASSY.

<u>NO.</u>	<u>PART NO.</u>	<u>PART NAME</u>	<u>QTY.</u>	<u>REMARKS</u>
1	0106	NUT, HEX JAM 5/16-18	1	
2	0202	SCREW, HHC 5/16-18 X 1 ZINC	1	
3	3233	WASHER, FENDER, 1.5OD X 3/8ID	4	
4	9154	SCREW, HHC 3/8-16 X 1-3/4	3	
8	19266	NUT, BLIND 1/4-20 X 10GA	4	
9	20478	GRIP, HANDLE	2	
10	22167	SCREW, HHC 3/8-16 X 6.5 GRADE 5	1	
14	35122-402	VALVE, GLOBE 1/2 FNPT BRASS	1	
15	35131	CLAMP, DESTACO MODEL 609	1	
16	37247	KNOB, DEPTH STOP CONTROL	1	
17	38148	HANDLE	1	
18	38157	CONSOLE FRAME.....	1.....	S/N WG0308946 AND BELOW
18	38377	CONSOLE FRAME.....	1.....	S/N WG0308947 AND ABOVE
19	38183	ISOLATOR, RUBBER DUROMETER RATING 60	3	
20	38191	GROMMET, RUBBER .375ID X .875OD	1	
21	38215	COVER, CONSOLE	1	
22	38218	HARNESS, KILL WIRE 70"	1	
23	38273	CHASSIS, ISOLATOR, GRAY	1	
24	49048	SCREW, HHFS 1/4-20 X 3/4 GR5	12	
25	49070	NUT, FLANGED 1/4-20 SERRATED	8	
26	35127	SWITCH, KILL MAGURA	1	
27	29013-001	WRENCH, BOX END 1-1/2	1	

PLATFORM FRAME/UNDERCARRIAGE ASSY.

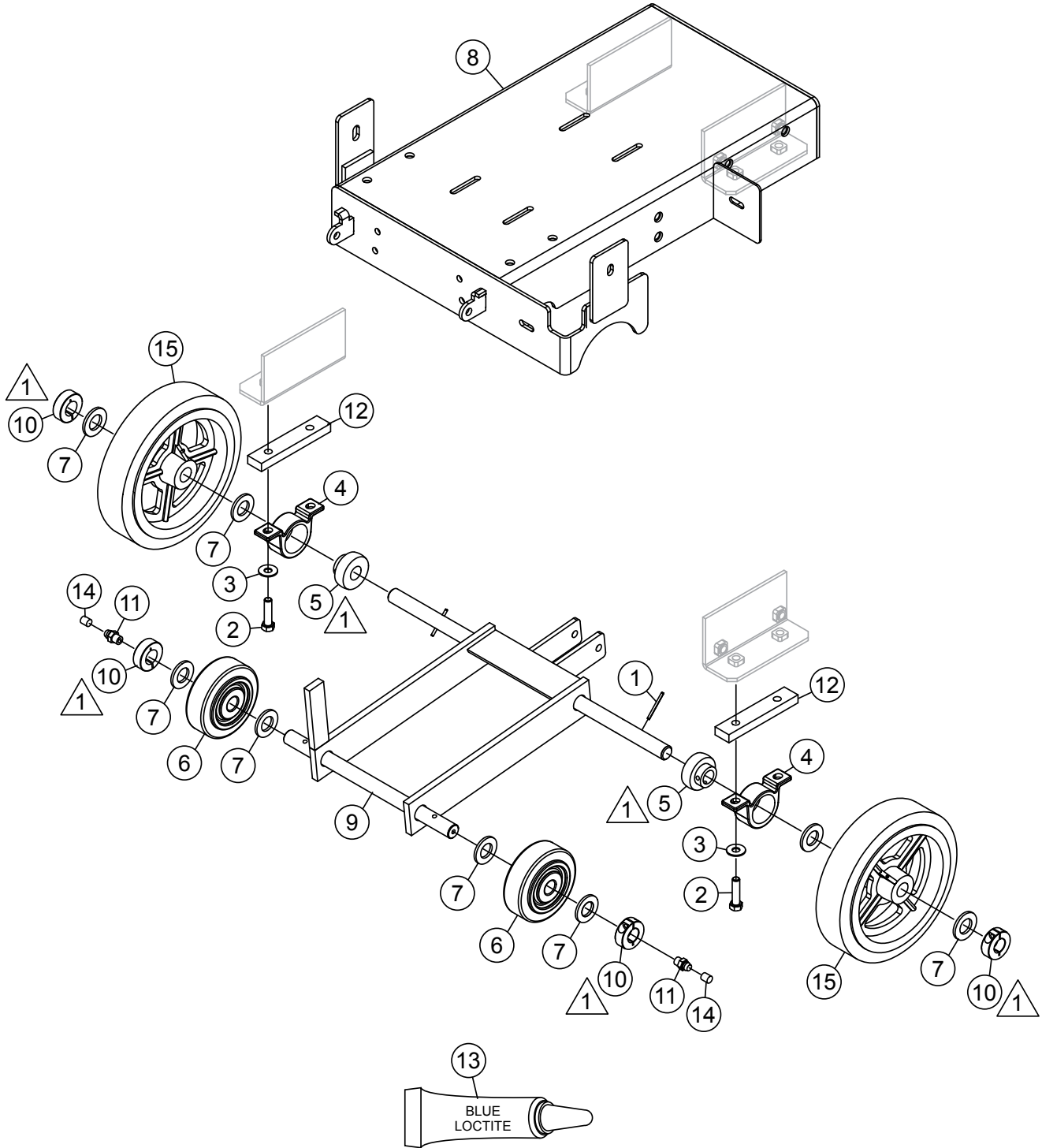

NOTES:

- 1 APPLY LOCTITE® BLUE 242 TO LOCKING COLLARS AND BEARINGS

PLATFORM FRAME/UNDERCARRIAGE ASSY.

<u>NO.</u>	<u>PART NO.</u>	<u>PART NAME</u>	<u>QTY.</u>	<u>REMARKS</u>
1	07402-024	PIN, ROLL 1/8 X 1-1/2 PLATED	2	
2	1284	SCREW, HHC 3/8-16 X 1-1/2	4	
3	10136	WASHER, FLAT SAE 3/8	4	
4	11138	HOUSING, P-BLOCK BEARING	2	
5	11149	BEARING, BALL SB-204-12	2	
6	26121-001	WHEEL, FRONT 4 X 1.5	2	
7	8151	WASHER, FLAT SAE 3/4	8	
8	38172	CHASSIS FRAME	1	
9	38194	WHEEL BASE	1	
10	25181-001	COLLAR, LOCKING	4	
11	2621	FITTING, GREASE ZERK STR 1/4-28	2	
12	25677	SPACER, REAR AXLE BEARING C 1 18"	2	
13	60091	LOCTITE #242, BLUE	1	
14	1162 A	CAP, GREASE ZERK	2	
15	28086-001	WHEEL, 8 X 2 X .75 ROLLER BEARING REAR	2	

RAISE/LOWER ASSY.

OLD STYLE
RAISE/LOWER ASSY.
(S/N WG0308946 AND BELOW)

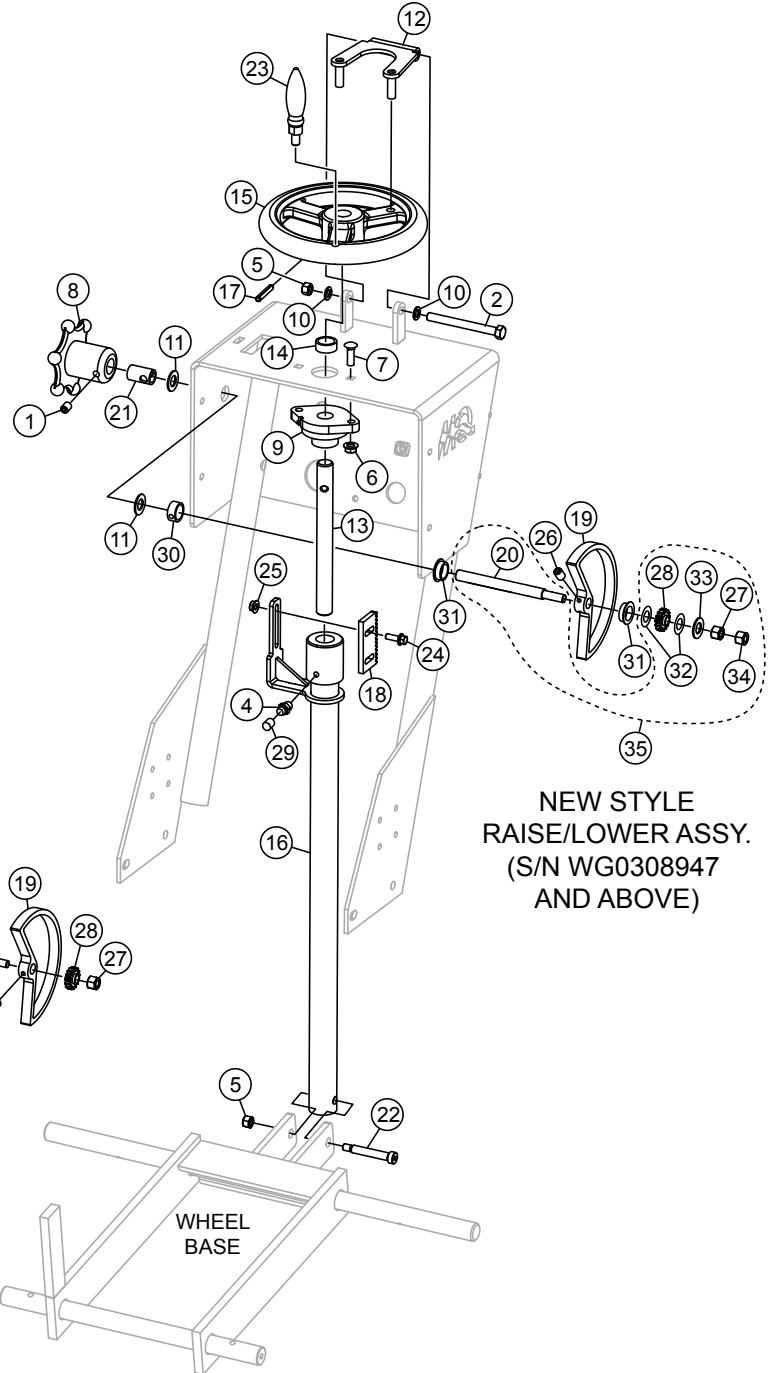
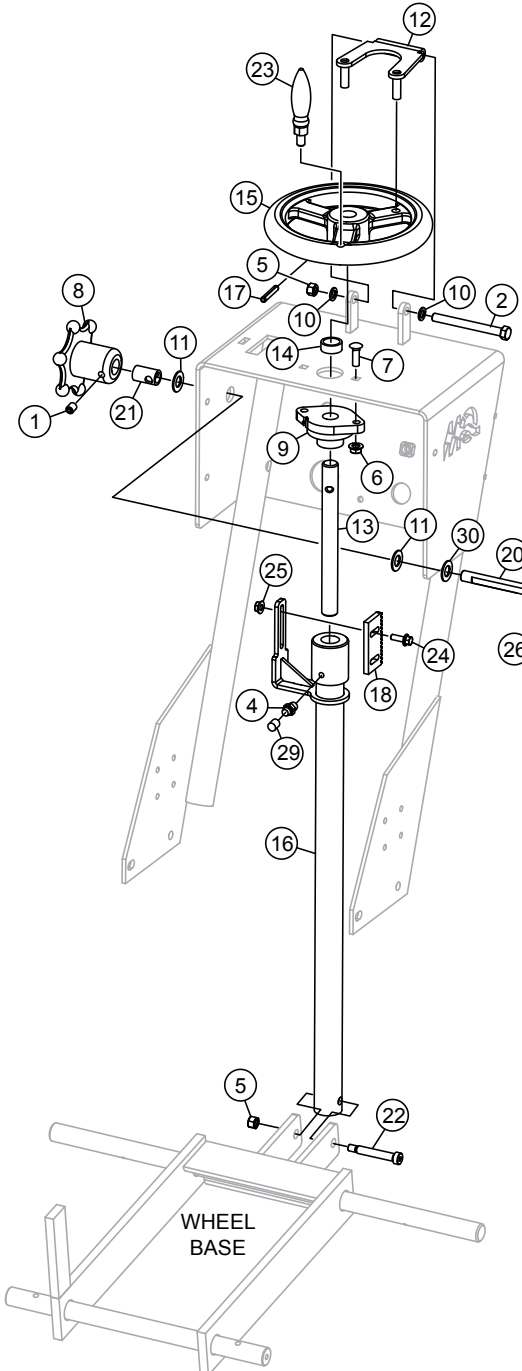

NEW STYLE
RAISE/LOWER ASSY.
(S/N WG0308947
AND ABOVE)

RAISE/LOWER ASSY.

<u>NO.</u>	<u>PART NO.</u>	<u>PART NAME</u>	<u>QTY.</u>	<u>REMARKS</u>
1	0122 C	SCREW, SHS 3/8-16 X 1/2	1	
2	1570	SCREW, HHC 3/8-16 X 3.75	1	
4	2621	FITTING, GREASE ZERK STR 1/4-28	1	
5	5283	NUT, NYLOC 5/16-18	2	
6	49071	NUT, FLANGED 5/16-18 SERRATED	2	
7	11963	BOLT, CARRAIGE 5/16-18 X 1	2	
8	20817	WHEEL, HAND	1	
9	23284-001	BEARING, FLANGE .34 SQ. X 3/4 BORE	1	
10	35235	WASHER, NYLON 3/8ID X .06OD	2	
11	36128	WASHER, NYLON 1/2 ID	2	
12	38161	RAISE/LOWER STOP	1	
13	38163	ACME ROD, 3/4-6 THREAD	1	
14	38164	SPACER, 1.0OD X .79ID X .25L	1	
15	38165	HANDWHEEL, 8" DIAMETER	1	
16	38167	RAISE/LOWER ASSY.	1	
17	38168	PIN, SPRING SLOTTED .250 X 2.00	1	
18	38176	GEAR RACK	1	
19	38177	CAM, 5.75" DIAMETER	1	S/N WG0308946 AND BELOW
19%	38372	CAM, DEPTH INDICATOR.....	1	S/N WG0308947 AND ABOVE
20	38179	SHAFT, STEPPED .500D X 5.707 L.....	1	S/N WG0308946 AND BELOW
20%	38371	SHAFT, DEPTH INDICATOR	1	S/N WG0308947 AND ABOVE
21	38180	SHIM, .730D X 1.180L	1	
22	38195	SCREW, SHLD .375D X 2.00L 1/4-20 SHC	1	
23	38219	HANDLE, HAND WHEEL	1	
24	49048	SCREW, HHFS 1/4-20 X 3/4 GR5	2	
25	49070	NUT, FLANGED 1/4-20 SERRATED PLTD	2	
26	925381	SCREW, SET 1/4-20 X 3/8	1	S/N WG0308946 AND BELOW
26	925381	SCREW, SET 1/4-20 X 3/8	2	S/N WG0308947 AND ABOVE
27	10133	NUT, NYLOC 3/8-16.....	1	S/N WG0308946 AND BELOW
27%	0161 D	NUT, HEX FINISH 5/16-18.....	1	S/N WG0308947 AND ABOVE
28	38214	PINION/BUSHING ASSY.....	1	S/N WG0308946 AND BELOW
28	38370	GEAR, DEPTH INDICATOR SPUR.....	1	S/N WG0308947 AND ABOVE
29	1162 A	CAP, GREASE ZERK	1	
30	1577	COLLAR	1	
31	38368	BUSHING, SPLIT FLANGED, .5 ID	2	S/N WG0308947 AND ABOVE
32%	38369	WASHER, BELLVILLE, .625 X .317 X .022.....	2	S/N WG0308947 AND ABOVE
33%	0300 B	WASHER, FLAT SAE 5/16	1	S/N WG0308947 AND ABOVE
34%	5283	NUT, NYLOC 5/16-18.....	1	S/N WG0308947 AND ABOVE
35	38376	GEAR/SHAFT ASSY	1	INCLUDES ITEMS W/%

LIFTING BALE ASSY.

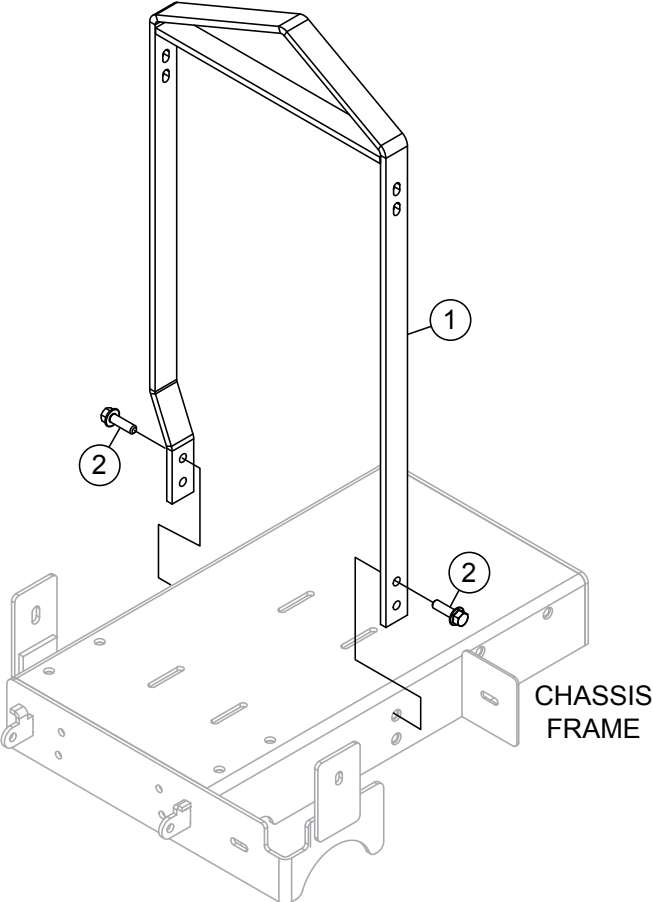

LIFTING BALE ASSY.

<u>NO.</u>	<u>PART NO.</u>	<u>PART NAME</u>	<u>QTY.</u>	<u>REMARKS</u>
1	38200	BALE, LIFTING	1	
2	22106	SCREW, HHFS 3/8-16 X 1.25 ZINC	4	

POINTER ASSY.

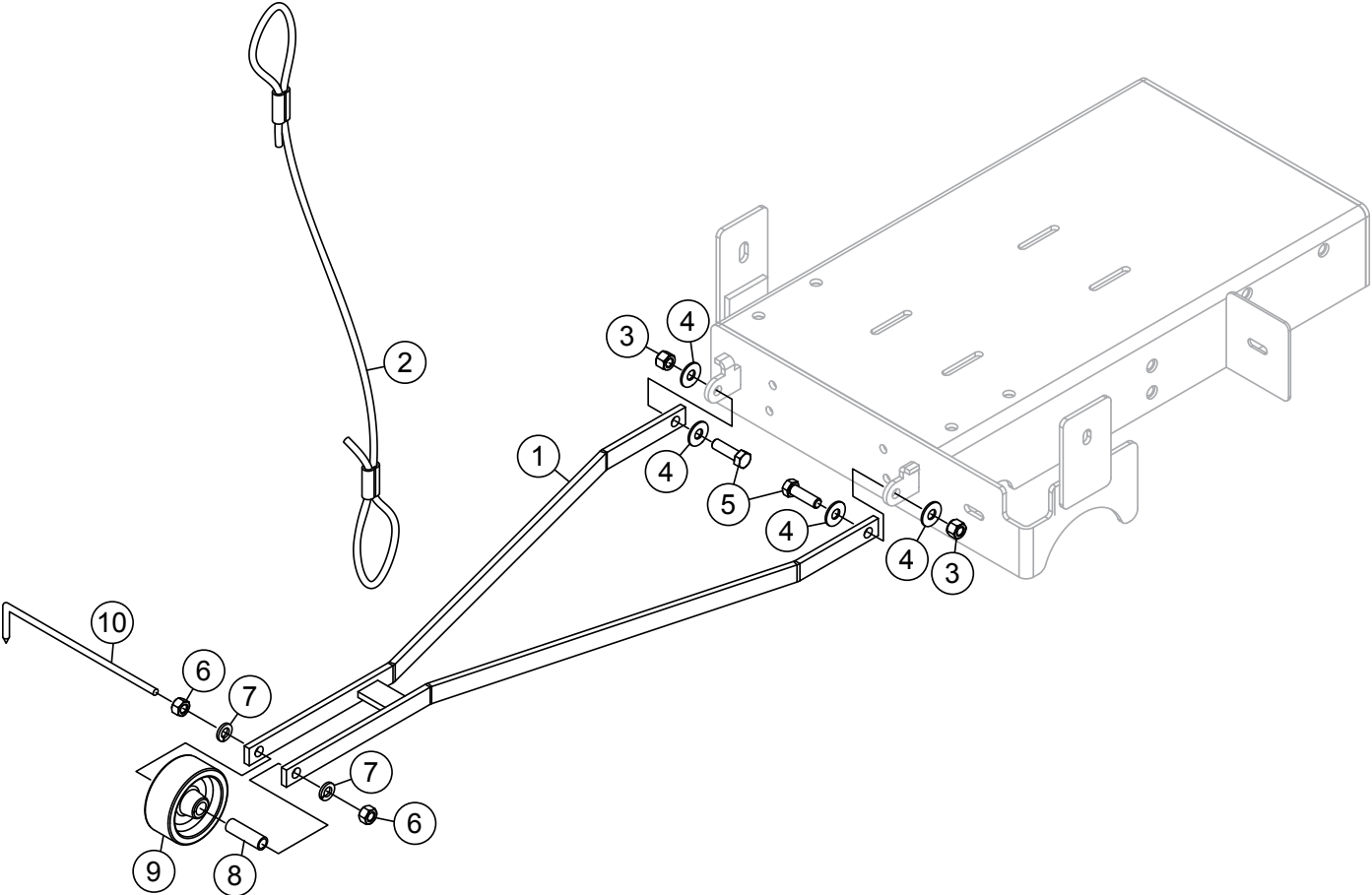

POINTER ASSY.

<u>NO.</u>	<u>PART NO.</u>	<u>PART NAME</u>	<u>QTY.</u>	<u>REMARKS</u>
1	28646-351	BLADE GUIDE WELDMENT	1	
2	15830	SASH ASSY, POINTER, 6-1/2'	1	
3	10133	NUT, NYLOC 3/8-16	2	
4	EM923025	WASHER FLAT 3/8 SAE	4	
5	1023	SCREW, HHC 3/8-16 X 1-1/4 GR 5	2	
6	1456	NUT, HEX FINISH 3/8-16	2	
7	0166 A	WASHER, LOCK 3/8 MED	2	
8	28649-001	SPANNER BUSHING CSI	1	
9	28648-001	WHEEL, 3 X 1.25 X .5 ID POLY CSI	1	
10	28647-001	POINTER	1	

BLADE SPINDLE ASSY.

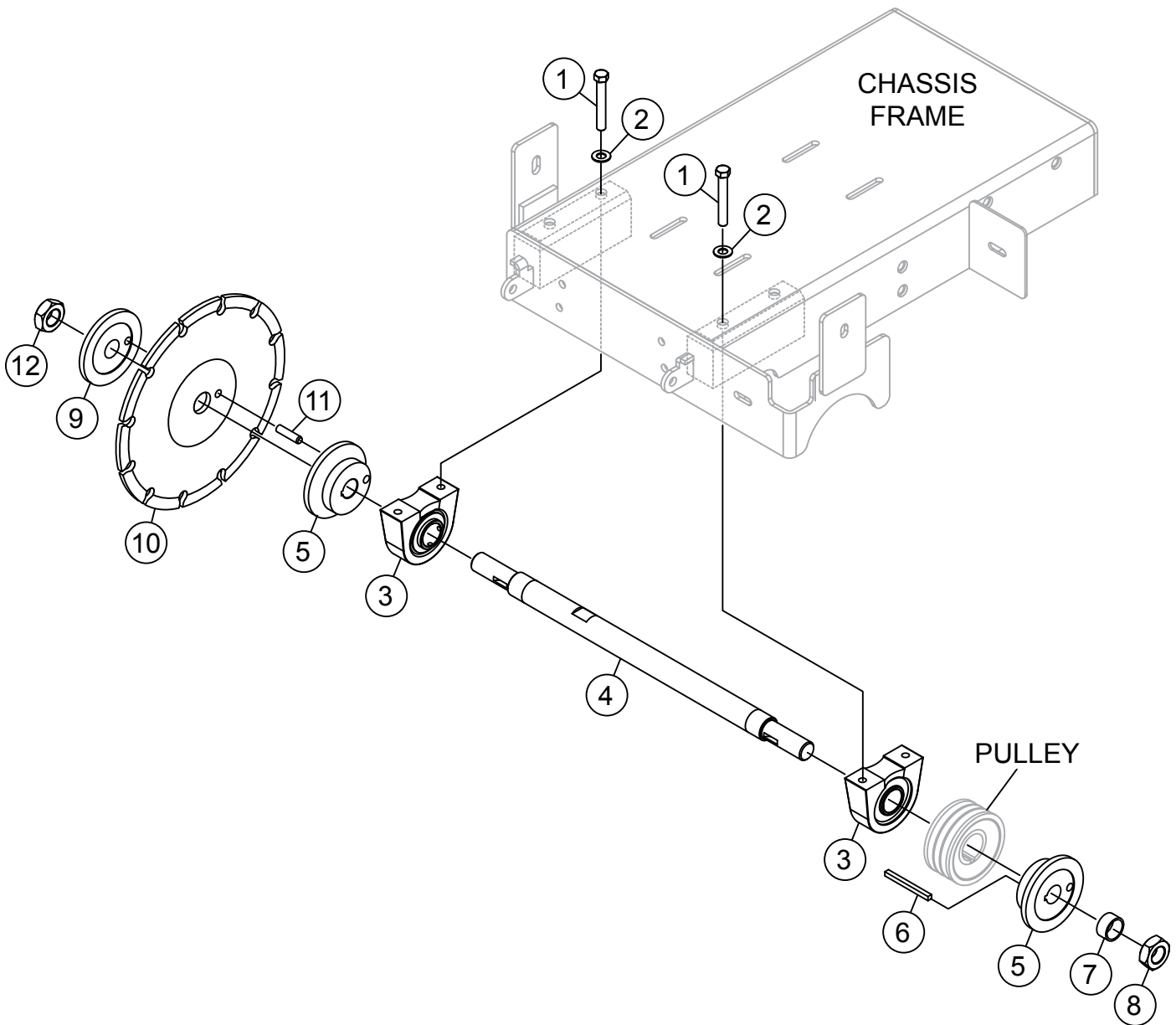

BLADE SPINDLE ASSY.

<u>NO.</u>	<u>PART NO.</u>	<u>PART NAME</u>	<u>QTY.</u>	<u>REMARKS</u>
1	915165	SCREW, HHC 7/16-14 X 3	4	
2	0448	WASHER, FLAT SAE 7/16	4	
3	28081-001	BEARING, PILLOW BLOCK	2	
4	28807-002	SPINDLE, BLADE	1	
5	28811-001	FLANGE, BLADE INNER	2	
6	38205	KEY, 1/4 SQUARE X 3	1	
7	38248	SPACER, 1.25 X 1 X .5	1	
8	07038-016	NUT, HEX JAM 1" -14 PLATED	1	
9	26928-004	FLANGE, BLADE OUTER	1	
10	TBD	BLADE	1	
11	24894-024	PIN, DOWEL 3/8 X 1-1/2 NO PLATE	1	
12	06922-003	NUT, HEX JAM LH SIDE 1-14 PLATED	1	

BLADE GUARD ASSY.

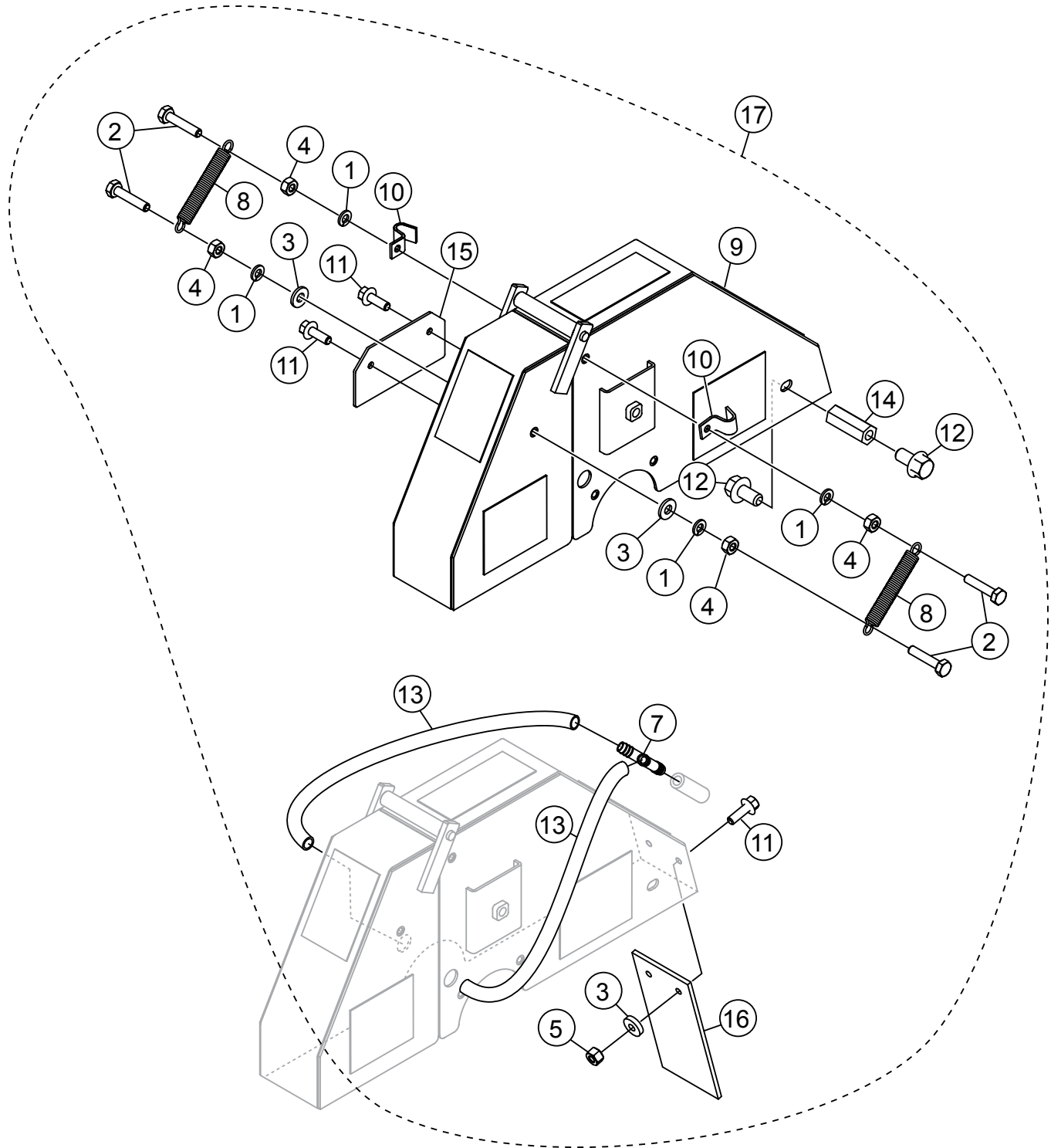

BLADE GUARD ASSY.

<u>NO.</u>	<u>PART NO.</u>	<u>PART NAME</u>	<u>QTY.</u>	<u>REMARKS</u>
1	0181 B	WASHER, LOCK 1/4 MED	4	
2	0424	SCREW, HHC 1/4-20 X 1-1/4	4	
3	0948	WASHER, FLAT SAE 1/4	4	
4	0949	NUT, HEX FINISH 1/4-20	4	
5	10024	NUT, NYLOC 1/4-20	2	
7	14233-004	FITTING, PLASTIC Y, 3/8 BARB USP 64016	1	
8	18626-001	SPRING, TENSION - GUARD BLADE	2	
9	29406-353	BLADE GUARD, 18" BARE	1	
10	22129-001	PIPE STRAP 3/8	2	
11	49048	SCREW, HHFS 1/4-20 X 3/4 GR5	4	
12	38274	SCREW, HHFS 3/8-16 X .75 ZINC	2	
13	60021	HOSE, 38ID X 5/8OD BRAIDED PVC "PAC"	2.5	SOLD IN FT. LENGTHS
14	29978-001	POST SUPPORT	2	
15	38247	COVER, BLADE GUARD CUTOUT	1	
16	28729-005	SPLASH GUARD	1	
17	38216	BLADE GUARD ASSY. 18"	1	

ENGINE ASSY.

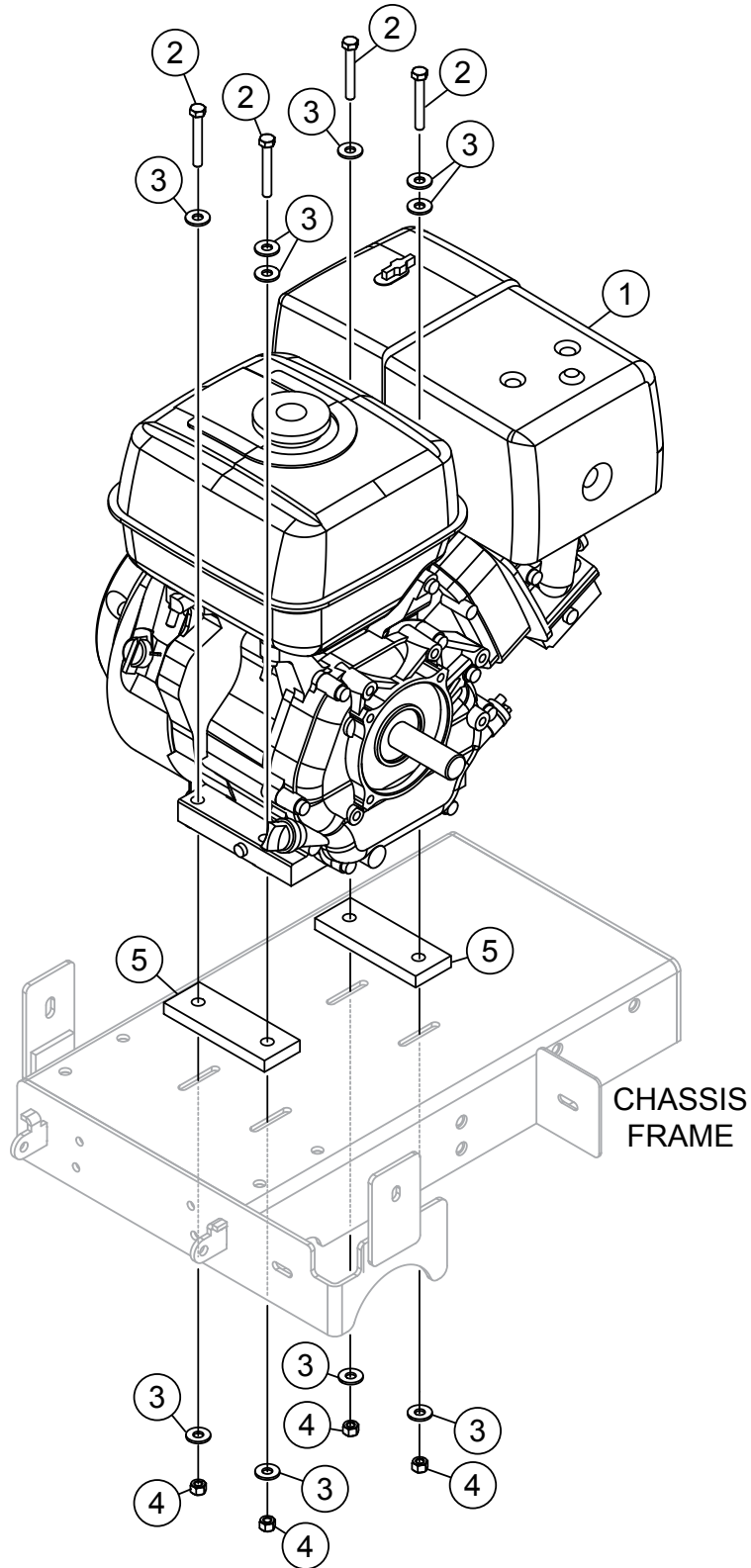

ENGINE ASSY.

<u>NO.</u>	<u>PART NO.</u>	<u>PART NAME</u>	<u>QTY.</u>	<u>REMARKS</u>
1	15103	ENGINE, HONDA 13HP GX390UQWT2	1	
2	0669 A	SCREW, HHC 5/16-18 X 2-1/4	4.....	SN XL0308587 AND BELOW
2	1207	SCREW, HHC 5/16-18 X 1-3/4	4.....	SN XL0308588 AND ABOVE
3	19470	WASHER, FLAT USS 5/16	10	
4	5283	NUT, NYLOC 5/16-18	4	
5	27044-001	SPACER, 3/8.....	2.....	SN XL0308587 AND BELOW

BELTS AND TENSIONING ASSY.

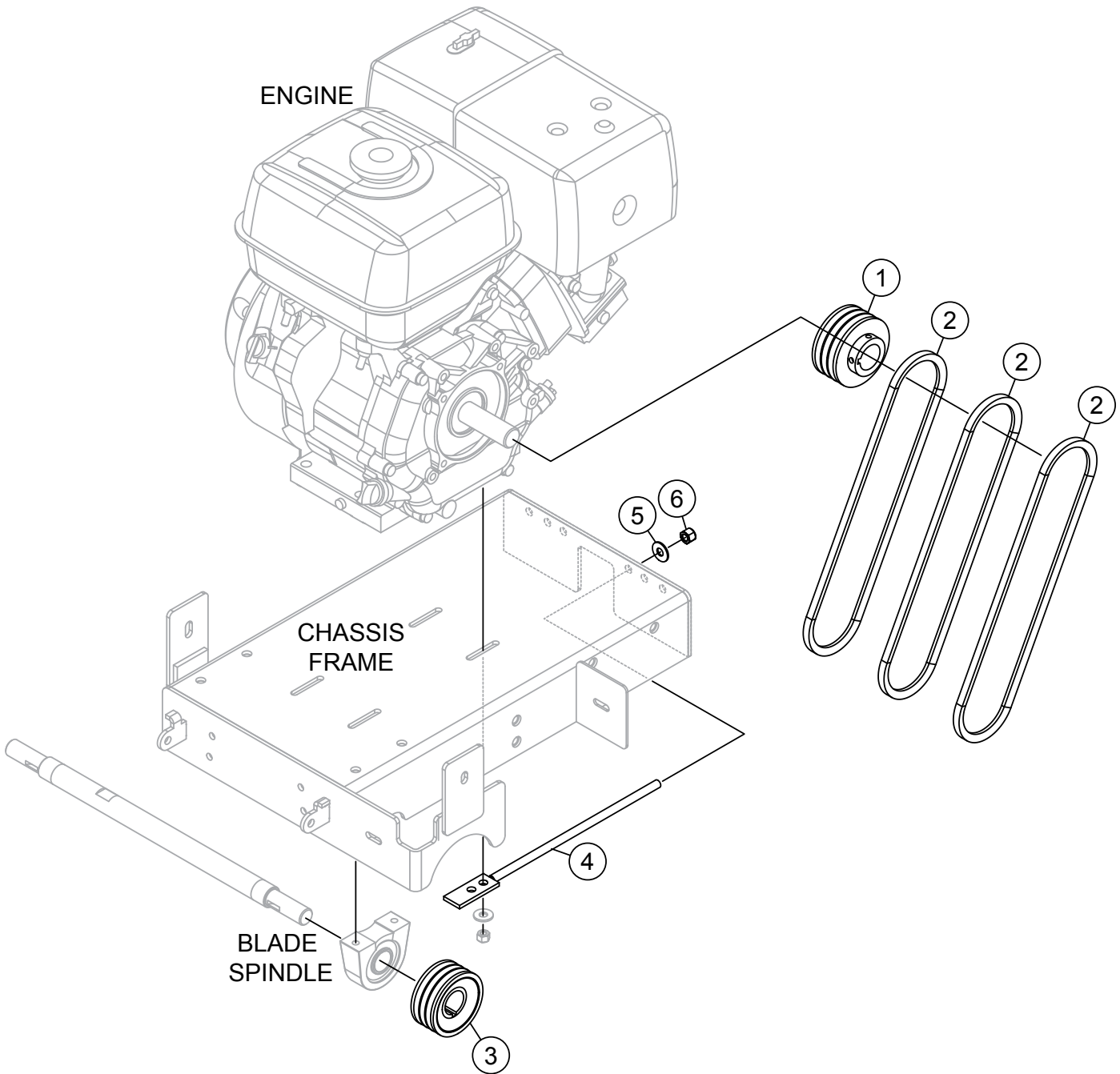

BELTS AND TENSIONING ASSY.

<u>NO.</u>	<u>PART NO.</u>	<u>PART NAME</u>	<u>QTY.</u>	<u>REMARKS</u>
1	23665-001	PULLEY, 3F3V26 X 1	2	
2	13249	BELT, 3VX315	3.....	SN XL0308587 AND BELOW
2	16779-006	BELT, 3VX300	3.....	SN XL0308588 AND ABOVE
3	25172-003	PULLEY, 3F3V33 X 1.25	1	
4	23811-352	BELT TIGHTENER	1	
5	EM923025	WASHER, FLAT 3/8 SAE	1	
6	10133	NUT, NYLOC 3/8-16	1	

BELT GUARD ASSY.

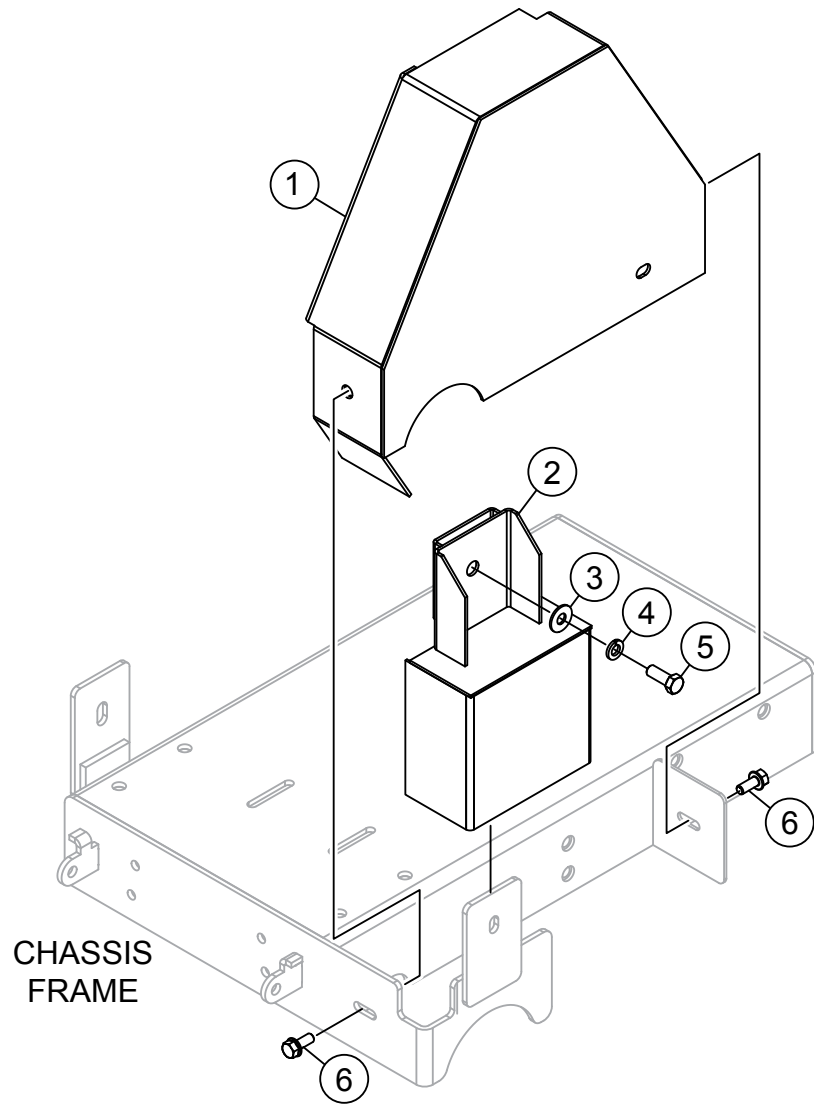

BELT GUARD ASSY.

<u>NO.</u>	<u>PART NO.</u>	<u>PART NAME</u>	<u>QTY.</u>	<u>REMARKS</u>
1	38185	BELT GUARD	1	
2	29745-354	SPINDLE GUARD	1	
3	EM923025	WASHER FLAT 3/8 SAE	1	
4	0166 A	WASHER, LOCK 3/8 MED	1	
5	0205	SCREW, HHC 3/8-16 X 1	1	
6	36720	SCREW, HHFS 5/16-18 X 3/4 GR5	2	

WATER SYSTEM ASSY.

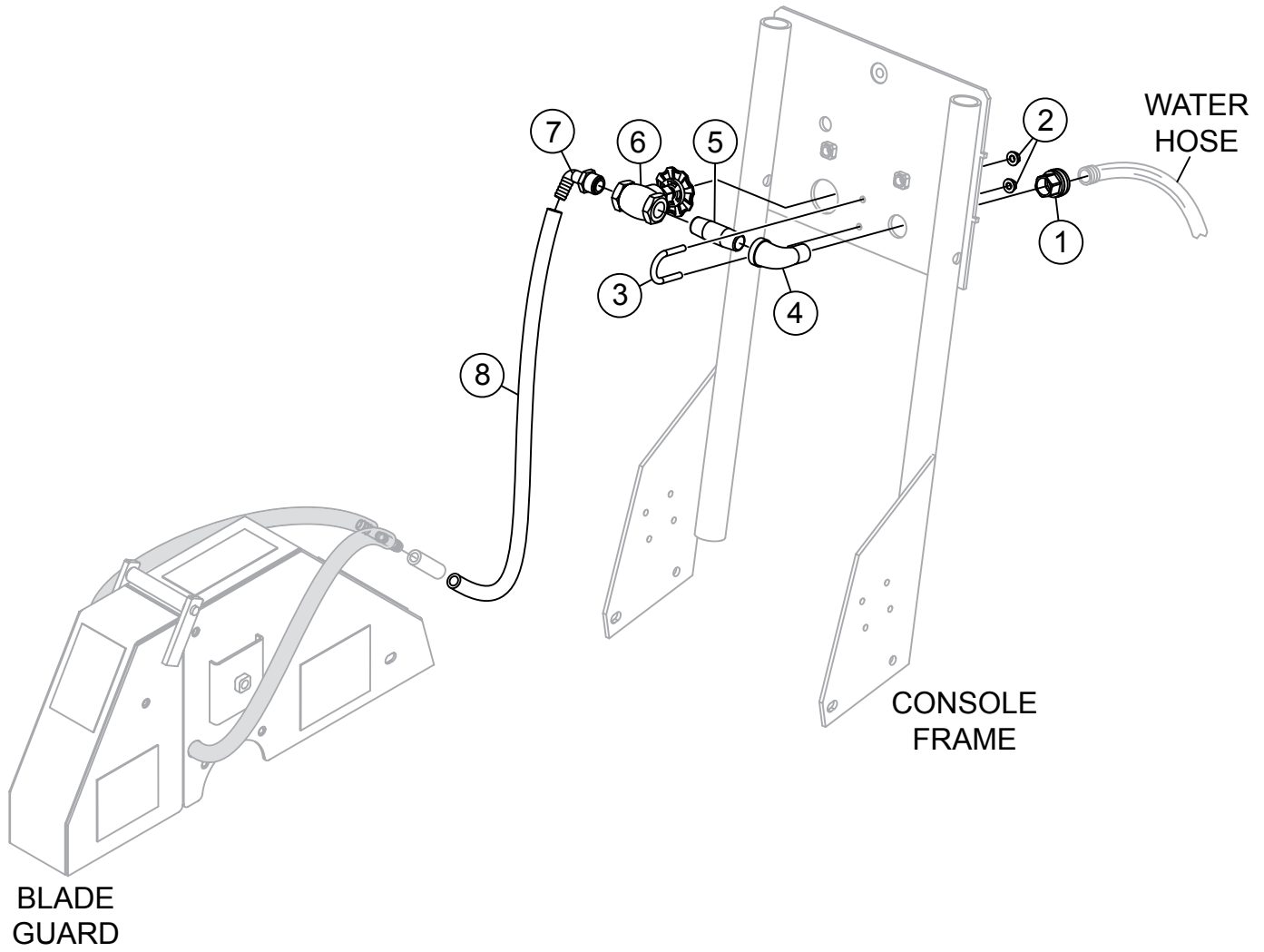

WATER SYSTEM ASSY.

<u>NO.</u>	<u>PART NO.</u>	<u>PART NAME</u>	<u>QTY.</u>	<u>REMARKS</u>
1	15544	FITTING, BRASS 1/2FP - 3/4F GRDN, STR	1	
2	49070	NUT, FLANGED 1/4-20 SERRATED PLTD	2	
3	16378-005	U-BOLT, 1/4-20 THREAD	1	
4	23252-002	FITTING, 90, STREET 1/2FP - 1/2MP GALV	1	
5	11708	FITTING, NIPPLE 1/2MP X 2.5	1	
6	35122-402	VALVE, GLOBE 1/2 FNPT BRASS	1	
7	23566-001	VALVE, PLASTIC 90 1/2MP X 1/2 BARB	1	
8	23255-011	HOSE, WATER 1/2 X 26" BRAID PVC	1	

OPTIONAL WATER TANK ASSY.

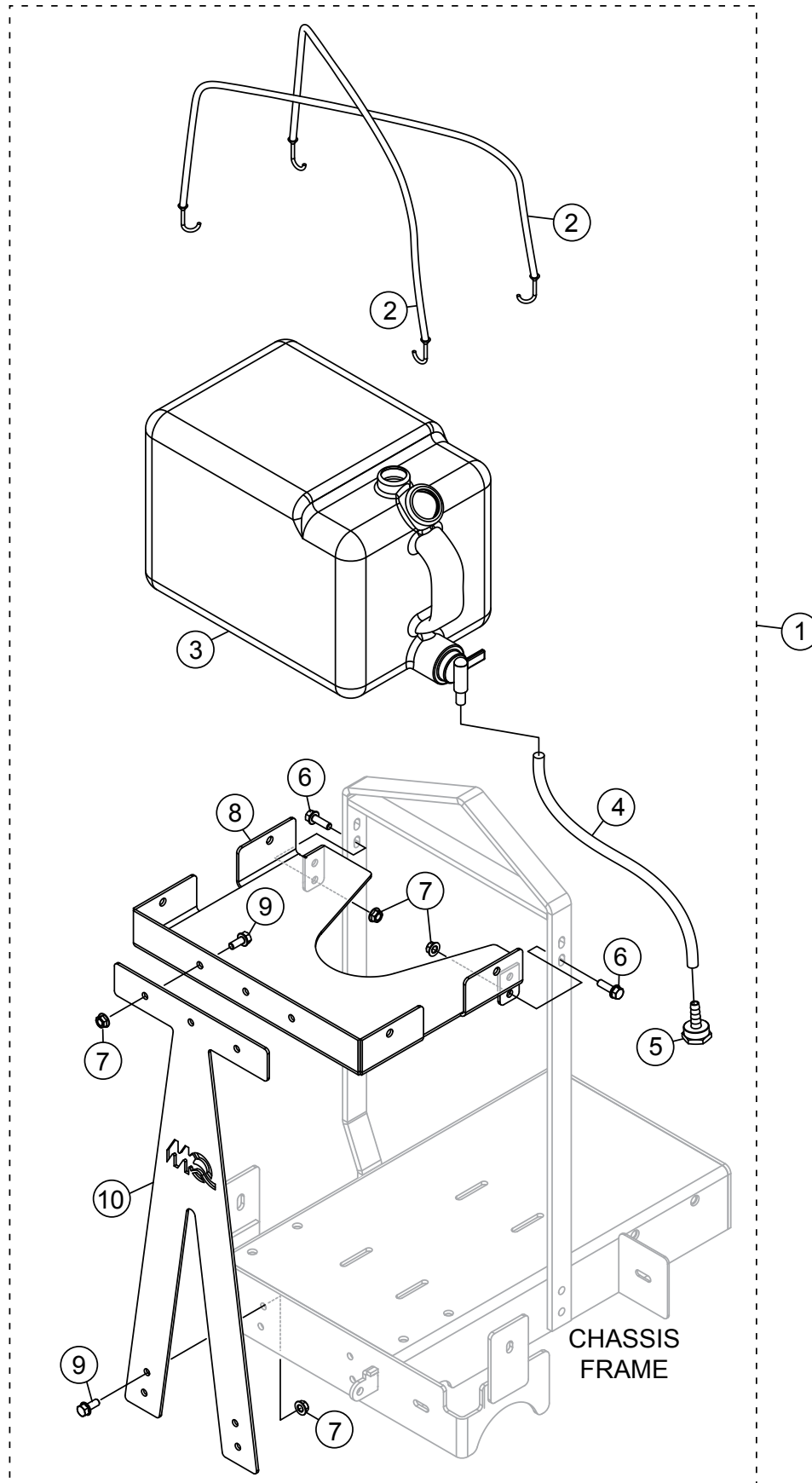

OPTIONAL WATER TANK ASSY.

<u>NO.</u>	<u>PART NO.</u>	<u>PART NAME</u>	<u>QTY.</u>	<u>REMARKS</u>
1	SP1WK	WATER TANK ASSY.....	1.....	INCLUDES ITEMS W/@
2@	38255	CORD, 3/8" X 20", BUNGEE	2	
3@	28089-001	TANK, WATER, WITH SPIGOT VALVE	1	
4@	60002	HOSE, PVC CLEAR .375 DIA X .5 DIA	1	
5@	24778-003	FITTING, BRASS 3/8 BARB X 3/4F GRDN	1	
6@	9091	SCREW, HHFS 5/16-18 X 1 GR5	4	
7@	49071	NUT, FLANGED 5/16-18 SERRATED PLTD	11	
8@	38252	BRACKET, 5 GAL WATER TANK	1	
9@	36720	SCREW, HHFS 5/16-18 X 3/4 GR5	7	
10@	38253	SUPPORT, WATER TANK BRACKET	1	

HONDA GX390U1QWT2 ENG. — AIR CLEANER ASSY.

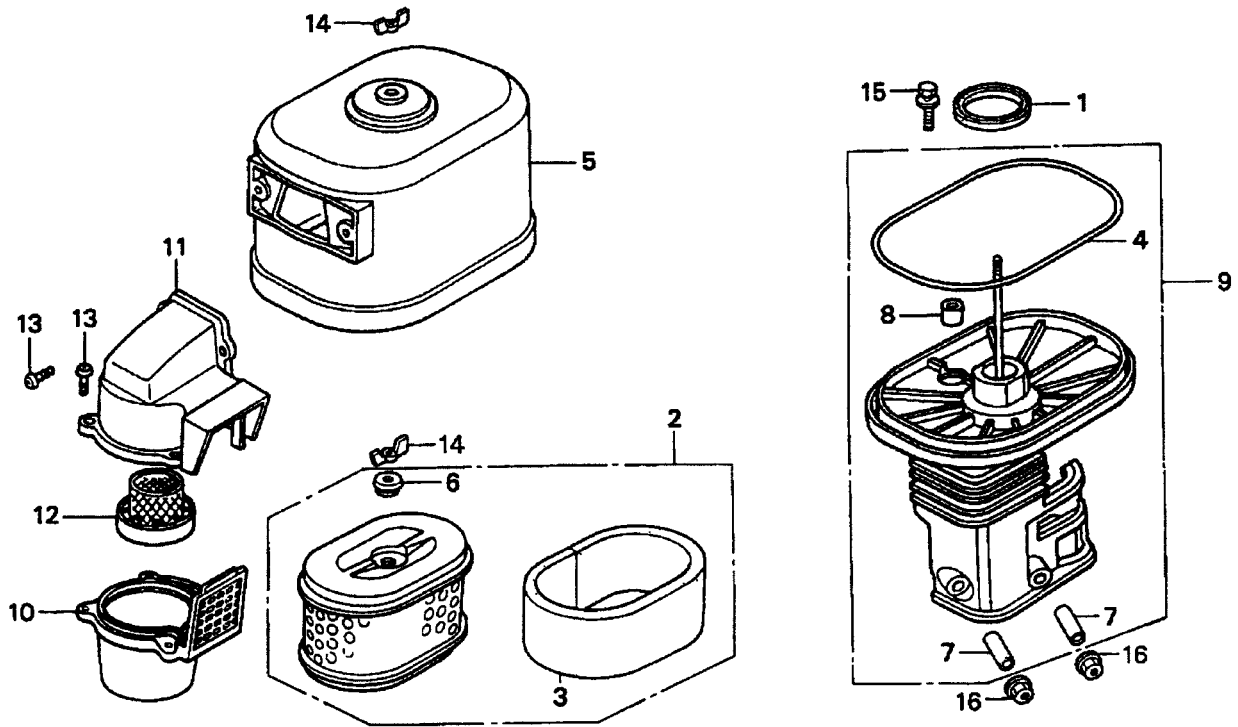

HONDA GX390U1QWT2 ENG. — AIR CLEANER ASSY.

<u>NO.</u>	<u>PART NO.</u>	<u>PART NAME</u>	<u>QTY.</u>	<u>REMARKS</u>
1	16271ZE2010	GASKET, ELBOW	1	
2	17210ZE3010	ELEMENT, AIR CLEANER	1	INCLUDES ITEMS W/@
3@	17218ZE3000	FILTER, OUTER	1	
4#	17219ZE3840	SEAL, AIR CLEANER COVER	1	
5	17230ZE3841	COVER, AIR CLEANER (CYCLONE)	1	
6@	17232891000	GROMMET, AIR CLEANER	1	
7#	17238ZE2310	COLLAR, AIR CLEANER	2	
8#	17239ZE3840	COLLAR B, AIR CLEANER	1	
9	17410ZE3840	ELBOW, AIR CLEANER	1	INCLUDES ITEMS W/#
10	17470ZE3842	CASE, PRE AIR CLEANER	1	
11	17475ZE3841	CAP, PRE AIR CLEANER	1	
12	17476ZE3841	GUIDE, PRE AIR CLEANER	1	
13	90142MB0000	SCREW, PAN 5X16.5	5	
14	90325044000	WINGNUT, TOOL BOX SETTING	2	
15	90009ZE2003	BOLT- WASHER 6X22	1	
16	9405006000	NUT, FLANGE 6MM	21	

HONDA GX390U1QWT2 ENG. — CAMSHAFT ASSY.

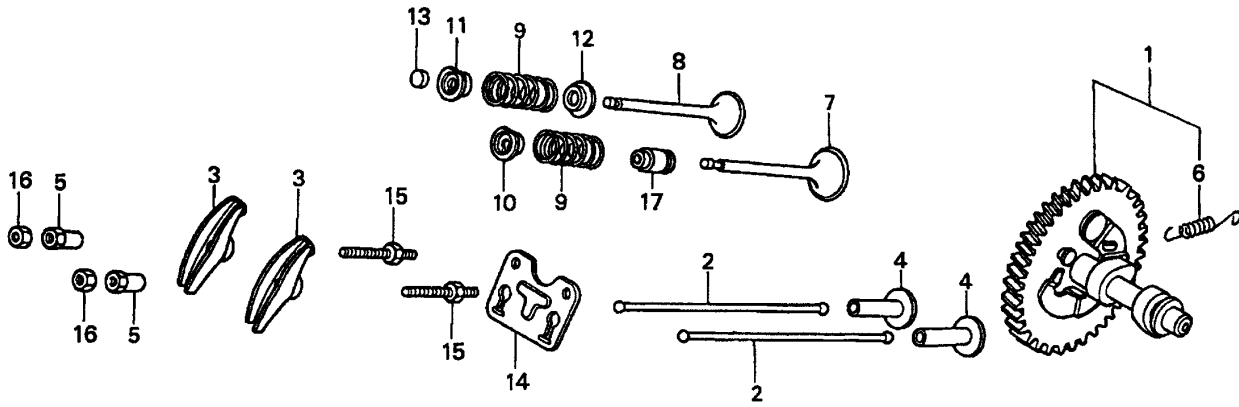

HONDA GX390U1QWT2 ENG. — CAMSHAFT ASSY.

<u>NO.</u>	<u>PART NO.</u>	<u>PART NAME</u>	<u>QTY.</u>	<u>REMARKS</u>
1	14100ZF6W01	CAMSHAFT ASSEMBLY	1.....	INCLUDES ITEM W/@
2	14410ZE3013	ROD, PUSH	2	
3	14431ZE2010	ARM, VALVE ROCKER	2	
4	14441ZE2000	LIFTER, VALVE	2	
5	14451ZE1013	PIVOT, ROCKER ARM	2	
6@	14568ZE1000	SPRING, WEIGHT RETURN	1	
7	14711ZE3000	VALVE, INTAKE	1	
8	14721ZE3000	VALVE, EXHAUST	1	
9	14751ZE2003	SPRING, VALVE	2	
10	14771ZE2000	RETAINER, INTAKE VALVE SPRING	1	
11	14773ZE2000	RETAINER, EXHAUST VALVE SPRING	1	
12	14775ZE2010	SEAT, VALVE SPRING	1	
13	14781ZE2000	ROTATOR, VALVE	1	
14	14791ZE2010	PLATE, PUSH ROD GUIDE	1	
15	90012ZE0010	BOLT, PIVOT 8MM	2	
16	90206ZE1000	NUT, PIVOT ADJ.	2	
17	12209ZE8003	SEAL, VALVE STEM	1	

HONDA GX390U1QWT2 ENG. — CARBURETOR ASSY.

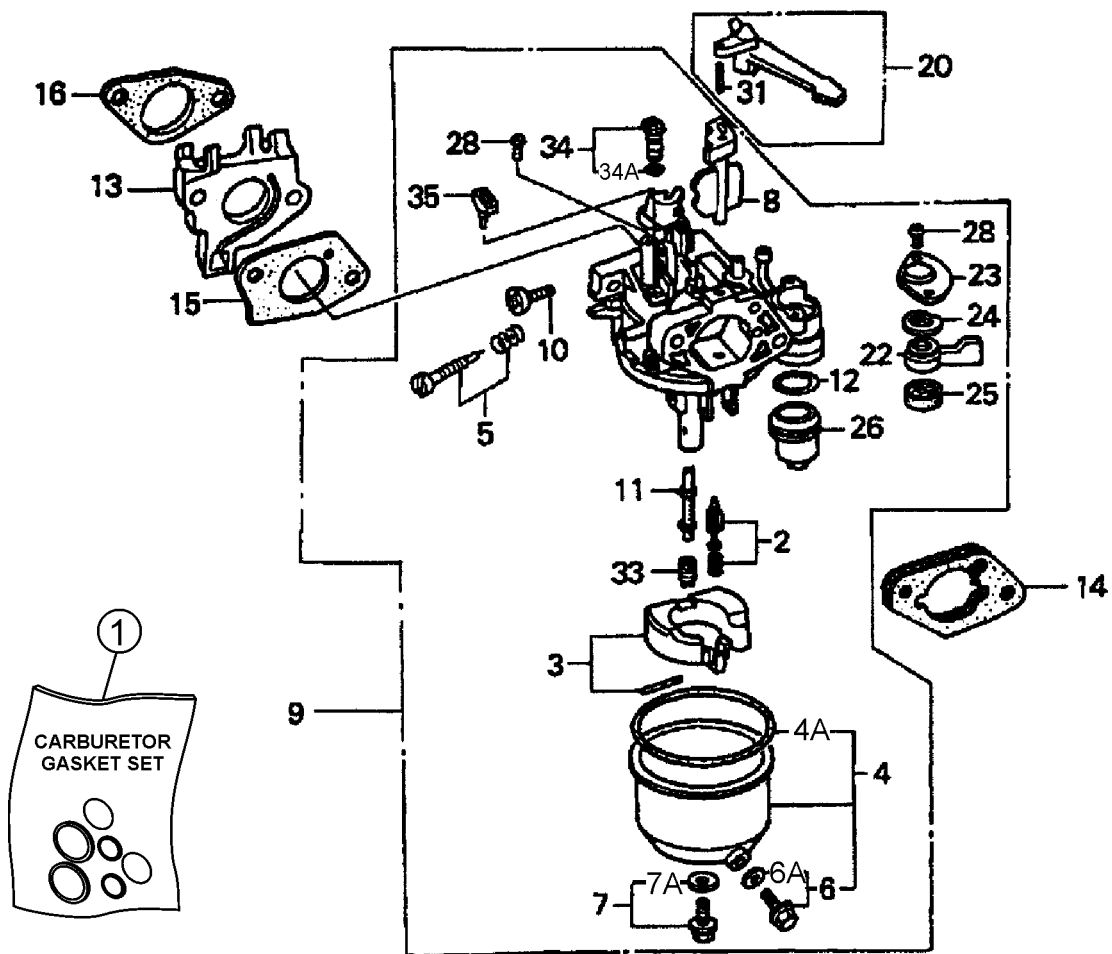

HONDA GX390U1QWT2 ENG. — CARBURETOR ASSY.

<u>NO.</u>	<u>PART NO.</u>	<u>PART NAME</u>	<u>QTY.</u>	<u>REMARKS</u>
1	16010ZE2812	CARBURETOR, GASKET SET	1.....	INCLUDES ITEMS W/+
2\$	16011ZA0931	VALVE SET, FLOAT	1	
3\$	16013ZA0931	FLOAT SET	1	
4\$	16015ZE8005	CHAMBER SET, FLOAT	1.....	INCLUDES ITEM 4A
			INCLUDES ITEM W/>
4A+		GASKET, CHAMBER SET FLOAT		NOT SOLD SEPARATELY
5\$	16016ZH7W01	SCREW SET, PILOT	1	
6\$>	16024ZE1811	SCREW SET, DRAIN,	1.....	INCLUDES ITEM 6A
6A+		GASKET, SCREW SET DRAIN		NOT SOLD SEPARATELY
7\$	16028ZE0005	SCREW SET	1.....	INCLUDES ITEM 7A
7A+		GASKET, SCREW SET		NOT SOLD SEPARATELY
8\$	16044ZE3W20	CHOKE SET	1	
9\$	16100ZF6V21	CARBURETOR ASSY. (BE85C B)	1.....	INCLUDES ITEMS W/\$
10\$	16124ZE0005	SCREW, THROTTLE STOP	1	
11\$	16166ZF6W10	NOZZLE, MAIN	1	
12\$+	16173001004	GASKET, FUEL STRAINER CUP	1	
13	16211ZF6000	INSULATOR, CARBURETOR	1	
14	16220ZA0702	SPACER, CARBURETOR	1	
15	16221ZF6800	GASKET, CARBURETOR	1	
16	16223ZE3W00	GASKET, INSULATOR	1	
20	16610ZE1000	LEVER, CHOKE (STD).....	1.....	INCLUDES ITEM W/@
22\$	16953ZE1812	LEVER, VALVE	1	
23\$	16954ZE1812	PLATE, LEVER SETTING	1	
24\$	16956ZE1811	SPRING, VALVE LEVER	1	
25\$+	16957ZE1812	GASKET, VALVE	1	
26\$	16967ZE0811	CUP, FUEL STRAINER	1	
28\$	93500030061H	SCREW, PAN (3X6)	2	
31@	9430520122	PIN, SPRING (2X12)	1	
33\$	99101ZH80950	JET, MAIN (#95) (OPTIONAL)	1	
33\$	99101ZH80980	JET, MAIN (#98) (OPTIONAL)	1	
33\$	99101ZH81000	JET, MAIN (#100)	1	
34\$	99204ZA00450	JET SET, PILOT (#45)	1.....	INCLUDES ITEM 34A
34A+		GASKET, JET SET PILOT (#45).....		NOT SOLD SEPARATELY
35\$	16172ZE3W10	COLLAR, SET	1	

HONDA GX390U1QWT2 ENG. — CONTROL ASSY.

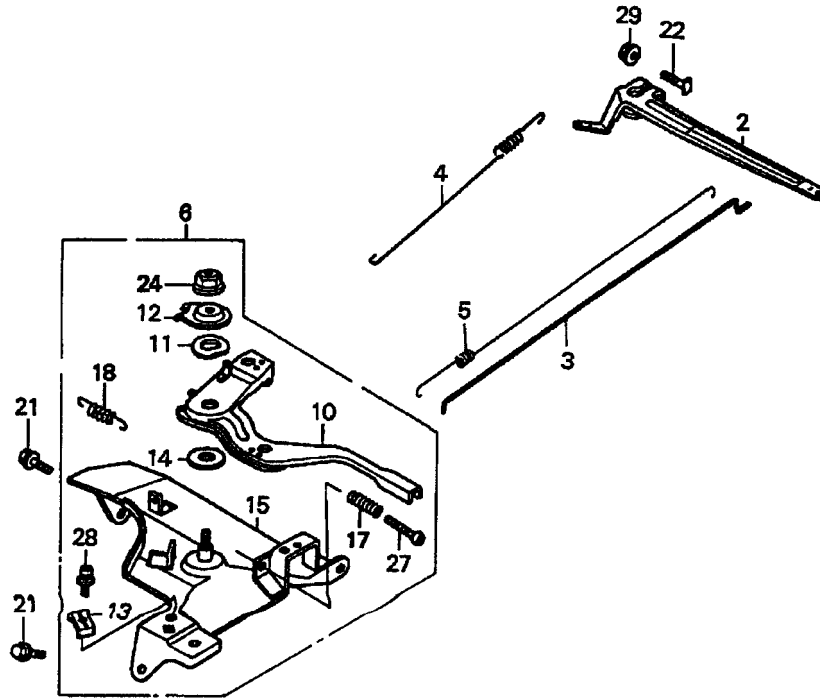

HONDA GX390U1QWT2 ENG. — CONTROL ASSY.

<u>NO.</u>	<u>PART NO.</u>	<u>PART NAME</u>	<u>QTY.</u>	<u>REMARKS</u>
2	16551ZE3000	ARM, GOVERNOR	1	
3	16555ZE3000	ROD, GOVERNOR	1	
4	16561ZE3000	SPRING, GOVERNOR	1	
5	16562ZE3000	SPRING, THROTTLE RETURN	1	
6	16570ZE3W20	CONTROL ASSY. (REMOTE)	1.....	INCLUDES ITEMS W/@
10@	16571ZE3W00	LEVER, CONTROL	1	
11@	16574ZE1000	SPRING, LEVER	1	
12@	16575ZE2W00	WASHER, CONTROL LEVER	1	
13@	16576891000	HOLDER, CABLE	1	
14@	16578ZE1000	SPACER, CONTROL LEVER	1	
15@	16581ZE3W00	BASE, CONTROL	1	
17@	16584883300	SPRING, CONTROL ADJUSTING	1	
18@	16592883310	SPRING, CABLE RETURN	1	
21	90013883000	BOLT, FLANGE (6X12) (CT200)	2	
22	90015ZE5010	BOLT, GOVERNOR ARM	1	
24@	90114SA0000	NUT, SELF-LOCK (6MM)	1	
27@	93500050320A	SCREW, PAN (5X32)	1	
28@	93500050160A	SCREW, PAN (5X16)	1	
29	9405006000	NUT, FLANGE (6MM)	1	

HONDA GX390U1QWT2 ENG. — CRANKCASE ASSY.

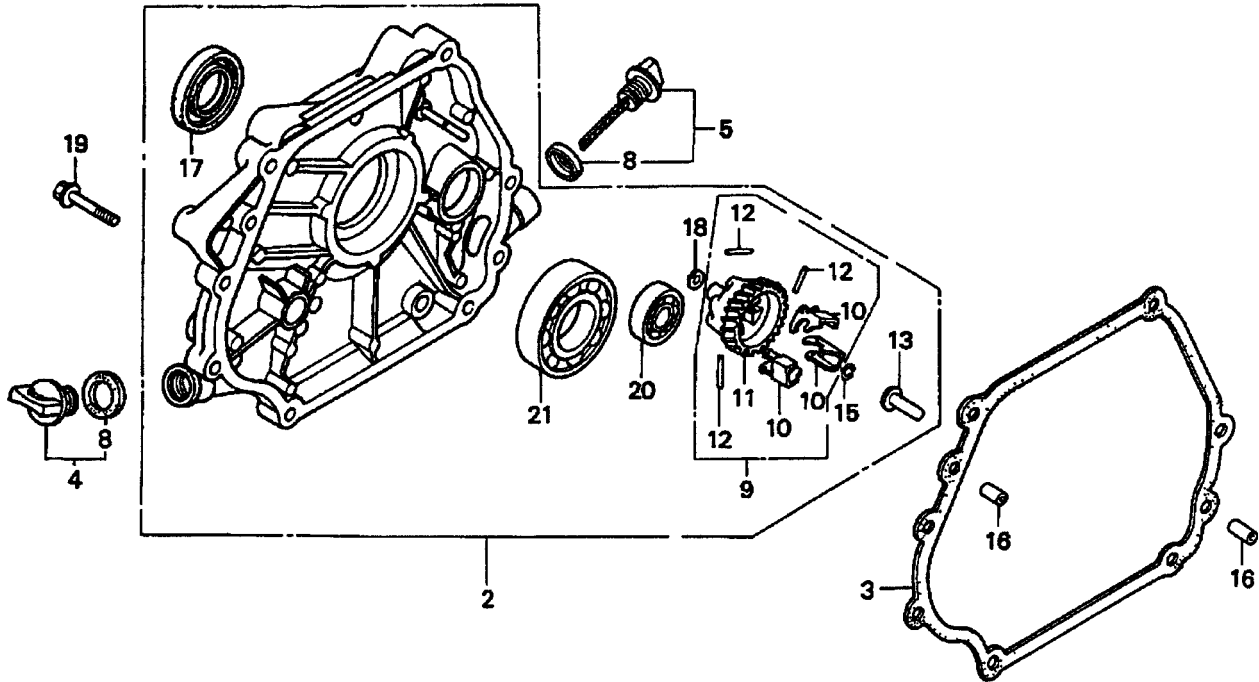

HONDA GX390U1QWT2 ENG. — CRANKCASE ASSY.

<u>NO.</u>	<u>PART NO.</u>	<u>PART NAME</u>	<u>QTY.</u>	<u>REMARKS</u>
2	11300ZE3604	COVER ASSY., CRANKCASE	1.....	INCLUDES ITEMS W/\$
3	11381ZE3801	GASKET, CASE COVER	1	
4	15600ZG4003	CAP ASSY., OIL FILLER.....	1.....	INCLUDES ITEM W/#
5	15600735003	CAP ASSY., OIL FILLER.....	1.....	INCLUDES ITEM W/@
8#@	15625ZE1003	GASKET, OIL FILLER CAP	2	
9	16510ZE3000	GOVERNOR ASSY.....	1.....	INCLUDES ITEMS W/+
10>%\$+	16511ZE8000	WEIGHT, GOVERNOR	3	
11>%\$+	16512ZE3000	HOLDER, GOVERNOR WEIGHT	1	
12>%\$+	16513ZE2000	PIN, GOVERNOR WEIGHT	3	
13>%\$	16531Z0A000	SLIDER, GOVERNOR	1	
15>%\$	90602ZE1000	CLIP, GOVERNOR HOLDER	1	
16	90701HC4000	PIN, DOWEL (8X12)	2	
17>%\$	91201ZE3004	OIL SEAL (35X52X8)	1	
18>%\$	9410106800	WASHER, PLAIN (6MM)	1	
19	957010804000	BOLT, FLANGE (8X40)	7	
20>%\$	961006202000	BEARING, RADIAL BALL (6202)	1	
21>%\$	961006207000	BEARING, RADIAL BALL (6207)	1	

HONDA GX390U1QWT2 ENG. — CRANKSHAFT ASSY.

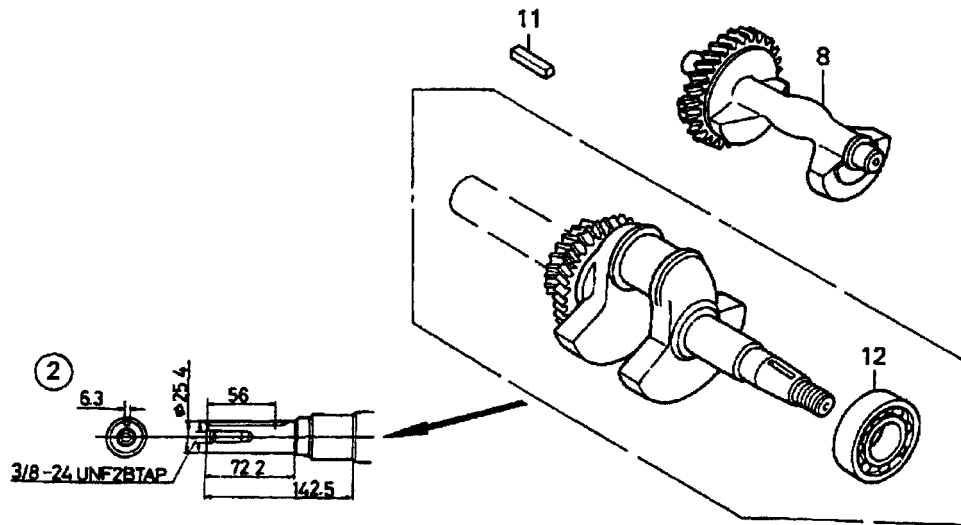

HONDA GX390U1QWT2 ENG. — CRANKSHAFT ASSY.

<u>NO.</u>	<u>PART NO.</u>	<u>PART NAME</u>	<u>QTY.</u>	<u>REMARKS</u>
2	13310ZF6W11	CRANKSHAFT	1.....	INCLUDES ITEM W/# S/N 1113739 AND BELOW
2	13310ZF6W12	CRANKSHAFT	1.....	INCLUDES ITEM W/+ S/N 1113740 AND ABOVE
8	13351ZE3010	WEIGHT, BALANCER	1	
11	90745ZE2600	KEY(6.3X6.3X43)	1	
12#	91001ZF6003	BEARING, RADIAL BALL (6207S)	1.....	S/N 1113739 AND BELOW
12+	91001ZF6013	BEARING, RADIAL BALL (6207SH).....	1.....	S/N 1113740 AND ABOVE

HONDA GX390U1QWT2 ENG. — CYLINDER BARRELL ASSY.

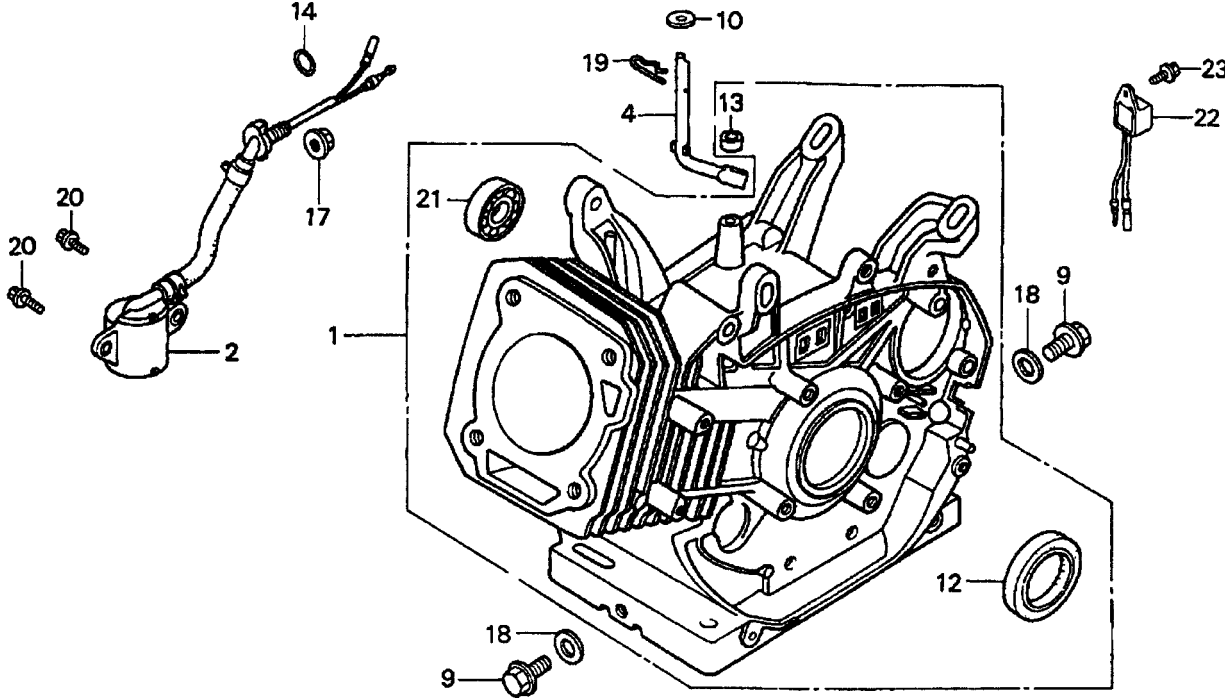

HONDA GX390U1QWT2 ENG. — CYLINDER BARRELL ASSY.

<u>NO.</u>	<u>PART NO.</u>	<u>PART NAME</u>	<u>QTY.</u>	<u>REMARKS</u>
1	12000ZF6417	CYLINDER ASSY.	1.....	INCLUDES ITEMS W/#
2	15510ZE2043	SWITCH ASSY., OIL LEVEL.....	1.....	S/N 1412956 AND BELOW
2	15510ZE2053	SWITCH ASSY., OIL LEVEL.....	1.....	S/N 1412957 AND ABOVE
4	16541ZE3010	SHAFT, GOVERNOR ARM	1	
9	90131883000	BOLT, DRAIN PLUG 12X15	2	
10	90446KE1000	WASHER (8.2X17X0.8)	1	
12#	91201ZE3004	OIL SEAL (35X52X8)	1	
13	91203952771	OIL SEAL (8X14X5)	1	
14	91353671004	O-RING (14MM) (NOK)	1	
17	9405010000	NUT, FLANGE (10MM)	1	
18	9410912000	WASHER, DRAIN PLUG (12MM)	2	
19	9425110000	PIN, LOCK (10MM)	1	
20	957010601200	BOLT, FLANGE (6X12)	2	
21#	961006202000	BEARING, RADIAL BALL (6202)	1	
22	34150ZH7003	ALERT UNIT, OIL.....	1.....	S/N 1419413 AND BELOW
22	34150ZH7013	ALERT UNIT, OIL.....	1.....	S/N 1419414 AND ABOVE
23	90013883000	BOLT, FLANGE (6X12) (CT200)	1	

HONDA GX390U1QWT2 ENG. — CYLINDER HEAD ASSY.

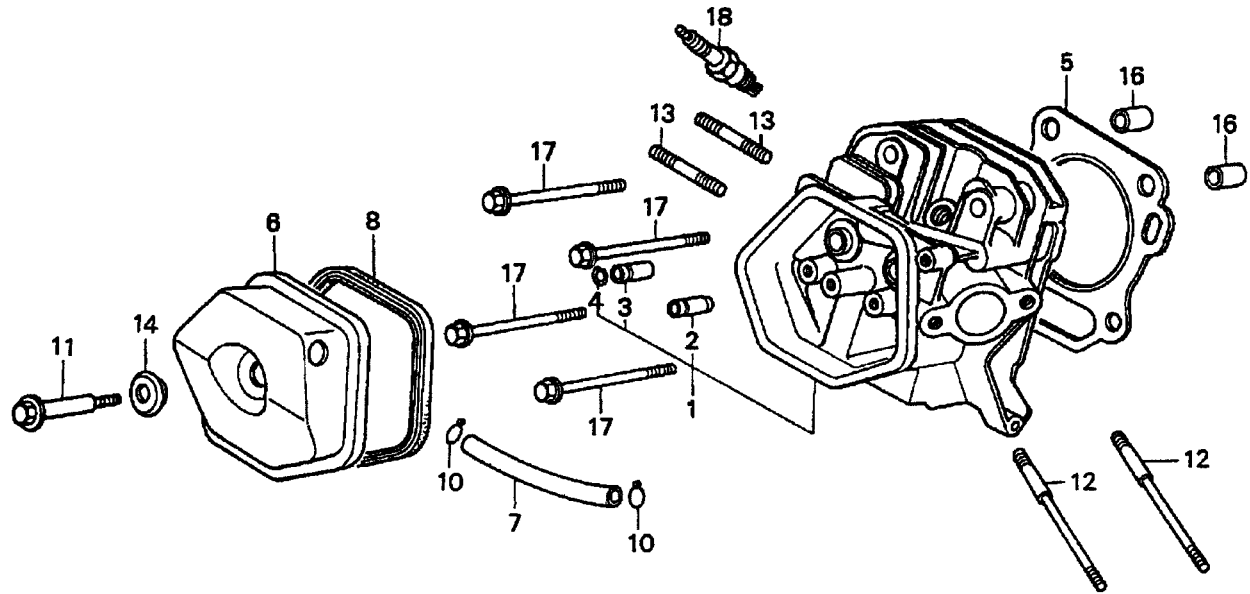

HONDA GX390U1QWT2 ENG. — CYLINDER HEAD ASSY.

<u>NO.</u>	<u>PART NO.</u>	<u>PART NAME</u>	<u>QTY.</u>	<u>REMARKS</u>
1	12200ZF6406	CYLINDER HEAD.....	1.....	INCLUDES ITEMS W/%
2%	12204ZE2306	GUIDE, VALVE (OS) (OPTIONAL)	1	
3%	12205ZE2305	GUIDE, EX. VALVE (OS) (OPTIONAL)	1	
4%	12216ZE2300	CLIP, VALVE GUIDE	1	
5	12251ZF6W00	GASKET, CYLINDER HEAD	1	
6	12310ZE3791	COVER, HEAD	1	
7	12315ZE3840	TUBE, BREATHER	1	
8	12391ZE2020	GASKET, CYLINDER HEAD COVER	1	
10	17316611000	CLIP, BREATHER TUBE	2	
11	90014ZE2000	BOLT, HEAD COVER	1	
12	90042ZE8000	BOLT, STUD (8X131.5)	2	
13	92900080320E	BOLT 2, STUD (8X32)	2	
14	90441ZE2010	WASHER, HEAD COVER	1	
16	9430112200	PIN A, DOWEL (12X20)	2	
17	957251008000	BOLT, FLANGE (10X80)	4.....	S/N 1411816 AND BELOW
17	957011008000	BOLT, FLANGE (10X80)	4.....	S/N 1411817 AND ABOVE
18	9807955846	SPARK PLUG (BPR5ES) (NGK) (OPT.)	1	
18	9807955855	SPARK PLUG (W16EPR-U) (DENSO)	1	
18	9807956846	SPARK PLUG (BPR6ES) (NGK)	1	
18	9807956855	SPARK PLUG (W20EPR-U) (DENSO)	1	

HONDA GX390U1QWT2 ENG. — FAN COVER ASSY.

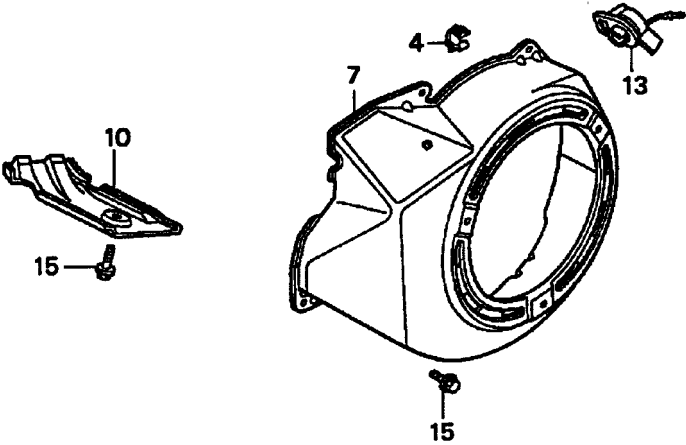

HONDA GX390U1QWT2 ENG. — FAN COVER ASSY.

<u>NO.</u>	<u>PART NO.</u>	<u>PART NAME</u>	<u>QTY.</u>	<u>REMARKS</u>
4	16731ZE2003	CLIP, TUBE	1	
7	19610ZE3010ZB	COVER, FAN *NH1* (BLACK)	1	
10	19631ZE3W00	SHROUD	1	
13	36100ZF6P81	SWITCH ASSY., ENGINE STOP	1.....	S/N 1412956 AND BELOW
13	36100ZF6P82	SWITCH ASSY., ENGINE STOP	1.....	S/N 1412957 AND ABOVE
15	90013883000	BOLT, FLANGE (6X12) (CT200)	6	

HONDA GX390U1QWT2 ENG. — FLYWHEEL ASSY.

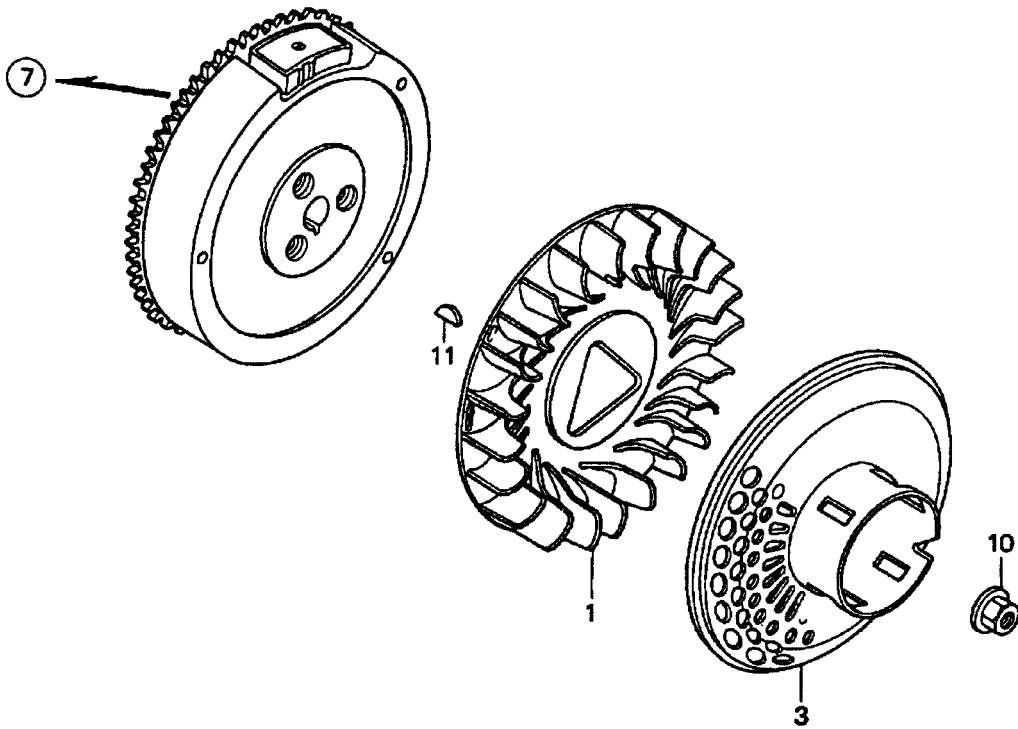

HONDA GX390U1QWT2 ENG. — FLYWHEEL ASSY.

<u>NO.</u>	<u>PART NO.</u>	<u>PART NAME</u>	<u>QTY.</u>	<u>REMARKS</u>
1	19511ZE3000	FAN, COOLING	1	
3	28450ZE3W11	PULLEY, STARTER (SCREEN GRID)	1	
7	31100ZE3701	FLYWHEEL	1	
10	90201ZE3V00	NUT, SPECIAL (16MM) (1)	1.....	S/N 1317976 AND BELOW
10	90201ZE3790	NUT, SPECIAL (16MM) (1)	1.....	S/N 1317977 AND ABOVE
11	90741ZE2000	KEY, SPECIAL WOODRUFF (25X18)	1	

HONDA GX390U1QWT2 ENG. — FUEL TANK ASSY.

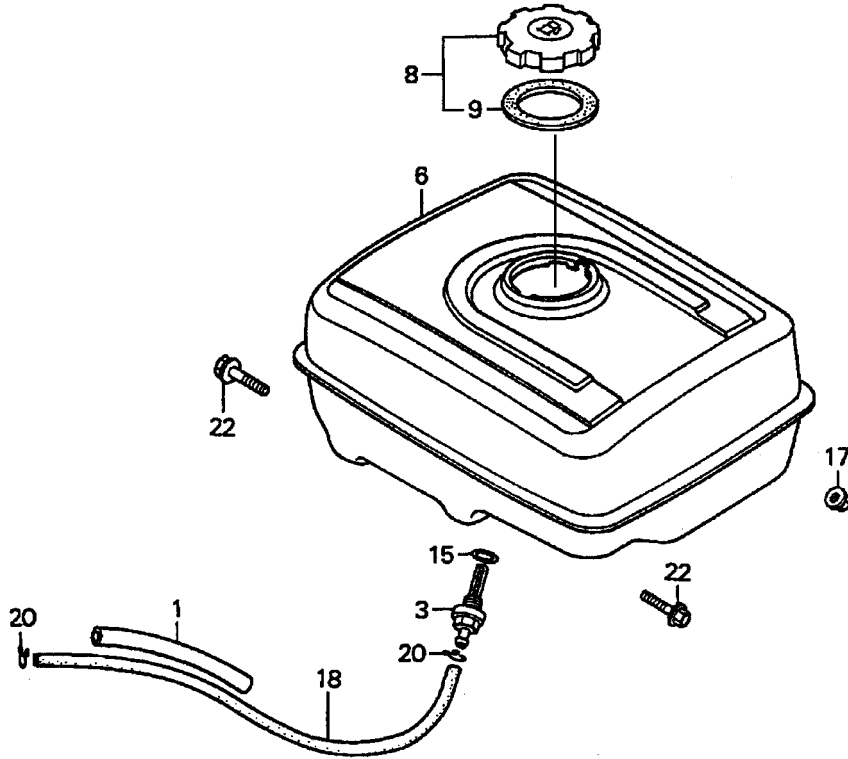

HONDA GX390U1QWT2 ENG. — FUEL TANK ASSY.

<u>NO.</u>	<u>PART NO.</u>	<u>PART NAME</u>	<u>QTY.</u>	<u>REMARKS</u>
1	16854ZH8000	RUBBER, SUPPORTER (107MM)	1	
3	16955ZE1000	JOINT, FUEL TANK	1	
6	17510ZE3020ZB	TANK, FUEL *NH1*	1	S/N 1213085 AND BELOW
6	17510ZE3800ZA	TANK, FUEL *NH1*	1	S/N 1213086 THRU 1383799
6	17510ZE3801ZA	TANK, FUEL *NH1*	1	S/N 1383800 AND ABOVE
8	17620Z0T305	CAP, FUEL FILLER (CHROME PLATED)	1	INCLUDES ITEM W/#
9#	17631Z0T812	GASKET, FUEL FILLER CAP 39X62X3	1	
15	91353671004	O-RING (14MM) (NOK)	1	
17	9405008000	NUT, FLANGE (8MM)	2	
18	950014523540	BULK HOSE, FUEL (4.5X235)	1	REPLACES 950014500160M
			S/N 1105013 AND BELOW
18	91424Z5L801	BULK HOSE, FUEL (4.5X235) (FKM)	1	S/N 1105014 AND ABOVE
20	9500202080	CLIP, TUBE (B8).....	2	S/N 1105013 AND BELOW
20	950024080008	CLAMP, TUBE (D8).....	2	S/N 1105014 AND ABOVE
22	957010802500	BOLT, FLANGE (8X25)	2	

HONDA GX390U1QWT2 ENG. — IGNITION COIL ASSY.

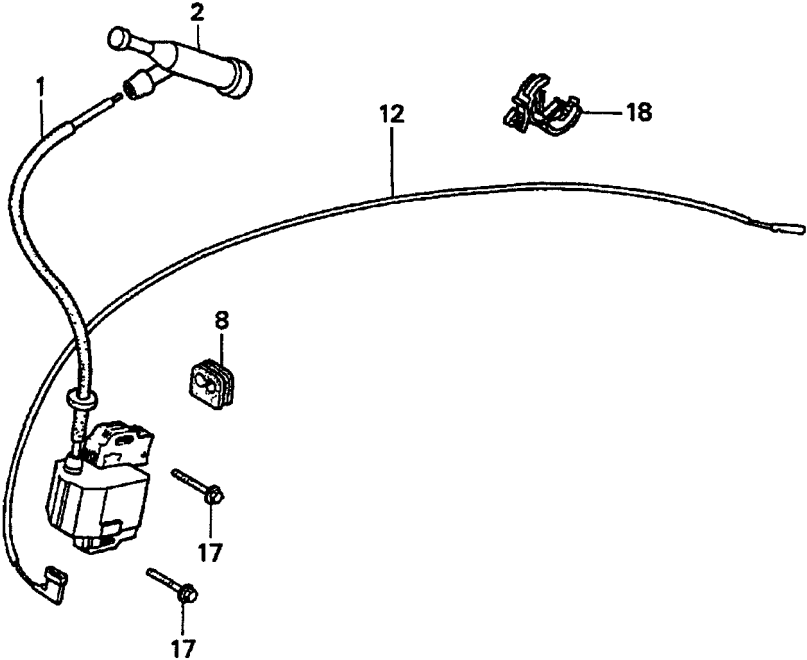

HONDA GX390U1QWT2 ENG. — IGNITION COIL ASSY.

<u>NO.</u>	<u>PART NO.</u>	<u>PART NAME</u>	<u>QTY.</u>	<u>REMARKS</u>
1	30500ZF6W02	COIL ASSY., IGNITION.....	1.....	S/N 1411816 AND BELOW
1	30500ZF6W03	COIL ASSY., IGNITION.....	1.....	S/N 1411817 AND ABOVE
2	30700ZE1013	CAP ASSY., NOISE SUPPRESSOR	1	
8	31512ZE2000	GROMMET, WIRE	1	
12	36101ZE2701	WIRE, STOP SWITCH (430MM)	1	
17	90015883000	BOLT, FLANGE (6X28)	2	
18	90684ZA0601	CLIP, WIRE HARNESS	1	

HONDA GX390U1QWT2 ENG. — MUFFLER ASSY.

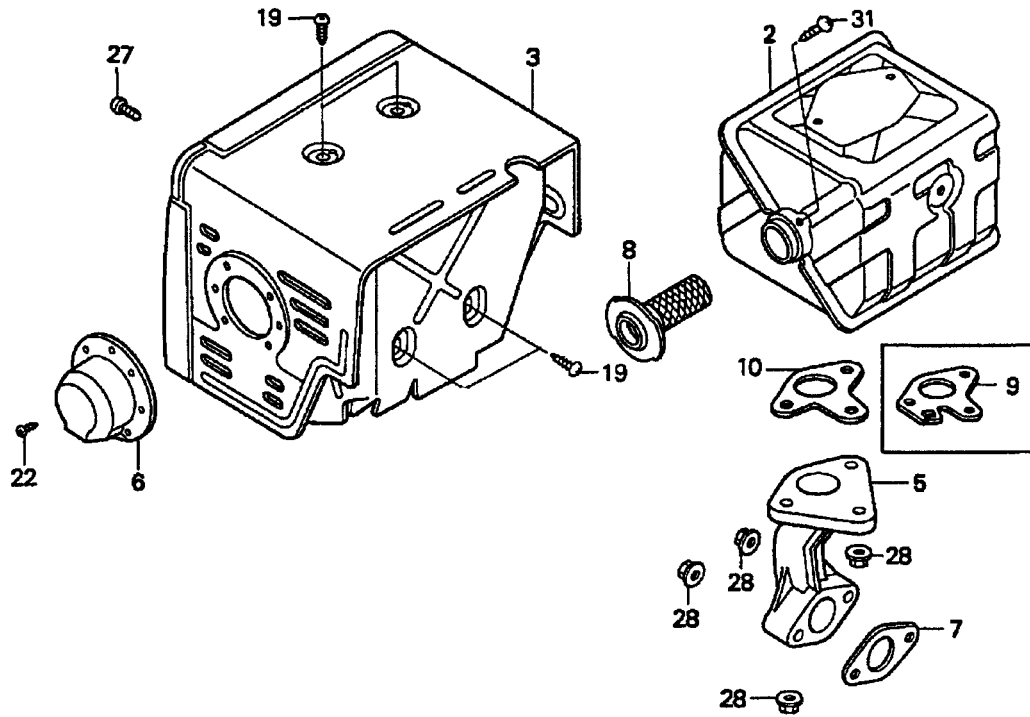

HONDA GX390U1QWT2 ENG. — MUFFLER ASSY.

<u>NO.</u>	<u>PART NO.</u>	<u>PART NAME</u>	<u>QTY.</u>	<u>REMARKS</u>
2	18310ZE2W61	MUFFLER	1	
3	18320ZE2W61	PROTECTOR, MUFFLER	1	
5	18330ZE2W00	PIPE, EX.	1	
6	18331ZE3810	CAP, MUFFLER	1	S/N 1166160 AND BELOW
6	18331ZE3811	CAP, MUFFLER	1	S/N 1166161 AND ABOVE
7	18333ZF6W01	GASKET, EX. PIPE	1	
8	18355ZE2W00	ARRESTER, SPARK (OPTIONAL)	1	
9	18381ZE2W10	GASKET, MUFFLER (ARRESTER) (OPTIONAL)	1	
10	18381ZE2800	GASKET, MUFFLER	1	
19	90050ZE1000	SCREW, TAPPING (5X8)	4	
22	90055ZE1000	SCREW, TAPPING (4X6)	3	
27	90006ZE2000	SCREW, TAPPING (6X10)	1	
28	9405008000	NUT, FLANGE (8MM)	5	
31	90055ZE1000	SCREW, TAPPING (4X6)	1	

HONDA GX390U1QWT2 ENG. — PISTON ASSY.

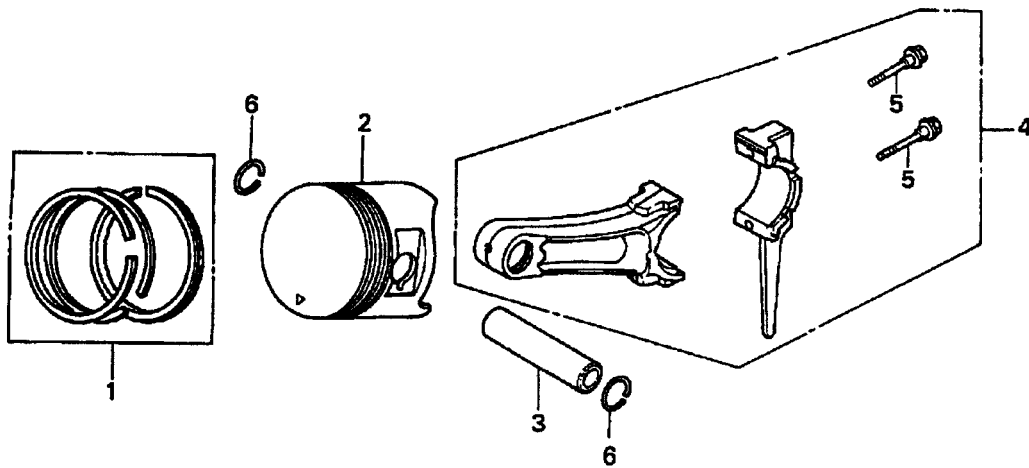

HONDA GX390U1QWT2 ENG. — PISTON ASSY.

<u>NO.</u>	<u>PART NO.</u>	<u>PART NAME</u>	<u>QTY.</u>	<u>REMARKS</u>
1	13010ZF6005	RING SET, PISTON (STD)	1	
1	13011ZF6005	RING SET, PISTON (0.25)	1	
1	13012ZF6005	RING SET, PISTON (0.50)	1	
1	13013ZF6005	RING SET, PISTON (0.75)	1	
2	13101ZF6W00	PISTON (STD)	1	
2	13102ZF6W00	PISTON (0.25)	1	
2	13103ZF6W00	PISTON (0.50)	1	
2	13104ZF6W00	PISTON (0.75)	1	
3	13111ZF6W00	PIN, PISTON	1	
4	13200ZE3020	ROD ASSY., CONNECTING (STD)	1	INCLUDES ITEM W/@
4	13200ZE3315	ROD ASSY., CONNECTING (0.25 UNDERSIZE)	1	
5@	90001ZE8000	BOLT, CONNECTING ROD	2	
6	90601ZE3000	CLIP, PISTON PIN (20MM)	2	

HONDA GX390U1QWT2 ENG. — RECOIL STARTER ASSY.

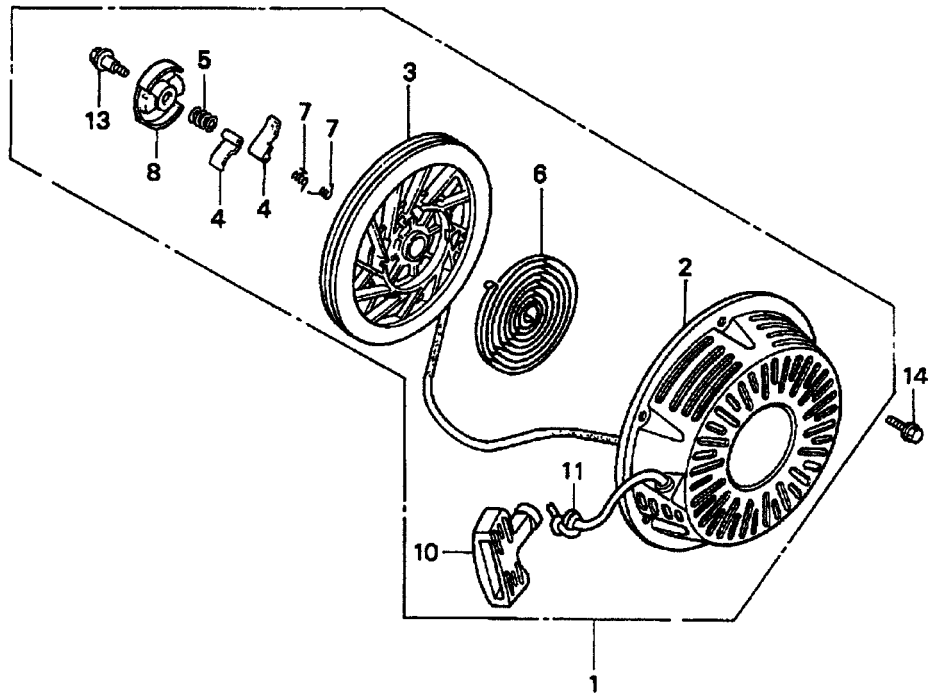

HONDA GX390U1QWT2 ENG. — RECOIL STARTER ASSY.

<u>NO.</u>	<u>PART NO.</u>	<u>PART NAME</u>	<u>QTY.</u>	<u>REMARKS</u>
1	28400ZE3W01ZB	STARTER ASSY., RECOIL @NH1@ (BLACK).....	1	INCLUDES ITEMS W/@
2@	28410ZE3W01ZB	CASE, RECOIL STARTER @NH1@ (BLACK)	1	
3@	28421ZE3W01	PULLEY, RECOIL STARTER	1	
4@	28422ZE2W01	RATCHET, STARTER	2	
5@	28441ZE2W01	SPRING, FRICTION	1	
6@	28442ZE2W01	SPRING, STARTER RETURN	1	
7@	28443ZE2W01	SPRING, RATCHET	2	
8@	28444ZE2W01	RETAINER, SPRING	1	
10@	28461ZE2W02	GRIP, STARTER	1	
11@	28462ZE3W01	ROPE, RECOIL STARTER	1	
13@	90004ZE2W01	SCREW, CENTER	1	
14	90008ZE2003	BOLT, FLANGE (6X10)	3	

HONDA GX390U1QWT2 ENG. — LABELS ASSY.

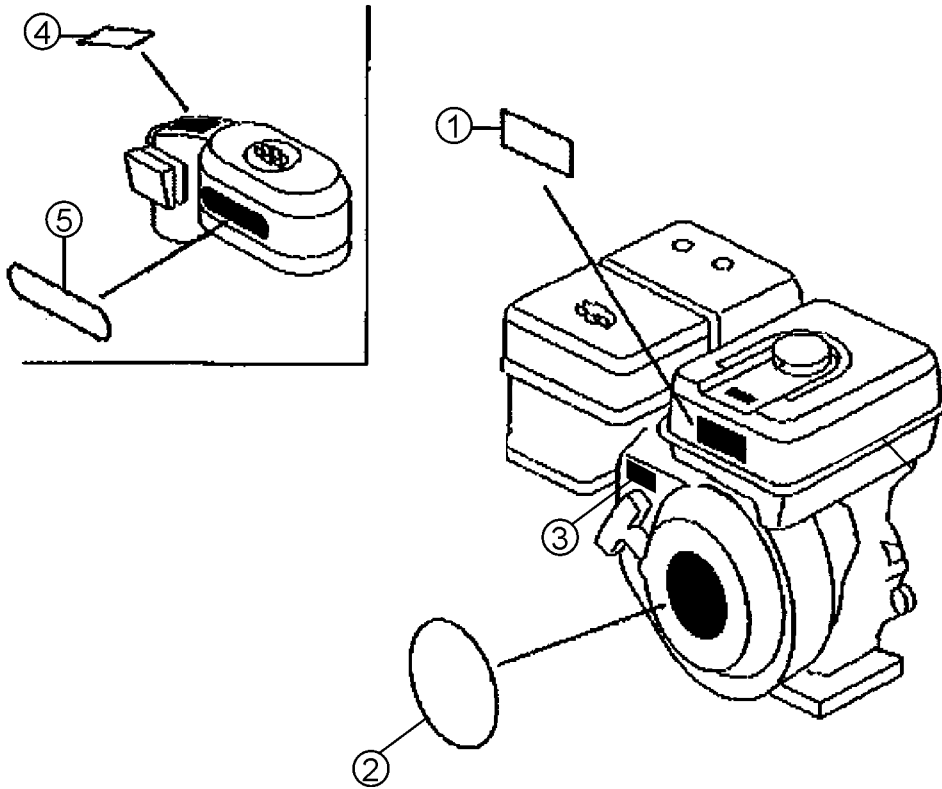

HONDA GX390U1QWT2 ENG. — LABELS ASSY.

<u>NO.</u>	<u>PART NO.</u>	<u>PART NAME</u>	<u>QTY.</u>	<u>REMARKS</u>
1	87516ZH7000	MARK OPERATOR CAUTION	1	
1	87516ZH7810	MARK OPERATOR PICTOGRAPH (OPTION)	1	
2	87521ZF6W03	EMBLEM (GX390 HONDA 13.0)	1	S/N 1398206 AND BELOW
2	87521ZF6W04	EMBLEM (GX390 HONDA 13.0)	1	S/N 1398207 AND ABOVE
3	87532ZH7000	MARK, THROTTLE INDICATION	1	
4	87534ZE1841	LABEL, AIR CLEANER CAUTION	1	
5	87535ZE1841	MARK, AIR CLEANER SALES POINT	1	

TERMS AND CONDITIONS OF SALE — PARTS

PAYMENT TERMS

Terms of payment for parts are net 30 days.

FREIGHT POLICY

All parts orders will be shipped collect or prepaid with the charges added to the invoice. All shipments are F.O.B. point of origin. Multiquip's responsibility ceases when a signed manifest has been obtained from the carrier, and any claim for shortage or damage must be settled between the consignee and the carrier.

MINIMUM ORDER

The minimum charge for orders from Multiquip is \$15.00 net. Customers will be asked for instructions regarding handling of orders not meeting this requirement.

RETURNED GOODS POLICY

Return shipments will be accepted and credit will be allowed, subject to the following provisions:

1. A Returned Material Authorization must be approved by Multiquip prior to shipment.
2. To obtain a Return Material Authorization, a list must be provided to Multiquip Parts Sales that defines item numbers, quantities, and descriptions of the items to be returned.
 - a. The parts numbers and descriptions must match the current parts price list.
 - b. The list must be typed or computer generated.
 - c. The list must state the reason(s) for the return.
 - d. The list must reference the sales order(s) or invoice(s) under which the items were originally purchased.
 - e. The list must include the name and phone number of the person requesting the RMA.
3. A copy of the Return Material Authorization must accompany the return shipment.
4. Freight is at the sender's expense. All parts must be returned freight prepaid to Multiquip's designated receiving point.

5. Parts must be in new and resalable condition, in the original Multiquip package (if any), and with Multiquip part numbers clearly marked.
6. The following items are not returnable:
 - a. Obsolete parts. (If an item is in the price book and shows as being replaced by another item, it is obsolete.)
 - b. Any parts with a limited shelf life (such as gaskets, seals, "O" rings, and other rubber parts) that were purchased more than six months prior to the return date.
 - c. Any line item with an extended dealer net price of less than \$5.00.
 - d. Special order items.
 - e. Electrical components.
 - f. Paint, chemicals, and lubricants.
 - g. Decals and paper products.
 - h. Items purchased in kits.
7. The sender will be notified of any material received that is not acceptable.
8. Such material will be held for five working days from notification, pending instructions. If a reply is not received within five days, the material will be returned to the sender at his expense.
9. Credit on returned parts will be issued at dealer net price at time of the original purchase, less a 15% restocking charge.
10. In cases where an item is accepted, for which the original purchase document can not be determined, the price will be based on the list price that was effective twelve months prior to the RMA date.
11. Credit issued will be applied to future purchases only.

PRICING AND REBATES

Prices are subject to change without prior notice. Price changes are effective on a specific date and all orders received on or after that date will be billed at the revised price. Rebates for price declines and added charges for price increases will not be made for stock on hand at the time of any price change.

Multiquip reserves the right to quote and sell direct to Government agencies, and to Original Equipment Manufacturer accounts who use our products as integral parts of their own products.

SPECIAL EXPEDITING SERVICE

A \$35.00 surcharge will be added to the invoice for special handling including bus shipments, insured parcel post or in cases where Multiquip must personally deliver the parts to the carrier.

LIMITATIONS OF SELLER'S LIABILITY

Multiquip shall not be liable hereunder for damages in excess of the purchase price of the item with respect to which damages are claimed, and in no event shall Multiquip be liable for loss of profit or good will or for any other special, consequential or incidental damages.

LIMITATION OF WARRANTIES

No warranties, express or implied, are made in connection with the sale of parts or trade accessories nor as to any engine not manufactured by Multiquip. Such warranties made in connection with the sale of new, complete units are made exclusively by a statement of warranty packaged with such units, and Multiquip neither assumes nor authorizes any person to assume for it any other obligation or liability whatever in connection with the sale of its products. Apart from such written statement of warranty, there are no warranties, express, implied or statutory, which extend beyond the description of the products on the face hereof.

Effective: February 22, 2006

PARTS MANUAL

HERE'S HOW TO GET HELP

PLEASE HAVE THE MODEL AND SERIAL
NUMBER ON-HAND WHEN CALLING

UNITED STATES

Multiquip Corporate Office

18910 Wilmington Ave.
Carson, CA 90746
Contact: mq@multiquip.com

Tel. (800) 421-1244
Fax (800) 537-3927

Mayco Parts

800-306-2926
310-537-3700

Fax: 800-672-7877
Fax: 310-637-3284

Service Department

800-421-1244
310-537-3700

Fax: 310-537-4259

MQ Parts Department

800-427-1244
310-537-3700

Fax: 800-672-7877
Fax: 310-637-3284

Warranty Department

800-421-1244, Ext. 279
310-537-3700, Ext. 279

Fax: 310-537-1173

Technical Assistance

800-478-1244

Fax: 310-631-5032

MEXICO

MQ Cipsa

Carr. Fed. Mexico-Puebla KM 126.5
Momoxpan, Cholula, Puebla 72760 Mexico
Contact: pmastretta@cipsa.com.mx

Tel: (52) 222-225-9900
Fax: (52) 222-285-0420

UNITED KINGDOM

Multiquip (UK) Limited Head Office

Unit 2, Northpoint Industrial Estate,
Global Lane,
Dukinfield, Cheshire SK16 4UJ
Contact: sales@multiquip.co.uk

Tel: 0161 339 2223
Fax: 0161 339 3226

CANADA

Multiquip

4110 Industriel Boul.
Laval, Quebec, Canada H7L 6V3
Contact: jmartin@multiquip.com

Tel: (450) 625-2244
Tel: (877) 963-4411
Fax: (450) 625-8664

© COPYRIGHT 2010, MULTIQUIP INC.

Multiquip Inc and the MQ logo are registered trademarks of Multiquip Inc. and may not be used, reproduced, or altered without written permission. All other trademarks are the property of their respective owners and used with permission.

This manual MUST accompany the equipment at all times. This manual is considered a permanent part of the equipment and should remain with the unit if resold.

The information and specifications included in this publication were in effect at the time of approval for printing. Illustrations, descriptions, references and technical data contained in this manual are for guidance only and may not be considered as binding. Multiquip Inc. reserves the right to discontinue or change specifications, design or the information published in this publication at any time without notice and without incurring any obligations.

Your Local Dealer is:

