



SPARE PARTS MANUAL

FLEXTOOL PORTAVIBE® FVE44-2, FVE44-2G



Applies to product from Serial Number D07-10000

Version 4.0 (April 2025)

FOR MORE INFORMATION VISIT flextool.com.au

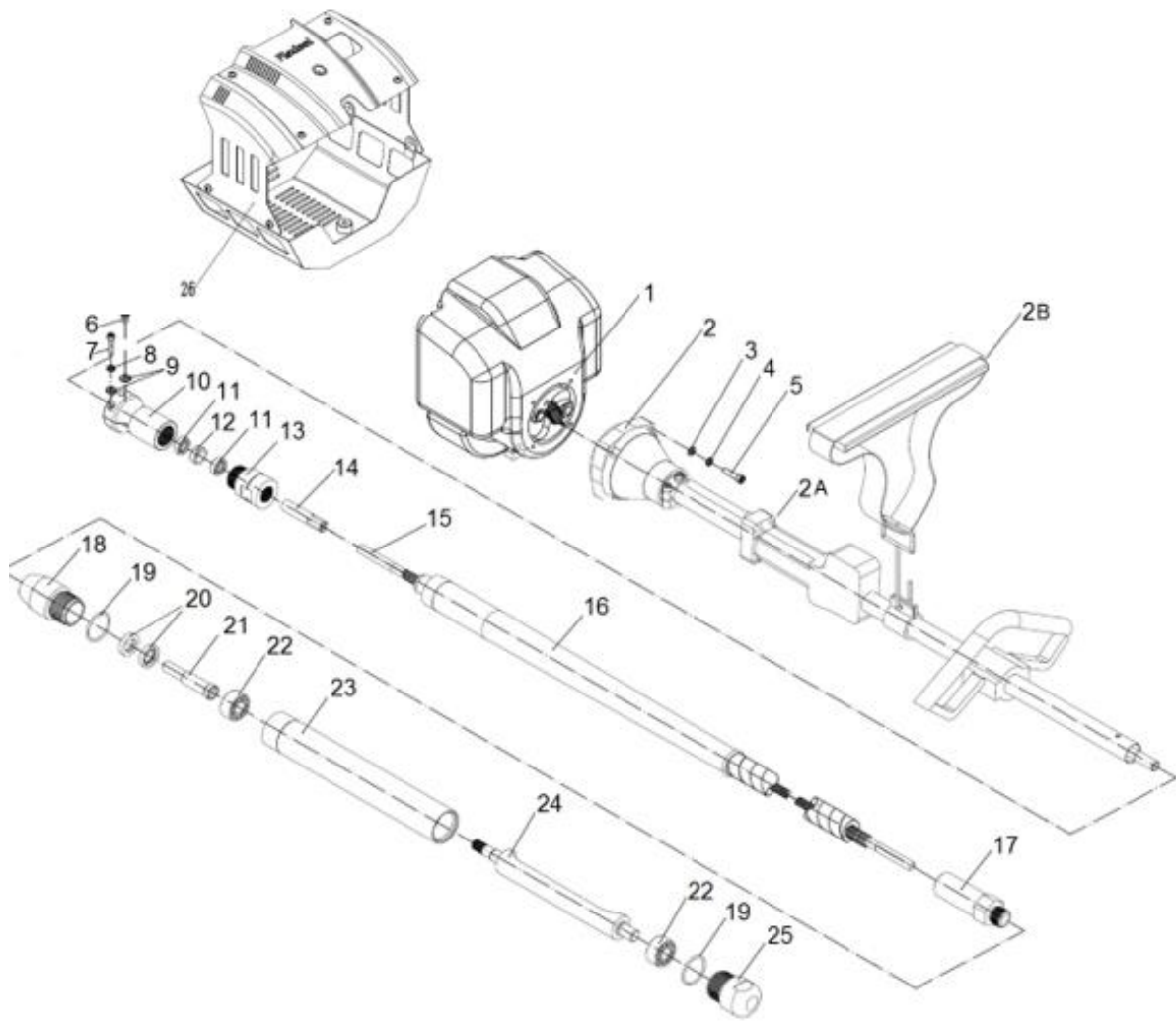

Flextool PortaVibe® (All Types)

Item No.	Product Code	Description	Qty	Remarks
1	NPS03318-UNIT	HON ENGINE GX35 (TSUT) PORTAVIBE (570614)	1	
2	NPS03320-UNIT	FLX DRIVE SHAFT & THROTTLE (086030)	1	Includes 2A, 2B
2A	NPS00994-UNIT	HON THROTTLE CONTROL & CABLE ASSY (H17850-VF9-S41)	1	
2B	NPSA0003-UNIT	HON SHOULDER STRAP ASSY (H90690-SAO-003)	1	
3	See Remarks	FLX FLAT WASHER 6MM (650103)	4	Use SK-1
4	See Remarks	FLX SPRING WASHER 6MM (650502)	4	Use SK-1
5	See Remarks	FLX BOLT SOCKET HEAD CAP M6 X 30MM (630433)	4	Use SK-1
6	See Remarks	FLX SCREW BUTTON HEAD CAP M6 X 16MM (590511)	1	Use AS-1
7	See Remarks	FLX BOLT SOCKET HEAD CAP M6 X 25MM (630404)	2	Use AS-1
8	See Remarks	FLX SPRING WASHER 6MM (650502)	2	Use AS-1
9	See Remarks	FLX WASHER (650302)	3	Use AS-1
10	See Remarks	FLX HOUSING PORTAVIBE COUPLING (086031)	1	Use AS-1
11	NPS01515-UNIT	FLX BEARING 6082Z (550508)	2	
12	See Remarks	FLX SPACER PORTAVIBE COUPLING (086032)	1	Use AS-1
13	See Remarks	FLX ADAPTOR (086033)	1	Use AS-1
14	See Remarks	FLX SEAL SLEEVE (086034)	1	Use AS-1
15	NPS03002-UNIT	FLX CORE PORTAVIBE 7.5X630 (810173)	1	
16	See Remarks	FLX CASING PORTAVIBE (086043)	1	Use AS-3
17	See Remarks	FLX CASING FERRULE (086035)	1	Use AS-3
18	See Remarks	FLX ADAPTOR BARREL (086037)	1	Use AS-2
19	See Remarks	FLX O-RING 32.5X3.55 (510432)	1	Use SK-2 or AS-2
20	See Remarks	FLX OIL SEAL 16X28.5X8 (530509)	2	Use SK-2 or AS-2
21	See Remarks	FLX ADAPTOR SPINDLE (086038)	1	Use AS-2
22	See Remarks	FLX BEARING NSK5202	2	Use SK-2 or AS-2
23	See Remarks	FLX BARREL (086039)	1	Use AS-2
24	See Remarks	FLX ROTOR PORTAVIBE (086040)	2	Use AS-2
25	NPS09333-UNIT	FLX NOSE CAP PORTAVIBE (086041)	1	
26	NPS01093-UNIT	FLX PORTAVIBE ENGINE GUARD ASSY FVE44 (086100)	1	

Assembly / Service Kits

Item No.	Product Code	Description	Qty	Remarks
SK-1	NPS03045-UNIT	FLX SERVICE KIT BOLT SET FVE44 (086030SK)	1	Inc Items: 3-5
SK-2	NPS328SK-UNIT	FLX SERVICE KIT PORTAVIBE HEAD (086451SKF)	1	Inc Items: 19,20,22

AS-1	NPS03282-UNIT	FLX ASSY COUPLING (086451GGF)	1	Inc Items: 6-14
AS-2	NPS09328-UNIT	FLX ASSY VIBRATOR HEAD FVE44 (086400F)	1	Inc Items: 18-25
AS-3	NPS03001-UNIT	FLX ASSY CASING PORTAVIBE (086451GF)	1	Inc Items: 16,17

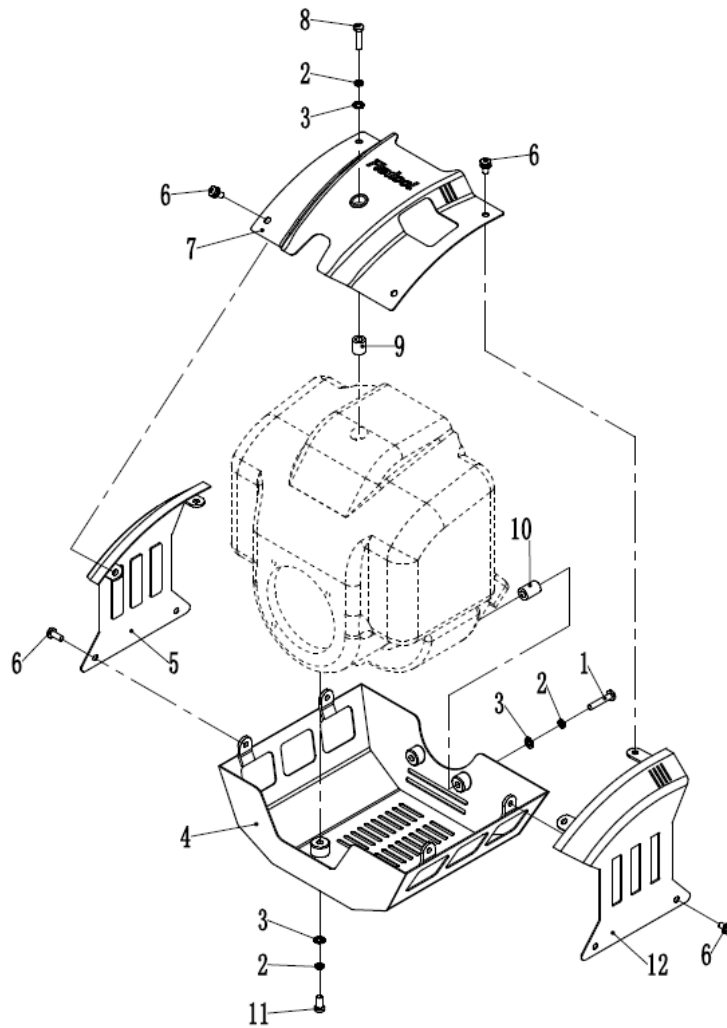

Engine Guard

Item No.	Product Code	Description	Qty	Remarks
1	See Remarks	FLX BOLT M5×40 (630738)	2	Use SK-1 or AS-1
2	See Remarks	FLX ELASTIC WASHER 5 (650501)	5	Use SK-1 or AS-1
3	See Remarks	FLX FLAT WASHER 5 (650301)	5	Use SK-1 or AS-1
4	See Remarks	FLX BASE PLATE (86101)	1	Use AS-1
5	See Remarks	FLX LEFT SIDE PLATE (86102)	1	Use AS-1
6	See Remarks	FLX BOLT WITH WASHER M5×12 (590432)	8	Use SK-1 or AS-1
7	See Remarks	FLX TOP PLATE (86103)	1	Use AS-1
8	See Remarks	FLX BOLT M5×35 (630739)	1	Use SK-1 or AS-1
9	See Remarks	FLX SLEEVE A (86104)	1	Use SK-1 or AS-1
10	See Remarks	FLX SLEEVE B (86068)	2	Use SK-1 or AS-1
11	See Remarks	FLX BOLT M5×16 (630713)	2	Use SK-1 or AS-1
12	See Remarks	FLX RIGHT SIDE PLATE (86105)	1	Use AS-1

Assembly / Service Kits

Item No.	Product Code	Description	Qty	Remarks
SK-1	NPS01094-UNIT	FLX SERVICE KIT BOLT SET ENGINE GUARD (FY-086100SK)	1	Inc Items: 1-3,6,8-11
AS-1	NPS01093-UNIT	FLX PORTAVIBE ENGINE GUARD ASSY FVE44 (FY-086100)	1	Inc Items: 1-12



Flextool

1956 Dandenong Road, Clayton VIC 3168, Australia

Phone (AUS): 1300 353 986

flextool.com.au

ABN 80 069 961 968

This manual summarises our best knowledge of the product based on the information available at the time of publication. You should read this manual carefully and consider the information in the context of how the product will be used. Our responsibility for products sold is subject to our standard terms and conditions of sale.

DISCLAIMER:

Any advice, recommendation, information, assistance or service provided by us in this manual is given in good faith and is believed by us to be appropriate and reliable. However, any advice, recommendation, information, assistance or service provided by us is provided without liability or responsibility PROVIDED THAT the foregoing shall not exclude, limit, restrict or modify the right entitlements and remedies conferred upon any person or the liabilities imposed upon us by any condition or warranty implied by Commonwealth, State or Territory Act or ordinance void or prohibiting such exclusion limitation or modification. The product can be expected to perform as indicated in this manual so long as operation and operational procedures of the individual products are followed as recommended in this manual.

Design and technical specifications may be subject to changes.

© This publication is copyright. All rights are reserved. Flextool and PortaVibe are registered trade marks of Parchem Construction Supplies Pty Ltd