



SPARE PARTS MANUAL

MQ WHITEMAN WALK-BEHIND POWER TROWEL HDA SERIES



U.S. Revision #7 (08/01/23)
AUS Version 2.0 (November 2024)

FOR MORE INFORMATION VISIT flextool.com.au

EXCLUSIVE TO



PARTS MANUAL



HDA-SERIES WALK-BEHIND TROWEL (HONDA GX340K1QA2/GX390K1QA2 GASOLINE ENGINE)

Revision #7 (08/01/23)

Original Version

To find the latest revision of this publication or associated operation manual, visit our website at: www.multiquip.com



THIS MANUAL MUST ACCOMPANY THE EQUIPMENT AT ALL TIMES.

PN: 13410

TABLE OF CONTENTS

HDA Series Walk-Behind Trowel

Explanation Of Code In Remarks Column..... 4
Suggested Spare Parts 5

Component Drawings

Nameplate And Decals 6-7
Standard Handle Assembly (Old Style) 8-9
Standard Handle Assembly (New Style)..... 10-11
Quick Pitch Handle Assembly (Old Style)..... 12-15
Quick Pitch Handle Assembly (New Style)..... 16-19
4-Blade Spider Assembly 20-21
Gearbox Assembly 22-23
Engine And Clutch Assembly (11 Hp)..... 24-25
Engine And Clutch Assembly (13 Hp)..... 26-27
Guard Ring Assembly (Old Style)..... 28-29
Guard Ring Assembly (New Style) 30-31
Stabilizer Ring Assembly 32-33
Blades And Pan Assembly..... 34-35
Lifting Bail Assembly (Option)..... 36-37
Engine Service Parts 38-39

NOTICE
Part numbers are subject to change without notice.

EXPLANATION OF CODE IN REMARKS COLUMN

The following section explains the different symbols and remarks used in the Parts section of this manual. Use the help numbers found on the back page of the manual if there are any questions.

NOTICE

The contents and part numbers listed in the parts section are subject to change without notice. Multiquip does not guarantee the availability of the parts listed.

SAMPLE PARTS LIST

NO.	PART NO.	PART NAME
QTY.		REMARKS
1	12345	BOLT1INCLUDES ITEMS W/%
2%		WASHER, 1/4 IN.NOT SOLD SEPARATELY
2%	12347	WASHER, 3/8 IN. ...1MQ-45T ONLY
3	12348	HOSEA/R ...MAKE LOCALLY
4	12349	BEARING1S/N 2345B AND ABOVE

NO. Column

Unique Symbols — All items with same unique symbol (@, #, +, %, or >) in the number column belong to the same assembly or kit, which is indicated by a note in the “Remarks” column.

Duplicate Item Numbers — Duplicate numbers indicate multiple part numbers, which are in effect for the same general item, such as different size saw blade guards in use or a part that has been updated on newer versions of the same machine.

NOTICE

When ordering a part that has more than one item number listed, check the remarks column for help in determining the proper part to order.

PART NO. Column

Numbers Used — Part numbers can be indicated by a number, a blank entry, or TBD.

TBD (To Be Determined) is generally used to show a part that has not been assigned a formal part number at the time of publication.

A blank entry generally indicates that the item is not sold separately or is not sold by Multiquip. Other entries will be clarified in the “Remarks” Column.

QTY. Column

Numbers Used — Item quantity can be indicated by a number, a blank entry, or A/R.

A/R (As Required) is generally used for hoses or other parts that are sold in bulk and cut to length.

A blank entry generally indicates that the item is not sold separately. Other entries will be clarified in the “Remarks” Column.

REMARKS Column

Some of the most common notes found in the “Remarks” Column are listed below. Other additional notes needed to describe the item can also be shown.

Assembly/Kit — All items on the parts list with the same unique symbol will be included when this item is purchased.

Indicated by:

“INCLUDES ITEMS W/(unique symbol)”

Serial Number Break — Used to list an effective serial number range where a particular part is used.

Indicated by:

“S/N XXXXX AND BELOW”

“S/N XXXX AND ABOVE”

“S/N XXXX TO S/N XXX”

Specific Model Number Use — Indicates that the part is used only with the specific model number or model number variant listed. It can also be used to show a part is NOT used on a specific model or model number variant.

Indicated by:

“XXXXX ONLY”

“NOT USED ON XXXX”

“Make/Obtain Locally” — Indicates that the part can be purchased at any hardware shop or made out of available items. Examples include battery cables, shims, and certain washers and nuts.

“Not Sold Separately” — Indicates that an item cannot be purchased as a separate item and is either part of an assembly/kit that can be purchased, or is not available for sale through Multiquip.

SUGGESTED SPARE PARTS

HDA-SERIES WALK-BEHIND TROWELS

1 to 3 Units

Qty.	P/N	Description
1	20478	GRIP, LEFT
1	20463	GRIP, RIGHT
2	20856	SAFETY SWITCH
1	20285	CABLE, STANDARD HANDLE
1	20297	CABLE, QUICK-PITCH
1	21243	THROTTLE CABLE
4	11032	BUSHING, TROWEL ARM
4	1162 A	LUBE CAP
4	1167 A	SCREW
4	1456	NUT
4	1875	WASHER
4	1322	SCREW
1	2618	GASKET KIT
1	2619	BEARING KIT
4	1247	RUBBER GROMMET
4	1245	SPACER
1	2827-1	ARM, TROWEL
4	0261	BELT, A-31 GATES, 11HP
2	11537	BELT, HOFFCO-COMET, 13HP
1	10968	THRUST COLLAR KIT

HONDA GX340K1QA2 GASOLINE ENGINE

1 to 3 Units

Qty.	P/N	Description
3	17210ZE3505	ELEMENT, AIR CLEANER
2	17218ZE3505	FILTER, OUTER
1	17672ZE2W01	FILTER, FUEL
1	28462ZE3W01	ROPE, RECOIL STARTER
2	9807956846	SPARK PLUG
2	17620ZH7023	CAP, FUEL

HONDA GX390K1QA2 GASOLINE ENGINE

1 to 3 Units

Qty.	P/N	Description
3	17210ZE3505	ELEMENT, AIR CLEANER
2	17218ZE3505	FILTER, OUTER
1	17672ZE2W01	FILTER, FUEL
1	28462ZV7003	ROPE, RECOIL STARTER
2	9807955846	SPARK PLUG
2	17620ZH7023	CAP, FUEL

NOTICE

Part numbers on this Suggested Spare Parts list may supersede/replace the part numbers shown in the following parts lists.

NAMEPLATE AND DECALS

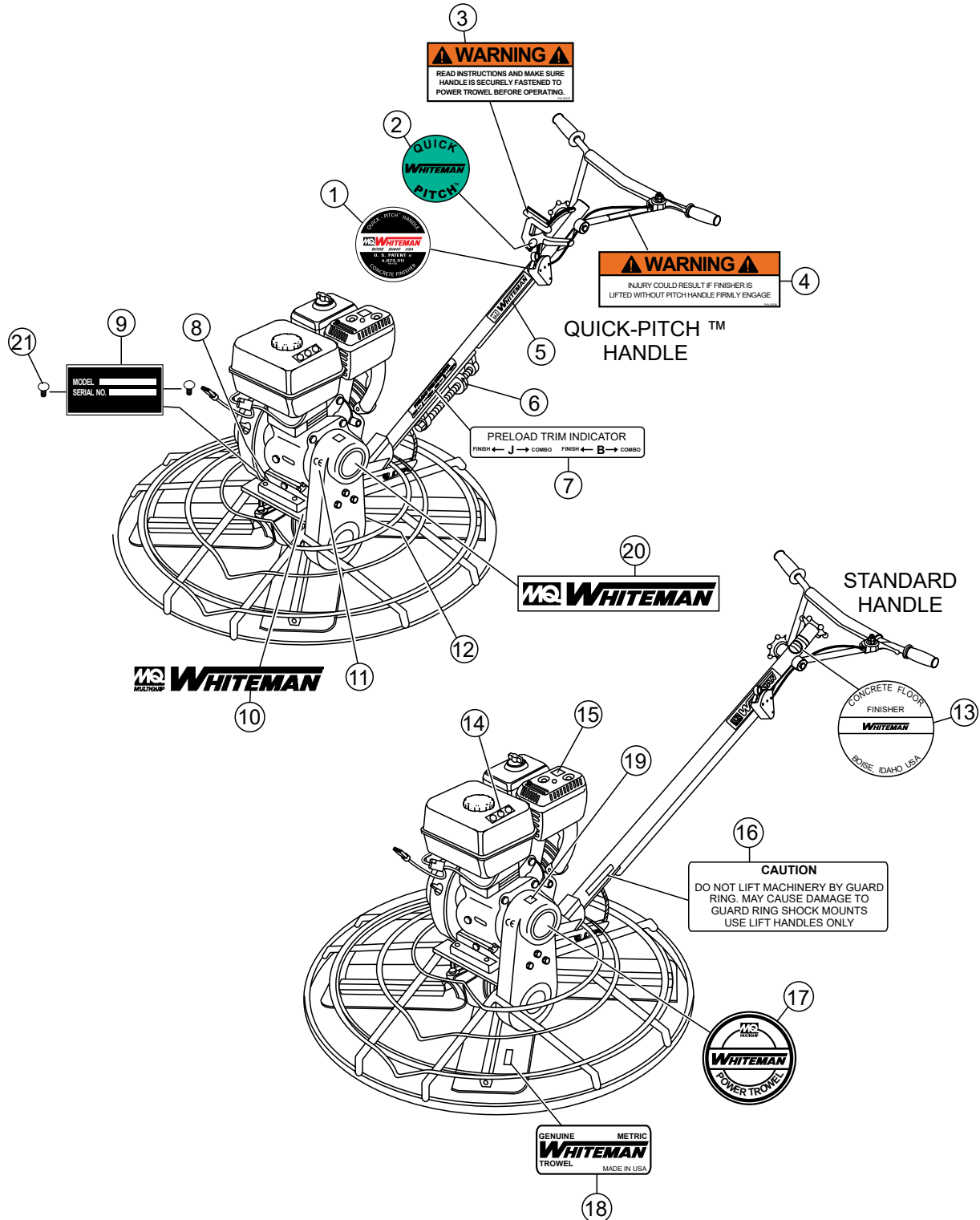

NAMEPLATE AND DECALS

<u>NO.</u>	<u>PART NO.</u>	<u>PART NAME</u>	<u>QTY.</u>	<u>REMARKS</u>
1	1758	DECAL: QUICK-PITCH HANDLE	1	
2	12405	DECAL: QUICK-PITCH HANDLE INSERT	2	
3	20527	DECAL: QUICK-PITCH WARNING	1	
4	20526	DECAL: QUICK-PITCH LATCH WARNING	1	
5	2942	DECAL: MQ WHITEMAN 13"	1	
6	1736	DECAL: ARROWS	1	
7	1735	DECAL: PRE-LOAD INDICATOR	1	
8	11246	DECAL: OIL CHECK.....	1.....	PART OF DECAL KIT P/N 12620
9		NAMEPLATE	1.....	CONTACT MULTIQUIP PARTS DEPT.
10	1940	DECAL: MQ WHITEMAN (SMALL)	1	
11	11092	DECAL: CE	1	
12	11246	DECAL: GEAR DRIVE.....	1.....	PART OF DECAL KIT P/N 12620
13	1492	DECAL: STANDARD HANDLE (FINISHER)	1	
14	1147	DECAL: HELMET, FOOT AND GLOVE	1.....	PART OF DECAL KIT P/N 12620
15	11246	DECAL: HOT	1.....	PART OF DECAL KIT P/N 12620
16	1261	DECAL: DO NOT LIFT	1	
17	1848	DECAL: POWER TROWEL	1	
18	2938	DECAL: METRIC	1	
19	11246	DECAL: BELT DRIVE	1.....	PART OF DECAL KIT P/N 12620
20	2423	DECAL: MQ WHITEMAN-ENGINE	1	
21	4014	SCREW, 2-3/16 P-K TYPE U-DRIVE	2	

STANDARD HANDLE ASSY. (OLD STYLE)

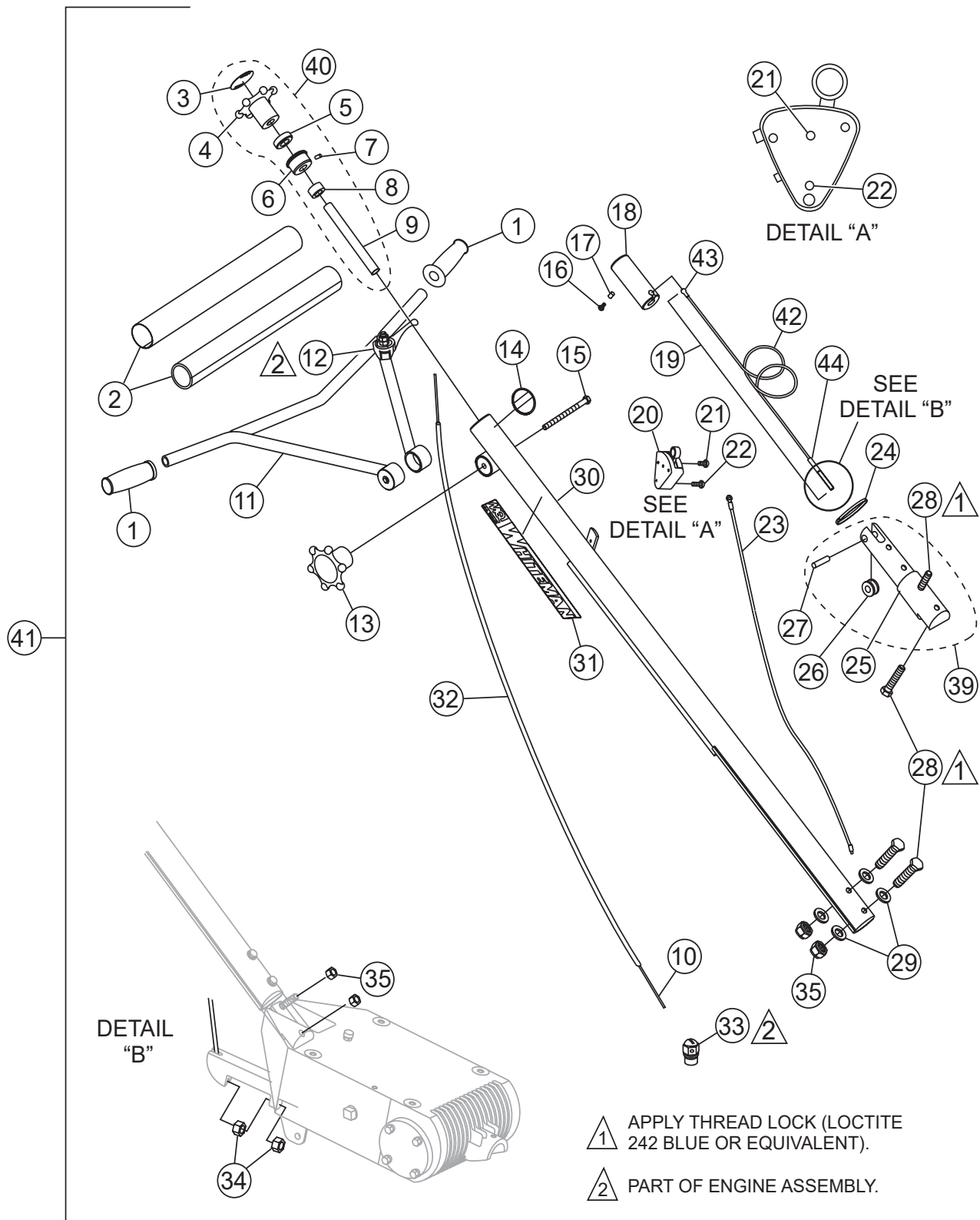

STANDARD HANDLE ASSY. (OLD STYLE)

<u>NO.</u>	<u>PART NO.</u>	<u>PART NAME</u>	<u>QTY.</u>	<u>REMARKS</u>
1	22762	GRIP, HANDLE	2	
2	20774	COVER, PAD HANDLE	1	
3	20818	DECAL, STD. PITCH.....	1	NO LONGER AVAILABLE
4\$	20817	WHEEL, HAND HANDLE	1	
5\$	0281	BEARING, THRUST, NICE 607	1	
6\$	20282	BEARING, TROWEL CONTROL	1	
7\$	0122 C	SCREW, SHS 3/8"-16 X 1/2"	1	
8\$	3615	COLLAR, SET 3/4" ID	1	
9\$	1478	SHAFT, TROWEL CONTROL	1	
10	21172	CABLE, THROTTLE	1	
11	12556	HANDLE, ADJUSTABLE	1	
12	22732	THROTTLE LEVER ASSY.	1	
13	20439	WHEEL ASSY., HAND	1	
14	1492	DECAL, CUSTOM 2-1/2" CHROME	1	
15	20438	SCREW, HHC 3/8"-16 X 5"	1	
16	0786	SCREW, BHC 1/4"-20 X 3/8" NYL PATCH, NP	1	
17	0786 A	SPACER, .360 X 17/64" X 1/8"L	1	
18	20287	SLIDE BLOCK TROWEL CONTROL	1	
19	20285	CABLE ASSY., LENGTH 48.29" STD FINISHER.....	1	INCLUDES ITEMS W/@
20	20856	SWITCH ASSY., SAFETY STOP.....	1	INCLUDES ITEMS W/%
21%	1602	SCREW, RHM 10-24 X 3/8"	1	
22	20988	SCREW, FHSC PHILLIPS 8-32 X 1-1/4"	1	
23	20514	WIRE ASSY., SAFETY STOP SWITCH	1	
24	1662	TIE, CABLE TY-RAP, BLACK	1	
25#	20460	BLOCK, SUPPORT	1	
26#	1118	PULLEY, SUPPORT BLOCK	1	
27#	20279	PIN, SUPPORT BLOCK 3/8" X 1.59	1	
28	0169	SCREW, HHC 3/8"-16 X 3	4	
29	10136	WASHER, FLAT 3/8" SAE	4	
30	12567	HANDLE, STD.	1	
31	2942	DECAL, MQ WHITEMAN, 13"	1	
32	21173	HOUSING, CABLE 74"	1	
33	20845	SWIVEL, THROTTLE CABLE	1	
34	1116	NUT, BRASS JAM 5/16"-18	2	
35	10133	NUT, NYLOC 3/8"-16	3	
39	20461	BLOCK, CABLE ASSY.....	1	INCLUDES ITEMS W/#
40	20819	HAND WHEEL ASSY., PITCH CONTROL.....	1	INCLUDES ITEMS W/\$
41		HANDLE ASSY., STD FINISHERS.....	1	NO LONGER AVAILABLE CONTACT UNIT SALES DEPT.
42@	20301	CABLE ASSY., 48.29" X 5/32" DIA.....	1	NOT SOLD SEPARATELY
43@	20421	CLEVIS, BALL END CONTROL CABLE.....	1	NOT SOLD SEPARATELY
44@	A8638	END-BOLT, CONTROL CABLE	1	

STANDARD HANDLE ASSY. (NEW STYLE)

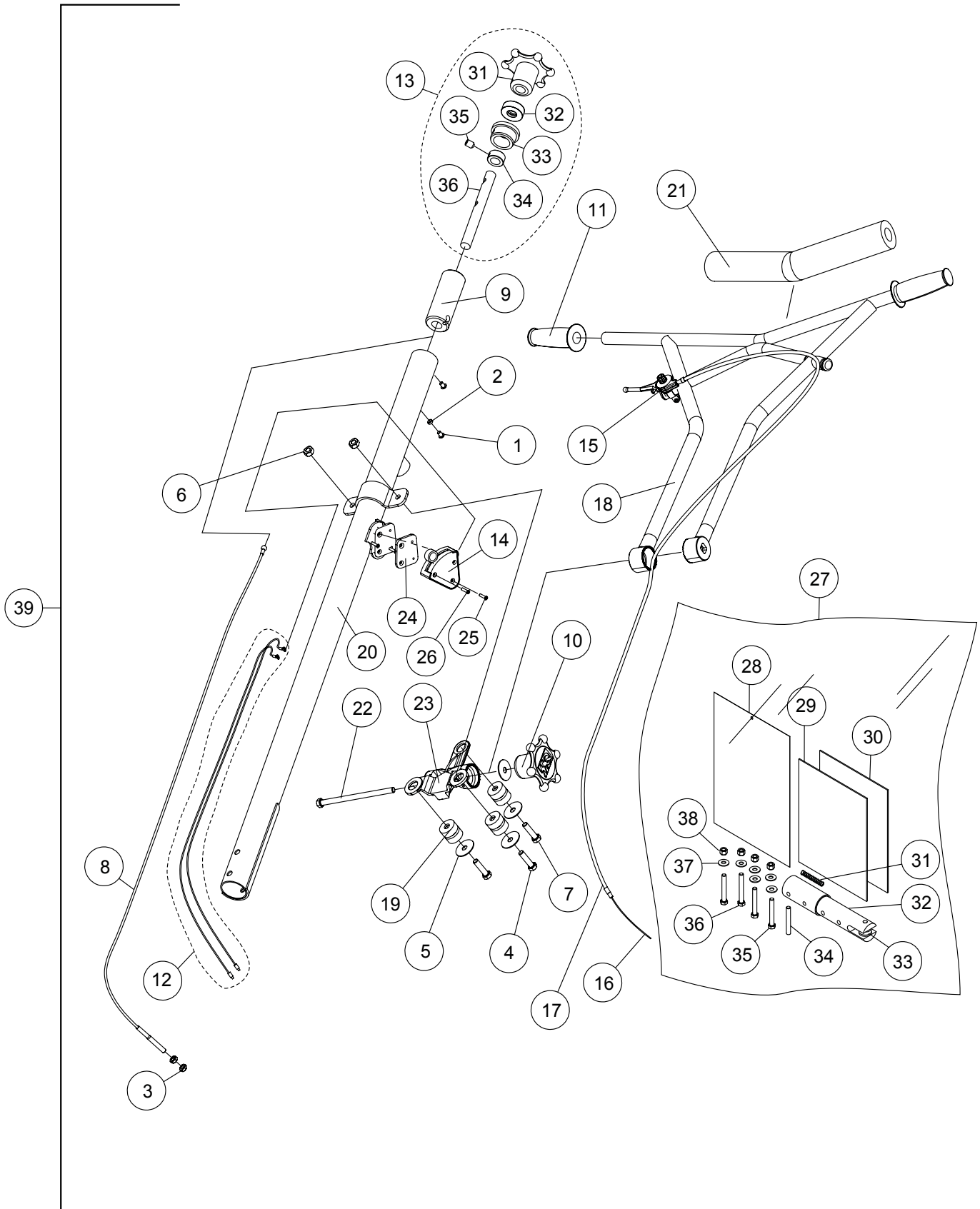

STANDARD HANDLE ASSY. (NEW STYLE)

<u>NO.</u>	<u>PART NO.</u>	<u>PART NAME</u>	<u>QTY.</u>	<u>REMARKS</u>
1%	0786	SCREW, BHC 1/4"-20 X 3/8" NYL PATCH , NP	2	
2%	0786 A	SPACER, SLIDE BLOCK GUIDE	1	
3%	1116	NUT, BRASS JAM 5/16"-18	2	
4%	1665	SCREW, HHC 3/8"-16 X 2"	2	
5%	3233	WASHER, FENDER, 1.5 OD X 3/8" ID	4	
6%	10133	NUT, NYLOC 3/8"-16	2	
7%	9154	SCREW, HHC 3/8"-16 X 1-3/4"	1	
8%	20285	CABLE, CONTROL	1	
9%	20287	SLIDE BLOCK, TROWEL CONTROL	1	
10%	20439	WHEEL ASSY., HAND	1	
11%	22762	GRIP, HANDLE	2	
12%	21953	HARNESS, CENTRIFUGAL SWITCH, 45.25" LONG	1	
13%	20819	HAND WHEEL ASSY., PITCH CONTROL	1	INCLUDES ITEMS W/\$
14%	20856	SWITCH ASSY., KILL	1	
15%	22732	THROTTLE LEVER ASSY.	1	
16%	21172	CABLE, THROTTLE 68"	1	
17%	21173	HOUSING, MAGURA THROTTLE CABLES	1	
18%	22055	HANDLE WA, VIBRATION CONTROL	1	
19%	22059	ISOLATOR, VIBRATION 80 DUROMETER	3	
20%	22095	HANDLE, STD VC W/A PAINTED	1	
21%	22166	COVER,VIBE CONTROL HANDLE PAD	1	
22%	22167	SCREW, HHC 3/8"-16 X 6.5" GRD 5	1	
23%	22206	CHASSIS, CAST VIBRATION ISOLATOR	1	
24%	22256	BRACKET, HD KILL SWITCH MOUNT	1	
25%	22263	SCREW, PHILLIPS HEAD MACHINE 8-32 X .75	1	
26%	22262	SCREW, FHMP 10-24 X 3/4"	1	
27%	22226	KIT, INSTALLATION VIBE CONTROL HANDLE	1	INCLUDES ITEMS W/@
28@%	2764	BAG, PARTS	1	
29@%	22227	WBT-HD BLOCK INSTALLATION INSTRUCTIONS	1	
30@%	20485	INSTRUCTION, 2" HANDLE/THROTTLE ASSY.	1	
31@%	21746	SPRING, 0.42 OD. X 2.5L	1	
32@%	20460	BLOCK, SUPPORT	1	
33@%	1118	PULLEY, PITCH CABLE ASSY.	1	
34@%	20279	PIN, SUPPORT BLOCK 3/8" X 1.59	1	
35@%	1121	SCREW, HHC 3/8"-16 X 2-3/4"	3	
36@%	20473	SCREW, HHC 3/8"-16 X 3" FULL THREAD GRD 5	1	
37@%	10136	WASHER, FLAT SAE 3/8"	6	
38@%	10133	NUT, NYLOC 3/8"-16	4	
39	SXHD	HANDLE ASSY., SXH HD	1	INCLUDES ITEMS W/%

QUICK PITCH HANDLE ASSY. (OLD STYLE)

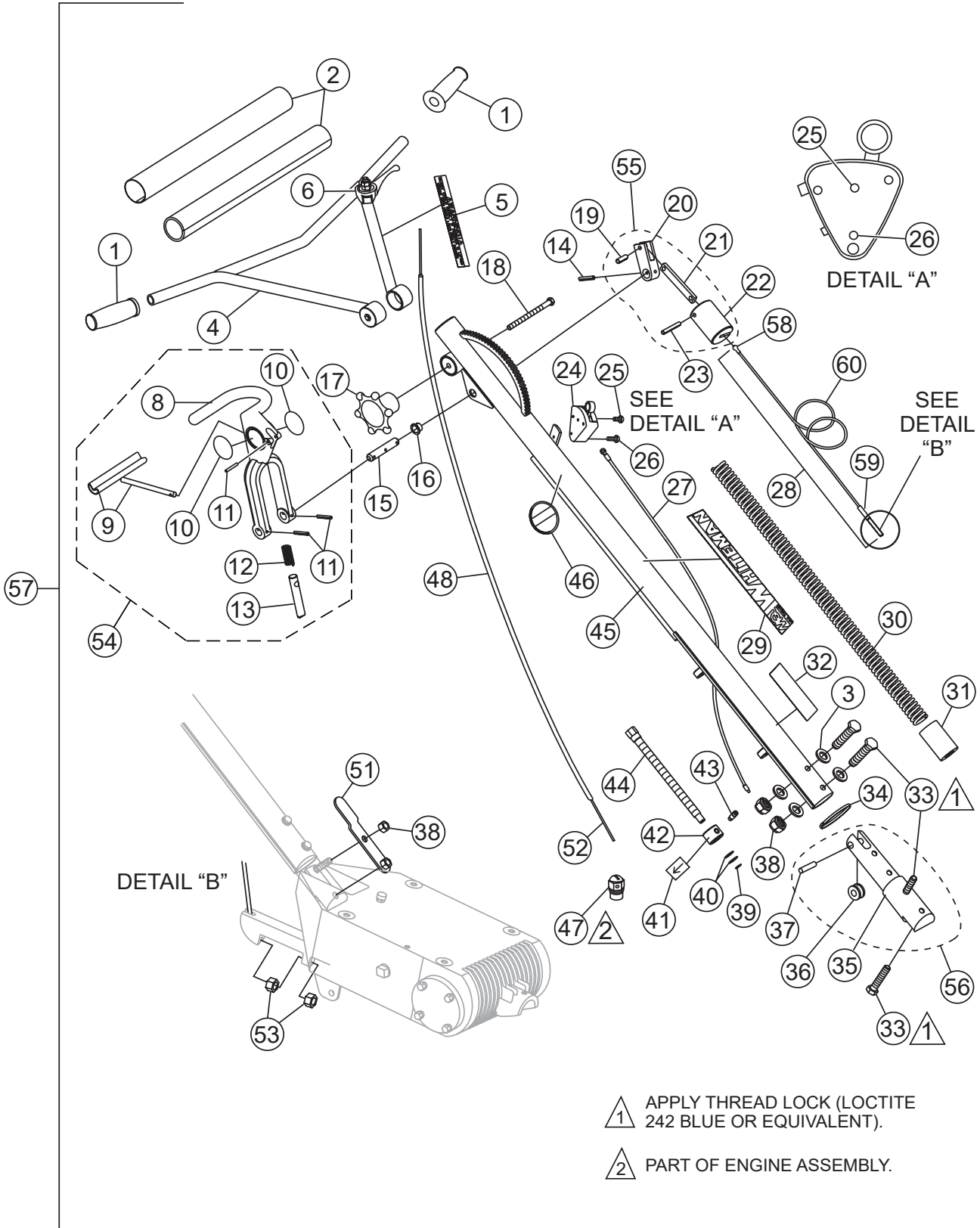

QUICK PITCH HANDLE ASSY. (OLD STYLE)

<u>NO.</u>	<u>PART NO.</u>	<u>PART NAME</u>	<u>QTY.</u>	<u>REMARKS</u>
1	22762	GRIP, HANDLE	2	
2	20774	COVER, PAD HANDLE	1	
3	10136	WASHER, FLAT 3/8" SAE	4	
4	12556	HANDLE, ADJUSTABLE	1	
5	20526	DECAL, LATCH WARNING	1	
6	22732	THROTTLE	1	
7	20527	DECAL, Q.P. WARNING	1	
8\$	20389	HANDLE, Q.P.	1	
9\$	1746	TRIGGER, Q.P. CHROMED	1	
10\$	12405	DECAL, WHITEMAN Q.P.	2	
11\$	1729	PIN, ROLL 3/16" X 1-1/4"	3	
12\$	1706	SPRING, ENCLOSED Q.P. CLAMP	1	
13\$	20437	PIN, Q.P. LATCH	1	
14	4568	PIN, ROLL 3/16" X 1"	1	
15	1711	SHAFT, CONTROL Q.P.	1	
16	1719	BUSHING, PIVOT PLATE	1	
17	20439	WHEEL ASSY., HAND	1	
18	20438	SCREW, HHC 3/8"-16 X 5"	1	
19+	1731	PIN, ROLL 1/4" X 3/4"	1	
20+	20443	ARM, SLIDE CONTROL	1	
21+	1709	CONNECTOR, Q.P. CONTROL ARM	1	
22+	20269	LINKAGE, Q.P. CONTROL	1	
23+	20276	PIN, ROLL 1/4" X 1-3/4"	1	
24	20856	SWITCH ASSY., SAFETY STOP	1	INCLUDES ITEMS W/◆
25◆	1602	SCREW, RHM 10-24 X 3/8"	1	
26	20988	SCREW, FHSC PHILLIPS 8-32 X 1-1/4"	1	
27	20514	WIRE ASSY., SAFETY STOP SWITCH	1	
28	20297	CABLE ASSY., Q.P. CONTROL, 45"	1	INCLUDES ITEMS W/◇
29	2942	DECAL, MQ WHITEMAN, 13"	1	
30	1715	SPRING, COUNTER BALANCE	1	
31	20270	BLOCK, Q.P. ADJUSTMENT	1	
32	1735	DECAL, PRELOAD TRIM INDICATOR	1	
33	0169	SCREW, HHC 3/8"-16 X 3"	4	
34	1662	TIE, TY-RAP BLACK CABLE	1	
35#	20460	BLOCK, SUPPORT	1	
36#	1118	PULLEY, SUPPORT BLOCK	1	
37#	20279	PIN, SUPPORT BLOCK 3/8" X 1.59	1	
38	10133	NUT, NYLOC 3/8"-16	3	
39	1737	SNAP RING, TRUARC #5100-50	1	
40	1733	WASHER, 1/2" X 1/32" HARDENED	2	

QUICK PITCH HANDLE ASSY. (OLD STYLE)

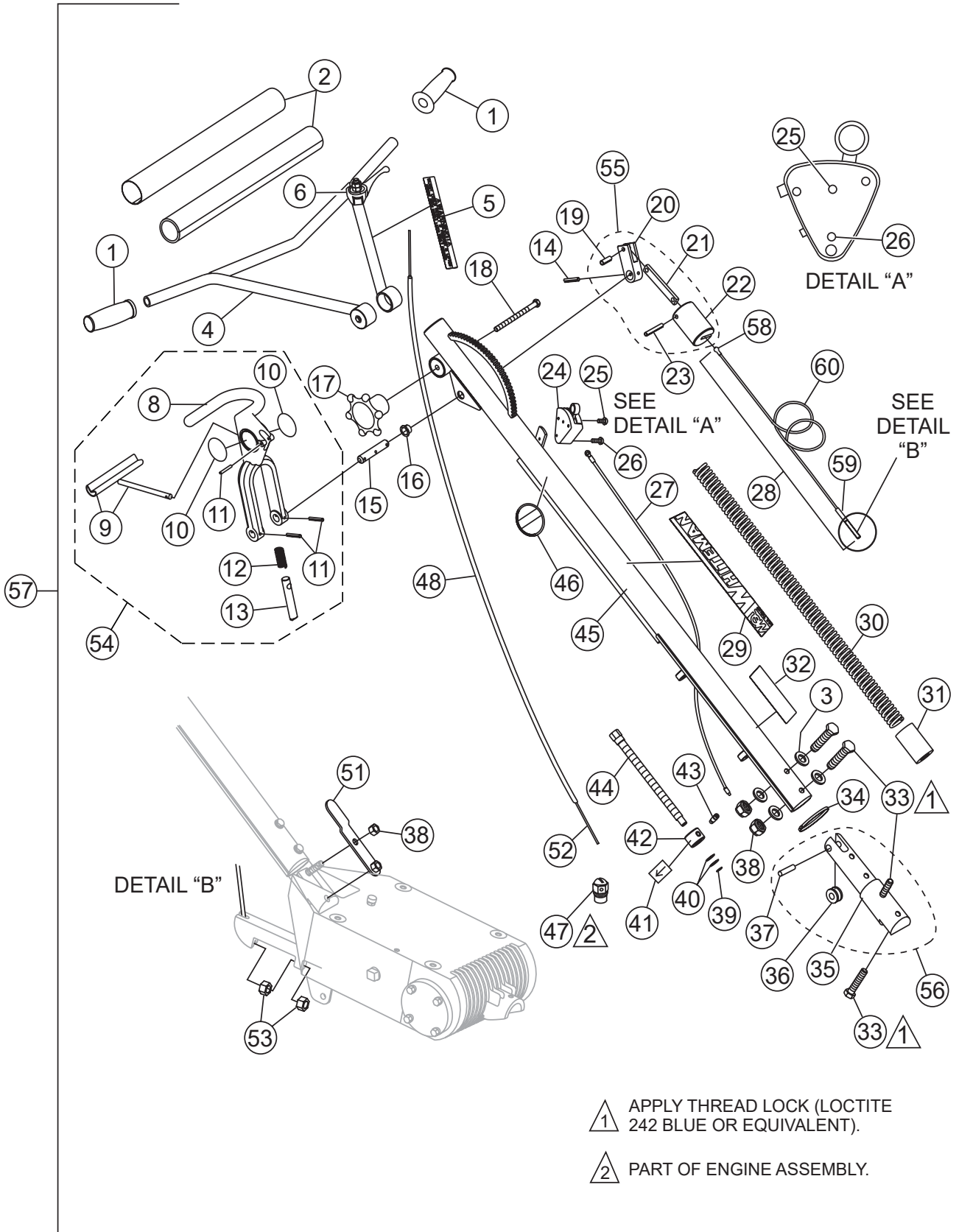

QUICK PITCH HANDLE ASSY. (OLD STYLE)

<u>NO.</u>	<u>PART NO.</u>	<u>PART NAME</u>	<u>QTY.</u>	<u>REMARKS</u>
41%	1736	DECAL, ARROW	1	
42%	1718	NUT, Q.P. TRIM CONTROL ADJUST	1	
43%	1732	BOLT, STRIPPER 3/8" X 1/2"	1	
44%	1717	SCREW, Q.P. TRIM ADJUSTMENT	1	
45%	12642	TUBE, MAIN HANDLE	1	
46%	1758	DECAL, PATENT Q.P.	1	
47%	20845	SWIVEL, ENGINE THROTTLE CABLE	1	
48%	21173	HOUSING, THROTTLE CABLE 74"	1	
51%	20392	BRACKET, LIFT TUBE	1	
52%	21172	CABLE, THROTTLE	1	
53%	1116	NUT, BRASS JAM 5/16"-18	2	
54%	20390	TRIGGER, Q.P. ASSY.....	1	INCLUDES ITEMS W/\$
55%	20293	LINKAGE, Q.P. CONTROL ASSY.....	1	INCLUDES ITEMS W/+
56%	20461	BLOCK, CABLE ASSY.....	1	INCLUDES ITEMS W/#
57		HANDLE ASSY., MAIN	1	NO LONGER AVAILABLE INCLUDES ITEMS W/% CONTACT UNIT SALES DEPT.
58%◇	20421	CLEVIS, BALL END CONTROL CABLE.....	1	NOT SOLD SEPARATELY
59%◇	A8638	END-BOLT, CONTROL CABLE	1	NOT SOLD SEPARATELY
60%◇	20271	CABLE, CNTL 5/32".....	1	NOT SOLD SEPARATELY

QUICK PITCH HANDLE ASSY. (NEW STYLE)

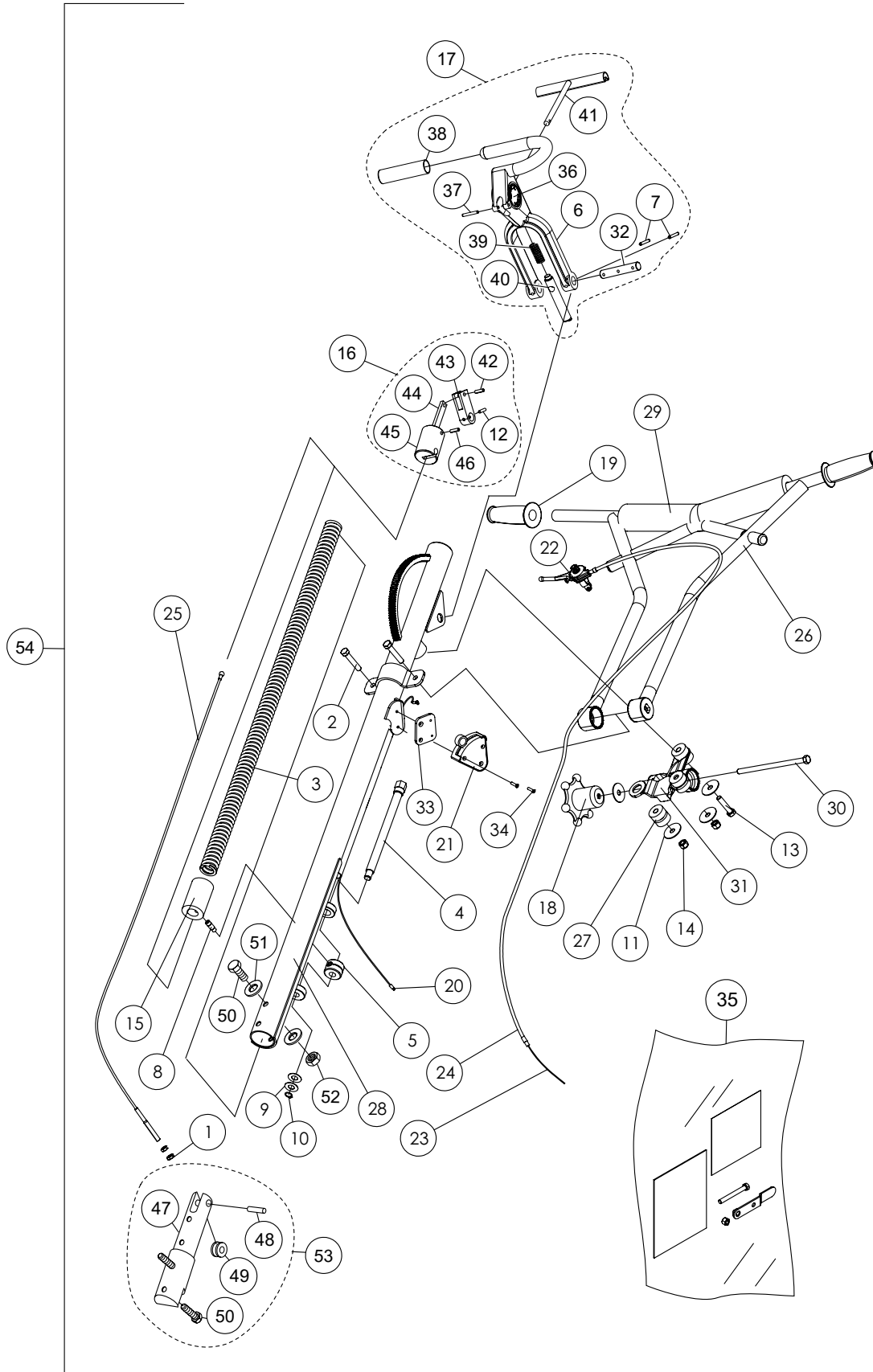

QUICK PITCH HANDLE ASSY. (NEW STYLE)

<u>NO.</u>	<u>PART NO.</u>	<u>PART NAME</u>	<u>QTY.</u>	<u>REMARKS</u>
1%	1116	NUT, BRASS JAM 5/16"-18	2	
2%	1665	SCREW, HHC 3/8"-16 X 2"	2	
3%	1715	SPRING, COUNTER BALANCE	1	
4%	1717	SCREW, Q.P. TRIM ADJUSTMENT W/A	1	
5%	1718	NUT, QP TRIM CONTROL ADJUSTMENT	1	
6%@	20389	HANDLE, Q.P.	1	
7%@	1729	PIN, ROLL 3/16" X 1-1/4"	2	
8%	1732	Q.P. ADJUSTMENT PIN	1	
9%	1733	WASHER, 1/2" X 1/32", AN960-816L	2	
10%	1737	RING, SNAP, TRUARC 5100-50	1	
11%	3233	WASHER, FENDER, 1-1/2" OD X 3/8" ID	4	
12%#	4568	PIN, ROLL 3/16" X 1"	1	
13%	9154	SCREW, HHC 3/8"-16 X 1-3/4"	1	
14%	10133	NUT, NYLOC 3/8"-16	2	
15%	20270	Q.P. ADJUSTMENT BLOCK	1	
16%	20293	LINKAGE Q.P. CONTROL	1	INCLUDES ITEMS W/#
17%	20390	TRIGGER, Q.P. ASSEMBLY	1	INCLUDES ITEMS W/@
18%	20439	WHEEL ASSY. , HAND	1	
19%	22762	GRIP, HANDLE	2	
20%	20514	WIRE ASSY., KILL SWITCH	1	
21%	20856	SWITCH ASSY., KILL	1	
22%	22732	THROTTLE, BICYCLE FINISHER HANDLES	1	
23%	21172	CABLE, THROTTLE 68"	1	
24%	21173	HOUSING, MAGURA THROTTLE CABLES	1	
25%	20297	CABLE ASSY., LENGTH 45", JB, HD AND Q.P.	1	
26%	22055	HANDLE WA, VIBRATION CONTROL	1	
27%	22059	ISOLATOR, VIBRATION 80 DUROMETER SHORE A	3	
28%	22060	MAIN HANDLE WA, QUICK PITCH VIBE CONTROL	1	
29%	22166	COVER, VIBE CONTROL HANDLE PAD	1	
30%	22167	SCREW, HHC 3/8"-16 X 6.5" GRD 5	1	
31%	22206	CHASSIS, CAST VIBRATION ISOLATOR	1	
32%@	1711	SHAFT, CONTROL Q.P.	1	
33%	22256	BRACKET, HD KILLSWITCH MOUNT	1	
34%	22263	SCREW, PHILLIPS HEAD MACHINE 8-32 X .75	2	
35%	22226	KIT, INSTALLATION VIBE CONTROL HANDLE	1	INCLUDES ITEMS W/\$

QUICK PITCH HANDLE ASSY. (NEW STYLE)

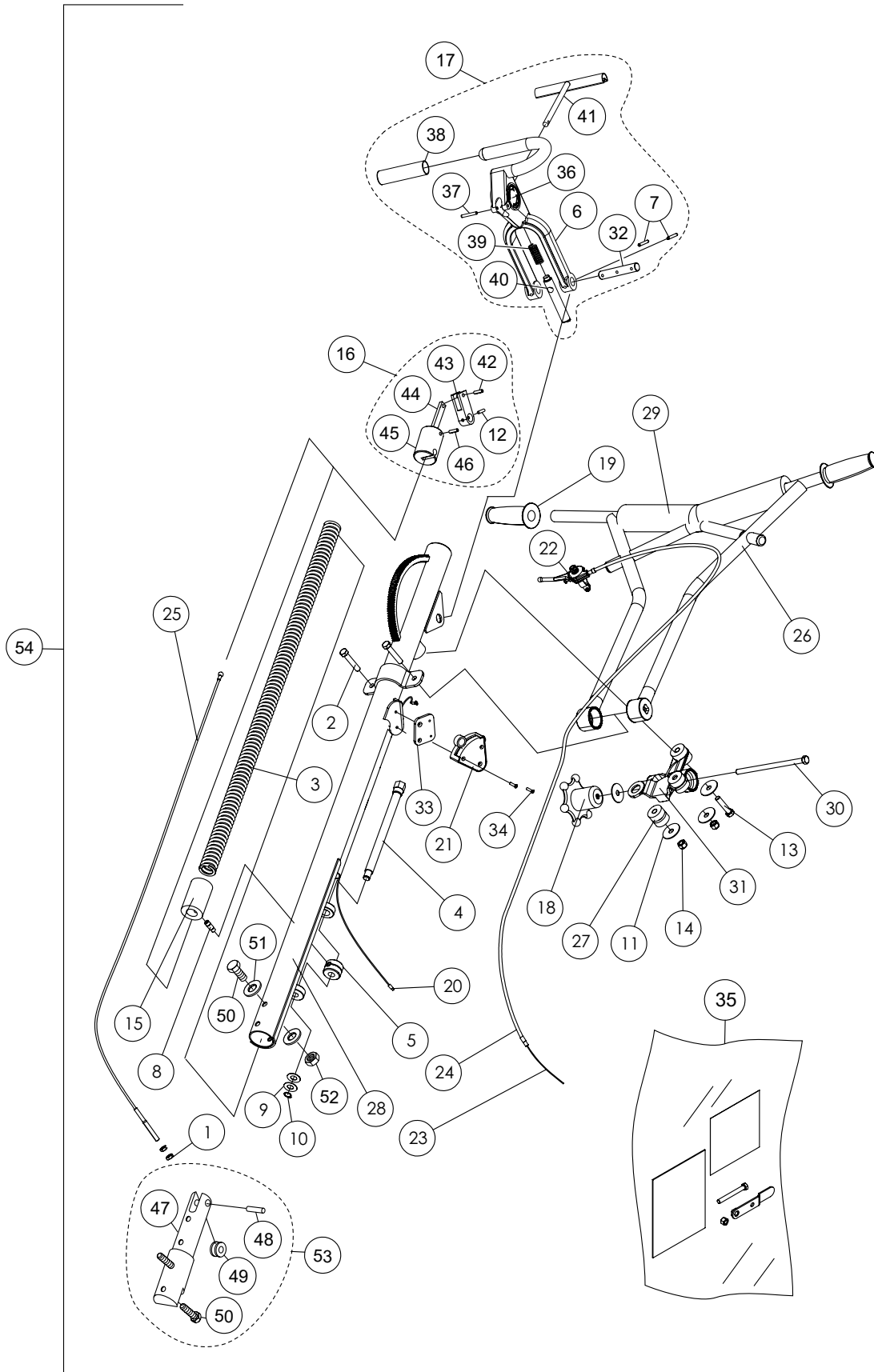

QUICK PITCH HANDLE ASSY. (NEW STYLE)

<u>NO.</u>	<u>PART NO.</u>	<u>PART NAME</u>	<u>QTY.</u>	<u>REMARKS</u>
36%@	12405	DECAL, WHITEMAN QUICK PITCH	2	
37%@	1729	PIN, ROLL 3/16" X 1-1/4"	1	
38%@	1724	GRIP, HANDLE	1	
39%@	1706	SPRING, COMPRESSION	1	
40%@	20437	PIN, QP LATCH	1	
41%@	1746	TRIGGER, QP	1	
42%#	1731	PIN, ROLL 1/4" X 3/4"	1	
43%#	20443	ARM, SLIDE CONTROL	1	
44%#	1709	QP DOGBONE	1	
45%#	20269	BLOCK, CABLE SLIDE	1	
46%#	20276	PIN, ROLL 1/4" X 1-3/4"	1	
47%\$◆	22095	HANDLE, STD. VC W/A PAINTED	1	
48%\$◆	20279	PIN, SUPPORT BLOCK 3/8" X 1.59	1	
49%\$◆	1118	PULLEY, SUPPORT BLOCK	1	
50%\$◆	0169	SCREW, HHC 3/8"-16 X 3"	4	
51%\$	10136	WASHER, FLAT 3/8" SAE	4	
52%\$	10133	NUT, NYLOC 3/8"-16	2	
53%\$	20461	BLOCK, CABLE ASSY.....	1	INCLUDES ITEMS W/◆
54	QXHD	HANDLE ASSY., QUICK PITCH HD.....	1	INCLUDES ITEMS W/%

4-BLADE SPIDER ASSY.

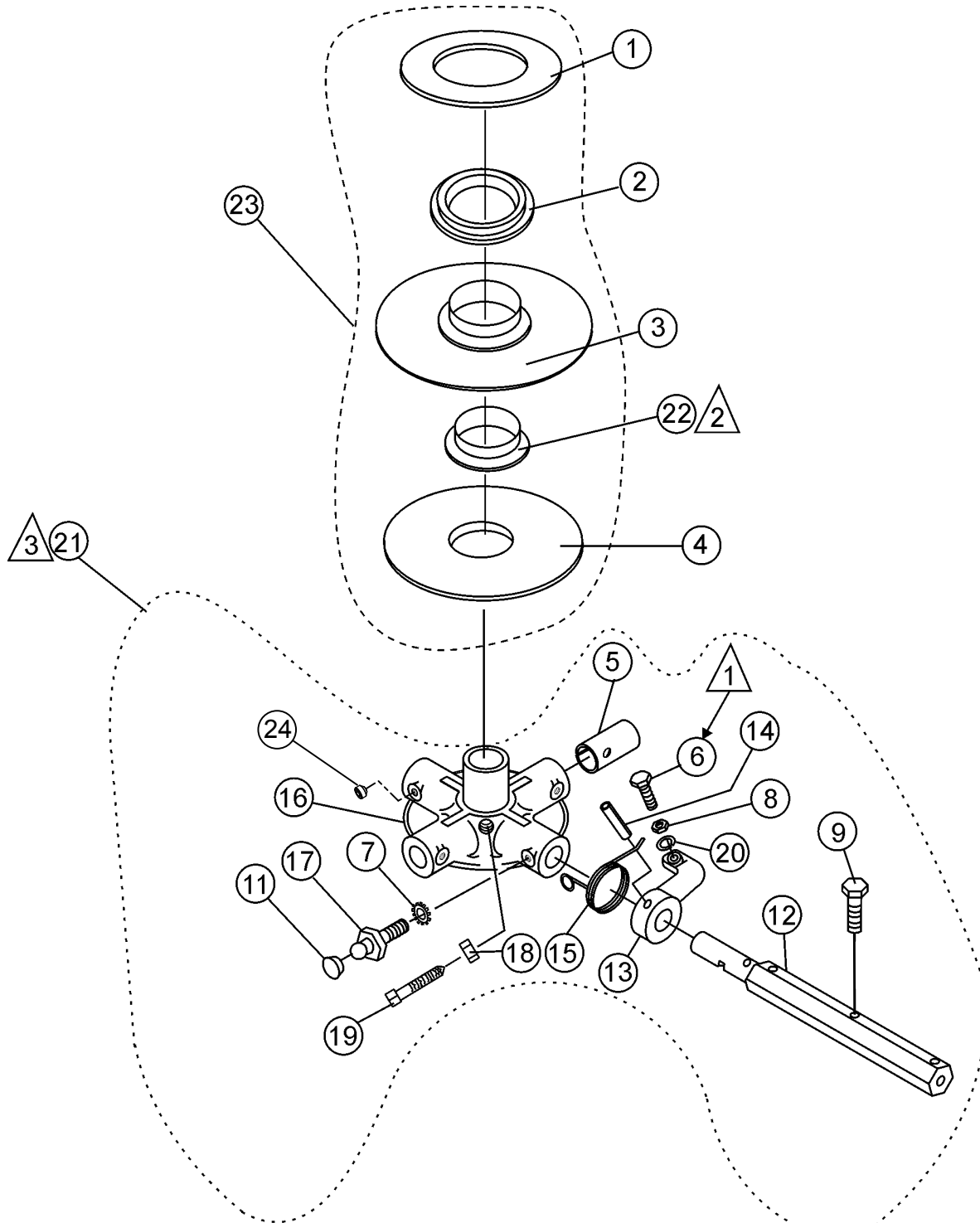

NOTES:

- ① APPLY LOCTITE P/N 1477
- ② INCLUDED WITH ITEM 3 OR CAN BE ORDERED SEPARATELY (P/N 1471).
- ③ SPIDER ASSEMBLY P/N 9150 INCLUDES ALL ITEMS WITHIN OUTLINE.

4-BLADE SPIDER ASSY.

<u>NO.</u>	<u>PART NO.</u>	<u>PART NAME</u>	<u>QTY.</u>	<u>REMARKS</u>
1@	12208	WEAR RING	1	
2@	12778	FLANGE BEARING	1	
3@	10816	THRUST COLLAR	1	INCLUDES ITEMS W/#
4@	9009	WEAR LATE	1	
5%	11039	BUSHING	8	
6%	0164 B	RADIUS HEAD 3/8"-16 X 1-1/4"	8	
7%	1875	INT. SHKP. WASHER 3/8"	4	
8%	1876	JAM NUT 3/8"-16	4	
9%	0105	HHCS 5/16"-18 X 1-1/2"	8	
11%	1162 A	LUBRA-CAP	4	
12%	2829-1	ARM, TROWEL	4	
13%	11903-1	TROWEL ARM LEVER	4	
14%	9006	ROLL PIN 5/16" X 1-3/4"	4	
15%	9111	SPRING (RIGHT HAND)	4	
16%	11787	SPIDER PLATE KIT	1	
17%	1322	RETAINING SCREW ASSY.	4	
18%	1456	HEX NUT 3/8"-16	1	
19%	12097	SCREW, 3/8"-16 X 1-3/4" CONE GRD 8	1	
20%	0166 A	LOCK WASHER 3/8"	4	
21	9150	SPIDER PLATE ASSY.....	1	INCLUDES ITEMS W/%
22@#	1471	THRUST COLLAR BUSHING	1	
23	10969	THRUST BEARING KIT	1	INCLUDES ITEMS W@
24	11602	SCREW, SHS 3/8"-16 X 1/4"	4	
25	23649	KIT, BOLT SAE BLADE FINISHER HD	1	

GEARBOX ASSY.

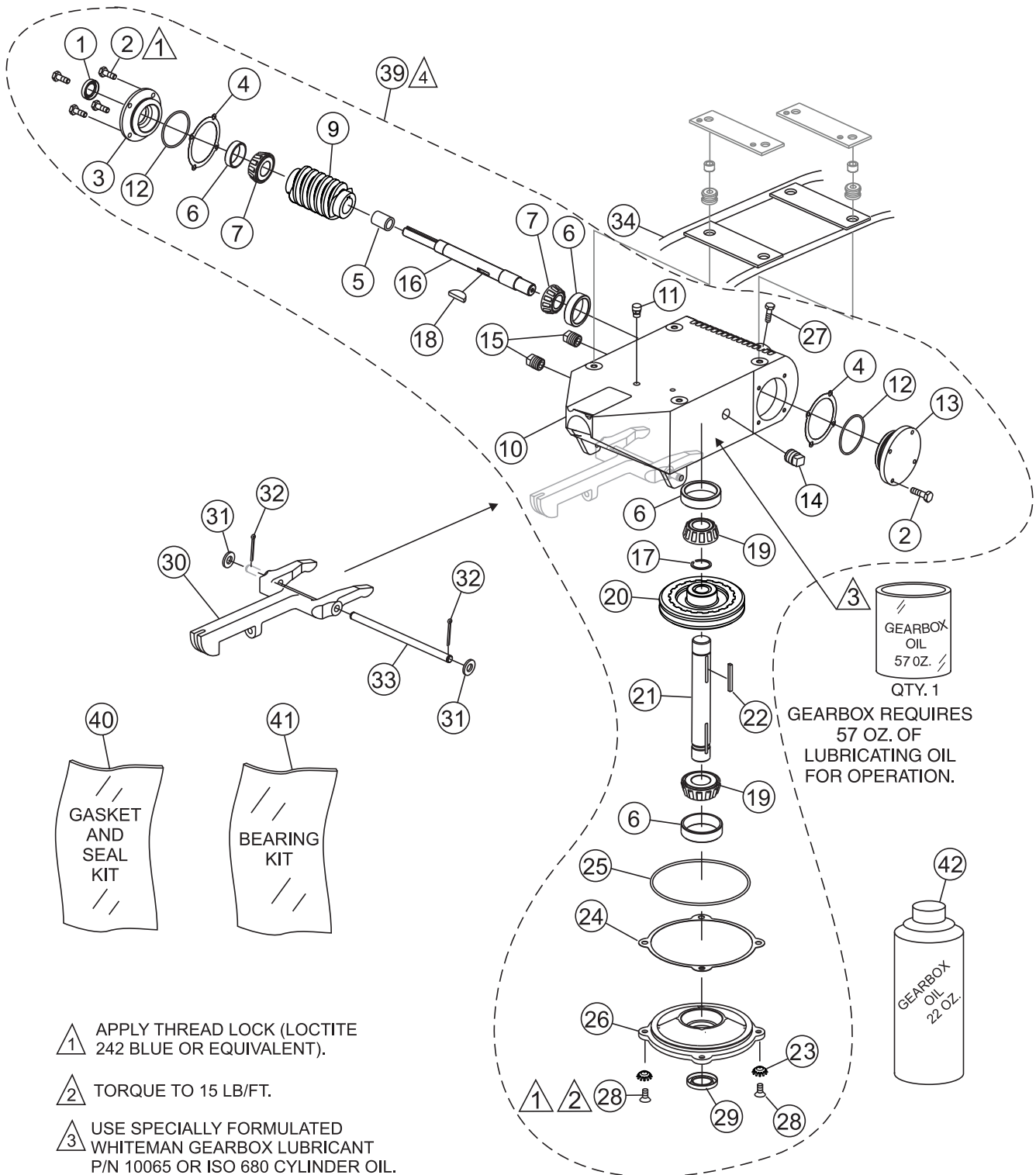

- 1 △ APPLY THREAD LOCK (LOCTITE 242 BLUE OR EQUIVALENT).
- 2 △ TORQUE TO 15 LB/FT.
- 3 △ USE SPECIALLY FORMULATED WHITEMAN GEARBOX LUBRICANT P/N 10065 OR ISO 680 CYLINDER OIL.
- 4 △ GEARBOX ASSEMBLY, ITEM 39 INCLUDES ITEMS WITHIN DASHED LINES, EXCEPT ITEMS 12 AND 23.

GEARBOX ASSY.

<u>NO.</u>	<u>PART NO.</u>	<u>PART NAME</u>	<u>QTY.</u>	<u>REMARKS</u>
1%\$	12909	SEAL, OIL TCM 10172VTB-H	1	
2%	2295	SCREW, HHC 1/4"-20 X 7/8"	8	
3%	9047	FLANGE, COUNTERSHAFT	1	
4%\$	9048	GASKET	2	
5%\$	12583	SPACER, 1-3/8" OD X 1" ID X 1-3/16"	1	
6%#	0232 A	BEARING, CUP, TIMKEN 1932	4	
7%#	9045	BEARING, CONE, TIMKEN 1986	2	
8%	1580	KEY, SQUARE	1	
9%	12908	GEAR, WORM RH	1	
10%	20540	CASE, HD GEARBOX 2" HANDLE	1	
11%	1132	VENT, AIR	1	
12	2309	O-RING, 2-13/16" VITON	2	
13%	9046	CAP, END	1	
14%	21033	SIGHT GLASS, 3/4 NPT STEEL	1	
15%	0121 A	FITTING, PLUG 3/8" MP SQ. HEAD	3	
16%	12944	SHAFT, GEARBOX (13HP HONDA)	1	
16%	12943	SHAFT, GEARBOX (11HP HONDA)	1	
17%	1138	RING, SNAP, TRUARC 5100-112	1	
18%#	1139	KEY, WOODRUFF	1	
19%#	0232	BEARING, CONE TIMKEN 1985	2	
20%	9181	GEAR, WORM, RH	1	
21%	9179	SHAFT, MAIN OUTPUT HD 48	1	
22%	9180	KEY, 5/16" X 2-1/4" SQ.	1	
23%	10235	WASHER, LOCK 5/16 EXT. TOOTH CSKINK	4	
24%\$	9037	SHIM, OUTPUT	1	
25%\$	9038	O-RING, A-257 VITON	1	
26%	9036	COVER, GEARBOX	1	
27%	0400 B	SCREW, HHC 5/16"-18 X 1/2"	1	
28%	20875	SCREW, FHSC 5/16"-18 X 3/4"	4	
29%\$	9041	SEAL, OIL, TCM	1	
30	9027	ARM, YOKE	1	
31	10136	WASHER, FLAT 3/8" SAE	4	
32	0683	PIN, COTTER 3/32"	2	
33	9028	PIN, YOKE	1	
34	7299	STATIONARY GUARD RING	1	
39	20879	GEARBOX ASSY. (11HP HONDA).....	1	INCLUDES ITEMS W/%
39	20882	GEARBOX ASSY. (13HP HONDA).....	1	INCLUDES ITEMS W/%
40	2618	GASKET/SEAL KIT	1	INCLUDES ITEMS W/\$
41	2619	BEARING KIT	1	INCLUDES ITEMS W/#
42	20111	LUBRICANT, GEARBOX, 22 OZ. BOTTLE	1	

ENGINE AND CLUTCH ASSY. (11 HP)

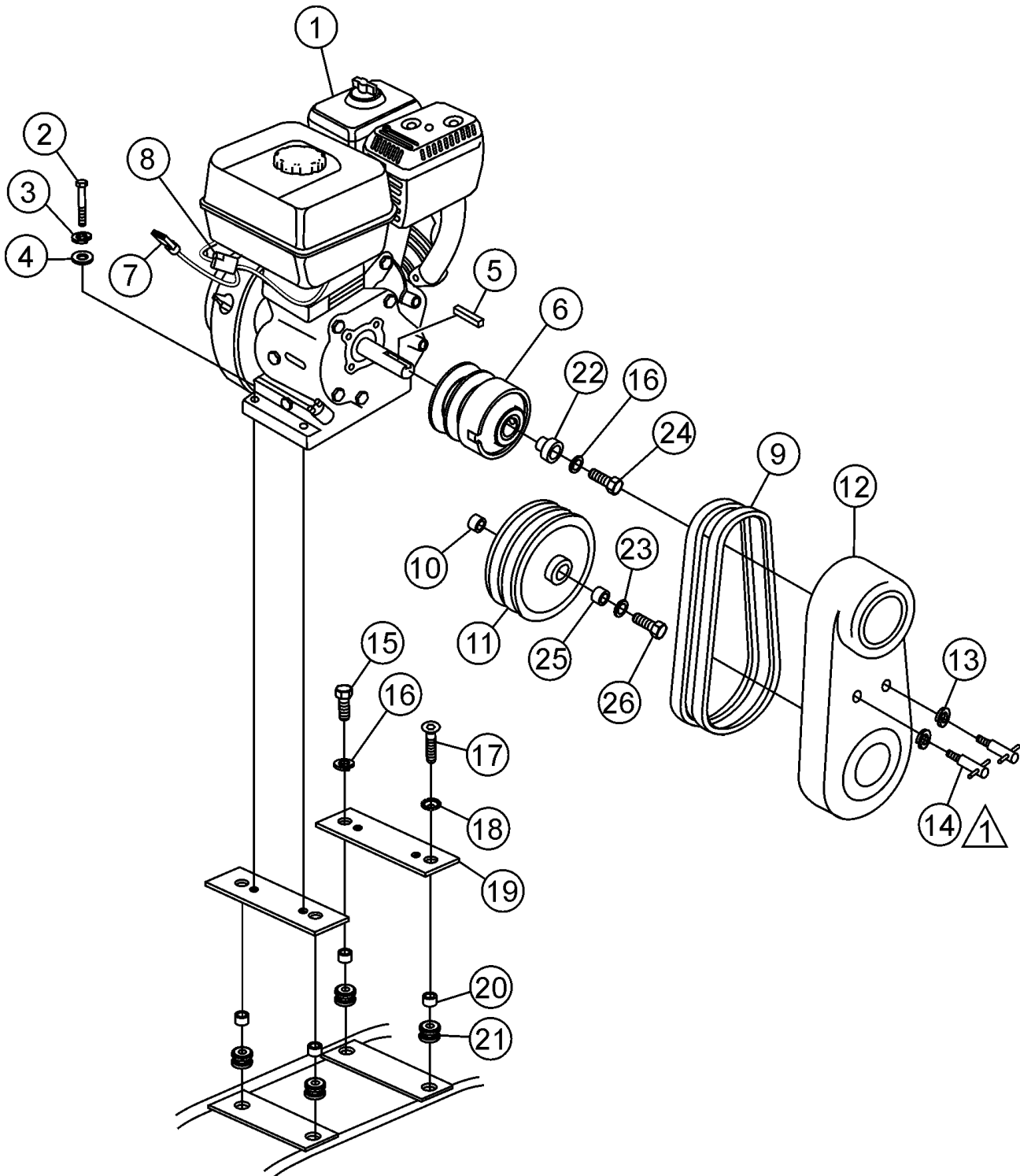

②⑦ LIFT STRAP-
CONTACT UNIT SALES DEPT./ACC. ITEM

△① ATTACHES TO LIFT BAIL BRACKET

ENGINE AND CLUTCH ASSY. (11 HP)

<u>NO.</u>	<u>PART NO.</u>	<u>PART NAME</u>	<u>QTY.</u>	<u>REMARKS</u>
1	1388	ENGINE, HONDA GX340 (11HP)	1	
2	1391	HHCS 5/16"-24 X 1-1/2"	4	
3	0161 C	LOCK WASHER 5/16"	4	
4	0300 B	FLAT WASHER 5/16"	4	
5	0310	SQUARE KEY 1/4" X 1/4" X 1-1/2"	1	
6	2480	CLUTCH, 4" P-G 35 DEGREE 1"	1	
7	1488	WIRE, SAFETY SWITCH	1	
8	1475	CONNECTOR, SPLICE TAP	1	
9	0261	BELT, A31 GATES HP11	2	
10	2362	SPACER, 1-1/4" X .878 X .375I	1	
11	9119	PULLEY, HD48 2AK54 X 7/8", 5.25 OD	1	
12	10222	GUARD, BELT	1	
13	10136	LOCK WASHER 1/4"	2	
14	2724	T-BOLT	2	
15	9154	SCREW, HHC 3/8"-16 X 1-3/4"	2	
16	0166 A	WASHER, LOCK 3/8" MED	3	
17	20982	SCREW, FSCS 3/8"-16 X 1-1/2" PLTD	2	
18	1480	WASHER, CS EXT. SHKP 3/8	2	
19	1951	PLATE, FRONT, 11HP HONDA	2	
20	1245	BUSHING, GUARD RING	4	
21	1247	GROMMET, 1/4" X 7/8"ID X 1-5/8"OD	4	
22	9123	RETAINER, CLUTCH	1	
23	9120	RETAINER, DRIVEN PULLEY	1	
24	0478	SCREW, HHC 3/8"-24 X 2-1/4"	1	
25	2361	SPACER, 1-1/4" X .878 X .437L	1	
26	1313	SCREW, FHSC 3/8"-24 X 3/4" PLAIN	1	
27		LIFT STRAP.....	1.....	CONTACT UNIT SALES DEPARTMENT

ENGINE AND CLUTCH ASSY. (13 HP)

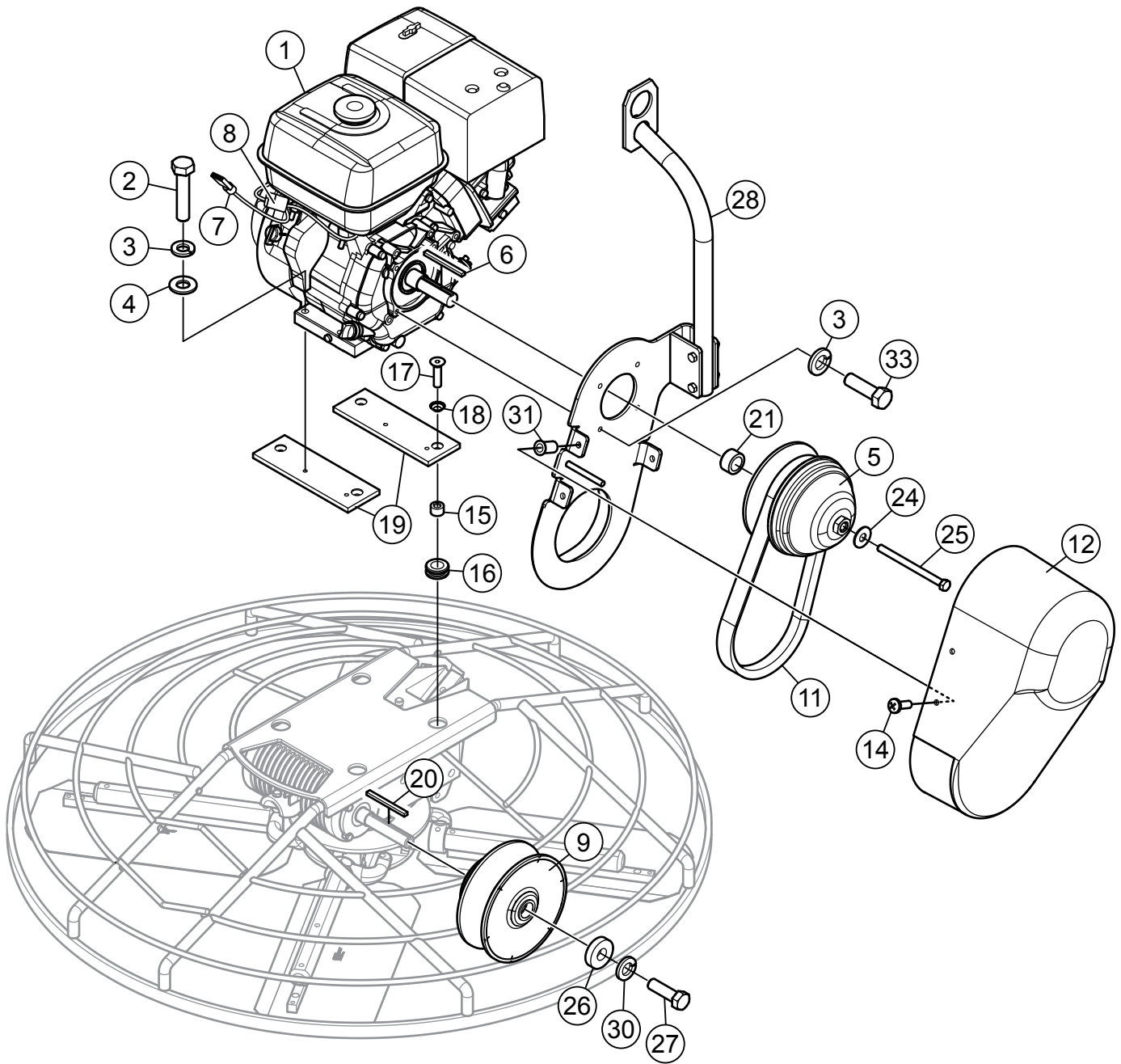

ENGINE AND CLUTCH ASSY. (13 HP)

<u>NO.</u>	<u>PART NO.</u>	<u>PART NAME</u>	<u>QTY.</u>	<u>REMARKS</u>
1	22624	ENGINE, HONDA GX390 (13HP)	1	
2	1391	HHCS 5/16"-24 X 1-1/2"	4	
3	0161 C	WASHER, LOCK, 5/16"	8	
4	0300 B	FLAT WASHER 5/16"	4	
5	22613	CLUTCH, CVT DRIVE HD	1	
6	22632	KEY, STEEL .188 X .250 X 1.813	1	
7	1488	WIRE, SAFETY SWITCH	1	
8	1475	CONNECTOR, SPLICE TAP	1	
9	22614	CLUTCH, CVT DRIVEN HD	1	
11	22617	BELT, CVT HD WALK BEHIND	1	
12	22615	GUARD, BELT CV TECH CLUTCH	1	
14	30119	SCREW, 1/4"-20 X 7/8" IND HEX, DOG PT	3	
15	1245	BUSHING, GUARD RING	4	
16	1247	GROMMET, 1/4" X 7/8" ID X 1-5/8"OD	4	
17	20982	SCREW, FSCS 3/8"-16 X 1-1/2" PLTD	4	
18	1480	WASHER, CS EXT. SHKP 3/8"	4	
19	11541	PLATE, ENGINE MOUNT 13HP HONDA	2	
20	1580	SQUARE KEY	1	
21	22633	SPACER, CV TECH CLUTCH	1	
24	933242	WASHER, FLAT SAE 3/8" GRD 9 YZ	1	
25	22626	SCREW, HHC 3/8"-24 X 5"	1	
26	22631	WASHER, CLUTCH RETAINER	1	
27	22627	SCREW, HHC 3/8"-24 X 1-1/4"	1	
28	22628	LIFT BALE WELDMENT, CV TECH	1	
30	0166 A	WASHER, LOCK, 3/8" MED.	1	
31	29452	NUT, BLIND 1/4"-20 X .165-.260	3	
33	10229	SCREW, HHC 5/16"-24 X 1"	4	

GUARD RING ASSY. (OLD STYLE)

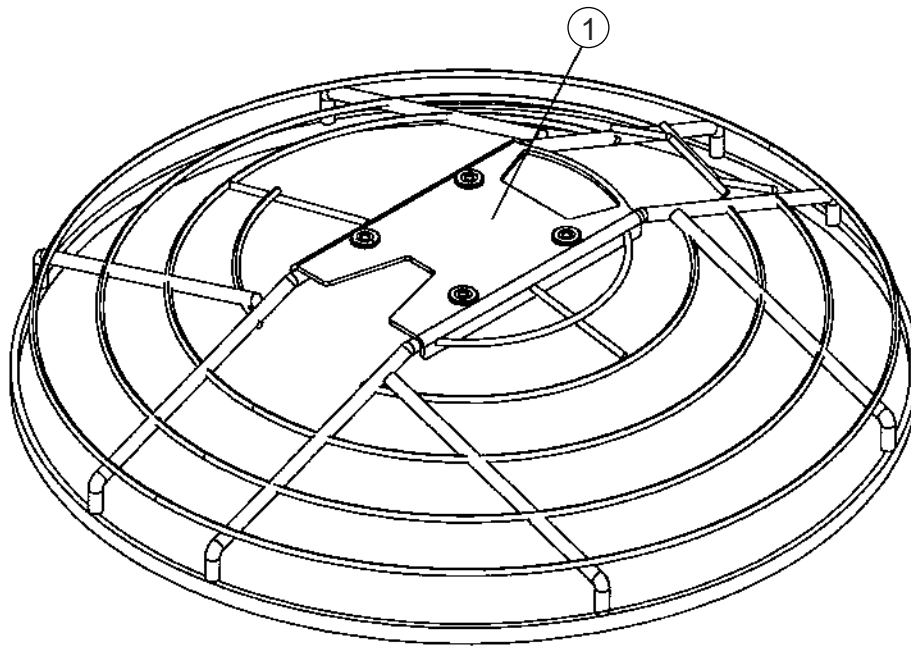

GUARD RING ASSY. (OLD STYLE)

<u>NO.</u>	<u>PART NO.</u>	<u>PART NAME</u>	<u>QTY.</u>	<u>REMARKS</u>
1	9178	GUARD RING ASSEMBLY	1	

GUARD RING ASSY. (NEW STYLE)

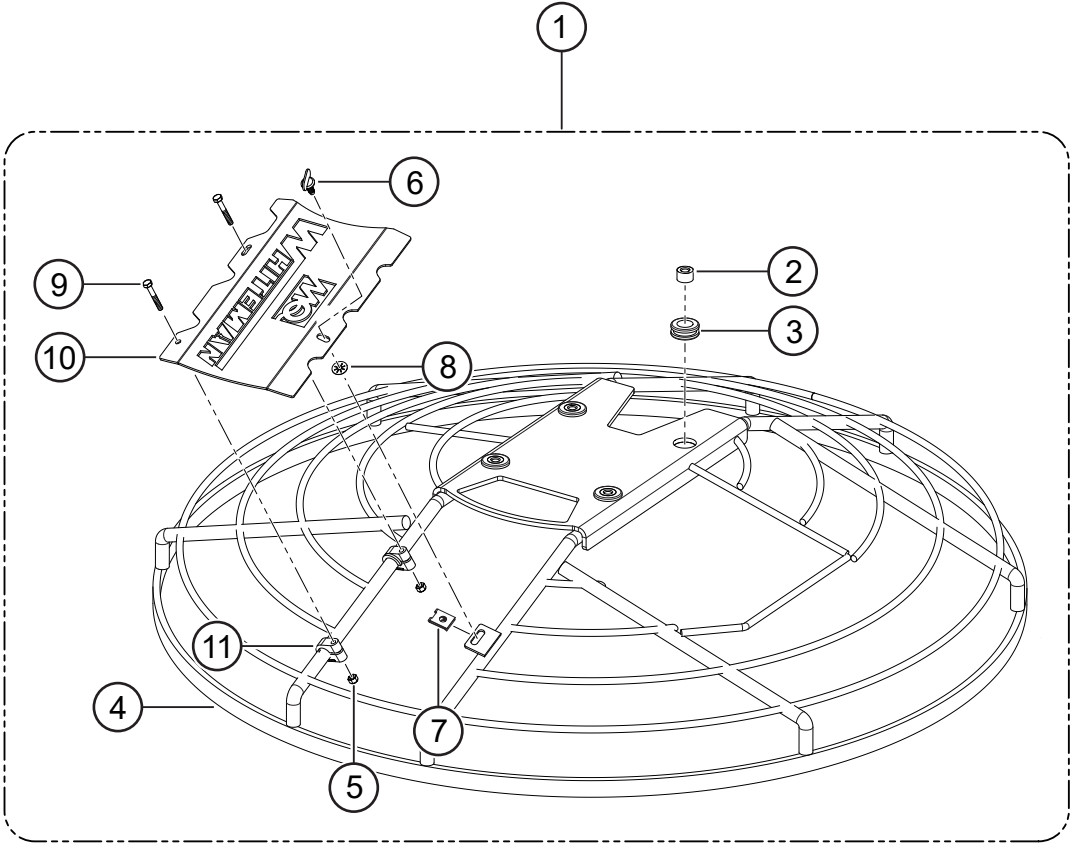

GUARD RING ASSY. (NEW STYLE)

<u>NO.</u>	<u>PART NO.</u>	<u>PART NAME</u>	<u>QTY.</u>	<u>REMARKS</u>
1	7299	GUARD RING ASSEMBLY	1.....	INCLUDES ITEMS W/#
2#	1245	BUSHING, GURAD RING	4	
3#	1247	GROMMET, 1/4 X .875 ID. X 1-5/8 OD	4	
4#	9178	GUARD RING W/A	1	
5#	10024	NUT, NYLOC 1/4-20	2	
6#	21893	SCREW, FAST LEAD	1	
7#	21894	NUT, CLIP, FAST LEAD	1	
8#	21986	WASHER, FAST LEAD-STAINLES	1	
9#	26250	SCREW, HHC 1/4-20 X1-3/4	2	
10#	43991	ACCESS DOOR	1	
11#	43993	PIPE CLAMP, 3/4	2	

STABILIZER RING ASSY.

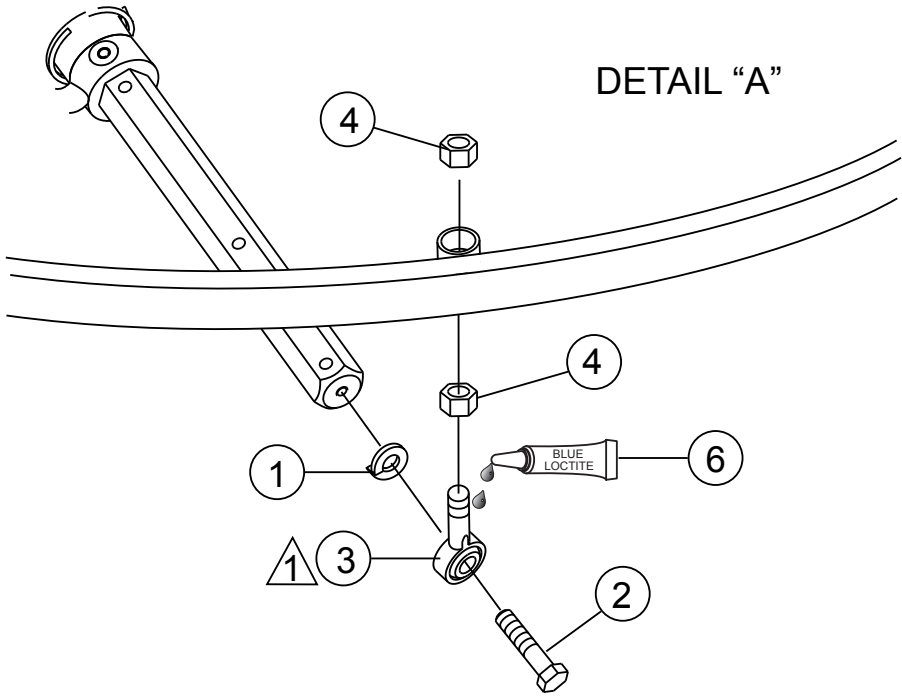
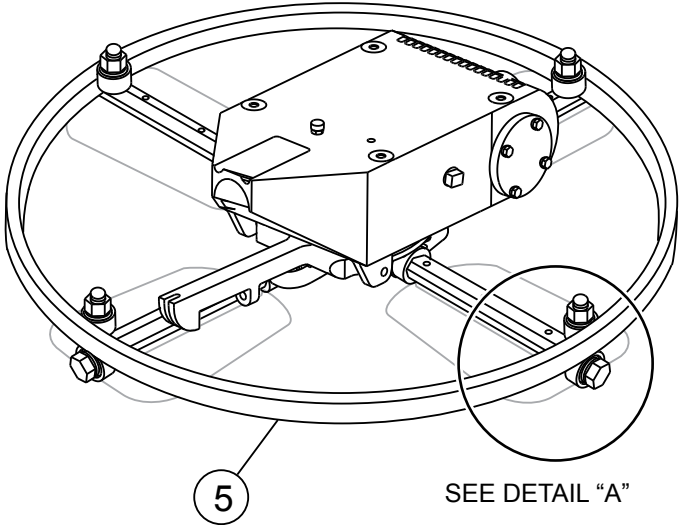

△ APPLY LOCTITE 242 BLUE OR EQUIVALENT.

STABILIZER RING ASSY.

<u>NO.</u>	<u>PART NO.</u>	<u>PART NAME</u>	<u>QTY.</u>	<u>REMARKS</u>
1	0300 B	WASHER, FLAT SAE 5/16"	4	
2	1237	SCREW, SCH 5/16"-18 X 7/8" NYL NP	4	
3	1723	ROD END, 5/16"-24 MALE	4	
4	6014 C	NUT, HEX FINISH 5/16"-24	8	
5	9148	RING, STABILIZER EXT ARM HD	1	
6	1477	LOCTITE, #242 BLUE .5CC BOTTLE	AR	

BLADES AND PAN ASSY.

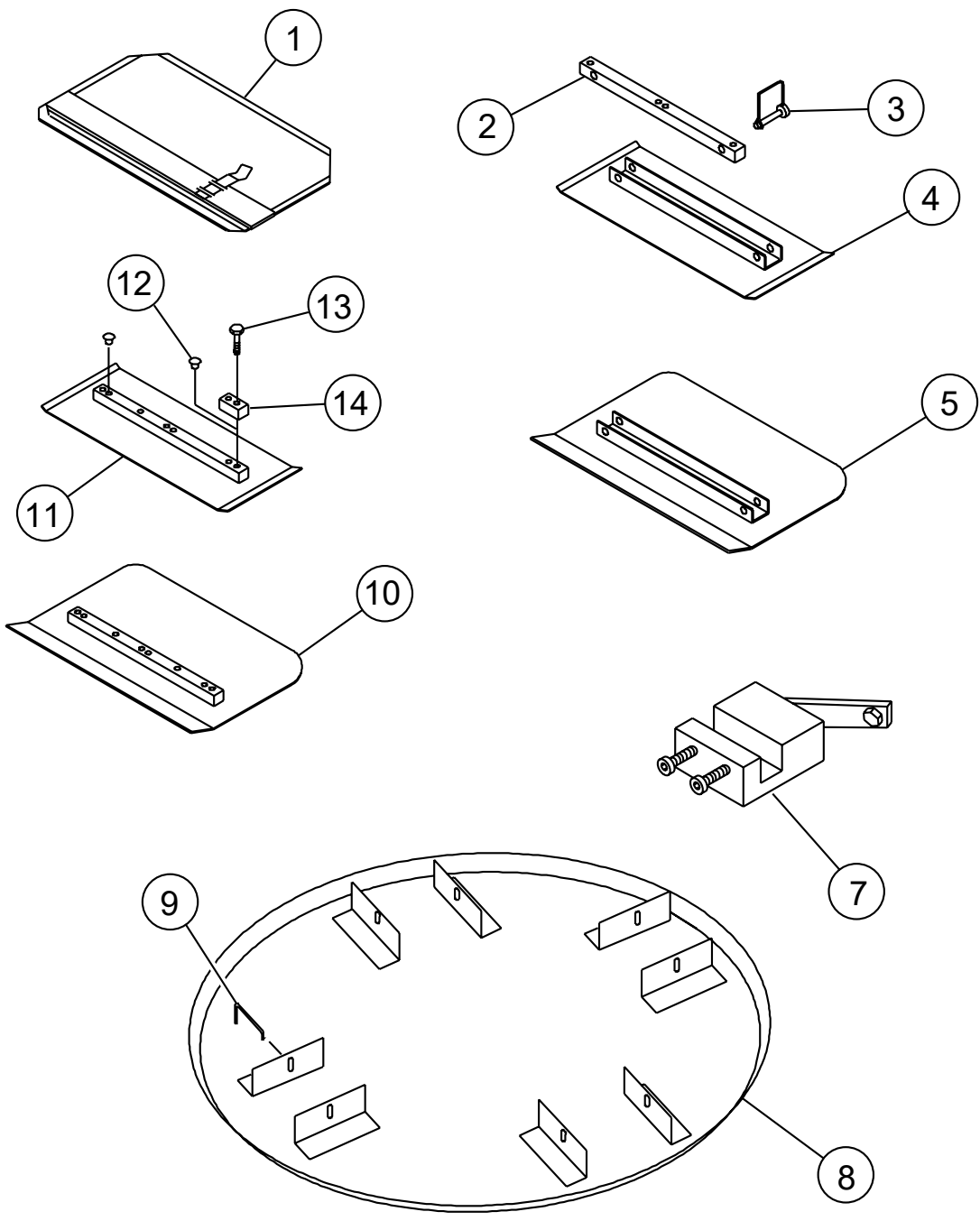

BLADES AND PAN ASSY.

<u>NO.</u>	<u>PART NO.</u>	<u>PART NAME</u>	<u>QTY.</u>	<u>REMARKS</u>
1	CL444F	FLOAT BLADE 10" X 18", 46"/48".....	4.....	CONTACT UNIT SALES DEPT.
2	QB1857	UNIVERSAL MOUNTING BAR.....	4.....	CONTACT UNIT SALES DEPT.
3	QS1869	SNAP PIN 1/4" X 1-3/4"	8.....	CONTACT UNIT SALES DEPT.
4	QF1874	UNIVERSAL FINSH BLADE	4.....	CONTACT UNIT SALES DEPT.
5	QF1874	UNIVERSAL COMBO BLADE.....	4.....	CONTACT UNIT SALES DEPT.
7	9177	TROWEL ARM ADJ. FIXTURE ASSY.....	1.....	CONTACT UNIT SALES DEPT.
8	11017W	FLOAT PAN, 46" 4-BLADE SF	1.....	CONTACT UNIT SALES DEPT.
9	20646	FLOAT DISC LATCH PIN.....	4.....	CONTACT UNIT SALES DEPT.
10	C464	COMBO BLADE 8" X 18" X 46" AND 48"	4.....	CONTACT UNIT SALES DEPT.
11	F400	FINISH BLADE.....	4.....	CONTACT UNIT SALES DEPT.
12	1434	TROWEL LUG (FINISH BLADE ONLY).....	4.....	CONTACT UNIT SALES DEPT.
13	0202	SCREW, HHC 5/16"-18 X 1" ZINC	4	
14	0201	LUG, GUARD RING	4	

LIFTING BAIL ASSY. (OPTION)

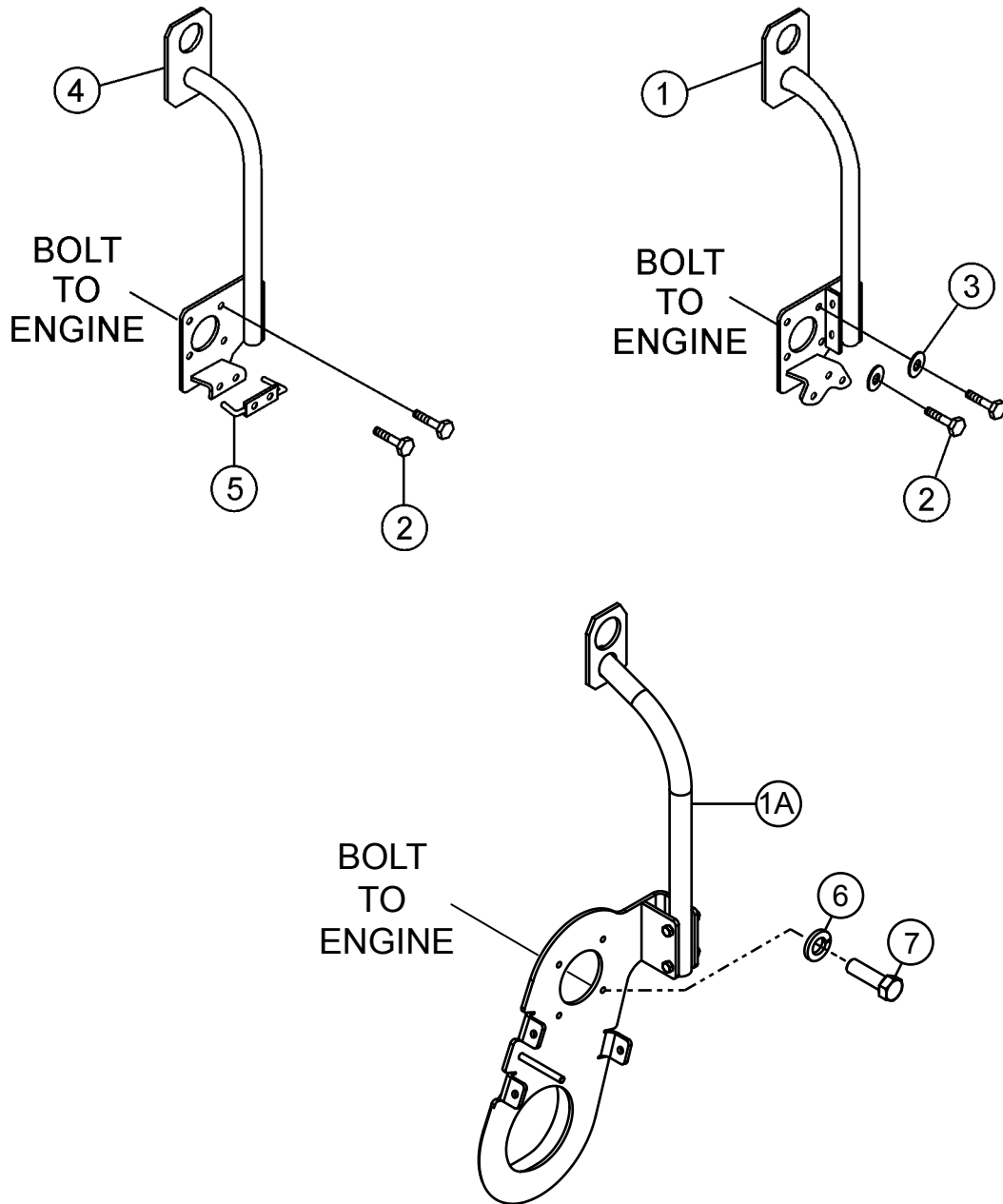

LIFTING BAIL ASSY. (OPTION)

<u>NO.</u>	<u>PART NO.</u>	<u>PART NAME</u>	<u>QTY.</u>	<u>REMARKS</u>
1	11554	LIFT BALE ASSY.....	1CONTACT UNIT SALES DEPT./ACC. ITEM
1A	22628	LIFT BALE WELDMENT, CV TECH.....	1CONTACT UNIT SALES DEPT./ACC. ITEM
2	10229	HHCS 5/16-24 X 1"	4	
3	0161 A	LOCK WASHER 5/16"	4	
4	10157	LIFTING BAIL ASSY.....	1CONTACT UNIT SALES DEPT. /ACC. ITEM
5	2360	RUNNER, BELT HONDA	1	
6	0161 C	WASHER, LOCK	4	
7	10229	SCREW, HHC 5/16-24 X 1"	4	

ENGINE SERVICE PARTS

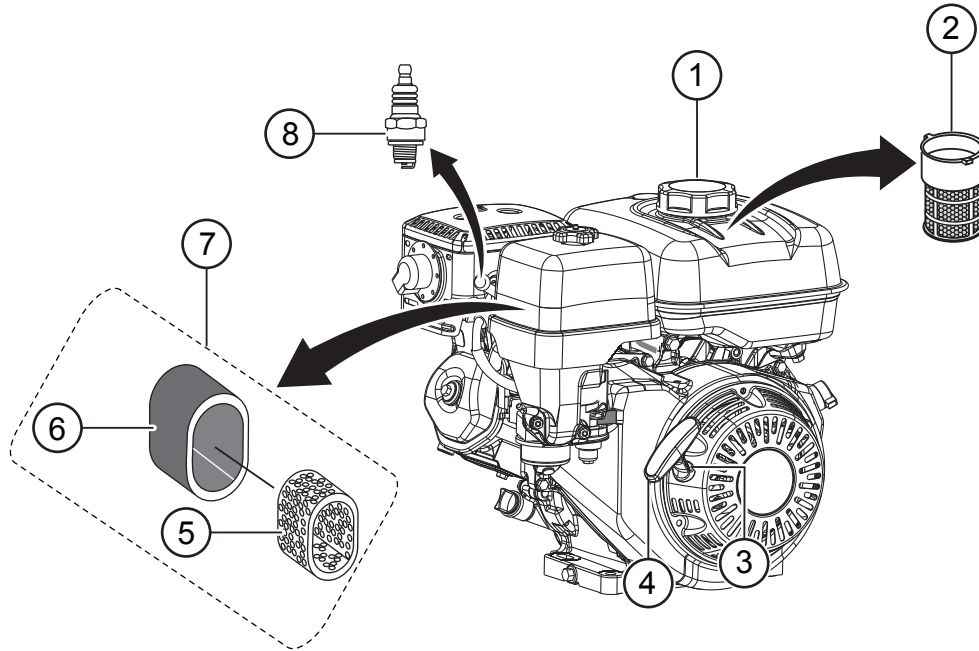

ENGINE SERVICE PARTS

<u>NO.</u>	<u>PART NO.</u>	<u>PART NAME</u>	<u>QTY.</u>	<u>REMARKS</u>
1	17620Z4H900	CAP, FUEL	1	
2	17672ZE2W01	FILTER, FUEL	1	
3◇	28462ZE3W01	ROPE, RECOIL STARTER	1	
3◆	28462ZV7003	ROPE, RECOIL STARTER	1	
4	28461ZE2W02	GRIP, RECOIL STARTER	1	
5		FILTER, INNER AIR.....	1	NOT SOLD SEPARATELY
6	17218ZE3505	FILTER, OUTER AIR	1	
7	17210ZE3505	ELEMENT, AIR CLEANER	1	
8◇	9807956846	SPARK PLUG	1	
8◆	9807955846	SPARK PLUG	1	

NOTICE

- ◇ HONDA GX340K1QA2
- ◆ HONDA GX390K1QA2

PARTS MANUAL

HERE'S HOW TO GET HELP

PLEASE HAVE THE MODEL AND SERIAL
NUMBER ON-HAND WHEN CALLING

UNITED STATES

Multiquip Inc.

(310) 537- 3700
6141 Katella Avenue Suite 200
Cypress, CA 90630
E-MAIL: mq@multiquip.com
WEBSITE: www.multiquip.com

CANADA

Multiquip

(450) 625-2244
4110 Industriel Boul.
Laval, Quebec, Canada H7L 6V3
E-MAIL: infocanada@multiquip.com

UNITED KINGDOM

Multiquip (UK) Limited Head Office

0161 339 2223
Unit 2, Northpoint Industrial Estate, Globe Lane,
Dukinfield, Cheshire SK16 4UJ
E-MAIL: sales@multiquip.co.uk

© COPYRIGHT 2023, MULTIQUIP INC.

Multiquip Inc, the MQ logo are registered trademarks of Multiquip Inc. and may not be used, reproduced, or altered without written permission. All other trademarks are the property of their respective owners and used with permission.

This manual MUST accompany the equipment at all times. This manual is considered a permanent part of the equipment and should remain with the unit if resold.

The information and specifications included in this publication were in effect at the time of approval for printing. Illustrations, descriptions, references and technical data contained in this manual are for guidance only and may not be considered as binding. Multiquip Inc. reserves the right to discontinue or change specifications, design or the information published in this publication at any time without notice and without incurring any obligations.



PN: 13410



Flextool

1956 Dandenong Road, Clayton VIC 3168, Australia

Phone (AUS): 1300 353 986

flextool.com.au

ABN 80 069 961 968

This manual summarises our best knowledge of the product based on the information available at the time of publication. You should read this manual carefully and consider the information in the context of how the product will be used. Our responsibility for products sold is subject to our standard terms and conditions of sale.

DISCLAIMER:

Any advice, recommendation, information, assistance or service provided by us in this manual is given in good faith and is believed by us to be appropriate and reliable. However, any advice, recommendation, information, assistance or service provided by us is provided without liability or responsibility PROVIDED THAT the foregoing shall not exclude, limit, restrict or modify the right entitlements and remedies conferred upon any person or the liabilities imposed upon us by any condition or warranty implied by Commonwealth, State or Territory Act or ordinance void or prohibiting such exclusion limitation or modification. The product can be expected to perform as indicated in this manual so long as operation and operational procedures of the individual products are followed as recommended in this manual.

Design and technical specifications may be subject to changes.

© This publication is copyright. All rights are reserved. Flextool is a registered trade mark of Parchem Construction Supplies Pty Ltd. Multiquip, MQ and Whiteman are registered trade marks of Multiquip Inc.