

SPARE PARTS MANUAL

FLEXTOOL DRIVE UNIT FDU-DE2 (DIESEL ELECTRIC START)



Version 5.0 (September 2024)

HOW TO READ THIS SPARE PARTS MANUAL

The following section explains the different symbols and remarks used in this manual and how to interpret the information outlined in the following pages.

Section 1 – Diagram and parts list

- Item No : Used to reference the spare part in the diagram to the parts list.
- Product Code : Used to indicate the unique Flextool spare parts product code used when ordering parts.

Product code can be presented in the following ways:

- Number : Signifies the unique Flextool spare parts product code used when placing orders.
 - Blank : Used for parts pending formal part number assignment at the time of publication. Also denotes that the spare parts are not sold separately or are unavailable from Flextool.
 - See remarks : Indicates that the spare parts are part of an assembly, service kit or is part of a serial number range where a particular part is used. Please refer to remarks to find further information.
- Description : Used to provide a concise description of the spare part such as size, length, diameter, models, etc.
 - Qty : Indicates the quantity of part(s) required for the equipment. Please verify the required quantity when placing an order.
 - Remarks : Refers to additional information, including assembly kit, service kit and serial number range where particular part is used
 - AS : Refers to the parts supplied with an assembly kit.
 - SK : Refers to the parts supplied with a service kit.
 - Serial number: Indicates the range of serial number where particular part is used.

Section 2 – Fast moving spare parts

FLEXTOOL DRIVE UNIT FDU-DE2

Description	Product Code
BELL HOUSING ASSEMBLY	NPS03374-UNIT
DRIVE DOG SERVICE KIT	NPS07161-UNIT
TRIGGER SERVICE KIT	NPS07159-UNIT
RUBBER MOUNT SERVICE KIT 4 PACK	NPS01579-UNIT

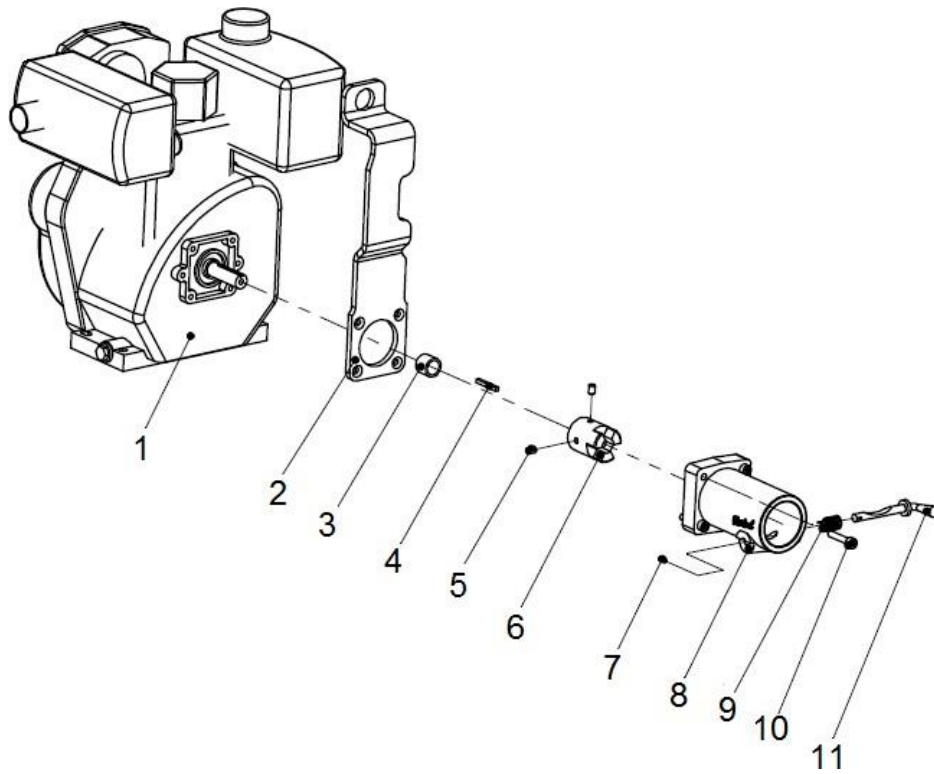

Engine and Coupling

Item No.	Product Code	Description	Qty	Remarks
1	NPS01934-UNIT	YAN ENGINE YANMAR L48N5 (ELEC START)	1	
2	NPS02891-UNIT	FLX LIFTING HOOK (CNVR3-010)	1	
3	See Remarks	FLX SPACER (CNVR1-006)	1	Use SK-1
4	NPS00779-UNIT	FLX KEY (CNVR1-007)	1	
5	See Remarks	FLX GRUB SCREW (CNVR1-008)	2	Use SK-1
6	See Remarks	FLX DRIVE DOG (CNVR1-009)	1	Use SK-1
7	See Remarks	FLX ROLL PIN (CNVR1-011)	1	Use AS-1 or SK-2
8	See Remarks	FLX BELL HOUSING (CNVR1-012)	1	Use AS-1
9	See Remarks	FLX TRIGGER SPRING (CNVR1-013)	1	Use AS-1 or SK-2
10	NPS01581-UNIT	FLX SOCKET HEAD CAP SCREW (CNVR3-015)	4	
11	See Remarks	FLX TRIGGER (CNVR1-014)	1	Use AS-1 or SK-2

Engine and Coupling - Assembly / Service Kits

Item No.	Product Code	Description	Qty	Remarks
AS-1	NPS03374-UNIT	FLX ASSY BELL HOUSING (CNVR3-017)	1	Inc Items: 7, 8, 9, 11
SK-1	NPS07161-UNIT	FLX SERVICE KIT DRIVE DOG GX160-QX (CNVR3-016)	1	Inc Items: 3, 5, 6
SK-2	NPS07159-UNIT	FLX SERVICE KIT TRIGGER (CNVR3-019)	1	Inc Items: 7, 9, 11

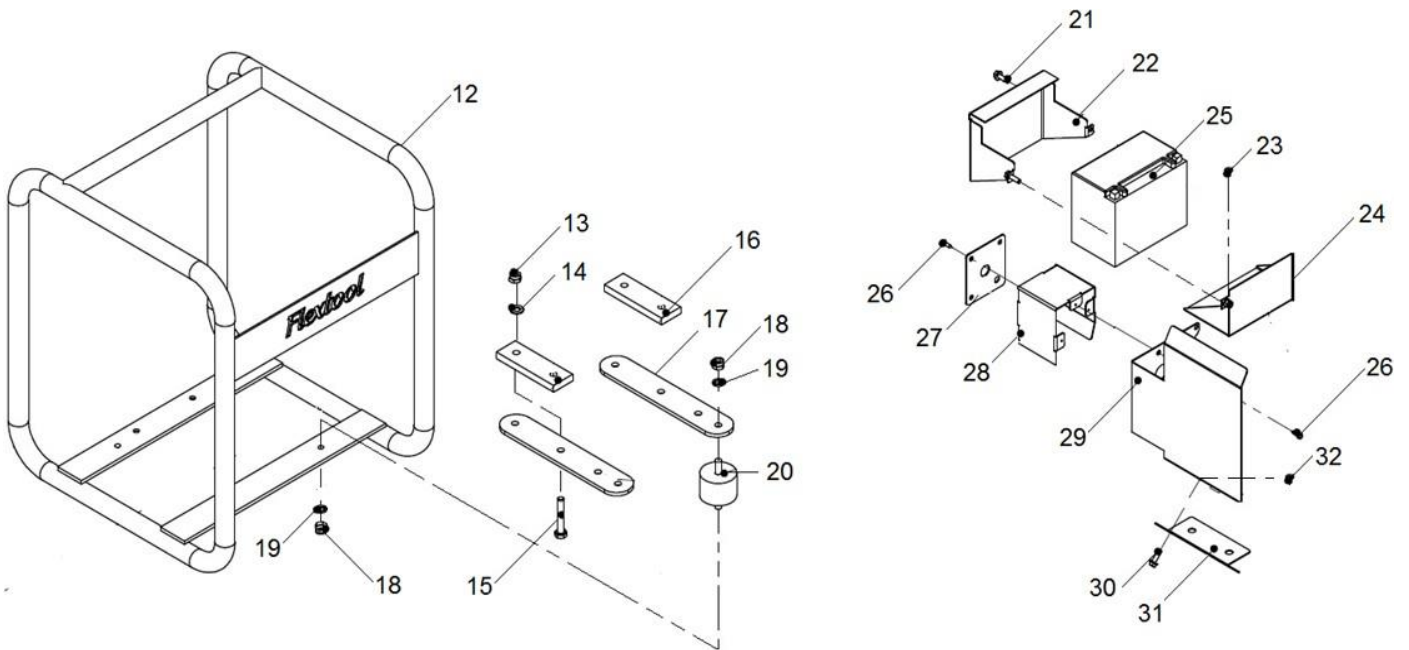

Frame and Engine Mount

Item No.	Product Code	Description	Qty	Remarks
12	NPS03047-UNIT	FLX DRIVE UNIT FRAME FDU-D2 / DE2 (CNVR6A-007)	1	
13	See Remarks	FLX NYLOCK NUT (CNVR6A-001)	4	Use SK-3
14	See Remarks	FLX FLAT WASHER (CNVR6A-002)	4	Use SK-3
15	See Remarks	FLX BOLT (CNVR6A-004)	4	Use SK-3
16	NPS03049-UNIT	FLX ENGINE MOUNT SPACER FDU-DE2 (CNVR6B-009)	2	
17	NPS00127-UNIT	FLX ENGINE MOUNT STRAP FDU-DE2 (CNVR6A-003)	2	
18	See Remarks	FLX NYLOCK NUT (CNVR4A-001)	8	Use SK-4
19	See Remarks	FLX FLAT WASHER (CNVR4A-002)	8	Use SK-4
20	See Remarks	FLX RUBBER MOUNT (CNVR4A-005)	4	Use SK-4
21	See Remarks	FLX BOLT M6X20 (CNVR6B-014)	4	Use SK-5
22	See Remarks	FLX BATTERY CASE UPPER SECTION (CNVR6B-013)	1	Use SK-5
23	See Remarks	FLX BOLT M6X10 (CNVR6B-015)	2	Use SK-5
24	See Remarks	FLX BATTERY CASE LOWER SECTION (CNVR6B-012)	1	Use SK-5
25	See Remarks	FLX BATTERY 12V (CNVR6B-018)	1	Non-Stock Part (Source Locally)
26	See Remarks	FLX SCREW (CNVR6B-021)	6	Use SK-6
27	See Remarks	FLX IGN SWITCH COVER PANEL (CNVR6B-020)	1	Use SK-6
28	See Remarks	FLX IGN SWITCH COVER SHROUD (CNVR6B-019)	1	Use SK-6
29	See Remarks	FLX STARTER MOTOR COVER (CNVR6B-022)	1	Use SK-6
30	See Remarks	FLX BOLT M6X20 (CNVR6B-014)	2	Use SK-6
31	See Remarks	FLX STARTER MOTOR MOUNT PLATE (CNVR6B-017)	1	Use SK-6
32	See Remarks	FLX NUT M6	2	Use SK-6

Frame and Engine Mount - Assembly / Service Kits

Item No.	Product Code	Description	Qty	Remarks
SK-3	NPS03048-UNIT	FLX SERVICE KIT BOLT SET FDU (CNVR6A-008)	1	Inc Items: 13 - 15
SK-4	NPS01579-UNIT	FLX SERVICE KIT RUBBER MOUNT FDU (CNVR2-020)	1	Inc Items: 18 - 20
SK-5	NPS03050-UNIT	FLX BATTERY CASE KIT (CNVR6B-028)	1	Inc Items: 20 - 24
SK-6	NPS03051-UNIT	FLX IGN & STARTER PANEL KIT FDU-DE2 (CNVR6B-029)	1	Inc Items: 26 - 32



Flextool

1956 Dandenong Road, Clayton VIC 3168, Australia

Phone (AUS): 1300 353 986

flextool.com.au

ABN 80 069 961 968

This manual summarises our best knowledge of the product based on the information available at the time of publication. You should read this manual carefully and consider the information in the context of how the product will be used. Our responsibility for products sold is subject to our standard terms and conditions of sale.

DISCLAIMER:

Any advice, recommendation, information, assistance or service provided by us in this manual is given in good faith and is believed by us to be appropriate and reliable. However, any advice, recommendation, information, assistance or service provided by us is provided without liability or responsibility PROVIDED THAT the foregoing shall not exclude, limit, restrict or modify the right entitlements and remedies conferred upon any person or the liabilities imposed upon us by any condition or warranty implied by Commonwealth, State or Territory Act or ordinance void or prohibiting such exclusion limitation or modification. The product can be expected to perform as indicated in this manual so long as operation and operational procedures of the individual products are followed as recommended in this manual.

Design and technical specifications may be subject to changes.

© This publication is copyright. All rights are reserved. Flextool is a registered trade mark of Parchem Construction Supplies Pty Ltd.