



SPARE PARTS MANUAL

FLEXTOOL PROFINISH[®] WALK-BEHIND POWER TROWEL FP424-2



Version 1.0 (March 2025)

FOR MORE INFORMATION VISIT flextool.com.au

HOW TO READ THIS SPARE PARTS MANUAL

The following section explains the different symbols and remarks used in this manual and how to interpret the information outlined in the following pages.

Section 1 – Diagram and parts list

- Item No : Used to reference the spare part in the diagram to the parts list.
- Product Code : Used to indicate the unique Flextool spare parts product code used when ordering parts.

Product code can be presented in the following ways:

- Number : Signifies the unique Flextool spare parts product code used when placing orders.
 - Blank : Used for parts pending formal part number assignment at the time of publication. Also denotes that the spare parts are not sold separately or are unavailable from Flextool.
 - See remarks : Indicates that the spare parts are part of an assembly, service kit or is part of a serial number range where a particular part is used. Please refer to remarks to find further information.
- Description : Used to provide a concise description of the spare part such as size, length, diameter, models, etc.
 - Qty : Indicates the quantity of part(s) required for the equipment. Please verify the required quantity when placing an order.
 - Remarks : Refers to additional information, including assembly kit, service kit and serial number range where particular part is used
 - AS : Refers to the parts supplied with an assembly kit.
 - SK : Refers to the parts supplied with a service kit.
 - Serial number: Indicates the range of serial number where particular part is used.

Section 2 – Fast moving spare parts

FLEXTOOL PROFINISH WALK-BEHIND POWER TROWEL FP424-2

Description	Product Code
FLX THROTTLE LEVER & CABLE	NPS02850-UNIT
FLX TILT CABLE	NPS02153-UNIT
FLX V-BELT A27	NPS00481-UNIT
FLX HEX HEAD SCREW ¼" X 1½" UNC	NPS02848-UNIT
FLX CENTRIFUGAL SAFETY SWITCH ASSY	NPS07245-UNIT

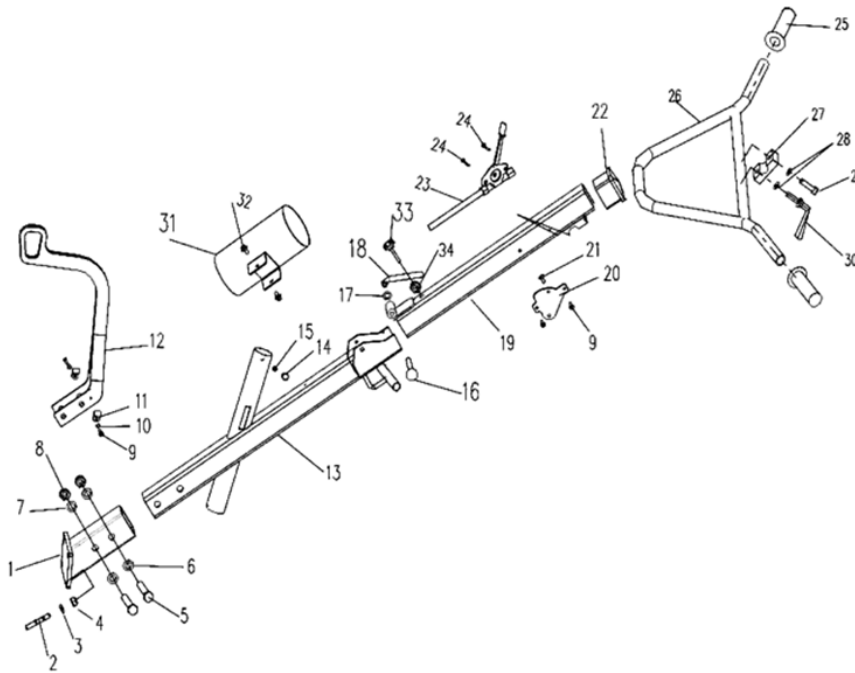

Handle

Item No.	Product Code	Description	Qty	Remarks
1	NPS03101-UNIT	FLX CONNECTING PLATE (SY-L1090)	1	
2	NPS02141-UNIT	FLX SCREW (SY-GB211040)	4	
3	NPS07212-UNIT	FLX WASHER M10 (SY-GB1210)	4	
4	NPS07248-UNIT	FLX LOCK NUT M10 (SY-GB1010)	4	
5	NPS02142-UNIT	FLX HEX HEAD SCREW M12X85 (SY-GB011285)	2	
6	NPS01923-UNIT	FLX WASHER M12 (SY-GB1312)	2	
7	NPS07255-UNIT	FLX SPRING WASHER M12 (SY-GB1212)	2	
8	NPS07253-UNIT	FLX NY-LOCK NUT M12 (SY-GB1010)	2	
9	NPS02182-UNIT	FLX SCREW M5X10 (SY-GB150510)	4	
10	NPS02316-UNIT	FLX WASHER M5 (SY-GB1205)	2	
11	NPS03102-UNIT	FLX CLAMP (SY-WY361)	2	
12	NPS02740-UNIT	FLX LIFTING HOOK (SY-L1091)	1	
13	NPS02743-UNIT	FLX HANDLE (SY-L1092)	1	
14	NPS02187-UNIT	FLX HEX SCREW M6X12 (SY-GB010612)	1	
15	NPS02188-UNIT	FLX WASHER M6 (SY-GB1206)	1	
16	NPS02741-UNIT	FLX SCREW M8X75 (SY-GB350875)	1	
17	NPS02194-UNIT	FLX WASHER M8 (SY-GB1208)	1	
18	NPS07224-UNIT	FLX NUT M8 (SY-L1105)	1	
19	NPS02865-UNIT	FLX UPPER HANDLE (SY-L1093)	1	
20	NPS03103-UNIT	FLX MOUNTING PLATE (SY-L1094)	1	
21	NPS07666-UNIT	FLX SOCKET HEAD SCREW M5X10 (SY-GB030510-G1)	2	
22	NPS02866-UNIT	FLX PLUG (SY-WB222)	1	
23	See Remarks	FLX THROTTLE CABLE(SY-WB221)	1	Use AS-1
24	See Remarks	FLX THROTTLE LEVER (SY-GB030612-Q1)	2	Use AS-1
25	NPS02218-UNIT	FLX HANDLE GRIP (SY-WY312)	2	
26	NPS02742-UNIT	FLX TROWEL HANDLEBAR (SY-L1088)	1	
27	NPS02180-UNIT	FLX CLAMP BLOCK (SY-L1089)	1	
28	NPS07212-UNIT	FLX WASHER M10 (SY-GB1210)	2	
29	NPS02181-UNIT	FLX SOCKET HEAD SCREW M10X40 (SY-GB021040)	1	
30	NPS02149-UNIT	FLX SCREW M10 (SY-L1106)	1	
31	NPS02867-UNIT	FLX HANDLE CLAMP (SY-L1107)	1	
32	NPS02146-UNIT	FLX FLANGE SCREW M6X8 (SY-GB200608)	2	
33	NPS03104-UNIT	FLX PLUM BLOSSOM SCREW M10X20 (SY-WY307)	1	
34	NPS07248-UNIT	FLX LOCK NUT M10 (SY-GB1010)	1	

Handle - Assembly / Service Kits

Item No.	Product Code	Description	Qty	Remarks
AS-1	NPS02850-UNIT	FLX THROTTLE LEVER & CABLE (SY-WB221)	1	Inc Items: 23-24

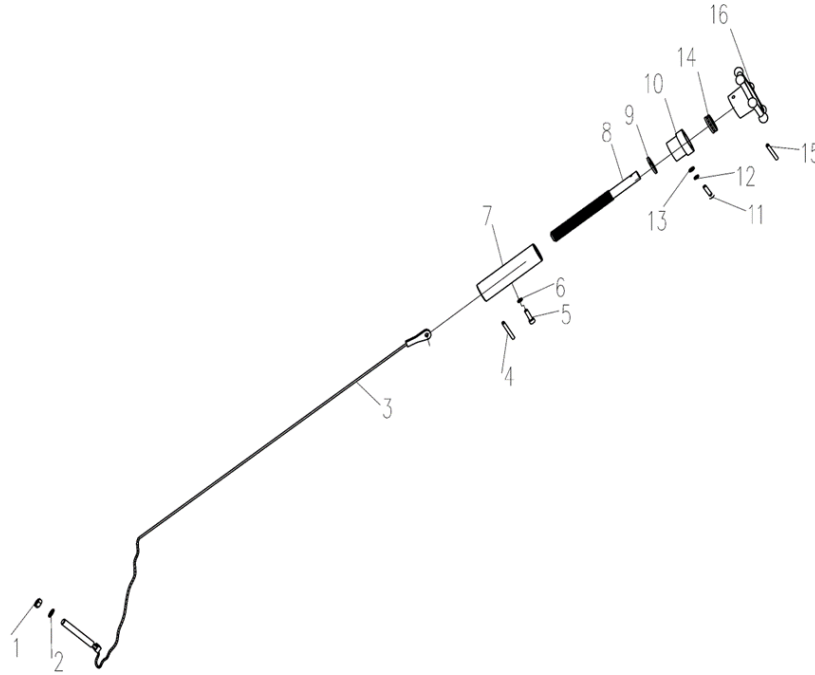

Control Mechanism

Item No.	Product Code	Description	Qty	Remarks
1	NPS07248-UNIT	FLX LOCK NUT M10 (SY-GB1010)	1	
2	NPS07212-UNIT	FLX WASHER M10 (SY-GB1210)	1	
3	NPS02153-UNIT	FLX TILT CABLE (SY-WB208)	1	
4	NPS02183-UNIT	FLX ROLLER PIN (SY-GB240530)	1	
5	NPS02184-UNIT	FLX SOCKET HEX SCREW M6X8 (SY-GB020608)	1	
6	NPS02185-UNIT	FLX SPRING WASHER M6 (SY-GB1306)	1	
7	NPS02154-UNIT	FLX ADJUSTING BUSHING (SY-L1001)	1	
8	NPS02155-UNIT	FLX SHAFT PITCH CONTROL (SY-L1002)	1	
9	NPS02186-UNIT	FLX WASHER M15 (SY-GB1215)	1	
10	NPS02156-UNIT	FLX BEARING HOLDER (SY-L1035)	1	
11	NPS02187-UNIT	FLX HEX SCREW M6X12 (SY-GB010612)	1	
12	NPS02185-UNIT	FLX SPRING WASHER M6 (SY-GB1306)	1	
13	NPS02188-UNIT	FLX WASHER M6 (SY-GB1206)	1	
14	NPS02157-UNIT	FLX BEARING 51103 (SY-ZC51103)	1	
15	NPS02158-UNIT	FLX PIN (SY-GB240540)	1	
16	NPS02854-UNIT	FLX PITCH CONTROL KNOB (SY-L1003)	1	

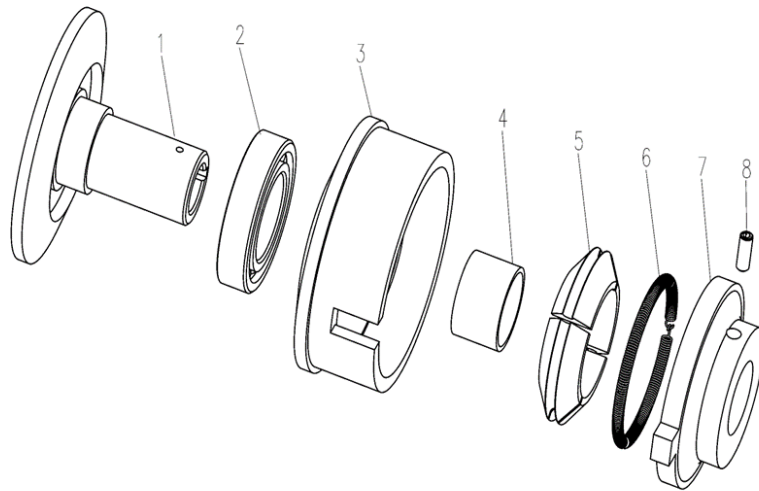

Clutch

Item No.	Product Code	Description	Qty	Remarks
1	See Remarks	FLX CLUTCH SPINDLE (SY-L1047)	1	Use AS-1
2	See Remarks	FLX BEARING 6006ZZ (SY-ZN6006ZZ)	1	Use AS-1
3	See Remarks	FLX CLUTCH DRUM (SY-L1048)	1	Use AS-1
4	See Remarks	FLX BEARING SLEEVE (SY-L1049)	1	Use AS-1
5	NPS02868-UNIT	FLX CLUTCH SHOES SET OF 4 (SY-L1050)	1	
6	NPS02754-UNIT	FLX CLUTCH SPRING (SY-WB224)	1	
7	See Remarks	FLX CLUTCH FACE PLATE (SY-L1051)	1	Use AS-1
8	NPS02755-UNIT	FLX GRUB SCREW M6X12 (SY-GB050612)	1	Use AS-1

Clutch - Assembly / Service Kits

Item No.	Product Code	Description	Qty	Remarks
AS-1	NPS02753-UNIT	FLX CLUTCH (SY-B218)	1	Inc Items: 1 – 8

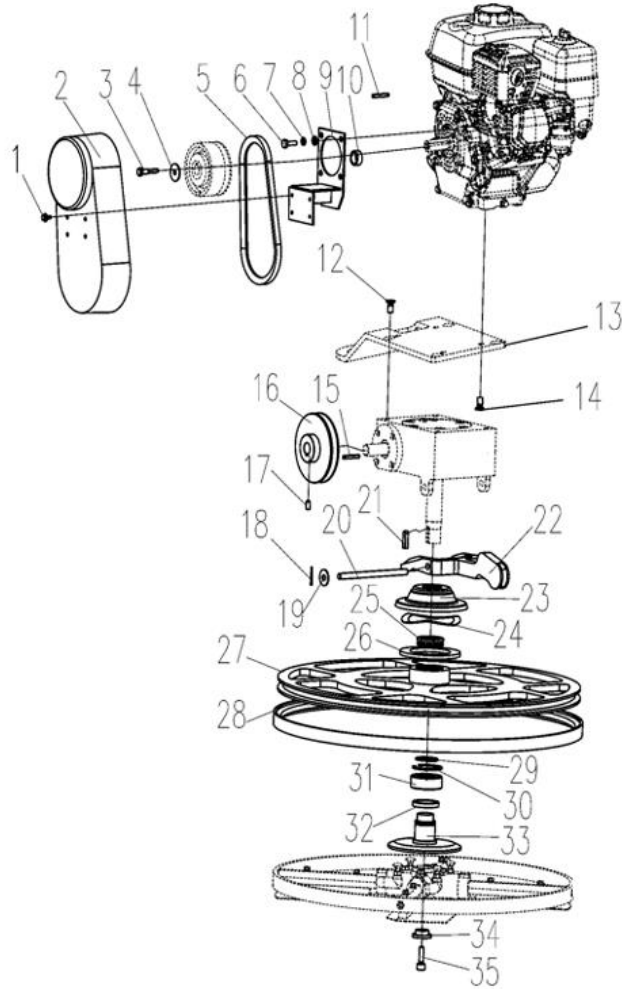

Drive System

Item No.	Product Code	Description	Qty	Remarks
1	NPS02371-UNIT	FLX FLANGE SCREW M6X12 (SY-GB200612)	4	Use AS-1
2	NPS02756-UNIT	FLX BELT GUARD (SY-WB118)	1	Use AS-1
3	NPS07233-UNIT	FLX BOLT M8X40 (SY-GB01082438-G2)	1	
4	NPS07234-UNIT	FLX RETAINER M8 (SY-GB12083003)	1	
5	NPS00481-UNIT	FLX V-BELT A27 (SY-WB025)	1	
6	NPS02193-UNIT	FLX HEX SCREW 5/16 X20 (SY-GB01082420-G2)	4	Use AS-1
7	NPS00404-UNIT	FLX SPRING WASHER M8 (SY-GB1308)	4	Use AS-1
8	NPS02194-UNIT	FLX WASHER M8 (SY-GB1208)	4	Use AS-1
9	See Remarks	FLX BELT GUARD INNER (SY-L1053)	1	Use AS-1
10	NPS02192-UNIT	FLX WASHER (SY-L1042)	1	
11	NPS02210-UNIT	FLX KEY 5X30 (SY-GB220530)	1	
12	NPS02670-UNIT	FLX SOCKET HEAD SCREW M10X20 (SY-GB031020)	4	
13		FLX ENGINE MOUNTING PLATE (SY-L1095)	1	
14	NPS07211-UNIT	FLX SOCKET HEAD SCREW M8X20 (SY-GB030820)	4	
15	NPS02210-UNIT	FLX KEY 5X30 (SY-GB220530)	1	
16	NPS02757-UNIT	FLX PULLEY (SY-L1055)	1	
17	NPS07239-UNIT	FLX SOCKET HEAD SCREW M8X16 (SY-GB060816)	1	
18	NPS02199-UNIT	FLX PIN (SY-GB282525)	2	
19	NPS02197-UNIT	FLX WASHER (SY-GB12102802)	2	
20	NPS03105-UNIT	FLX PIN (SY-L1056)	1	
21	NPS07203-UNIT	FLX KEY (SY-GB220830)	1	
22	NPS02758-UNIT	FLX BLADE TILT YOKE (SY-L1057)	1	
23	NPS02759-UNIT	FLX PRESSURE PLATE COVER (SY-L1058)	1	

Drive System

Item No.	Product Code	Description	Qty	Remarks
24	NPS02760-UNIT	FLX WASHER (SY-L1059)	1	
25	NPS02761-UNIT	FLX PRESSURE PLATE BEARING (SY-ZZ35TM)	1	
26	NPS02762-UNIT	FLX BLADE LIFTING RING (SY-L1060)	1	
27	NPS02763-UNIT	FLX GUARD RING (SY-L1061)	1	
28	NPS02764-UNIT	FLX RUBBER RING (SY-L1062)	1	
29	NPS02765-UNIT	FLX RETAINING RING 38 (SY-GB3438)	1	
30	NPS02766-UNIT	FLX RETAINING RING 55 (SY-GB2755)	1	
31	NPS02769-UNIT	FLX BEARING ZNKI40 (SY-ZNKI40)	1	
32	NPS02840-UNIT	FLX BEARING 61808 (SY-ZC61808)	1	
33	NPS02841-UNIT	FLX BLADE LIFTING RING (SY-L1063)	1	
34	NPS02842-UNIT	FLX WASHER (SY-WB209)	1	
35	NPS07218-UNIT	FLX SOCKET HEAD SCREW M10X30 (SY-GB021030)	1	

Drive System - Assembly / Service Kit

Item No.	Product Code	Description	Qty	Remarks
AS-1	NPS02869-UNIT	FLX BELT GUARD KIT AY (SY-FP424-BGKIT)	1	Inc Items: 1-2, 6-9

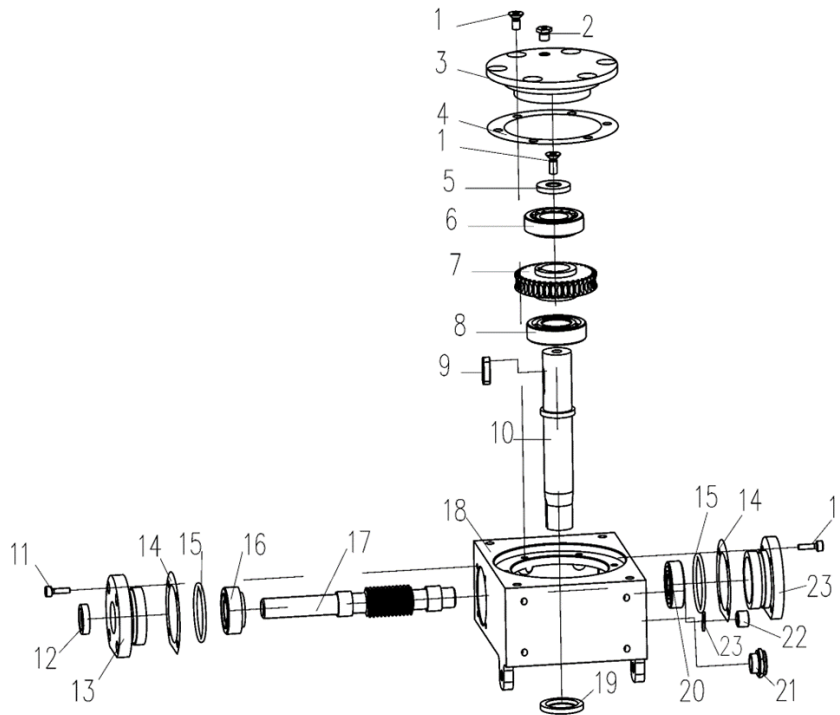

Gearbox

Item No.	Product Code	Description	Qty	Remarks
1	NPS07211-UNIT	FLX SOCKET HEAD SCREW M8X20 (SY-GB030820)	7	
2	NPS07207-UNIT	FLX AIR VALVE (SY-GB3210-Q2Q11)	1	
3	See Remarks	FLX COVER (SY-L1064)	1	Use AS-1
4	See Remarks	FLX PAPER GASKET (SY-WB635)	1	Use AS-1
5	See Remarks	FLX WASHER (SY-L1065)	1	Use AS-1
6	See Remarks	FLX BEARING 30206-2RZ (SY-ZC30206)	1	Use AS-1
7	See Remarks	FLX WORM GEAR (SY-WB368)	1	Use AS-1
8	See Remarks	FLX BEARING 6206 (SY-ZN6206)	1	Use AS-1
9	See Remarks	FLX KEY 8X28 (SY-GB220828)	1	Use AS-1
10	See Remarks	FLX WORM SHAFT (SY-WB367)	1	Use AS-1
11	NPS01902-UNIT	FLX SOCKET HEAD SCREW M6X20 (SY-GB020620)	8	
12	NPS07195-UNIT	FLX OIL SEAL 20X32X7 (SY-GB30203207)	1	
13	See Remarks	FLX BEARING COVER (SY-L1066)	1	Use AS-1
14	See Remarks	FLX PAPER GASKET (SY-WB634)	2	Use AS-1
15	NPS07188-UNIT	FLX RUBBER SEAL (SY-GB255531)	2	
16	See Remarks	FLX BEARING 30204-2RZ (SY-ZC30204)	1	Use AS-1
17	See Remarks	FLX WORM (SY-WB369)	1	Use AS-1
18	See Remarks	FLX GEARBOX CASE (SY-L1067)	1	Use AS-1
19	See Remarks	FLX OIL SEAL 30X45X7 (SY-GB30304507)	1	Use AS-1
20	See Remarks	FLX BEARING 6204ZZ (SY-ZN6204ZZ)	1	Use AS-1
21	See Remarks	FLX SIGHT GLASS M20X1.5 (SY-GB312015)	1	Use AS-1
22	NPS07208-UNIT	FLX OIL PLUG 18X1.5X 10 (SY-WB626)	1	
23	See Remarks	FLX BEARING COVER (SY-L1068)	1	Use AS-1
24	NPS02317-UNIT	FLX COPPER WASHER 18X24X2 (SY-GB182402-Q8)	1	

Gearbox -Assembly / Service Kits

Item No.	Product Code	Description	Qty	Remarks
AS-1	NPS02844-UNIT	FLX GEARBOX AY (SY-B220)	1	Inc Item 1-23

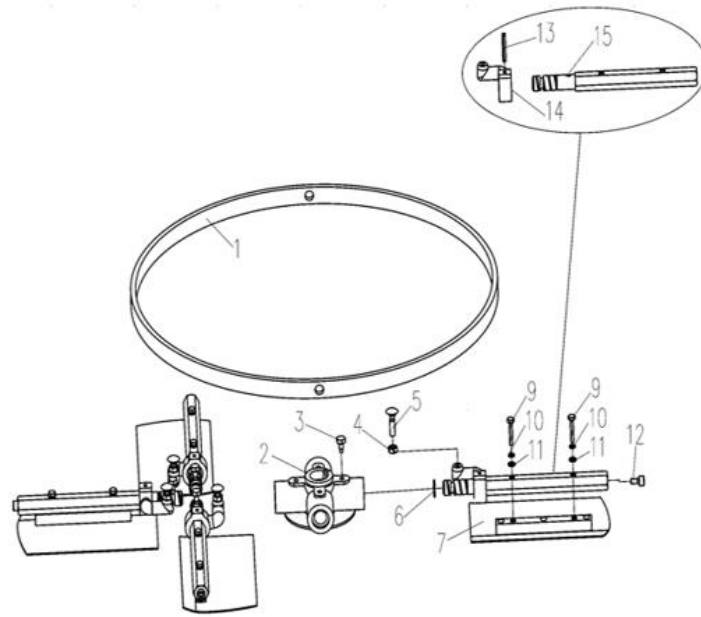

Spider Plate

Item No.	Product Code	Description	Qty	Remarks
1	NPS02849-UNIT	FLX STABILIZER RING (SY-L1069)	1	
2	NPS02843-UNIT	FLX SPIDER PLATE (SY-L1070)	1	
3	NPS02294-UNIT	FLX SCREW M10X20 (SY-GB141020)	4	
4	NPS01206-UNIT	FLX HEX NUT M8 (SY-GB0808-Q6)	4	
5	NPS02295-UNIT	FLX SCREW M8X30 (SY-GB350830)	4	
6	NPS02845-UNIT	FLX O-RING (SY-GB252302)	4	
7	FT220455-UNIT	FLX COMBINATION BLADE (SY-L9014)	4	
9	NPS02848-UNIT	FLX HEX HEAD SCREW ¼" X 1½" UNC (SY-GB01062038-Q2)	8	
10	NPS02185-UNIT	FLX SPRING WASHER M6 (SY-GB1306)	8	
11	NPS02188-UNIT	FLX WASHER M6 (SY-GB1206)	8	
12	NPS02354-UNIT	FLX COMBINATION BLADE (SY-GB020812)	4	
13	NPS02158-UNIT	FLX PIN 5X40 (SY-GB240540)	4	
14	See Remarks	FLX MOUNT (SY-L1073)	4	Use AS-1
15	See Remarks	FLX TROWEL ARM EXTENDED (SY-L1074)	4	Use AS-1

Spider Plate- Assembly / Service Kits

Item No.	Product Code	Description	Qty	Remarks
AS-1	NPS02846-UNIT	FLX TROWEL ARM ASSY (SY-L1072)	4	Inc Items 13-15

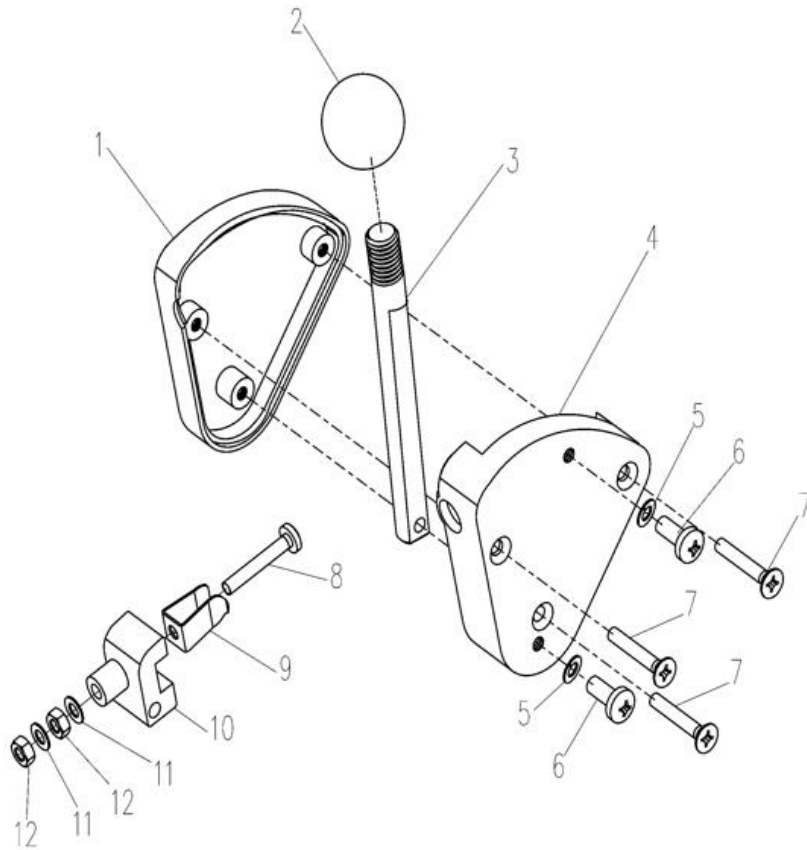

Safety Switch

Item No.	Product Code	Description	Qty	Remarks
1	See Remarks	FLX SAFETY SWITCH INNER COVER (SY-L1075)	1	Use AS-1
2	See Remarks	FLX SAFETY SWITCH KNOB (SY-WB197)	1	Use AS-1
3	See Remarks	FLX SAFETY SWITCH THROW ARM (SY-L1008)	1	Use AS-1
4	See Remarks	FLX SAFETY SWITCH OUTER COVER (SY-L1009)	1	Use AS-1
5	See Remarks	FLX WASHER FLAT M5 (SY-GB1305)	2	Use AS-1
6	See Remarks	FLX SCREW M5X10 (SY-GB150510)	2	Use AS-1
7	See Remarks	FLX BOLT CSK M4X25 (SY-GB160425)	3	Use AS-1
8	See Remarks	FLX BOLT M4X20 (SY-GB150420)	1	Use AS-1
9	See Remarks	FLX EARTH CONTACT (SY-L1010)	1	Use AS-1
10	See Remarks	FLX EARTH CONTACT SEAT (SY-WB201)	1	Use AS-1
11	See Remarks	FLX FLAT WASHER M4 (SY-GB1204)	2	Use AS-1
12	See Remarks	FLX NUT M4 (SY-GB0804)	2	Use AS-1
13	See Remarks	FLX SAFETY SWITCH CABLE (SY-R-436-0006)	1	Use AS-1

Safety Switch - Assembly / Service Kits

Item No.	Product Code	Description	Qty	Remarks
AS-1	NPS07245-UNIT	FLX CENTRIFUGAL SAFETY SWITCH ASSY (SY-BT-AQKG01)	1	Inc Items: 1-13



Flextool

1956 Dandenong Road, Clayton VIC 3168, Australia

Phone (AUS): 1300 353 986

flextool.com.au

ABN 80 069 961 968

This manual summarises our best knowledge of the product based on the information available at the time of publication. You should read this manual carefully and consider the information in the context of how the product will be used. Our responsibility for products sold is subject to our standard terms and conditions of sale.

DISCLAIMER:

Any advice, recommendation, information, assistance or service provided by us in this manual is given in good faith and is believed by us to be appropriate and reliable. However, any advice, recommendation, information, assistance or service provided by us is provided without liability or responsibility PROVIDED THAT the foregoing shall not exclude, limit, restrict or modify the right entitlements and remedies conferred upon any person or the liabilities imposed upon us by any condition or warranty implied by Commonwealth, State or Territory Act or ordinance void or prohibiting such exclusion limitation or modification. The product can be expected to perform as indicated in this manual so long as operation and operational procedures of the individual products are followed as recommended in this manual.

Design and technical specifications may be subject to changes.

© This publication is copyright. All rights are reserved. Flextool and Profinish are registered trade marks of Parchem Construction Supplies Pty Ltd.