



410-00801

REVERSIBLE SOIL COMPACTOR

**MVH-R60/100(120)/150**

SERVICE MANUAL



<http://www.mikasas.com>

# C O N T E N T S

1. Tools .....	1
2. Inspection Procedure .....	2
3. Engine, Oil and V-belt .....	2
4. General Rules for Conducting Service .....	3
5. Disassembly and Reassembly .....	4
5-1. Operation System .....	4
5-2. Basic Machine .....	8
5-3. Vibration System .....	9
5-4. Hand Pump System .....	19
6. Periodical Inspection and Maintenance Work .....	21
7. Trouble Shooting .....	26
8. Wiring Diagram .....	29

# 1. Tools

1. Wrench 10mm 12mm 13mm 14mm 17mm 19mm 22mm 24mm 27mm

Offset wrench/Socket wrench/Adjustable wrench

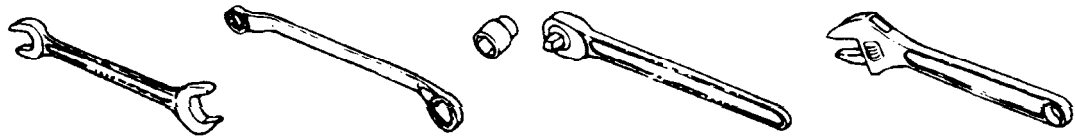

2. Hexagonal wrench 3/16inch  
5mm 8mm 10mm 14mm



3. Plier



4. External snap ring plier/Internal snap ring plier(bent type can be also used)



5. Screwdriver, flat and cross



6. Metal and plastic hammers



7. Pulley pu

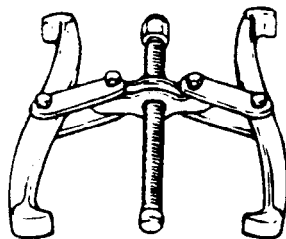

8. Sealing compound (Loctite 242, 271 and 638)



9. Liquid gasket



10. Pressing machine

## 2. INSPECTION PROCEDURE

### 1.External appearance check

- (1) Installation of parts (loosened screw, defective parts, etc.)
- (2) Damage on machine
- (3) Oil check (level and contamination)
  - a. Engine oil (SAE10W-30 when shipped) (See Table 1 for the capacity)
  - b. Vibrator
  - c. Hydraulic oil (forward and reverse)
- (4) V-belt for proper tension, damage, crack, hardening, etc.
- (5) Shock rubber for damage, crack, fatigue, hardening, etc.

### 2.Operating test

- (1) Engine
  - Engine speed check (Max. set rpm and idling)
- (2) Traveling
  - a. Check for selection of forward/reverse travel.
  - b. Check for speed of forward/reverse travel.
- (3) Check for abnormal noise during operation.

## 3. Engine, Oil and V-belt

Table 1

Type	MVH-R60	MVH-100(120)		MVH-150	
Mounted engine	HondaGX120	HondaGX160	RobinEH17	HondaGX200	RobinDY23(DS)
Set rpm (min <sup>-1</sup> )	3600	3600	3600	3600	3200
Fuel tank capacity (Liter)	2.5	3.6	3.6	3.6	3.2
Fuel consumption (L/h)	0.95	1.1	1.1	1.2	1.0
Engine oil capacity (L)	0.6	0.6	0.65	0.6	0.9
Vibrator oil capacity (L)	0.25	0.35	0.65	0.35	0.35
Lubrication oil in use	Engine Oil SAE10W-30				
Vibrator oil replacement interval (hours)	200				
Size and quantity of belt	RPF3320X1	RPF3320X1	RPF3320X1	RPF3350X1	RPF3340X1
Compaction	Forward	0~25	0~23	0~23	0~25
	Reverse	0~25	0~21	0~21	0~25
Hydraulic oil	Shell Tellus #46 or equivalent				

## 4. RULES FOR CONDUCTING SERVICE WORK

1. In order to avoid deficient reassembly, know normal status of installation before removing or disassembling any part. Level check or replacement of vibrator oil should be carried out on level ground.
2. Each time disassembly is made involving oil seal, gasket, packing, o-ring, lock washer or the like, be sure to replace them with new ones.
3. Mating surfaces of vibrator case and compaction plate should be sealed with liquid gasket (Clean and de-grease the mating surfaces thoroughly).
4. For tightening bolts and nuts, use the specified standard torque and bonding agent (Loctite or the like). For such bolts and nuts that are not specified, see Table of Tightening Torque. (Before coating with Loctite, clean the screw with gasoline or thinner.)  
**NOTE:** All the screw in use with this machine are right handed.

Table of Tightening Torque (kgf-cm)

Table 2

Screw diameter	6mm	8mm	10mm	12mm	14mm	16mm	18mm	20mm
Material								
4T(SS41)	70	150	300	500	750	1,100	1,400	2,000
6-8T(S45C)	100	250	500	800	1,300	2,000	2,700	3,800
11T(SCM3)	150	400	800	1,200	2,000	2,900	4,200	5,600
In case counter part is made from aluminum	100	300~350	650~700					

※For indication in SI Unit (International Unit System), use the conversion of 1kgf-cm=9.80665N-cm

5. Disassembly work should be conducted where it is free from dust.
6. Where bonding agent such as Loctite has been in use and screw is hard to loosen, heat it with torch lamp or the like. Such heated bolt must be replaced with new one, which is of high-tension type as specified.
7. Use proper tool in proper manner.

Hydraulic hose tightening torque: Screw size 1/4 380kgf-cm
--

## 5. DISASSEMBLING / REASSEMBLING THE MVH-R60~150:

### 5-1 OPEARTION SYSTEM (MVH-R60)

#### Disassembly

1. Removing two bolts (51) causes throttle body (37) and throttle lever (39) to come off as an assembly. Removing the double nut (46, 47) causes the throttle lever to come off the throttle body. For removing throttle lever off the machine, remove the throttle wire (50) which has been screwed down to the engine.
2. Removing bolt (18) causes the travel lever (17) to come off hand pump (16).
3. Remove hydraulic hose (26) from the elbow(35) of vibrator shown in the drawing of disassembled vibrator.

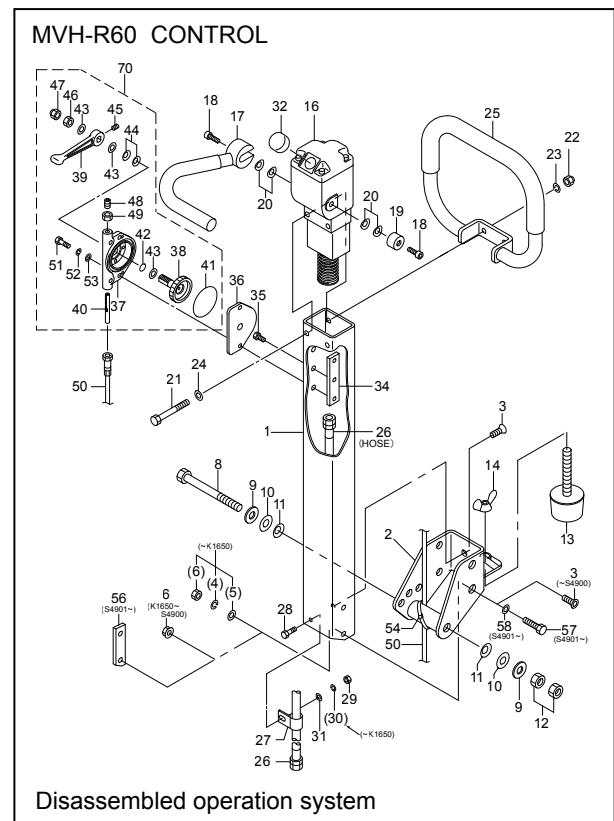

**NOTE** Whenever hydraulic hose has been disconnected, apply blank plug to it for prevention of any dust from entering.

Remove hydraulic hose clamp (27), its retainer bolt (28) and nut (29). Removing two bolts (21) and nuts (22) allows to remove grip (25) and hand pump (16) from handle (1).

4. Removing four bolts (28) shown in the drawing allows to remove the handle (1) from base.

#### Disassembly

Reassemble the system with its disassembly procedure reversed while observing below:

1. For installing the handle assembly (1) to the base, first have the four bolts (28) tightened only lightly which are fixing the handle bracket (R) and (L) (26, 27) in the developed drawing, and after adjusting resistance in handle operation by means of double nut (12), retighten them securely.
2. Have the throttle lever resistance adjusted with double nut (46, 47) before fixing the throttle lever (39) with socket head set screw (45). The nut tightening torque is 120kgf-cm.
3. Set rpm for high speed side of engine (See Table 1) should be adjusted by means of engine set screw on the engine side.

### Reassembling the governor lever assembly:

The governor lever assembly should be totally disassembled except for hollow setscrew (62) and nut M8 (63) (See Fig.A).

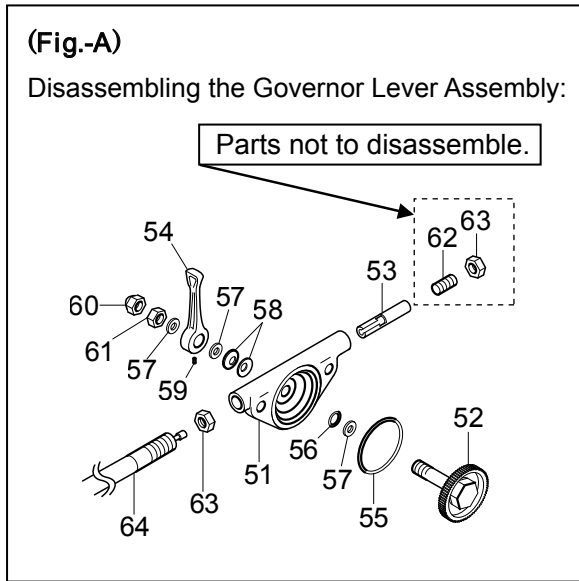

#### <NOTE:1>

Disassembled hollow setscrew(62) and thin nut M8(63) should be reassembled to be flush with each other as shown in Photo B and C

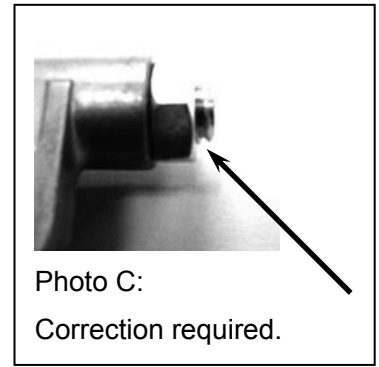

### Reassembling Procedure:

1. Insert the slider(53) into throttle body(51) with its groove coming in the back (Photo D)

2. Install the outer governor wire (64). (Photo E)  
(In case the end of inner governor wire should be bent, install inner and outer wires together by taking measures of steps 3 and 4 below to get the result as shown in Photo H.)

3. Insert inner part of governor wire(64) through throttle body(51) (Photo F and G)

4. While pulling the end on inner wire which has come out of outer part of governor wire, rotate it so that the gear teeth of slider is visible. (Photo H)

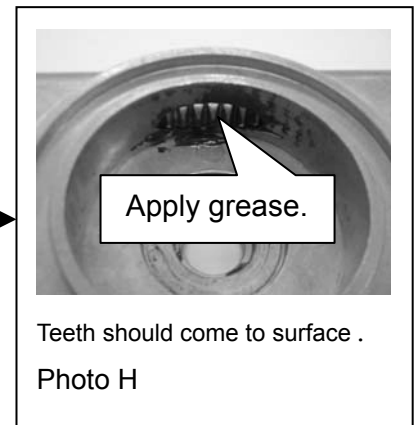
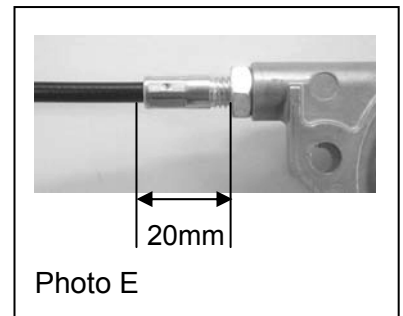
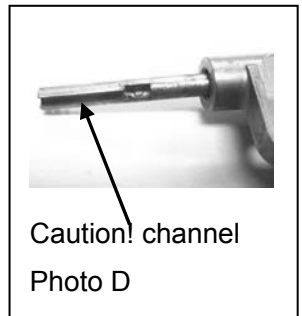

5. Assemble plain washer (57) and o-ring (56) to throttle gear (Photo I).

Tooth face of throttle gear, plain washer and o-ring should be coated with grease.

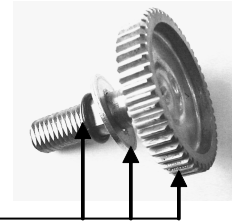

Photo I :  
Throttle gear, etc.

6. Assemble throttle gear(52) to throttle body(51) as follows:

- a. Push-in the governor wire(inner) and shift the slider(53) all the way to the back (Photo J).
- b. Install with triangle mark of the throttle gear coming on top (Photo K).



Photo J :  
Pull the inner part.

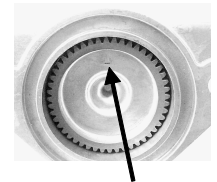

Photo K :  
Triangle mark

7. Assemble throttle lever(54) to throttle body(51) (Photo L and M)

\* Plain washers should be installed facing each other.

\* Tightness of throttle lever should be adjusted with nut M10 and cap nut M10.

To increase resistance in the movement of throttle lever, add a plain washer M10 on the back end.

**Tightening torque: 120kgf-cm**

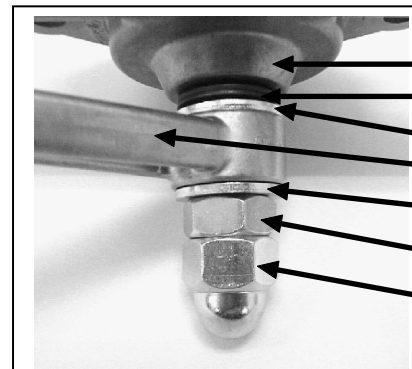

- Throttle body (51)
- Belleville spring (58) x 2
- Plain washer M10 (57)
- Throttle lever (54)
- Plain washer M10 (57)
- Nut M10 (61)
- Cap nut M10 (60)

Photo L :  
Assembling the lever

\* Turn-in the hollow setscrew(59) to lock the throttle lever to throttle gear.

After assembling, throttle lever stops when it reaches top position as shown in Photo M.

This is the position for the maximum engine rpm.

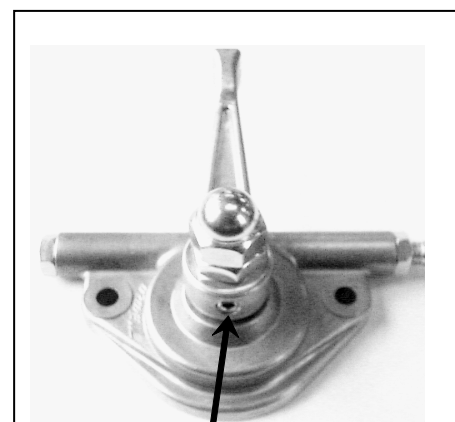

Photo M :  
Hollow setscrew



## 5-1 OPEARTION SYSTEM (MVH-100/120)

### Disassembly

1. Removing two bolts(26) allows to remove the assembly of grip(25), lever bracket(33) and throttle lever(35).  
Removing double nut(36, 37) causes throttle lever(35) to come off the lever bracket(33).  
To remove throttle lever from machine, remove governor wire which has been crewed down to engine.
2. Removing the bolt(13) allow to remove travel lever(12) from hand pump(11).
3. Remove hydraulic hose(19) from the connector(34) of vibrator shown in the drawing of disassembled vibrator.

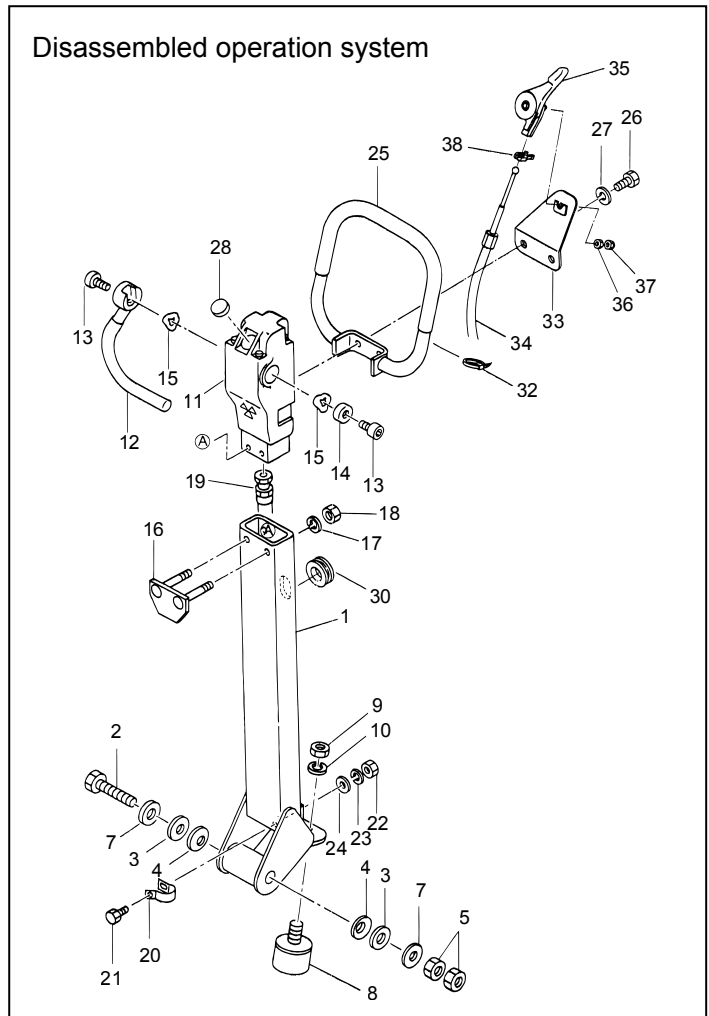

**! NOTE:** After removing hydraulic hose, apply blank cap to prevent any dust from entering.

Removing hose clamp(20), its mounting bolt(21), hand pump locking nut(18) and two stud bolts (pump)(16) allows to remove the hand pump(11) from handle(1).

4. With the two handle root mounting double nuts (5) removed, taking off the bolt(2) allows to remove the handle(1) from the base.

### Reassembly

Reassembly should be conducted with the disassembling procedure reversed while observing below:

1. For installing the handle assembly(1) to the base, first lightly tighten the nut and bolt which have been tightening the guard hook side of the machine and adjust the resistance of handle movement by means of double nut(5) before retightening.
2. Resistance of handle movement should be adjusted with double nut(36,37)
3. Set rpm of the engine on the high speed end should be adjusted on the engine side by means of engine setscrew.

\* Disassembly and reassembly procedures for MVH-150 is identical to those of MVH-100/120.

## 5-2 BASIC MACHINE <Common to MVH-R60, 100 (120) and 150>

\* MVH-R60 is used as an example here.

### Disassembly

1. With four bolts (21) removed, take off the outer belt cover (20).
2. Remove V-belt(16).
3. With bolt(15) removed, withdraw the clutch (12).
4. With flat head screw(18) removed, take off dust cover(17). (Base can be separated from vibrating plate even without performing the steps 3 and 4.)
5. Remove hydraulic hose which has been connected to vibrator.

Before removing the hydraulic hose, remove mud or any other smear from the joint area.

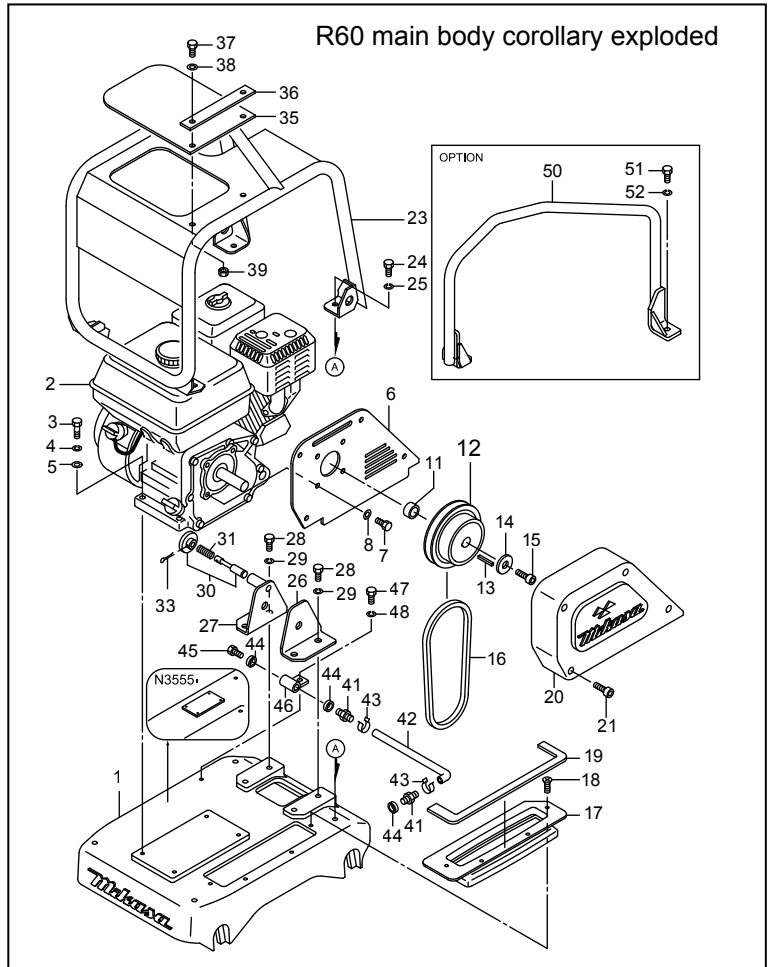

6. After removing four bolts which have been fixing isolation rubber to the base(1), lift the base assembly upward. The vibrating plate assembly will be separated.

### Reassembly

Reassembly should be conducted with the disassembly procedure reversed, while observing below:

1. Coat the bolts and nuts for mounting the shock adsorber with Loctite 242.
2. All the mounting bolts for the basic machine should be coated with Loctite 242.
3. Installation of the clutch should be made with the belt groove coming to the engine side.

## 5-3 VIBRATION SYSTEM

During disassembly and reassembly work, use care not damage any parts.  
O-ring, oil seal, packing or the like must be replaced with new one.

### Disassembly<Common to MVH-R60, 100 (120) and 150>

\*MVH-R60 is used as an example hereunder.

1. Remove any hydraulic hose connection.
2. With vibrator case mounting bolts(46,47) removed, separate the vibrator case assembly from vibrating plate(See Fig.1)
3. With four bolts(30) removed, remove cylinder(29).

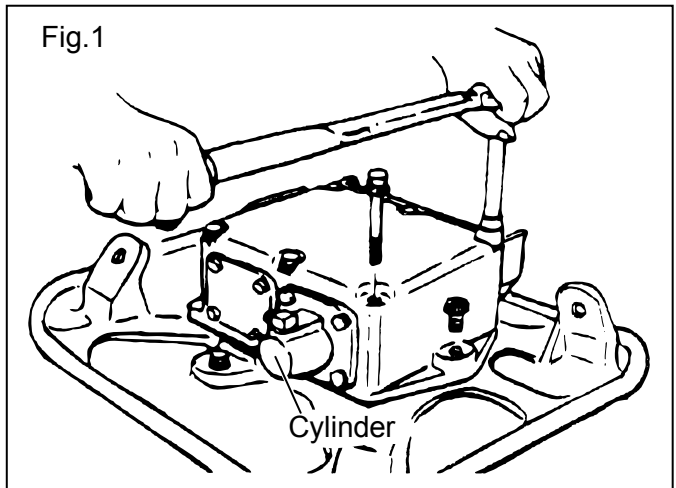

#### 4. Disassembling the piston:

- 4-1. With the vibrator case inverted upside down, rotate gear in either direction to cause the piston assembly(15) to be projected from the vibrator case, before removing the expansion stop ring(17) from inside of the piston.(Use a bent nose type stop ring plier for this purpose.) (See Fig.2)

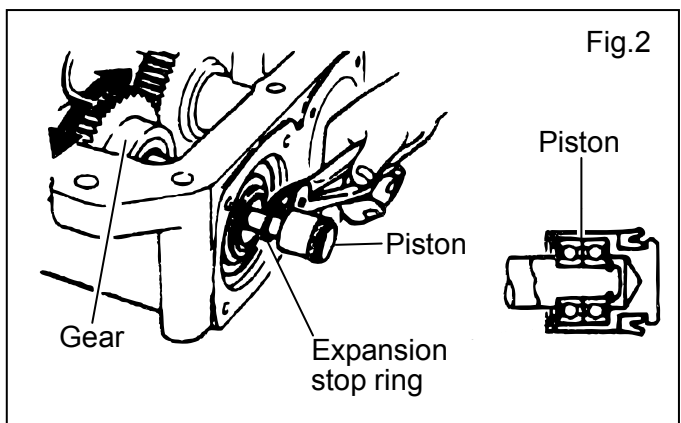

- 4-2. Withdraw the piston.

- 4-3. With the contraction stop ring(14) removed, take off bearing(13) and expansion stop ring(17) which had been removed earlier(See Fig.3).

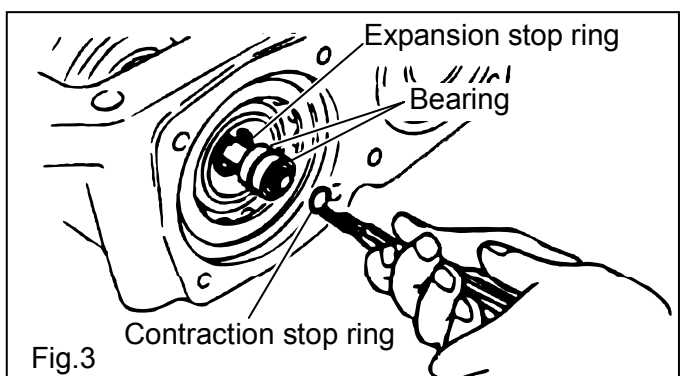

MVH-R60  
VIBRATOR

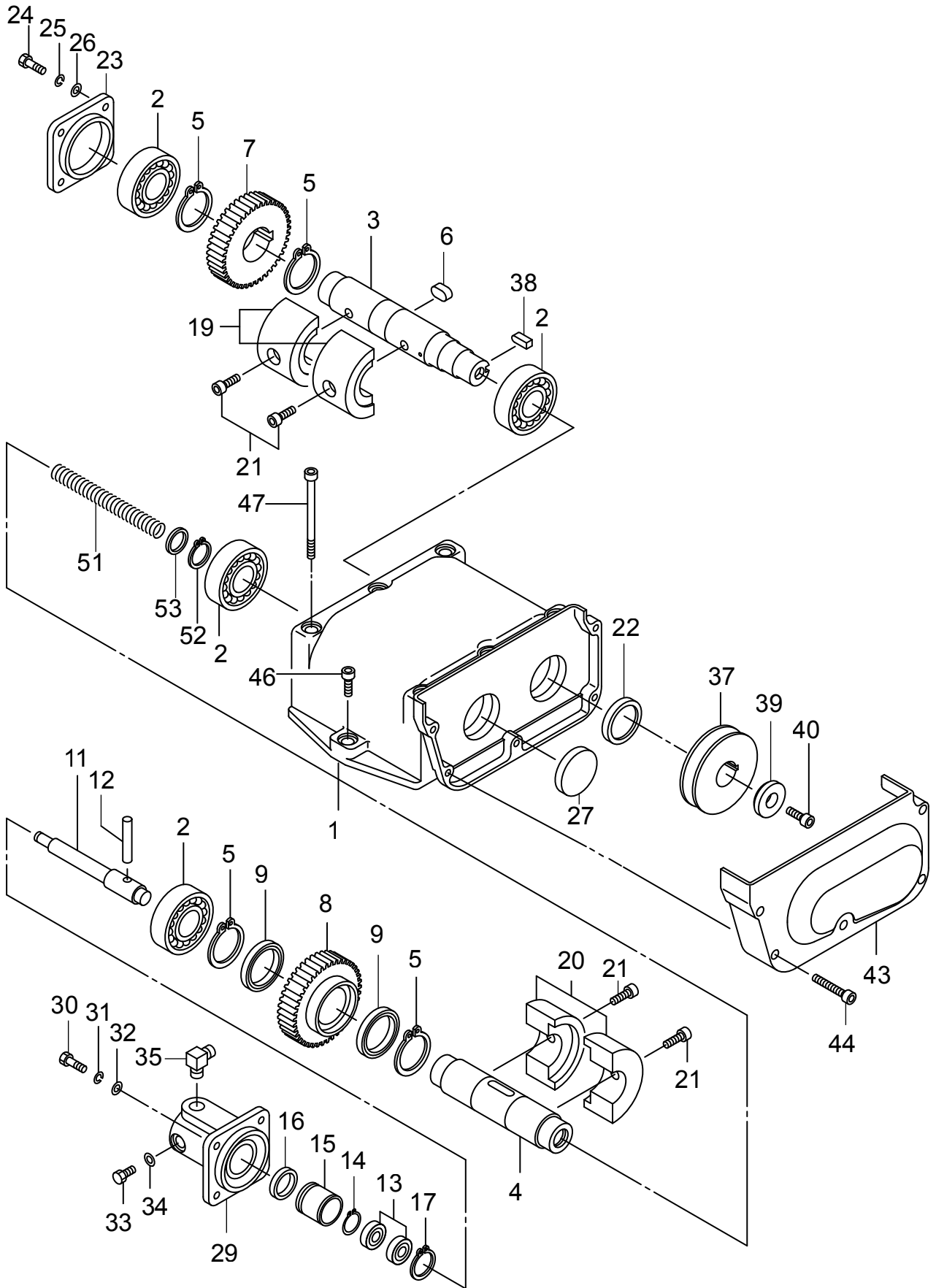

## <MVH-R60>

4-4. Remove seal cap(27).

Remove pendulums(19, 20) from each pendulum shaft(See Fig.4)

4-5. lum shaft(See Fig.4)

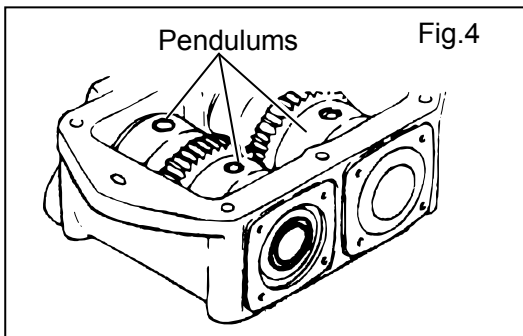

4-6. Shift the pendulum(driven shaft side)(4) to one side of the vibrator case(1) and remove bearing(2) using the pulley puller, before removing the pendulum assembly from the vibrator case(See Fig.5).

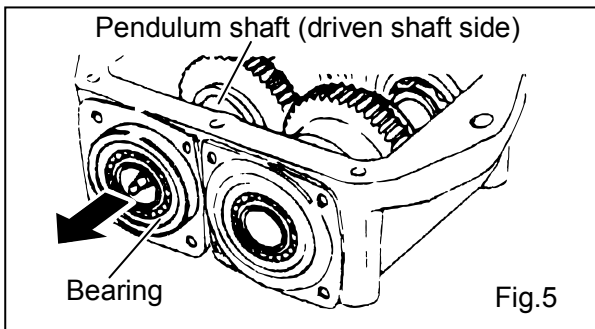

4-7. Push out the stop ring(5) and gear(driven shaft side) to one side and pull it out. If the gear is hard to remove, use the press rather than tapping on it with hammer.(See Fig.6)

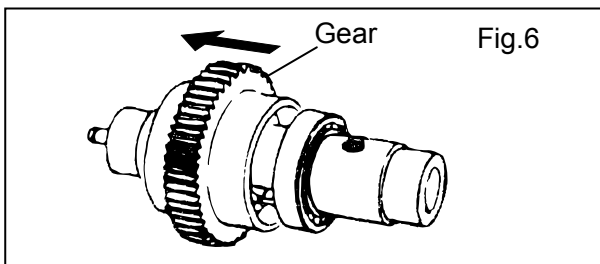

4-8. Push the knock pin(12), with your finger or by using a plastic hammer if it is sticky, which will allow to pull out piston rod(11) from the pendulum shaft(See Fig.7).

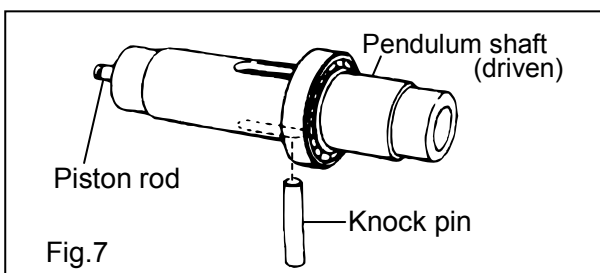

## <MVH-100 (120) AND 150>

4-4. Remove seal cap(25).

4-5. Remove pendulums(18) from each pendulum shaft(See Fig.8)

4-6. With the driven shaft assembly pushed out to the side opposite to pulley and the bearing(2) taken out, remove the driven shaft assembly from the vibrator case(See Fig.8).

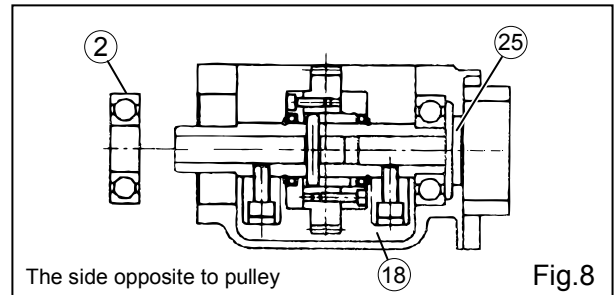

4-7. Disassembling the driven shaft:  
Remove four mounting bolts(10) and take out bearing holder(8)(See Fig.9).

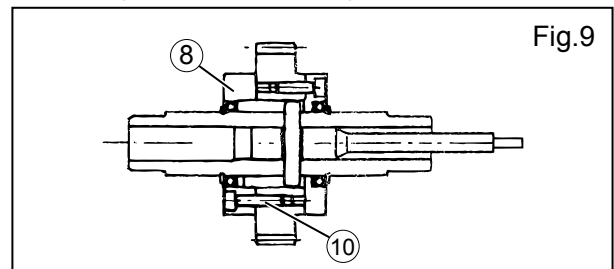

4-8. Remove four mounting bolts(44) and driven gear(31). Tap on and remove parallel pin(12) before pulling out piston rod(11) from driven shaft(4)(See Fig.10).

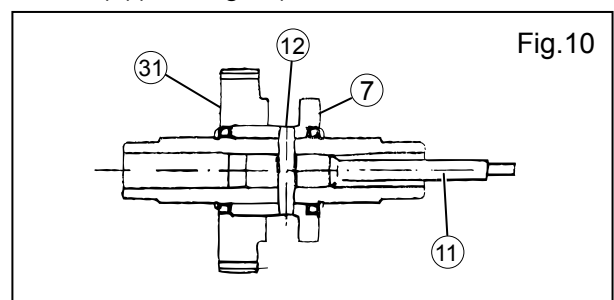

4-9. With two contraction stop rings(5) removed, remove 210° cam ring(7) from driven shaft(4) before removing bearing(9) as well(See Fig.11).

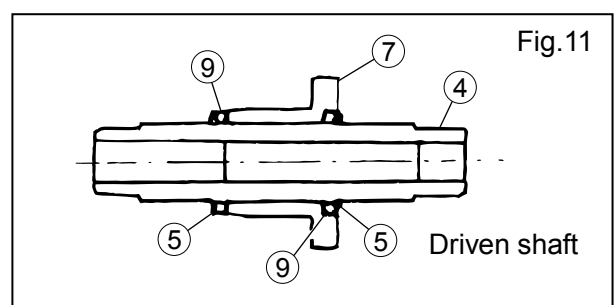

MVH-100(120) / 150  
VIBRATOR

1. Models MVH-100(120) and MVH-150 are different with respect to bearing(2), pendulum(18), hex socket head bolt(19), pendulum pulley(35), belt cover (lower) (45) and mounting socket head bolt(46).

2. For MVH-150, three different types of pendulum pulleys(35) are available according to engine model.

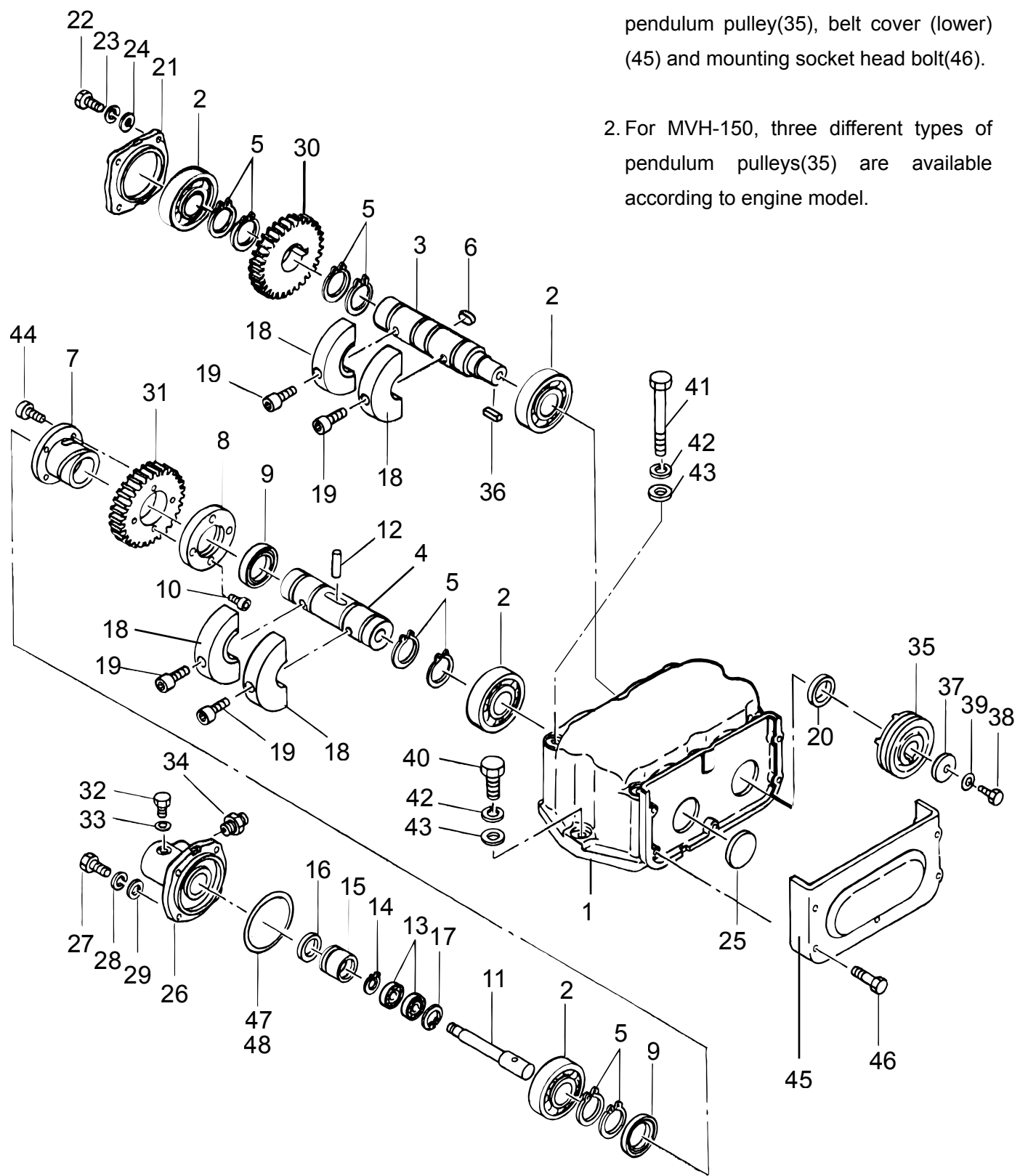

## <Common to MVH-R60, 100 (120) AND 150>

\*MVH-100(120) is used as an example here.

### Disassembling the driving shaft side:

- 5-1. With its mounting bolt(38) removed, pull out the pendulum pulley(35) from drive shaft. Have the key(6) removed as well(See Fig.12).
- 5-2. With its four mounting bolts removed, remove the bearing cover(21)(See Fig.12).
- 5-3. With its four mounting bolts removed, remove pendulum (18) and push out the drive shaft assembly to the bearing cover side before removing the bearing(See Fig.12).
- 5-4. As shown in Fig.13, remove upper stop ring(5) and engage supports between the drive gear (30) and inner surface of vibrator case. Press the drive shaft from top and remove drive gear within the vibrator case. The gear having been pressed-in over the distance of about 2cm, its removal will be easy beyond that point.
- 5-5. Pull out the drive shaft from vibrator case.

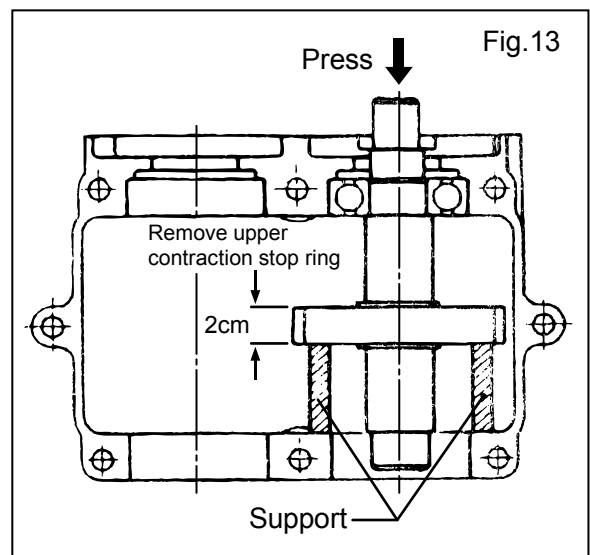
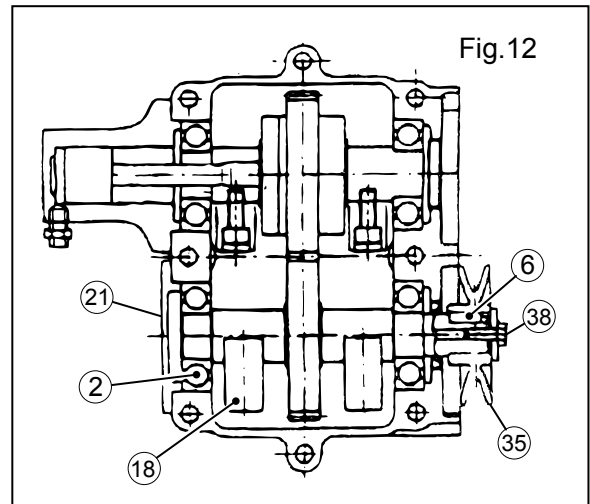

# REASSEMBLY

## <Common to MVH-R60, 100 (120) AND 150>

- Jigs to be used (3 types)

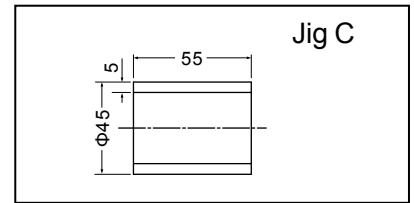
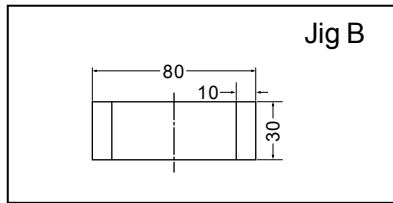
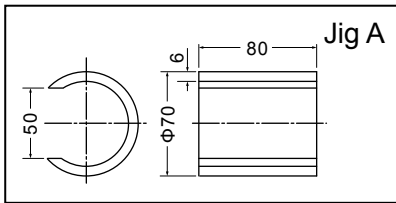

- Before proceeding with reassembly, remove liquid packing thoroughly from mating surface of vibrator case and compaction plate. Clean and de-grease all the other parts as well.

- Coat the press-fit area with molybdenum grease.

### Re-assembling the driving shaft:

1. Have both of the two bearings(2) inserted in the belt side of vibrator case(1) (See Fig.14).

#### Bearings in use:

MVH-R60:	6206C4
MVH-100(120):	6307C4
MVH-150:	NJ307MC4

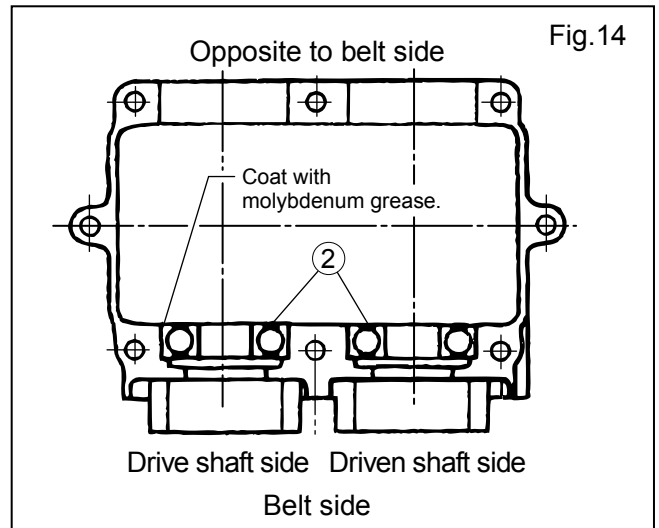

2. Within the vibrator case, press the drive gear(7) into drive shaft(3) with its punched side coming to top(Opposite to belt side) (See Fig.15).

- 2-1. Vibrator case is to be supported by means of Jig B with its belt side coming to bottom.

- 2-2. Have the key 10x8x19(6) and upper (opposite to belt side) stop ring(5) engaged to drive shaft. After placing such assembly inside the vibrator case, have the drive gear(7) (with its punched side coming to top) and stop ring(5) engaged to halfway of the drive shaft, in such order.

- 2-3. With the Jig A arranged as shown in Fig.15, push the drive gear into drive shaft by means of press and engage the lower stop ring(See Fig.16).

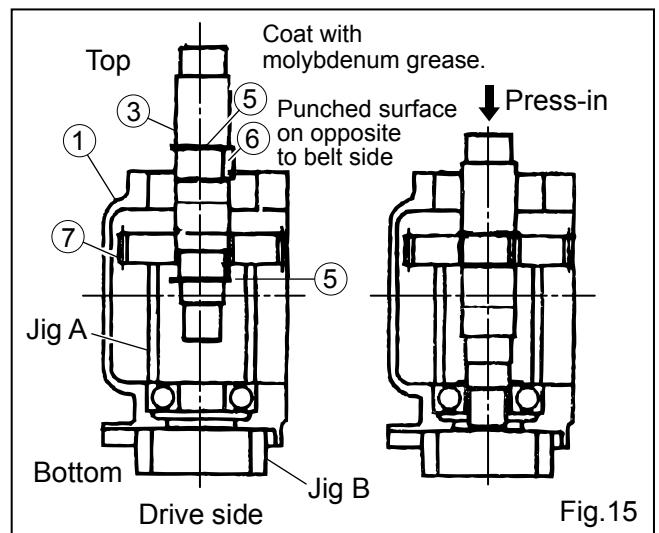

- 2-4. Press the bearing of opposite to belt side(2) into drive shaft(See Fig.17).

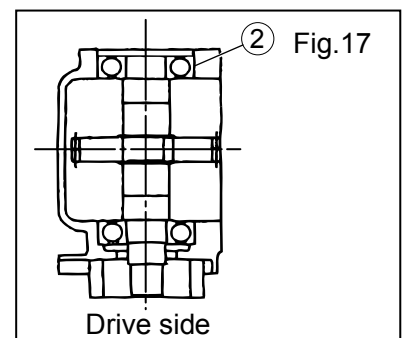
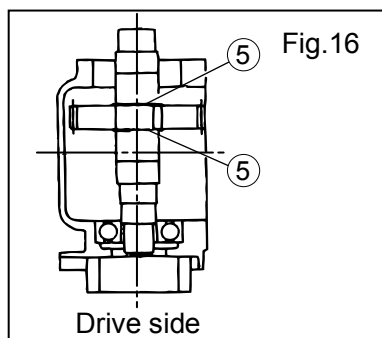



## Reassembling the driven shaft: <MVH-100 (120) and 150>

1. Insert 210° cam ring(7) to drive shaft(4). Pay attention to the direction of flange face to install.(See Fig.18)

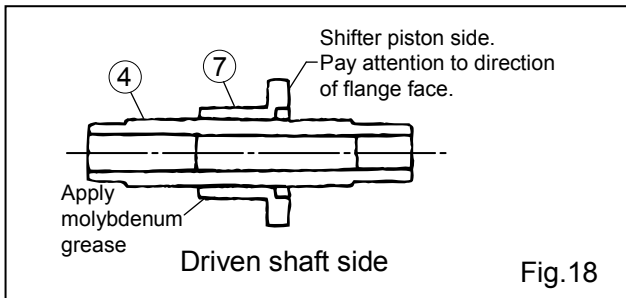

2. Insert two bearing 6807(9) to driven shaft from its each end and retain them with stop ring S-35(5). Apply flat screw drive blade and lightly tap on it to make sure that the stop ring has seated in the groove properly.

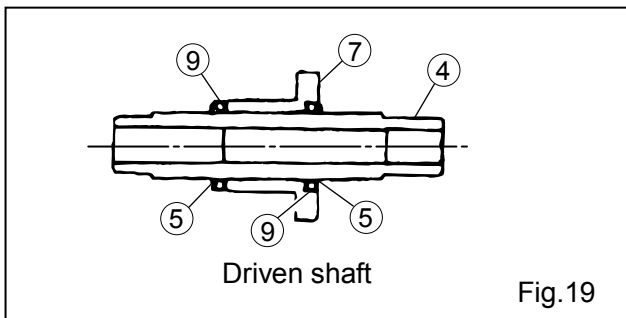

3. Insert piston rod(11) to the driven shaft (See Fig.20).
4. Press the parallel pin(12) via cam ring into piston rod. After pressing it in,make sure that the parallel pin dose not protrude from periphery of the cam ring.(See Fig.21)
5. After inserting driven shaft gear(31) to cam ring(7), lock it with four hex socket head bolts 6×20(44). Driven shaft gear(31) and cam ring should be aligned with punch marks as shown in Fig.23.

Bolts should be coated with Loctite 271.  
Tightening torque: 180kgf-cm

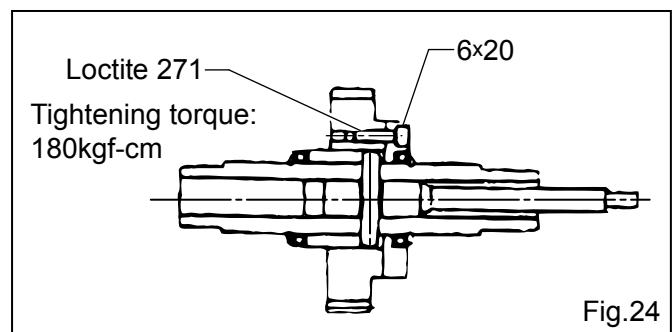
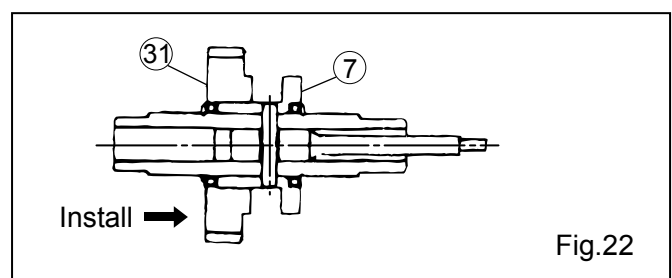
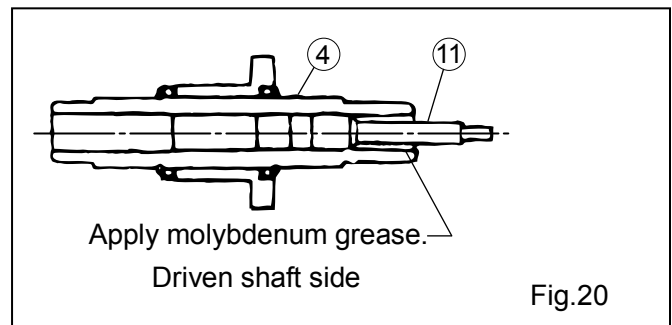
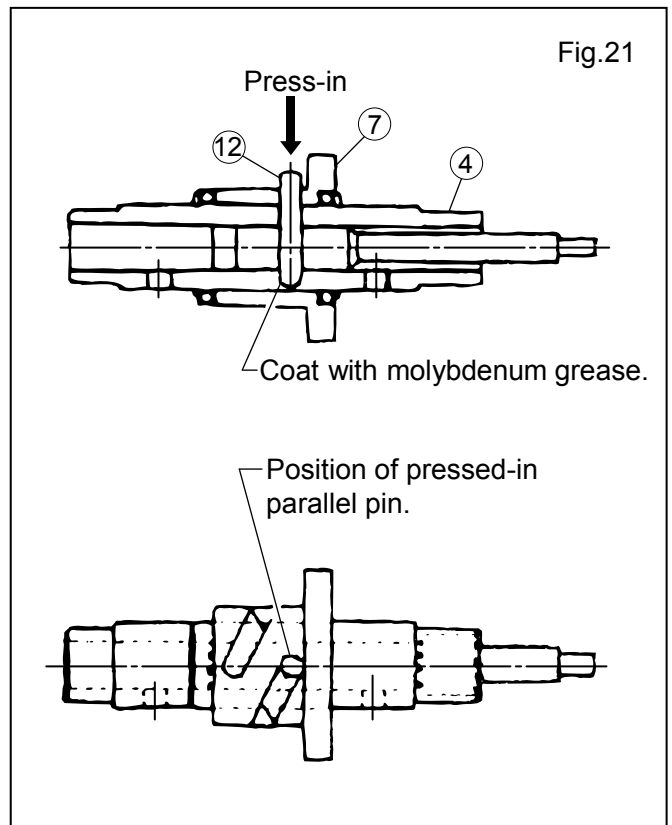
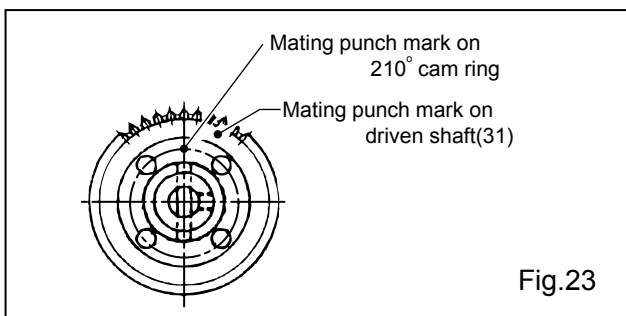

**Reassembling the driven shaft:  
<MVH-100 (120) and 150>**

6. Install bearing holder(8) to driven shaft gear with four hex socket head bolts 6x30(10). (See Fig.25)

Apply Loctite 271 to the bolts.  
Tightening torque: 180kgf-cm

7. Fit the driven shaft assembly to vibrator case and after aligning the punch marks of drive gear(30) and driven gear(31), insert it to bearing(2). (See Fig.26 and 27.)

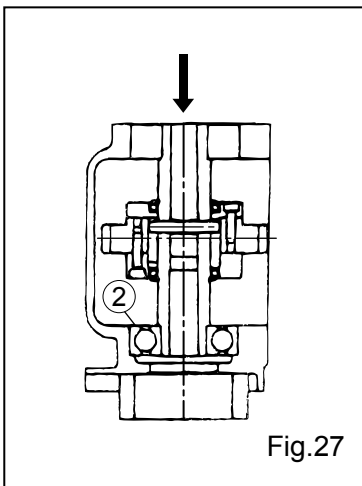
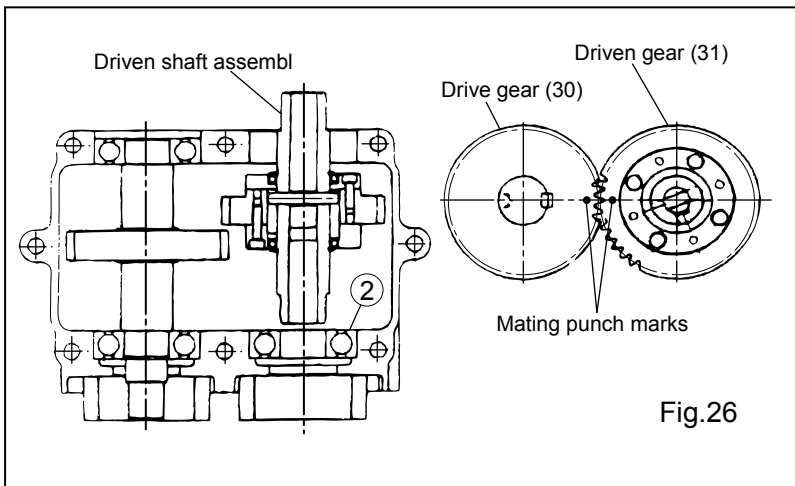
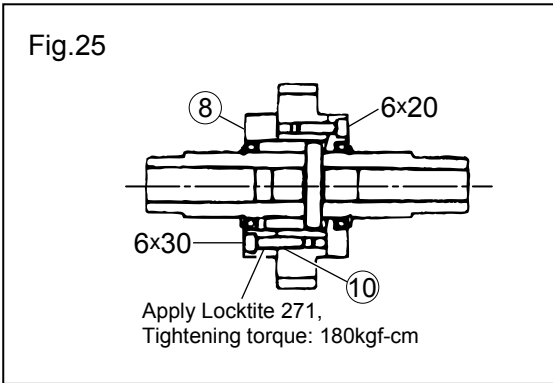

**<MVH-R60>**

1. Fit the piston rod to driven shaft, penetrate knock pin through center hole and push the gear to the middle of driven shaft before inserting bearings from each side (See Fig.28).
2. Install the stop ring (See Fig.28)

**!NOTE:**  
When inserting driven gear to driven shaft, make sure to align the punch mark of gear with pendulum installing position of pendulum shaft, before placing the knock pin in the spiral groove.  
Installing with the phase displaced by 180°, will cause operation of forward and reverse travel to be reversed. Also make sure that piston rod and gear are installed in proper direction.

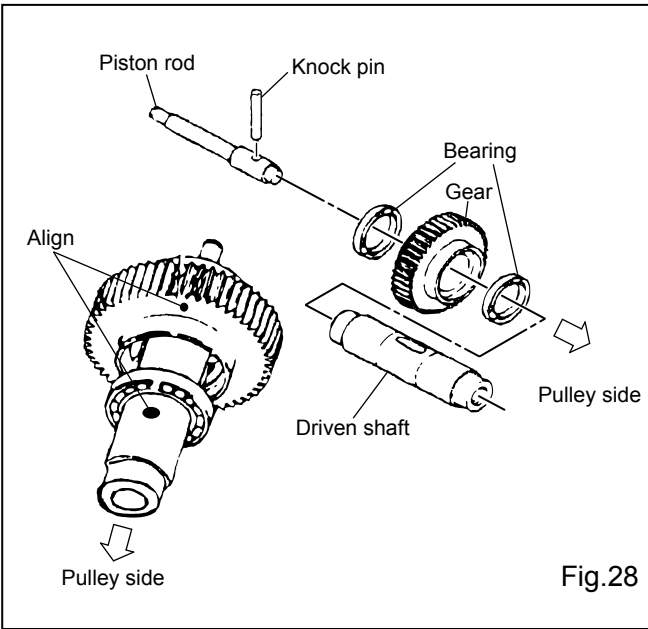

Be sure to apply molybdenum type extreme pressure grease sufficiently to the bore of pendulum shaft, piston rod, spiral portion of the bore of gear, before assembling.

## Reassembling the piston:

<Common to MVH-R60, MVH-100 (120) and 150>

1. Have the expansion stop ring installed over the piston rod and insert two bearings before retaining it with contraction stop ring (See Fig.29). (When using single shield type bearing, it should be installed with its seal surface facing outward.)

- When using commercially available bearing, use molybdenum extreme pressure type grease to pack.

- Apply grease to the area of piston rod where bearing is inserted.

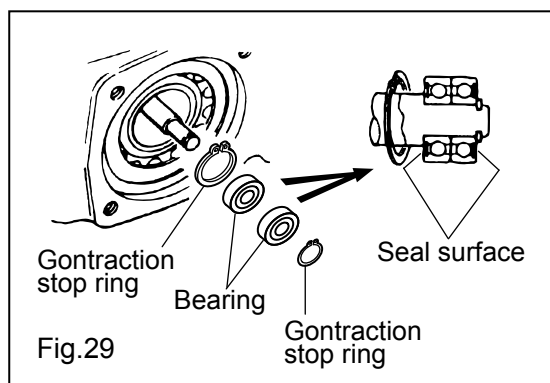

2. Install USH packing to piston. (See Fig.30.)  
(Push it in with your finger after coating with oil.)

- Make certain that piston has no scar or scratch.

- Use care not to damage piston.

- Install packing in proper direction.

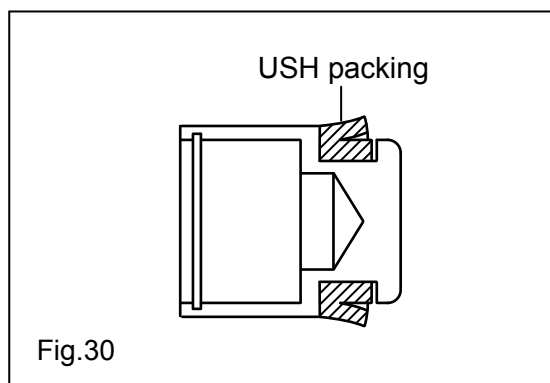

3. Place the piston over the bearing and push the assembly into vibrator case, before retaining it with the expansion stop ring which had been installed earlier (See Fig.31).

- To install the piston, either push it in with hand or lightly tap on it with plastic hammer.

- When installing the expansion stop ring, use bent nose type plier and make sure that it has seated properly in the groove.

- After installation, make sure that the piston rotates smoothly.

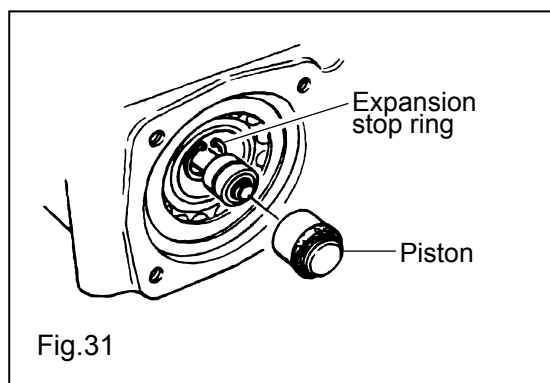

**Assembling the cylinder to vibrator case:  
<Common to MVH-R60, MVH-100 (120) and 150>**

Install o-ring to the cylinder and coat it with grease. (See Fig. 32)

- Coat the cylinder mounting bolt with Loctite #242.  
Tightening torque: 350kgf-cm
- When inserting piston into cylinder, use sufficient care not to damage UHS packing.

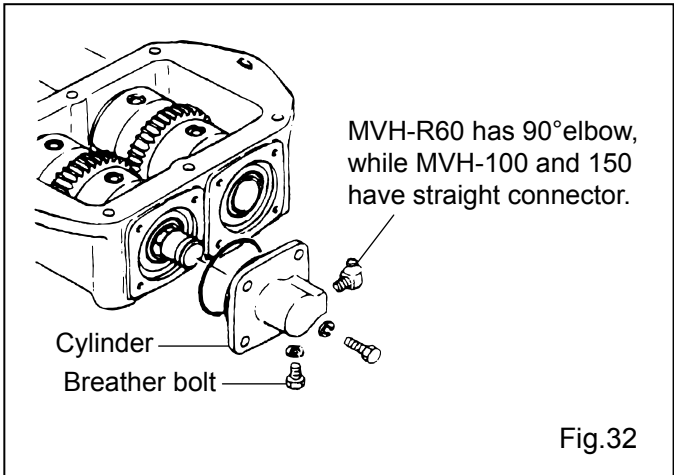

Fig.32

1. Install straight connector or 90°elbow and breather bolt (See Fig.32).

- Bandage straight connector or 90°elbow with sealing tape and position the elbow so that its tip points into vibrator.

2. Install bearing cover to cylinder side of vibrator case. Apply liquid packing (Three Bond 1215 or equivalent) to the thickness of about 0.5mm.
3. That completes the reassembly of vibrator but make certain that it rotates smoothly by turning its pendulum shaft (drive shaft) manually.  
If resistance is great, tapping on the gear side with plastic hammer lightly will help the rotation to be smooth.

- Do not possibly tap on the gear tooth.

4. Install the vibrator assembly to compaction plate. Thoroughly degrease the mating surfaces and coat the plate with liquid packing (Three Bond 1215 or equivalent) to the thickness of about 0.5mm on the plate side.

- Apply Loctite #242 to bolts. Tightening torque: 1,200kgf-cm (M12)
- Tighten bolts alternately in diagonal order.

5. After the liquid packing has hardened (in about 15 to 16 hours), feed oil to the vibrator.

- Type of oil: Engine oil SAE10W-30
- Capacity: MVH-60R: 0.25 Liter  
MVH-100 (120): 0.35 Liter  
MVH-150 0.35 Liter

## 5-4 HAND PUMP SYSTEM

### Disassembling/reassembling the hand pump:

\* In this Section, for the case where index numbers in drawings are different for MVH-100(120)/150 and MVH-R60, those for MVH-100(120)/150 will be shown in “{ }”.

#### 1. Removing the hand pump:

- 1-1 Disconnect hydraulic hose off the compactor cylinder.
- 1-2 Remove hydraulic hose clamp at the bottom of handle.
- 1-3 Remove hand pump assembly from the handle.
- 1-4 Remove hydraulic hose from the hand pump assembly.

#### 2. Disassembling the hand pump:

- 2-1 With breather cap (33,{22}) taken off, remove the breather (21).
- 2-2 Remove cover (2) from top of the pump (Remove four hex socket head bolts (21, {20})).
- 2-3 With blank plug (23, {17}) removed, take off the stopper (22, {16}).
- 2-4 With spring retainer (18) or hose joint ({19}) removed, take off the spring (16, 17,{14}).
- 2-5 With spring pin (6x25) (20,{13}) removed, take off control shaft (8,{7}) and cam (A).
- 2-6 Remove bush (9,{8}).
- 2-7 With stop plug (19,{18}) removed from the bottom of pump body (1), take off the piston (4) from the pump body (1).
- 2-8 In case of MVH-R60, piston spring (14) and cylinder (3) can also be removed from accumulator case (15).

#### 3. Clean the parts carefully:

(It is recommended to clean all the parts with paraffin in use.)

- 3-1 Clean the valve carefully which is contained inside the piston (4).
- 3-2 Clean the breather (21) thoroughly.
- 3-3 Clean the casing internals, being careful not to allow any dust to enter.

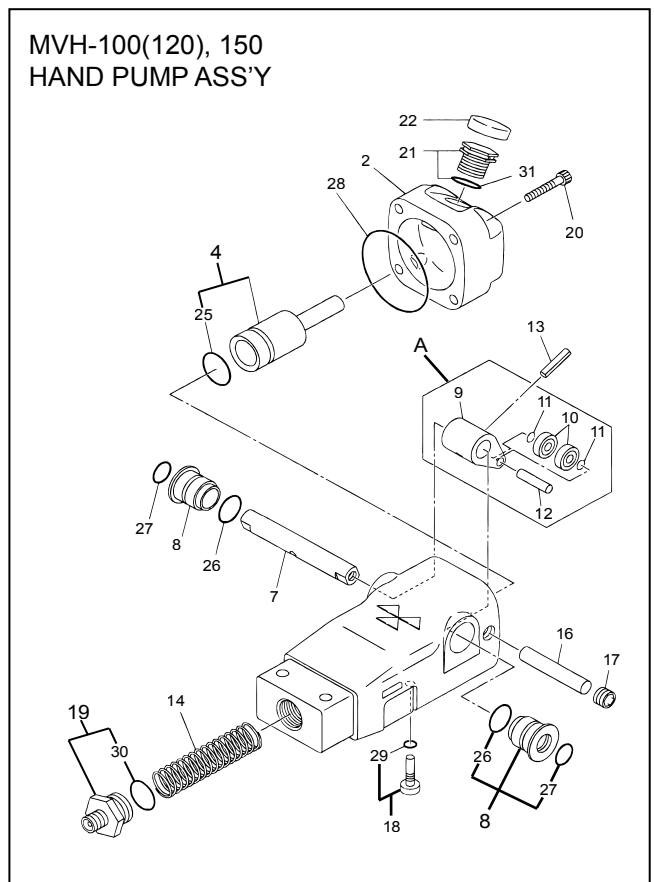
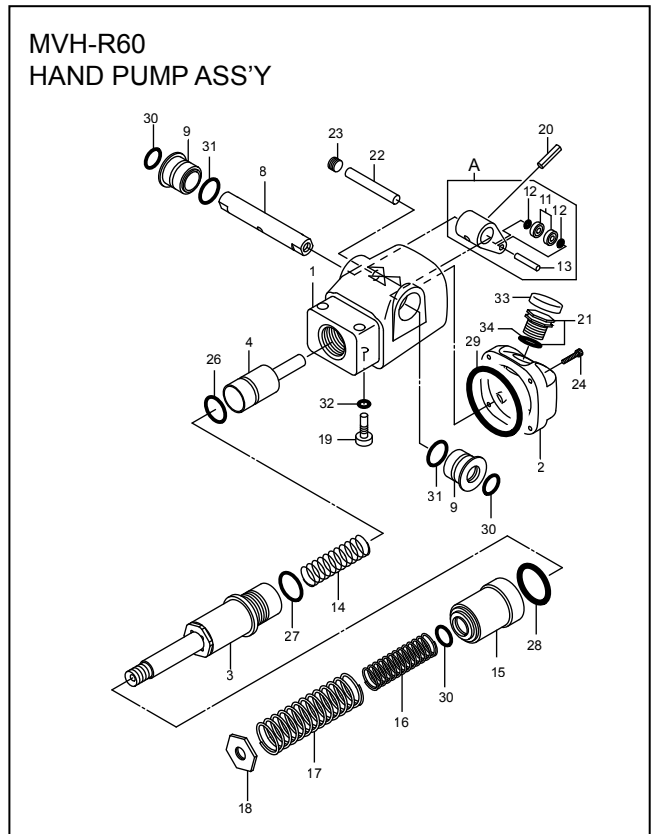

#### **4. Reassembling the hand pump:**

(All the O-rings should be renewed.)

- 4-1 Assemble piston CP (4) to pump body (1) and install stop plug (19, {18}). In case of MVH-R60, install accumulator case (15), piston ring (14) and cylinder CP (3) as well.
- 4-2 4-2 Within the pump body, insert control shaft (8,{7}) to cam COMP (A) and retain it with spring pin (20,{13}). Be sure to use bonding agent (Loctite 638) for installation of bush (9,{8}). inner O-ring (30,{27}), outer O-ring (31,{26}) as well as bush and pump body (1).
- 4-3 Insert stopper (22,{16}) and install blank plug (23,{17}).
- 4-4 Insert spring (16, 17, {14}) and install spring retainer (18) or hose joint ({19}).
- 4-5 Assemble cover (2) with hex socket head bolts and install breather (21) as well as its cover.

#### **5. Install the hand pump to the machine and conduct test run:**

- 5-1 Connect hydraulic hose to the hand pump assembly and insert it into handle before locking it with necessary parts.
- 5-2 Fix the hydraulic hose to the handle with clamp and install the hose to the cylinder on vibrator side.
- 5-3 With breather bolt at the cylinder top loosened, remove cover (2) and fill the hose and cylinder with oil (#46: Hydraulic oil). Tighten the bolts after venting air.
- 5-4 With the handle erected, fill the hand pump assembly with appropriate amount of oil before reinstalling the cover (2).
- 5-5 After conducting test run, vent air again and check the oil tank of hand pump assembly for proper level.

### **TROUBLE DUE TO HAND PUMP AND REMEDY:**

- 1. Traveling deficiency due to dust entering piston CP:  
Remove and isolate the hand pump assembly from machine. With cover (2) removed and hydraulic oil drained, place travel lever in reverse position and invert the pump. Pour illuminating kerosine from hose joint (spring retainer) side to clean and blow off any dust with air pressure. Or, clean it by disassembling completely in such manner as shown above.
- 2. Traveling deficiency due to broken spring pin (20, {13}) inside the hand pump, such as caused by forcibly operating the travel lever when engine is not running:  
Replace the spring pin after cleaning the oil tank in hand pump assembly. Or, clean the tank and replace the spring pin by completely disassembling it as shown above.

## 6. PERIODICAL INSPECTION AND MAINTENANCE WORK

**⚠ NOTE:** Inspection or maintenance service should be conducted on hard and level ground. Be sure to have engine shutdown before starting such inspection or service work.

### 1. Inspection and maintenance chart:

To enable the use of machine always in its top condition, be sure to conduct maintenance inspection in accordance with the chart below:

#### Machine Inspection:

Item		Hours of Operation
Pre-start up inspection:	Loosened or missing screws	8 Hours (Daily)
	Damage of parts or components	Ditto
	Function of control system components	Ditto
	Leakage in hydraulic system piping	Ditto
Vibrator oil – Check		Every 100 hours
Vibrator oil – Replacement		Every 300 hours
Hydraulic oil – Check		Every 100 hours
Hydraulic oil – Replacement		At first 200 hours; every 1,000 hours thereafter
V-belt (Clutch) – Inspection		Every 200 hours

#### Engine Inspection (See Engine Instruction Manual for detail)

Item	Hours of Operation
Oil and/or fuel leakage	Every 8 hours (Daily)
Tightness of fasteners	Ditto
Engine oil – Check and replenishment	Ditto (Replenish to specified level when insufficient)
Engine oil – Replacement	At first 20 hours; every 100 hour thereafter
Air cleaner – Clean	Every 50 hours

**⚠ NOTE:** Above intervals are for normal operating circumstances. Shorten it or improve the substance of service according to requirement.

**⚠ NOTE:** Fuel piping should be replaced in every 2 years

### 2. Replacing engine oil:

Replace engine oil after first 20 hours and in every 100 hours of operation thereafter. It is easier to drain oil when engine is warm after its operation (For detail, see engine supplier's manual).

### 3. Cleaning the air cleaner:

Air cleaner element should be cleaned, as it becomes dirtier not merely engine starting difficulty, lack of power or operating deficiency will result in but useful life of the engine itself will be shortened (For detail, see engine supplier's manual).

## 4. Checking and replacing V-belt and clutch:

### a. Checking the V-belt (See Fig.33)

In every 200 hours of operation, with the belt cover (upper) removed, check the tension of V-belt. The tension is normal if the bend is about 10mm when the belt is pressed with our finger at midway between the pulleys.

When the belt is slackened, transmission of engine rotation will be deficient, resulting in poor compaction and accelerated wear of the belt.

### b. V-belt replacing procedure:

#### V-belt removal

With upper and lower belt covers removed, engage offset wrench (13mm) to vibrator pulley tightening bolt (lower). Hook a piece of cloth at left side midway of the V-belt and pull it back forcibly while rotating the wrench clockwise until the belt comes off.

#### V-belt reinstallation

Engage the V-belt to vibrator pulley at the bottom and press the V-belt against left side of the upper clutch. Same as in the case of removal, rotate the offset wrench clockwise until the belt is installed.

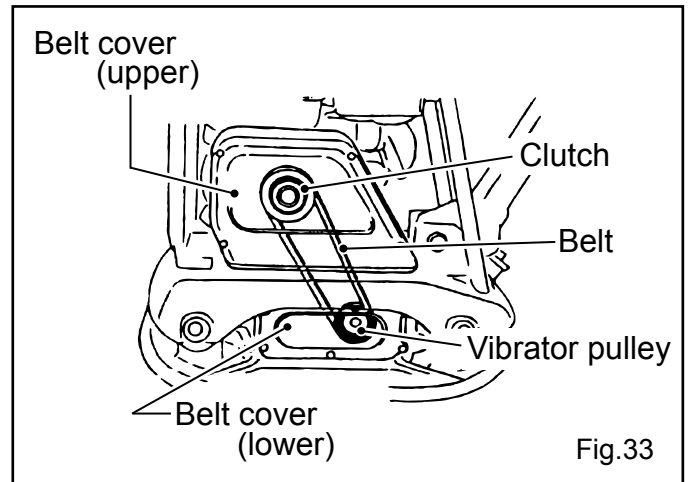

Fig.33

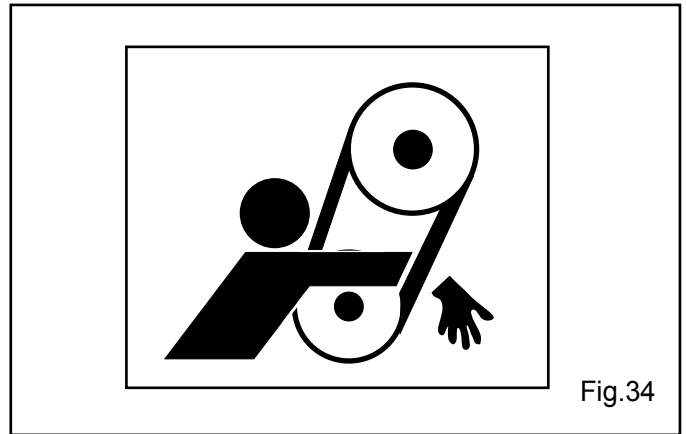

Fig.34

**⚠ NOTE:** There is a risk for injury. Use sufficient care for your hand not to be caught between the belt and clutch. Use glove for protection.

### c. Checking the clutch:

Check the clutch simultaneously when you check V-belt. With the belt cover removed, visually check the outer drum of clutch for seizure, V-groove for wear or damage. Clean the V-groove as necessary. Wear of lining and shoe should be checked through operation.

Worn shoe reduces transmission efficiency of engine rotation, causing a slip to occur.

### d. Replacing the clutch:

- Remove V-belt (See above for the procedure).
- Remove bolt at the engine power output shaft end by giving a shock to a wrench (tap on with hammer) engaged to it and turning it counterclockwise.
- Pull out the clutch by means of pulley puller.
- Reinstall the clutch with above procedure reversed. Turn-in the bolt securely by giving a shock to the

**⚠ NOTE:** If vibration is weakened during operation or vibration does not occur in spite of engine running, conduct the check of V-belt and clutch regardless of maintenance interval of 200 hours.



## 5. Checking the vibrator oil (See Fig.35):

In every 100 hours of operation, position the machine horizontally and remove the vibrator oil level check plug (use 14mm wrench) to see oil is up to the port.

In every 300 hours of operation, change the vibrator oil. Drain oil through level check plug hole with the machine inclined by inserting a sleeper or the like under the opposite side of compaction plate.

\*Lubrication oil to use: Engine oil 10W-30.

Oil Capacities: R60 Series: 0.25 Liter  
100 Series: 0.35 Liter  
150 Series: 0.35 Liter

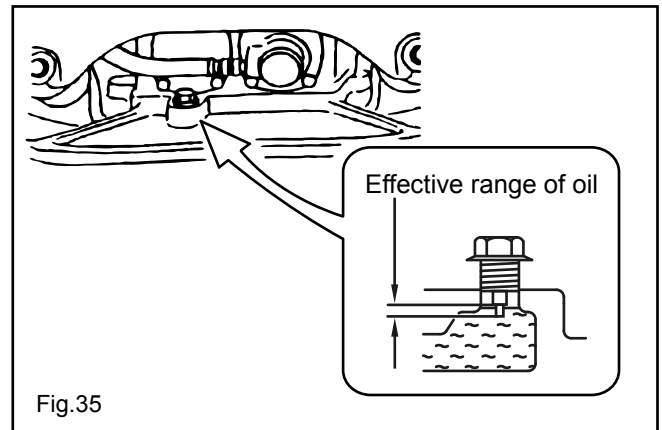

Fig.35

**⚠ NOTE:** To prevent dust from entering, clean the port before proceeding with the vibrator oil check.

**⚠ NOTE:** In case any leakage from vibrator should be detected, check vibrator oil frequently.

## 6. Checking the hydraulic oil (See Fig.36):

a. Check the hydraulic oil in every 100 hours of operation.

With the handle positioned vertically (stowed position), remove breather plug at the top of hydraulic hand pump and check the oil for proper level (To OIL LEVEL mark)

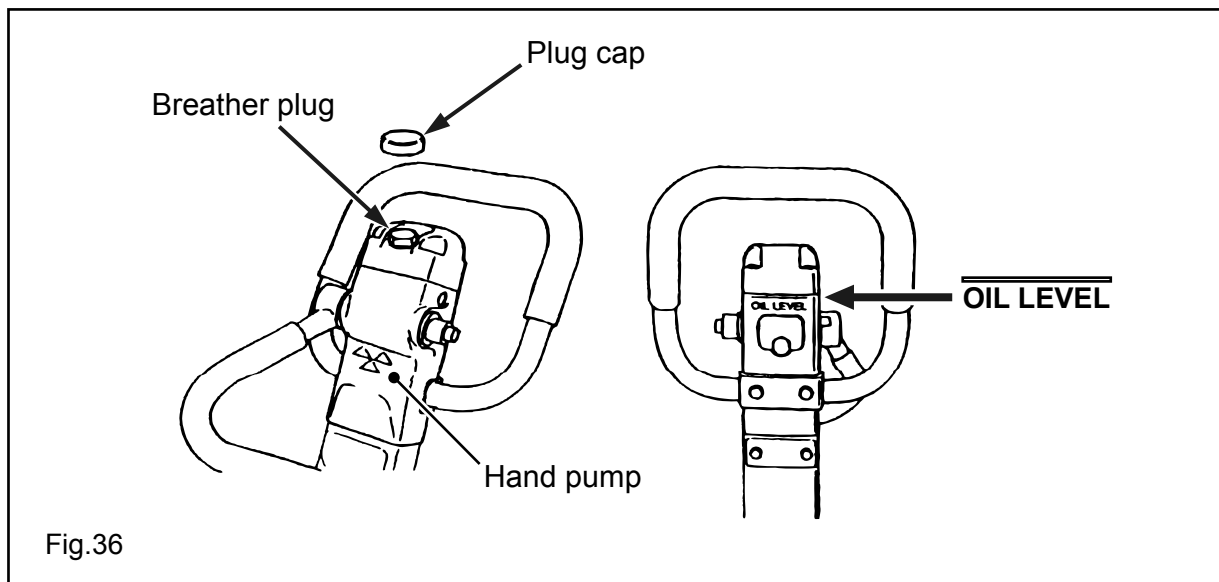

Fig.36

## 7. Replacing the hydraulic oil:

Change the oil at first 200 hours and in every 1,000 hours of operation thereafter.

**⚠ NOTE:** Be careful not to allow any dust to enter the hand pump during the work.

With the plug cap taken off the hand pump, remove

1. breather plug (with 24mm wrench) before disconnecting hydraulic hose which has entered vibrator cylinder at the vibrator side, and with the travel lever placed in forward position, drain the hydraulic oil.

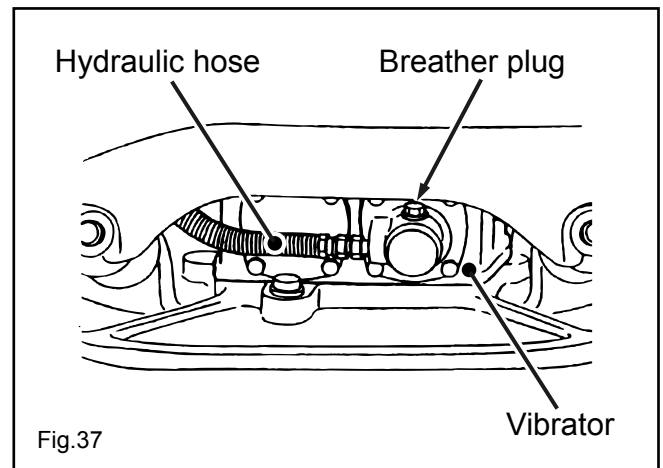

2. After draining hydraulic oil, reinstall the hydraulic hose to vibrator.
3. Feed hydraulic oil through breather plug of the hand pump.

Hydraulic oil capacity:	R-60	Series:	0.26 Liter
	100/150	Series:	0.30 Liter

4. Shortly after removing breather plug at the vibrator cylinder, oil starts to flow out of the plug hole. Wait until aeration disappears before replacing the plug. Tighten it securely. (See Fig.37)
5. Install breather plug to hand pump and fit the plug cap. Breather plug should be reinstalled only after making sure that hydraulic oil in the pump is up to OIL LEVEL.

**⚠ NOTE:** Be sure to fill the hydraulic oil exactly to the OIL LEVEL. Excessive filling causes oil to gush out of the breather.

6. Hydraulic oil to use: Shell Tellus Oil #46 or its equivalent

## 8. Checking the battery:

The battery installed is of maintenance-free type and replenishment with electrolyte is not needed. If voltage drops, replace with new battery because rapid charging is not possible.

### a. Removing the battery:

1. With two M8 nuts removed, take off the battery cover.
2. Disconnect the battery terminals, starting with (-) terminal. For installation, start with (+) terminal and connect (-) terminal lastly.

**⚠ NOTE:** When removing cables, use care not to allow short circuiting between (+) and (-) terminals.

3. Take out the battery from the machine.

### b. Checking and cleaning the battery:

1. Check the battery for crack or any other damage.
2. Check the terminals for decay. If decayed, polish it with wire brush or emery paper, before coating the terminals with grease.
3. Clean the externals of battery.
4. Check and clean the battery stowing space of the machine.

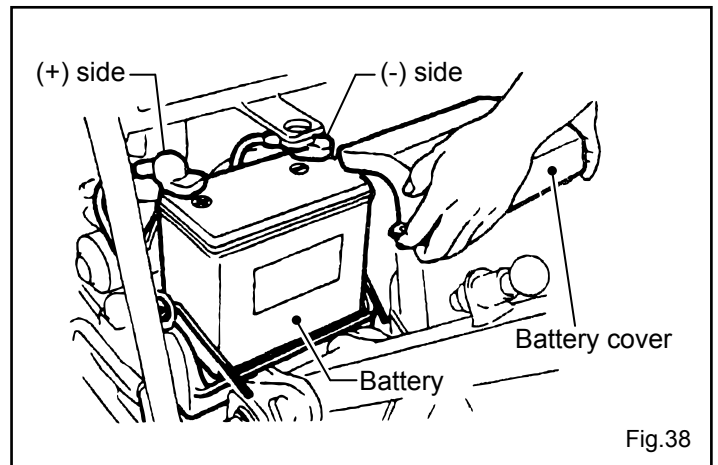

Check vibration isolating mattress as well and replace as necessary.

# 7 TROUBLE SHOOTING

## 1. Gasoline Engine

### (1) Deficient start up

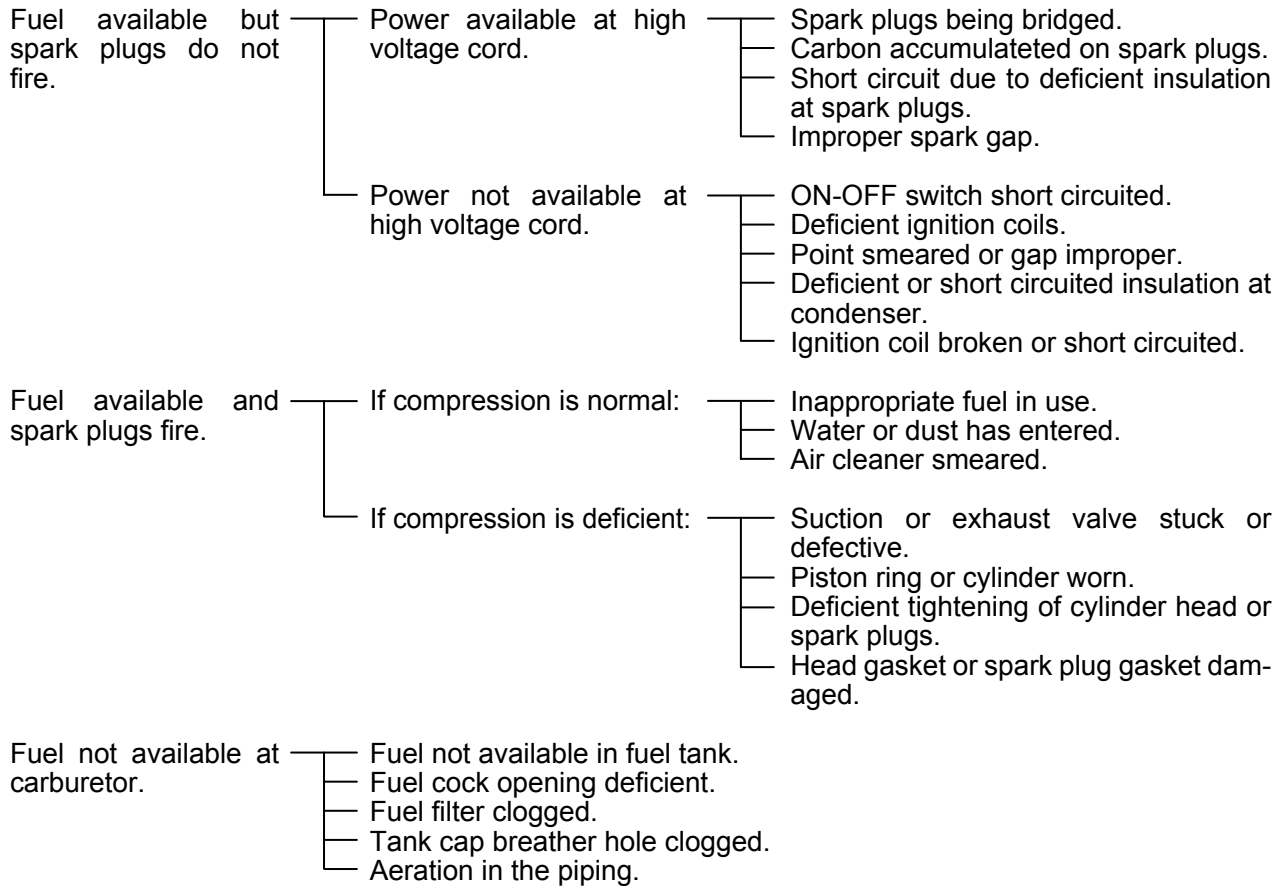

### (2) Operation deficient:

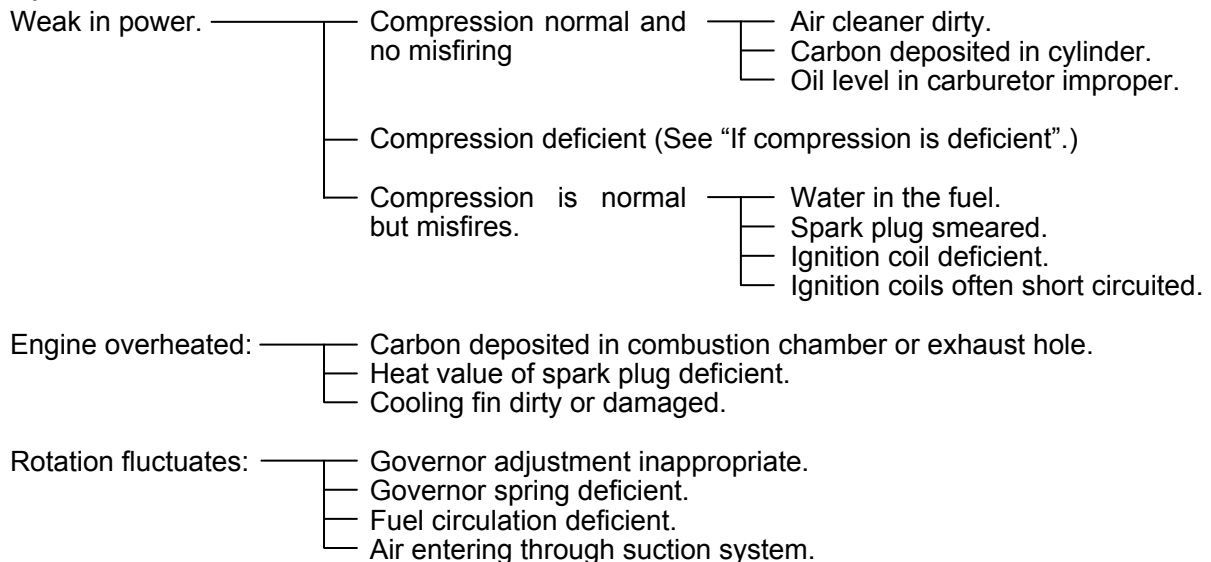

(3) Recoil starter operation deficient: 

- Rotator clogged with dust.
- Spiral spring fatigue.

## 2. DIESEL ENGINE

### (1) Starting deficiency

#### (A) Due to deficient compression:

No compression available. ———— Intake or exhaust valve defective  
Decompression adjustment deficient.

Nearly no or very little Compression available: ———— Valve seat contact deficient.  
Piston ring worn.  
Cylinder worn.  
Mating surface between cylinder and cylinder head deficient.  
Nozzle seat loose.

#### (B) Due to improper fuel injection in combustion chamber:

Very little or no fuel flow: ———— Air breather hole in tank cap clogged.  
Fuel strainer passage clogged or strainer clogged.  
Fuel strainer cock closed.  
Aeration in piping (Particularly occurs when fuel tank is emptied.)

Fuel injection not available in combustion chamber: ———— Injection pump barrel and plunger stuck.  
Nozzle hole clogged.  
Nozzle needle stuck.

Fuel not available in the tank.

Water or dust entered.

#### (C) Does not start even combustion and compression are normal:

Does not reach starting rpm: ———— Improper starting procedure.  
Engine oil viscosity too high or highly contaminated.  
Aeration in piping.

#### (D) Poor Battery

### (2) Insufficient output and deficient operation:

Compression insufficient. ———— See ("Due to deficient compression" above.)

Engine overheated and dark exhaust ———— Dirty cooling fins.  
Water entered fuel filter.  
Carbon deposited in fuel chamber or exhaust hole.  
Smoke set improper.  
Overloading.  
Injection timing inappropriate.  
Nozzle clogged.

RPM fluctuates: ———— Deficient contact between governor and sleeve.  
Deficient governor spring.  
Fly plate and sliding parts worn or deficient in actuation.

Engine speed does not rise: ———— Valve open/close timing inappropriate.  
Exhaust hole or muffler clogged.  
Overloading.

Misfires accompanying white smoke exhaust (unloaded):

- Piston, cylinder and ring worn.
- Nozzle hole clogged.
- Piston ring stuck.
- Piston ring installed upside down.
- Injection timing improper.
- Valve open/close timing improper.
- Injection pump joint loosened.

Fuel consumption high (Dark smoke exhaust.):

- Leakage from fuel passage.
- Air cleaner element clogged.
- Defective fuel due to foreign matter entering.
- Overloading.

Sliding parts worn extremely or piston stuck:

- Improper oil used.
- Oil replacement neglected.
- Air cleaner element broken or its cleaning neglected.

Engine stopped suddenly with abnormal noise: — Piston and rod seizure and damage.

Lubrication oil diluted and increases in volume: — Injection pump plunger barrel worn.

Engine does not stop with fuel supply discontinued (or over runs):

- Excessive oil.
- Governor improperly assembled.
- Injection pump rack disengaged.

### 3. MACHINE ON THE WHOLE

Travel speed slow and vibration weak:

- Engine power output insufficient or rpm setting improper for high speed range.
- Clutch slips.
- V-belt slips.
- Excessive oil in vibrator.
- Internal defect in vibrator.
- Aeration in traveling hydraulic oil.

Travels forward or reverse but direction not selectable:

- Forward/reverse selector component defective.
- Travel lever installation deficient.
- Oil hose broken.
- Aeration in oil of hydraulic system for traveling.
- Improper oil level in hydraulic system (excessive or insufficient).
- Selector valve clogged with dust.
- Piston bearing broken in cylinder, leakage in USH packing, etc.
- Connecting groove between gear pump input shaft and adapter broken or worn.

Does not travel forward nor reverse:

- V-belt disengaged or slipping.
- Clutch slipping.
- Vibrator locked.
- Connecting groove between gear pump input shaft and adapter broken or worn.
- Piston bearing broken in cylinder, leakage in USH packing, etc.

Resistance of travel lever great. — Excessive oil in hydraulic system.

Engine rpm does not rise efficiently: — Isolation rubber damaged or failed.

# 8 WIRING DIAGRAM

## MVH-150DS(DY23)

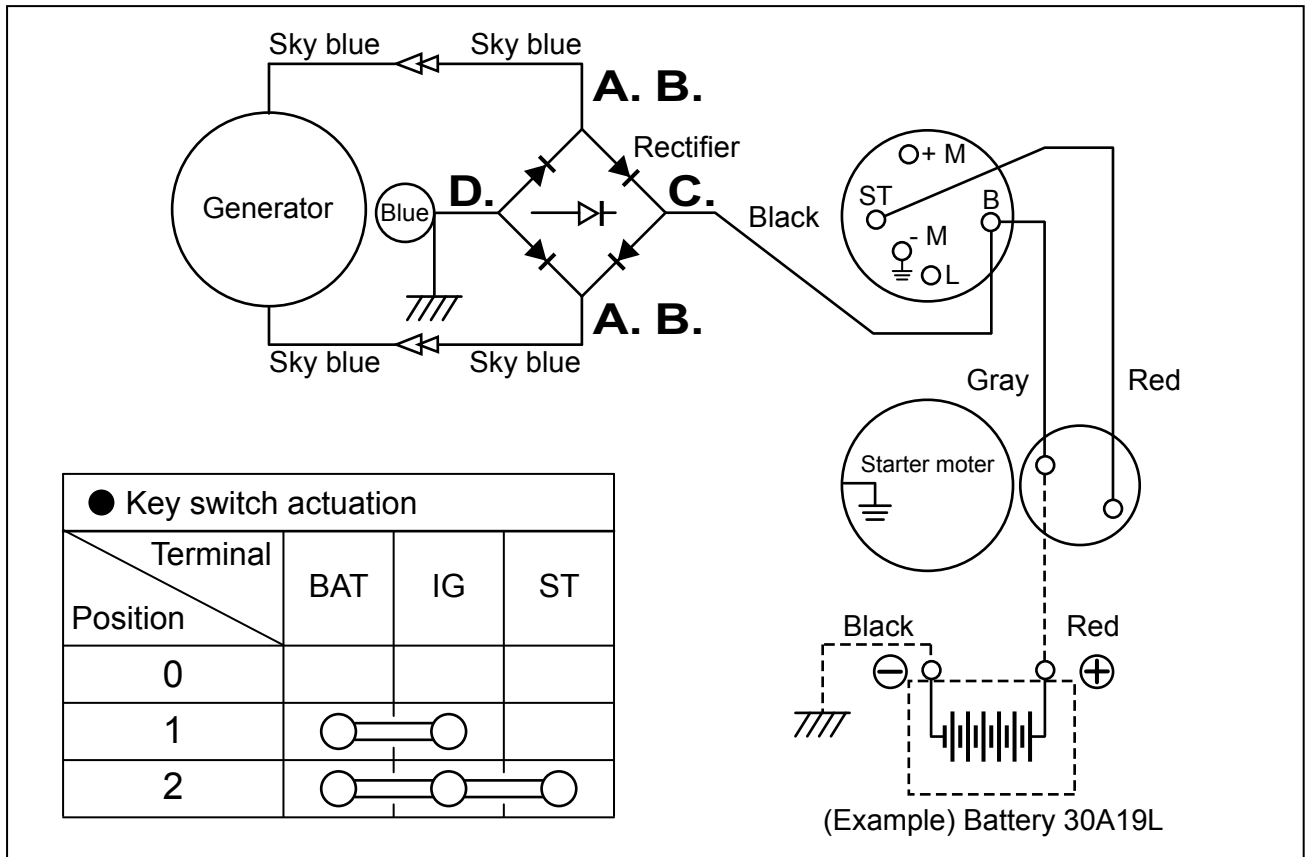

### ● How to check regulator:

Use the tester and the regulator is normal if the result is as follows:

		Connect the red (+) terminal of the tester.			
		A	B	C	D
Connect the black (-) terminal of the tester.	A		Continuity not available	Continuity available	Continuity not available
	B	Continuity not available		Continuity available	Continuity not available
	C	Continuity not available	Continuity not available		Continuity not available
	D	Continuity available	Continuity available	Continuity available	

⚠ **NOTE:** If battery connection should be reversed in terms of (+) and (-), diode will be burnt immediately.

⚠ **NOTE:** For checking, use any commercially available radio tester. Do not use a Mega tester or any other tester that uses large capacity battery as power supply.



**MIKASA SANGYO CO.,LTD.**

HEAD OFFICE  
NO. 4-3. 1-CHOME, SARUGAKU-CHO, CHIYODA-KU  
TOKYO, JAPAN

<http://www.mikosas.com>