

***Mikasa***

***REVERSIBLE COMPACTOR***

**MVH-508**

**PARTS LIST**

**405-07501**

[www.mikasas.com](http://www.mikasas.com)



# PARTS REMARK INDEX

## How to read the marks and remarks used in this parts book.

### Section 1 : Explanation of Code Use In “MRK” Column

OO : Interchangeable between the new part and the old one.

XX : Not Interchangeable between new and old.

OX : New part is usable for the old machine but the old part is not usable for the new machine.

XO : The old part is usable for the new machine but the new part is not usable for the old machine.

Note : In case of the lack of interchangeability between the new part and old part, a new part may be used by replacing all other parts found in the assembly. In this case, refer to section 2 for instruction on identifying other parts involved in a new assembly.

AD : Newly established(added)

DC : Suspended(discontinued)

NC : Part number changed

QC : Quantity used has been changed

NS : Not supplied individually but supplied in an assembly or a group.

AS : Special part designed to allow interchangeability between new and old part.

CR : Correction

### Section 2 : Items Found In “Remark” Column

Serial Numbers — Where indicated, this indicates a serial number range (inclusive) where a particular part is used.

Model Number — Where indicated, this shows that the corresponding part is utilized only with this specific model number or model number variant.

# or \* : All parts with the same number following # or \* belong to the same assembly. this part cannot be interchanged individually with any other assemblies to replace an old part (indicated by #), with a new part(indicated by \*), then all other parts of that assembly must be replaced with new ones.

Note : If more than one of the same reference number is listed, the last one listed indicates newest(or latest)part available.

### Section 3: Example

REF NO.	PART NO.	PART NAME	QTY	MRK	REMARKS
457(1)	5122-09230	Hinge Metal, Upper/24g	1		-1070 #3 (5)
457(2)	5072-09420	Hinge Metal, Upper M16	1	OX(3)	U1071-(6) * 3(7)

(1) Old part

(2) New part

(3) New part usable with old machine, but old part not usable with new machine (reference section 1).

(4) Old part number is used through this machine serial number.

(5) Old part, used in an assembly with other parts marked with #3. To use this part on a new machine, all other parts in this assembly must be replaced with old ones.

(6) New part put into use starting with this serial number and is still current.

(7) New part used in an assembly with other parts marked \* 3, to use this part as a replacement for an old part, all other \* 3 marked parts must be changed at the same time.

### Section 4: Items Found In “MK2” Column

(only for suspended products)

! OO (“OO” is shown in figure) : The part shown in lower line is supplied.

! SD : Not available due to termination of production.

! NS : Not supplied individually, but supplied in an assembly or a group.

! PD : Supplied as unit product.

SS : Not available after stock run out.

(The contents of this parts catalog are subject to change without notice.)

# MVH-508

VIBRATING PLATE

4TV0

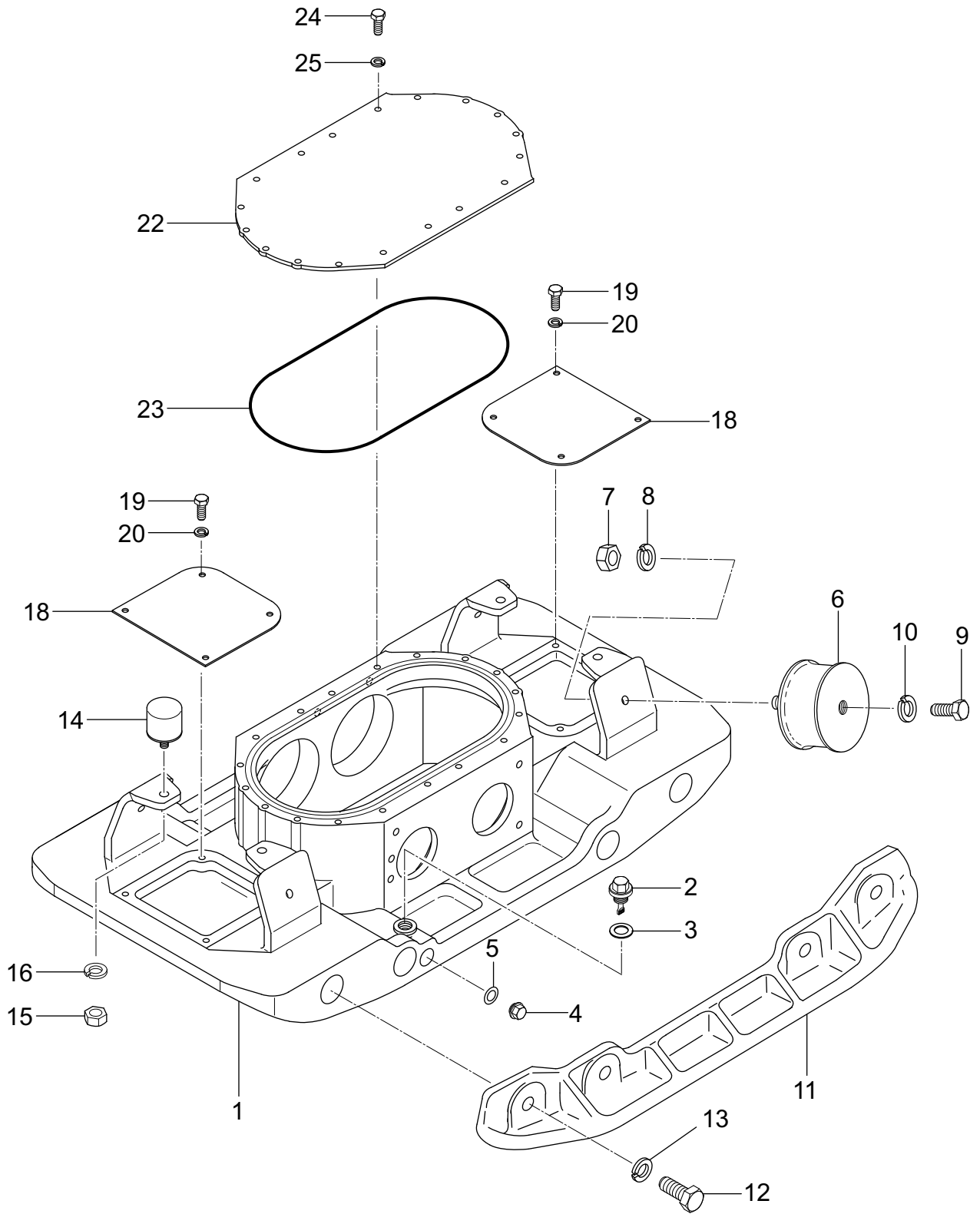



# MVH-508

4TWO

VIBRATOR (With compaction sensor)

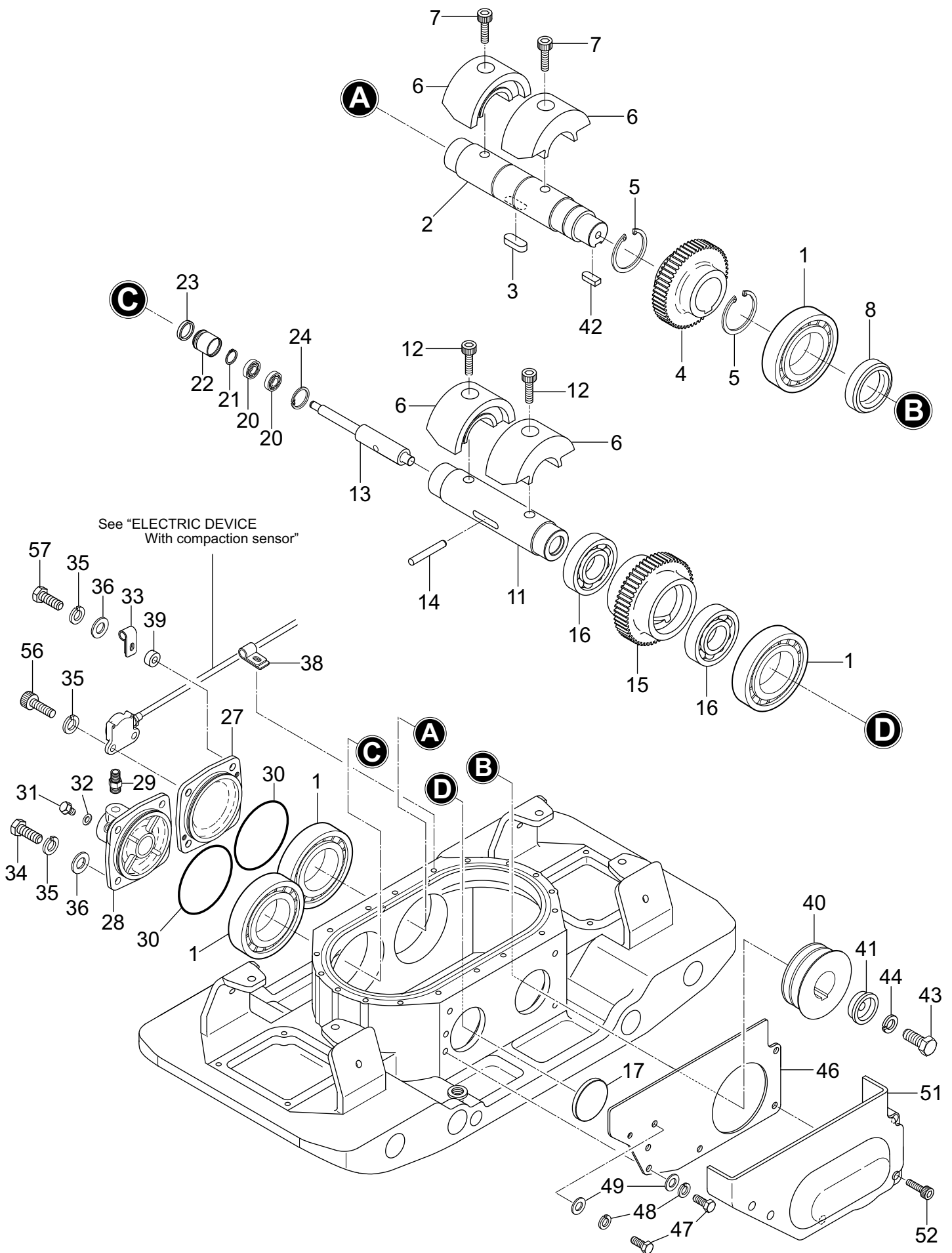

# MVH-508

2014/4/25

## VIBRATOR (With compaction sensor)

\*\* 4TW \*\*

REF NO.	PART NO.	PART NAME	Q' TY	MRK	MK2	REMARKS
1	0479-20120	ROLLER BEARING NJ310EMC4	4			
2	4572-12410	ROTARY SHAFT, DRIVE/MVH400	1			
3	9514-05370	KEY 15X10X39 RR	1			
4	4563-27150	GEAR, DRIVE /MVH-302	1			
5	0802-00550	STOP RING S-55	2			
6	4693-52310	ECCENTRIC ROTATOR /MVH508	4			
7	0091-20301	SOCKET HEAD BOLT 16X40T	2			
8	0601-05030	OIL SEAL SB-50729	1			
11	4563-37670	ROTARY SHAFT, DRIVEN/304B	1		SX	
12	0091-20302	SOCKET HEAD BOLT 16X30T	2		SX	
13	4563-37380	PISTON ROD /MVH-304B	1			
14	4560-10010	KNOCK PIN 10X70 /MVH-302	1		SX	
15	4673-51910	GEAR (DRIVEN) /MVH-308	1			
16	0400-06911	BEARING 6911C3	2			
17	9530-10030	SEAL CAP/SC72-8N	1			
20	0425-06000	BEARING 6000ZZSG	2			
21	0802-00100	STOP RING S-10	1			
22	4554-35051	PISTON, 22. 4D /MVH-200	1		SX	
23	4550-10070	PACKING USH-22. 4X30X5	1			
24	0801-00260	STOP RING R-26	1			
27	4673-52540	BEARING COVER /MVH-308	1			
28	4672-19070	CYLINDER (R) /MVH-308	1			
29	9540-10020	CONNECTOR PT, PF1/4	1			
30	0501-01050	O-RING G-105	2			
31	0017-20812	FLANGEBOLT8X12	1			
32	9534-04600	COPPER PACKING 8. 2X16X1. 6	1		SX	
33	9594-08880	CLIP 15(M10) /MVH-308	1			
34	0012-21025	BOLT 10X25 T	5			
35	0302-10250	SW M10	8			
36	0311-10160	PW M10	6			
38	9594-08920	CLIP 8(M8) /MVH-308	1			
39	7404-26290	SPACER 10. 5X22X10T	1			
40	4693-52320	PULLEY / MVH-506	1			
41	4564-37920	WASHER, PULLEY /MVH-302	1			
42	9514-04970	KEY 12X8X30 R	1			
43	0012-21235	BOLT 12X35 T	1			
44	0302-12300	SW M12	1			
46	4673-51920	CUIDE, BELT COVER/MVH-308	1			
47	0012-20820	BOLT 8X20 T	2			
48	0302-08200	SW M8	2			
49	0311-08160	PW M8	2			
51	4692-19030	BELT COVER, LOWER/MVH-508	1			
52	0015-20860	SOCKET HEAD BOLT 8X100 T	5			
56	0015-21030	SOCKET HEAD BOLT 10X30 T	2			
57	0012-21035	BOLT 10X35 T	1			

# MVH-508

4TX0

VIBRATOR (Without compaction sensor)

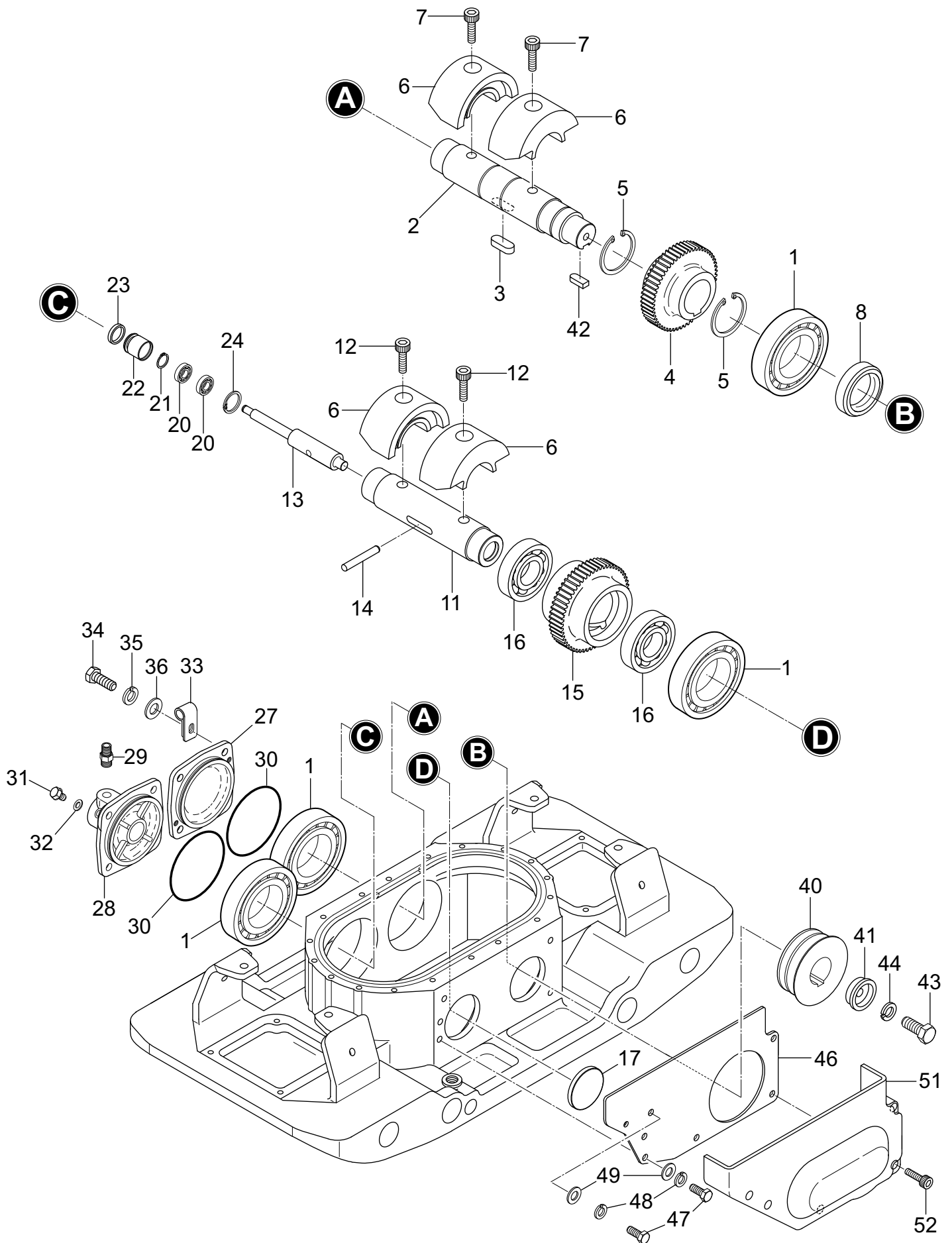



**MVH-508**

2014/4/25

**VIBRATOR (Without compaction sensor)****\*\* 4TX \*\***

REF NO.	PART NO.	PART NAME	Q' TY	MRK	MK2	REMARKS
1	0479-20120	ROLLER BEARING NJ310EMC4	4			
2	4572-12410	ROTARY SHAFT, DRIVE/MVH400	1			
3	9514-05370	KEY 15X10X39 RR	1			
4	4563-27150	GEAR, DRIVE /MVH-302	1			
5	0802-00550	STOP RING S-55	2			
6	4693-52310	ECCENTRIC ROTATOR /MVH508	4			
7	0091-20301	SOCKET HEAD BOLT 16X40T	2			
8	0601-05030	OIL SEAL SB-50729	1			
11	4563-37670	ROTARY SHAFT, DRIVEN/304B	1		SX	
12	0091-20302	SOCKET HEAD BOLT 16X30T	2		SX	
13	4563-37380	PISTON ROD /MVH-304B	1			
14	4560-10010	KNOCK PIN 10X70 /MVH-302	1		SX	
15	4673-51910	GEAR (DRIVEN) /MVH-308	1			
16	0400-06911	BEARING 6911C3	2			
17	9530-10030	SEAL CAP/SC72-8N	1			
20	0425-06000	BEARING 6000ZZSG	2			
21	0802-00100	STOP RING S-10	1			
22	4554-35051	PISTON, 22.4D /MVH-200	1		SX	
23	4550-10070	PACKING USH-22.4X30X5	1			
24	0801-00260	STOP RING R-26	1			
27	4673-52540	BEARING COVER /MVH-308	1			
28	4672-19070	CYLINDER (R) /MVH-308	1			
29	9540-10020	CONNECTOR PT, PF1/4	1			
30	0501-01050	O-RING G-105	2			
31	0017-20812	FLANGEBOLT8X12	1			
32	9534-04600	COPPER PACKING 8.2X16X1.6	1		SX	
33	9594-08880	CLIP 15(M10) /MVH-308	1			
34	0012-21025	BOLT 10X25 T	8			
35	0302-10250	SW M10	8			
36	0311-10160	PW M10	8			
40	4693-52320	PULLEY / MVH-506	1			
41	4564-37920	WASHER, PULLEY /MVH-302	1			
42	9514-04970	KEY 12X8X30 R	1			
43	0012-21235	BOLT 12X35 T	1			
44	0302-12300	SW M12	1			
46	4673-51920	GUIDE, BELT COVER/MVH-308	1			
47	0012-20820	BOLT 8X20 T	2			
48	0302-08200	SW M8	2			
49	0311-08160	PW M8	2			
51	4692-19030	BELT COVER, LOWER/MVH-508	1			
52	0015-20860	SOCKET HEAD BOLT 8X100 T	5			

# MVH-508

## BASE AND ENGINE

4UA0

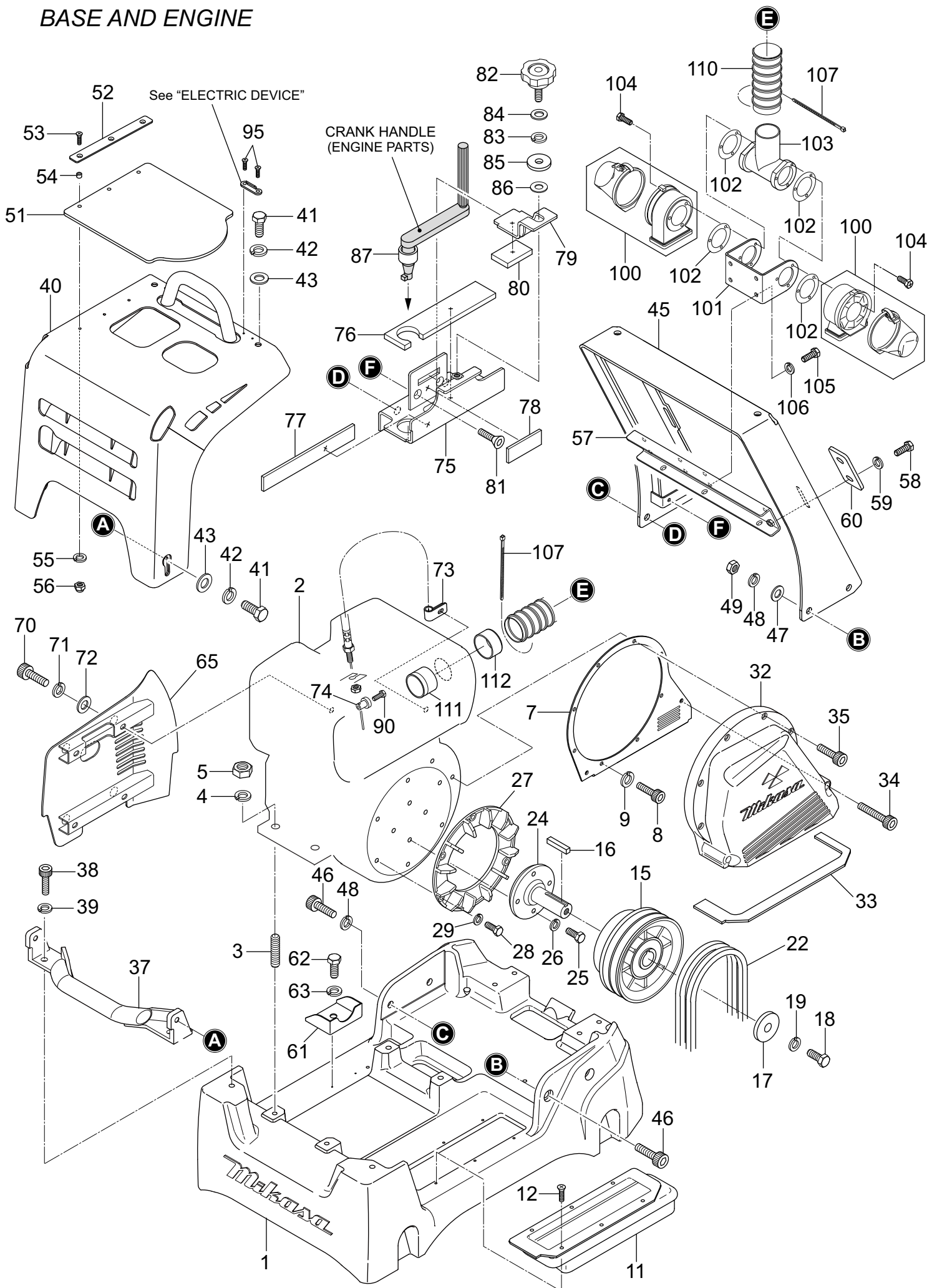

**MVH-508**

2014/4/25

**BASE AND ENGINE****\*\* 4UA \*\***

REF NO.	PART NO.	PART NAME	Q' TY	MRK	MK2	REMARKS
1	4691-21280	BASE /1D81 /MVH-508	1			
2	9184-01200	ENGINE AY/1D81/EPA4/508Z	1			
3	0091-20205	STUD BOLT 12X25 T	4			
4	0302-12300	SW M12	4			
5	0203-12100	NUT M12	4			
7	4693-52260	BELT COVER, IN /MVH-508DSZ	1			
8	0015-21020	SOCKET HEAD BOLT 10X20 T	3			
9	0302-10250	SW M10	3			
11	4692-18980	DUST COVER /MVH-508	1			
12	0920-06010	FLAT HEAD SCREW 6X10	6			
15	4693-52390	CLUTCH AY /MVH-508	1			
16	9510-10130	KEY 7X7X49	1			
17	9524-01390	WASHER 11X40X6	1			
18	0012-21025	BOLT 10X25 T	1			
19	0302-10250	SW M10	1			
22	0702-00483	V-BELT HDPF-5480	2			
24	4573-39571	STUB SHAFT(1D-81)FAN/502B	1			
25	0012-20830	BOLT 8X30 T	4			
26	0302-08200	SW M8	4			
27	4573-36380	FAN /MVH-502	1			
28	0012-20820	BOLT 8X20 T	6			
29	0302-08200	SW M8	6			
32	4692-18990	BELT COVER (OUT)/MVH-508	1			
33	4693-52270	DUST SPONGE(OUT)/MVH-508	1			
34	0015-21058	SOCKET HEAD BOLT 10X90 T	2			
35	0015-21045	SOCKET HEAD BOLT 10X45 T	5			
37	4693-52280	FRONT BUNPER /MVH-508	1			
38	0015-21435	SOCKET HEAD BOLT 14X35 T	2			
39	0302-14350	SW M14	2			
40	4691-21290	FRONT COVER, 1D81/MVH-508	1			
41	0012-21435	BOLT 14X35 T	4			
42	0302-14350	SW M14	4			
43	0311-14260	PW M14	4			
45	4692-19330	CENTER COVER/MVH-508	1			
46	0015-21440	SOCKET HEAD BOLT 14X40 T	4			
47	0311-14260	PW M14	2			
48	0302-14350	SW M14	4			
49	0203-14110	NUT M14	2			
51	4684-66890	RUBBER COVER, UPPER/408	1			
52	4674-66760	STOPPER, COVER/MVH-308Z, Y	1			
53	0091-20424	SOCKET HEAD BOLT 6X25T	3			
54	6174-65130	COLLAR 6.2X7.8X4.5	3			
55	0302-06150	SW M6	3			
56	0227-10607	NYLON NUT M6	3			
57	4693-52890	CLEANER STAY /MVH-508	1			
58	0012-20825	BOLT 8X25 T	4			
59	0302-08200	SW M8	4			
60	4674-67580	PLATE, CLEANER STAY/1B30	2			
61	4694-67000	GUIDE, DRAIN /MVH-508	1			
62	0012-20815	BOLT 8X15 T	1			
63	0302-08200	SW M8	1			
65	4692-19010	SIDE COVER /MVH-508	1			
70	0015-21251	SOCKET HEAD BOLT 12X55 T	4			
71	0302-12300	SW M12	4			
72	0311-12230	PW M12	4			
73	206-75501-01	CLAMP COMPL	1			
74	DH5-06420-00	CLAMP /1D81	1			
75	4692-19120	HOLDER, CRANK HANDLE/508	1			
76	4694-67320	PULYURETHANE SEAT 222X50	1			
77	4694-67310	PULYURETHANE SEAT 220X30	1			

# MVH-508

## BASE AND ENGINE

4UA0

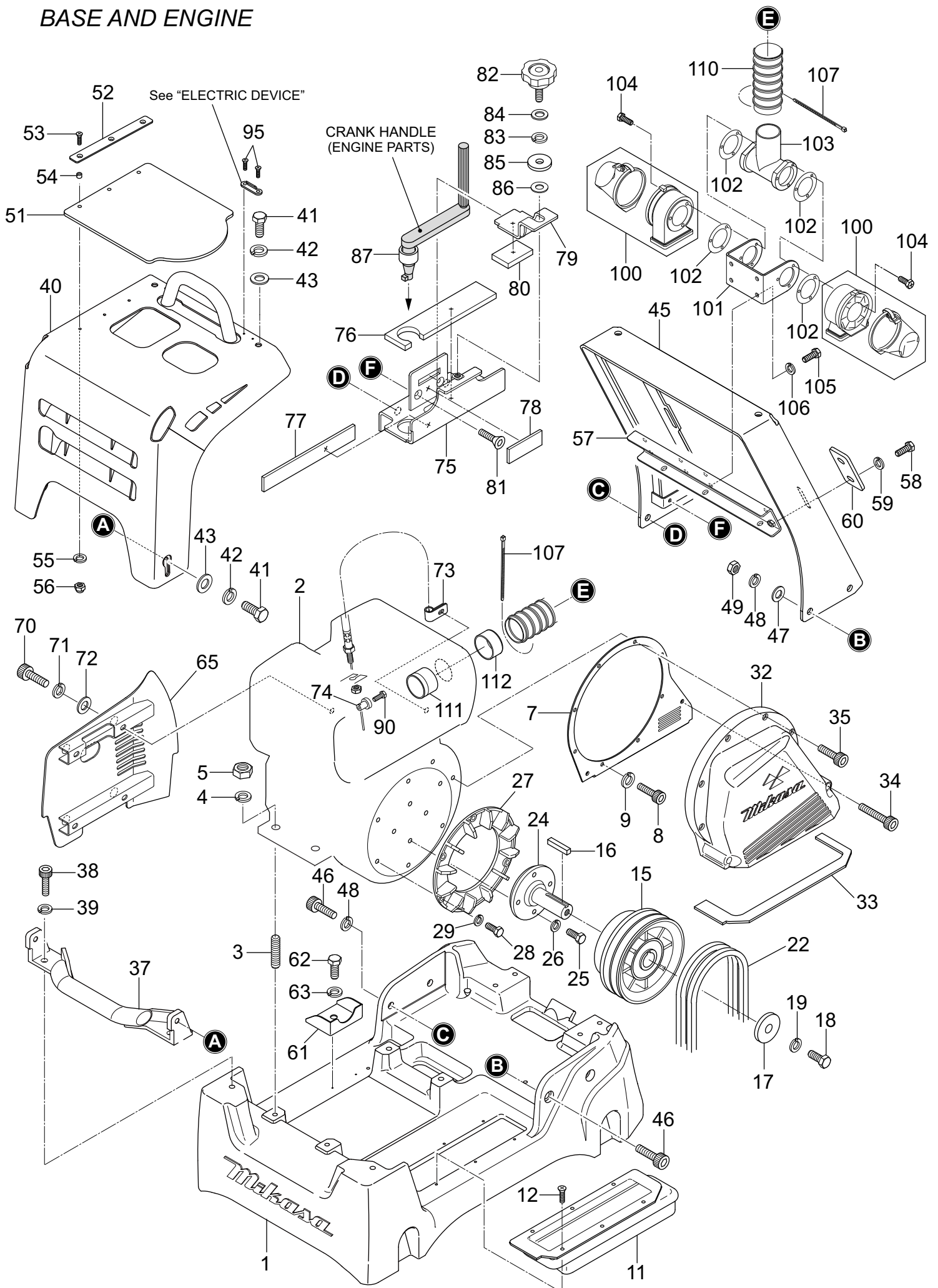



# MVH-508

ELECTRIC DEVICE : With compaction sensor

# 4UB0

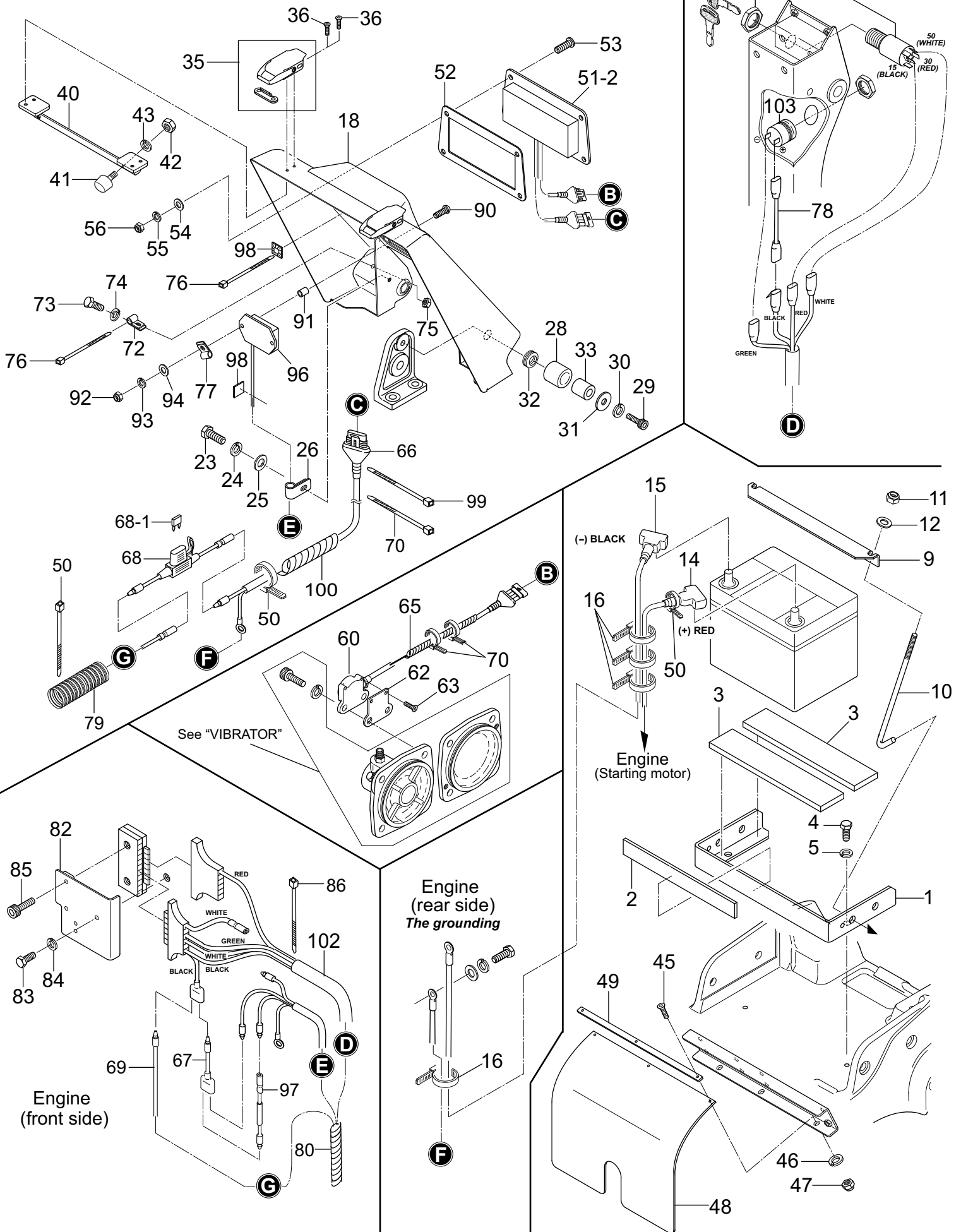

**MVH-508**

2014/4/25

**ELECTRIC DEVICE : With compaction sensor****\*\* 4UB \*\***

REF NO.	PART NO.	PART NAME	Q' TY	MRK	MK2	REMARKS
1	4672-18920	BATTERY HOLDER /MVH-308	1			
2	4564-47590	RUBBER PLATE (E) 28X240X5	1			
3	4564-47600	RUBBER PLATE 50X240X10	2			
4	0012-21020	BOLT 10X20 T	2			
5	0302-10250	SW M10	2			
9	4643-43740	HOLDER, BATTERY / MVH-306	1			
10	4694-67170	BOLT, BATTERY /MVH-508	2			
11	0227-10809	NYLON NUT M8	2			
12	0311-08160	PW M8	2			
14	9553-01030	BATTERY CABLE(+) 1050L	1			
15	9553-01040	BATTERY CABLE(-) 450L	1			
16	5060-10070	CLAMP TC-150	4			
18	4691-21300	REAR COVER /MVH-508D	1			
23	0012-20820	BOLT 8X20 T	1			
24	0302-08200	SW M8	1			
25	0311-08160	PW M8	1			
26	9594-08920	CLIP 8(M8) /MVH-308	1			
28	4044-33430	RUBBER 20X32X28.5/52H	2			
29	0015-21051	SOCKET HEAD BOLT 10X55 T	2			
30	0302-10250	SW M10	2			
31	9524-03450	WASHER 11X35X4.5	2			
32	4674-67250	RUBBER WASHER 20X35X3	2			
33	4174-54420	COLLAR 10.5-20-37.5L	2			
35	4694-67470	CATCH CLIP /MVH-508	2			
36	0091-20421	SOCKET HEAD BOLT 5X15T	4			
40	4693-52340	BRACKET, STOPPER /MVH-508	1			
41	9390-10360	STOPPER RUBBER 30X20H-70	2			
42	0203-08060	NUT M8	2			
43	0302-08200	SW M8	2			
45	0012-20520	BOLT 5X20 T	3		SX	
46	0302-05130	SW M5	3			
47	0227-10506	NYLON NUT M5	3			
48	4674-66930	RUBBER PLATE, BATTERY/308D	1			
49	4674-66920	STOPPER, RUB-PLATE/MVH-308	1			
50	4540-10020	CLAMP TC-100	7			
51	4693-10010	SENSOR PANEL /MVH-508	1			
52	4643-50510	PACKING, SENSOR	1			
53	0091-10062	SOCKET HEAD SCREW 6X20	4			
54	0311-06100	PW M6	4			
55	0302-06150	SW M6	4			
56	0227-10607	NYLON NUT M6	4			
60	4673-52040	ACCELERATION SENSOR AY	1			
62	4644-64350	SENSOR HOLDER COVER/306	1			
63	0091-20420	SOCKET HEAD BOLT 5X10T	2			
65	9590-21812	SPIRAL TUBE 6D-800L	1			
66	4673-52480	HARNESS, SENSOR /MVH-308	1			
67	5154-50380	WIRE HARNESS /MRH-600, 700	1		SX	
68	4673-52850	FUSE HOLDER, SENSOR/DSCPAS	1			
68 -1	4670-10010	FUSE (2A-SMALL) /MVH-308	1			
69	9554-08440	LEAD CORD/500L	1			
70	5060-10070	CLAMP TC-150	9			
72	9594-08920	CLIP 8(M8) /MVH-308	1			ONLY COMPAS
73	0012-20820	BOLT 8X20 T	1			ONLY COMPAS
74	0302-08200	SW M8	1			ONLY COMPAS
75	0203-08060	NUT M8	1			ONLY COMPAS
76	5060-10070	CLAMP TC-150	1			ONLY COMPAS
77	206-75501-01	CLAMP COMPL	1			ONLY COMPAS
78	4654-59680	RELAY CABLE/BUZZER	1			
79	9590-26022	CORRUGATE TUBE 600L/308	1			
80	9590-20014	SPIRAL TUBE KEP-12-500L	1			



# MVH-508

ELECTRIC DEVICE : With compaction sensor

# 4UB0

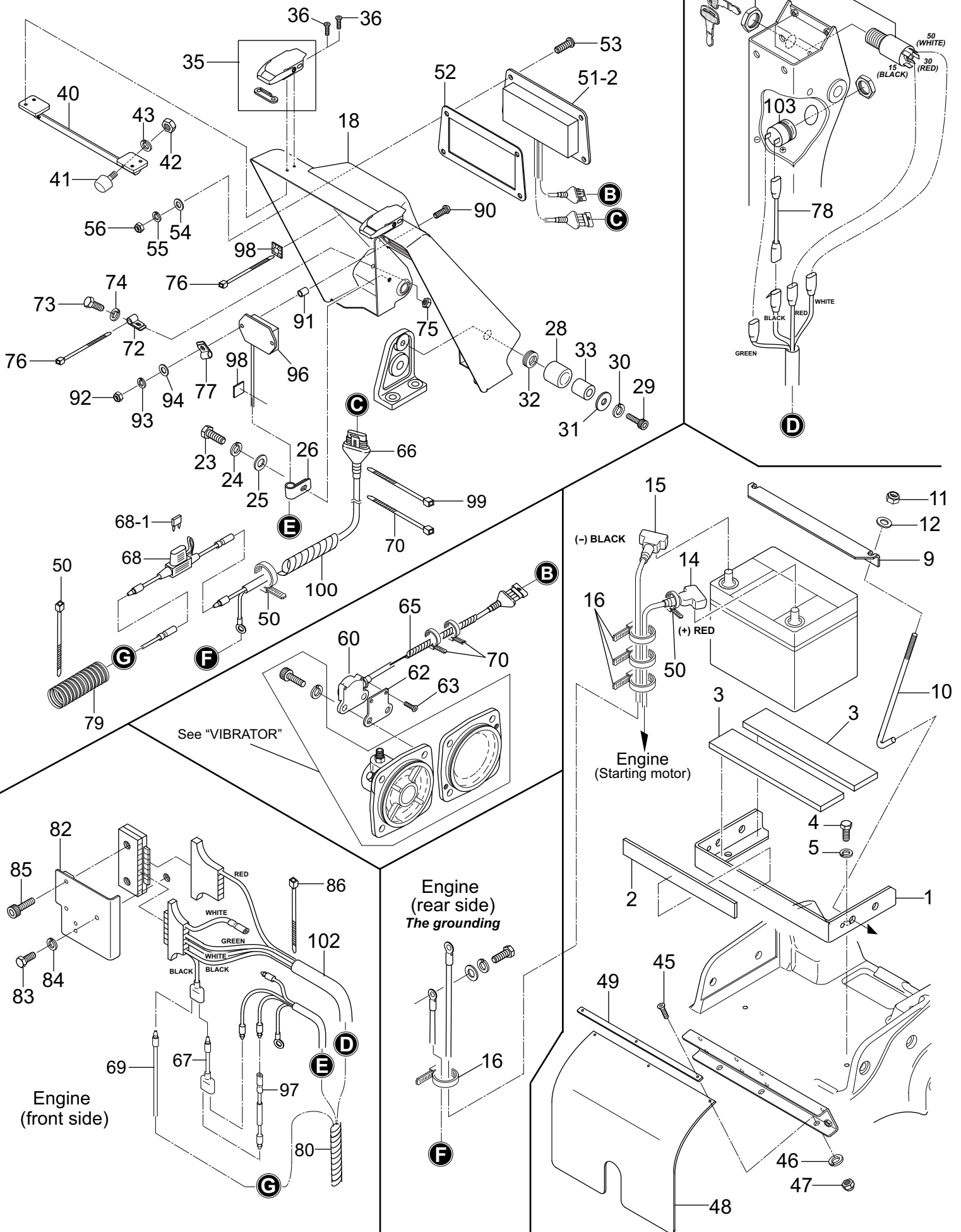





# MVH-508

ELECTRIC DEVICE : Without compaction sensor

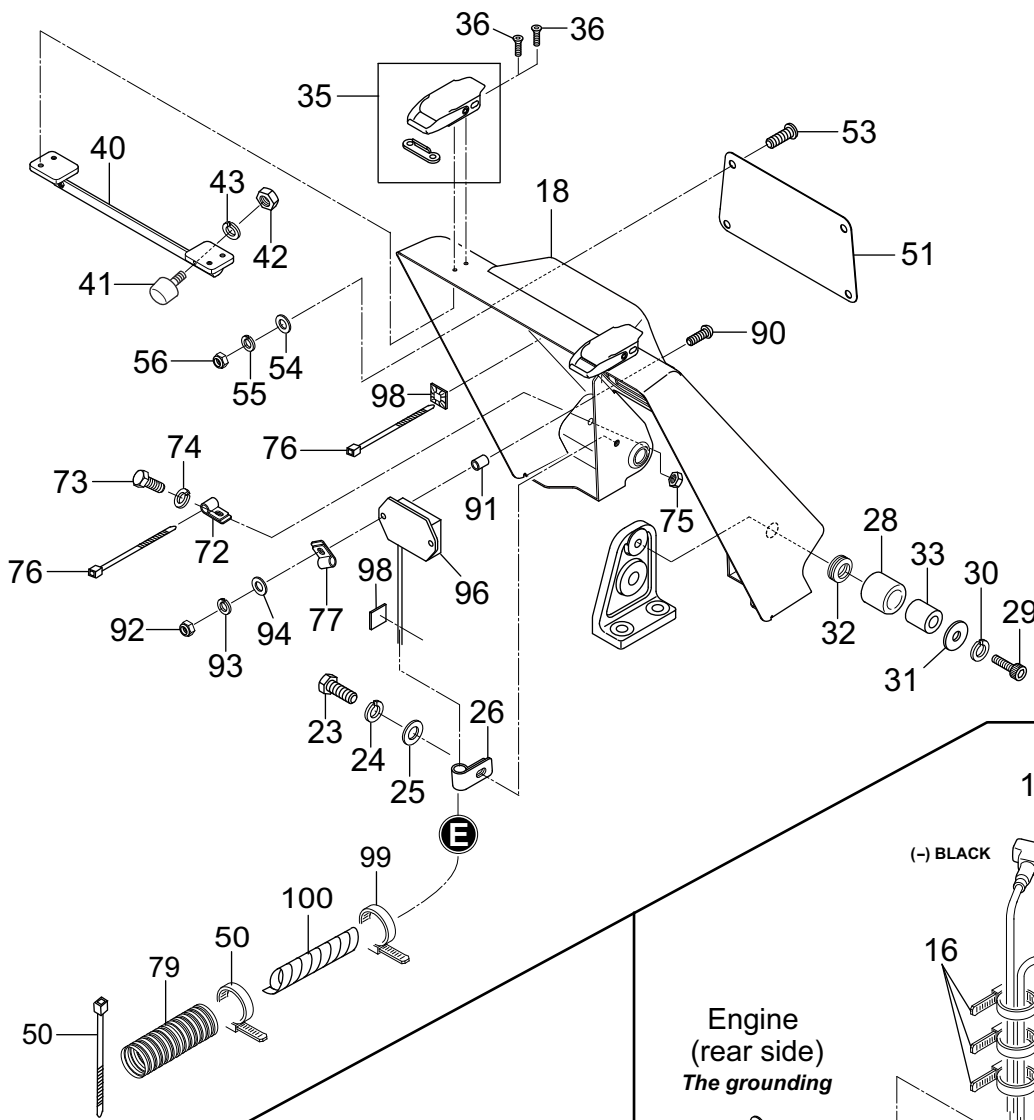

Engine  
(front side)

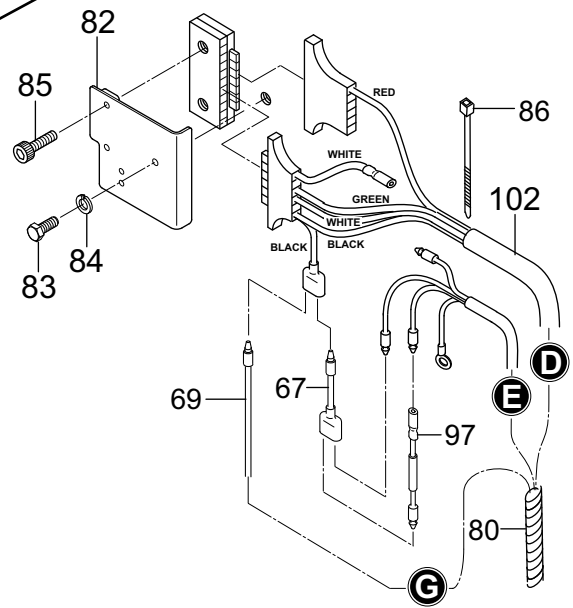

Engine  
(rear side)  
The grounding

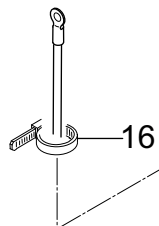

Engine  
(Starting motor)

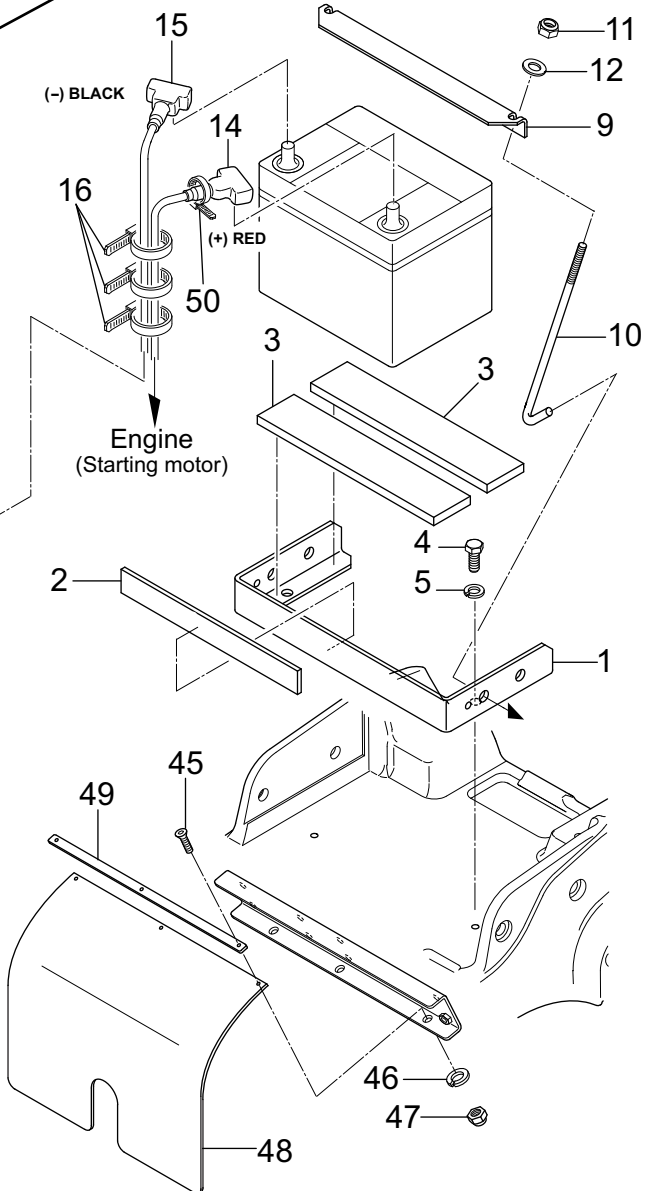

# 4UV0

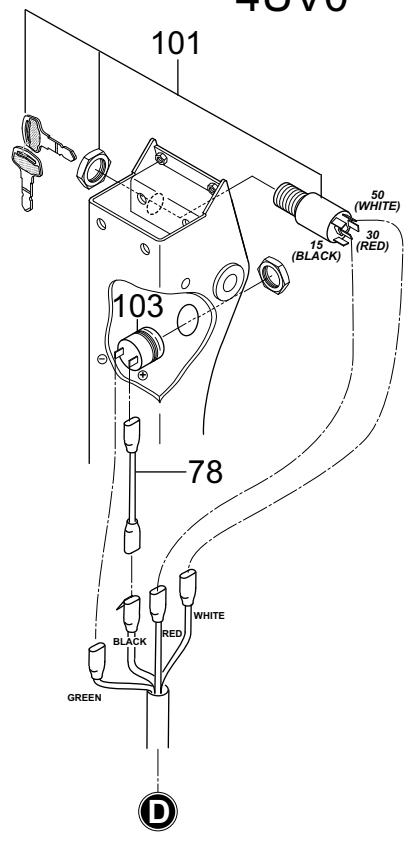

**MVH-508**

2014/4/25

**ELECTRIC DEVICE : Without compaction sensor****\*\* 4UV \*\***

REF NO.	PART NO.	PART NAME	Q' TY	MRK	MK2	REMARKS
1	4672-18920	BATTERY HOLDER /MVH-308	1			
2	4564-47590	RUBBER PLATE (E) 28X240X5	1			
3	4564-47600	RUBBER PLATE 50X240X10	2			
4	0012-21020	BOLT 10X20 T	2			
5	0302-10250	SW M10	2			
9	4643-43740	HOLDER, BATTERY / MVH-306	1			
10	4694-67170	BOLT, BATTERY /MVH-508	2			
11	0227-10809	NYLON NUT M8	2			
12	0311-08160	PW M8	2			
14	9553-01030	BATTERY CABLE(+) 1050L	1			
15	9553-01040	BATTERY CABLE(-) 450L	1			
16	5060-10070	CLAMP TC-150	4			
18	4691-21300	REAR COVER /MVH-508D	1			
23	0012-20820	BOLT 8X20 T	1			
24	0302-08200	SW M8	1			
25	0311-08160	PW M8	1			
26	9594-08920	CLIP 8(M8) /MVH-308	1			
28	4044-33430	RUBBER 20X32X28.5/52H	2			
29	0015-21051	SOCKET HEAD BOLT 10X55 T	2			
30	0302-10250	SW M10	2			
31	9524-03450	WASHER 11X35X4.5	2			
32	4674-67250	RUBBER WASHER 20X35X3	2			
33	4174-54420	COLLAR 10.5-20-37.5L	2			
35	4694-67470	CATCH CLIP /MVH-508	2			
36	0091-20421	SOCKET HEAD BOLT 5X15T	4			
40	4693-52340	BRACKET, STOPPER /MVH-508	1			
41	9390-10360	STOPPER RUBBER 30X20H-70	2			
42	0203-08060	NUT M8	2			
43	0302-08200	SW M8	2			
45	0012-20520	BOLT 5X20	3			
46	0302-05130	SW M5	3			
47	0227-10506	NYLON NUT M5	3			
48	4674-66930	RUBBER PLATE, BATTERY/308D	1			
49	4674-66920	STOPPER, RUB-PLATE/MVH-308	1			
50	4540-10020	CLAMP TC-100	7			
51	4673-52050	PANEL, REAR COVER/MVH-308	1			
53	0091-10062	SOCKET HEAD SCREW 6X20	4			
54	0311-06100	PW M6	4			
55	0302-06150	SW M6	4			
56	0227-10607	NYLON NUT M6	4			
67	5154-50380	WIRE HARNESS /MRH-600, 700	1		SX	
72	9594-08920	CLIP 8(M8) /MVH-308	1			
73	0012-20820	BOLT 8X20 T	1			
74	0302-08200	SW M8	1			
75	0203-08060	NUT M8	1			
76	5060-10070	CLAMP TC-150	1			
77	206-75501-01	CLAMP COMPL	1			
78	4654-59680	RELAY CABLE/BUZZER	1			
79	9590-26021	CORRUGATE TUBE 400L/508	1			
80	9590-20014	SPIRAL TUBE KEP-12-500L	1			
82	4693-52400	PANEL, WITH BUZZER/MVH508	1			
83	0012-20635	BOLT 6X35 T	1			
84	0302-06150	SW M6	1			
85	0015-20530	SOCKET HEAD BOLT 5X30 T	2			
86	5060-10070	CLAMP TC-150	1			
90	0091-10072	PAN HEAD SCREW 5X35	2			
91	9524-07930	COLLAR 6X10X13.5	2			
92	0227-10506	NYLON NUT M5	2			
93	0302-05130	SW M5	2			
94	0311-05080	PW M5	2			

# MVH-508

ELECTRIC DEVICE : Without compaction sensor

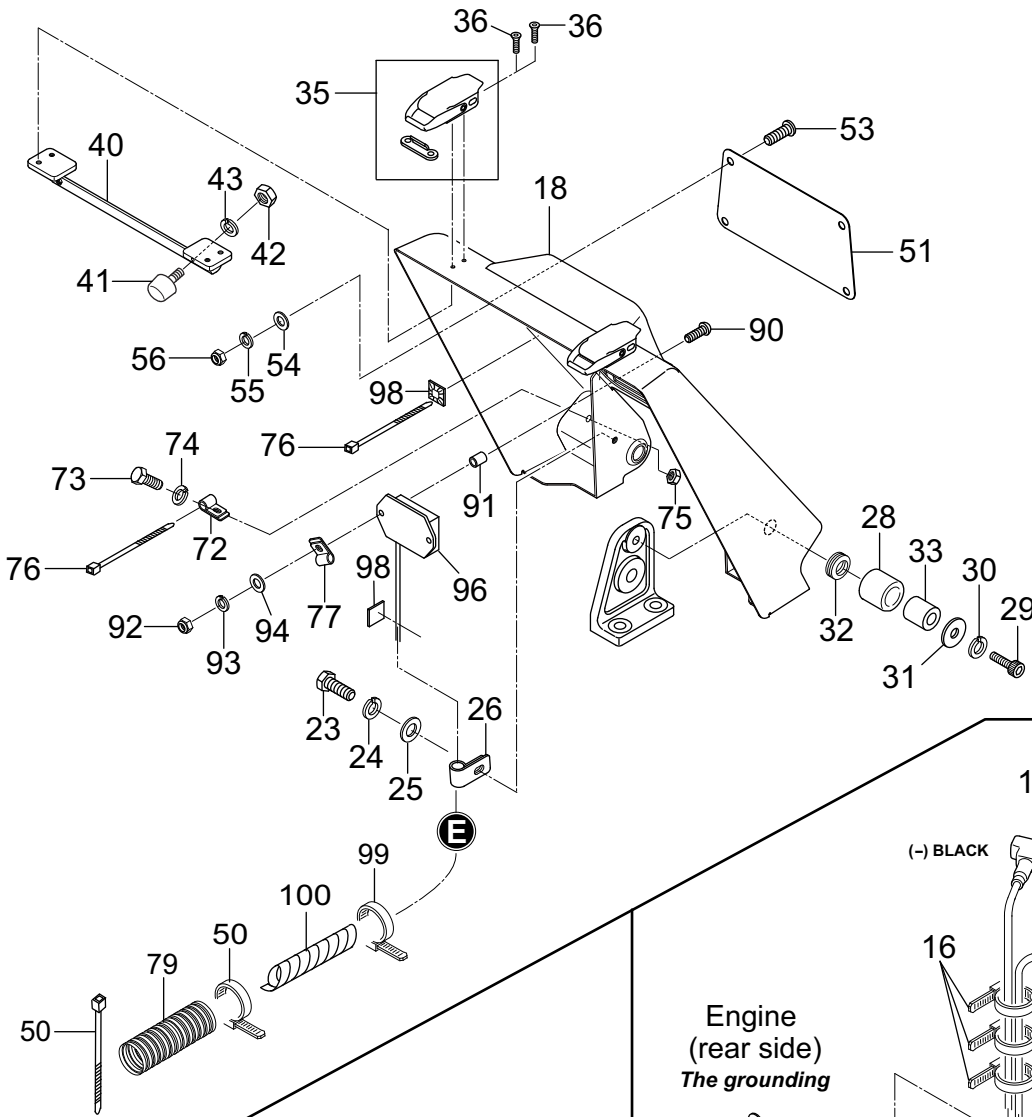

Engine  
(front side)

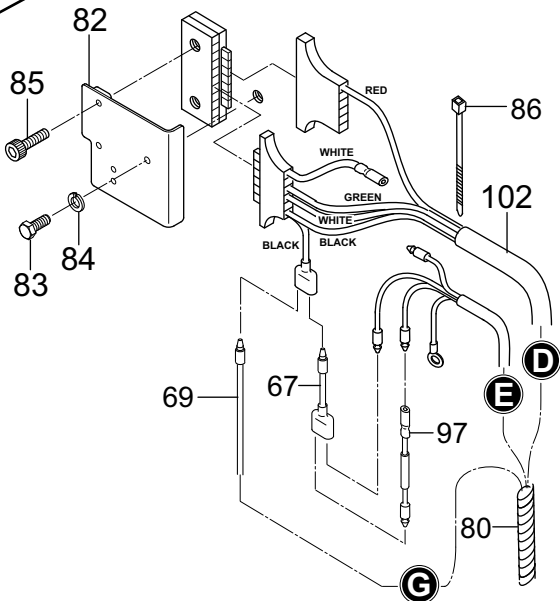

Engine  
(rear side)  
The grounding

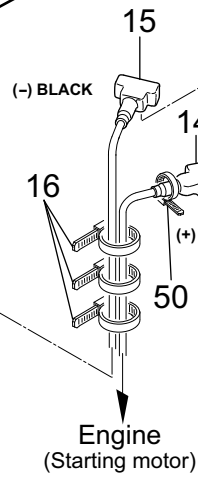
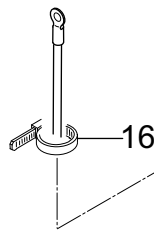

# 4UV0

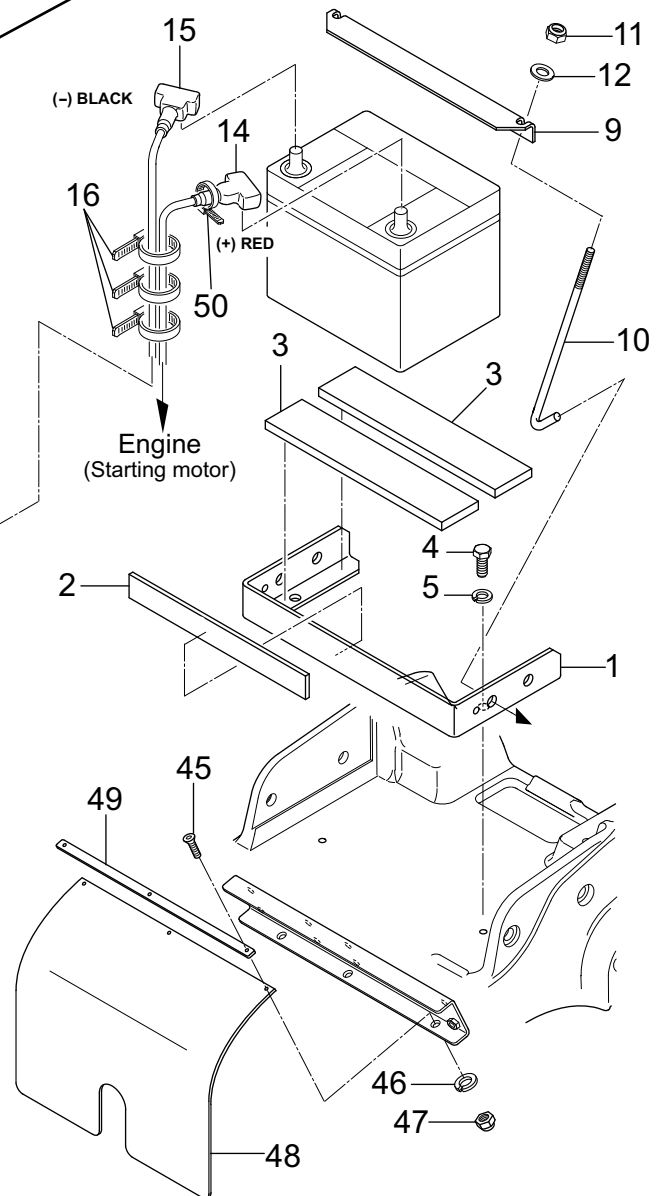
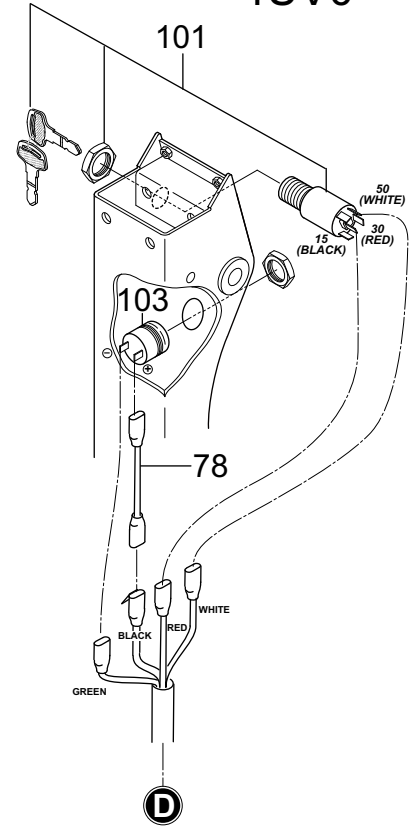



**MVH-508**  
CONTROL

4UC0

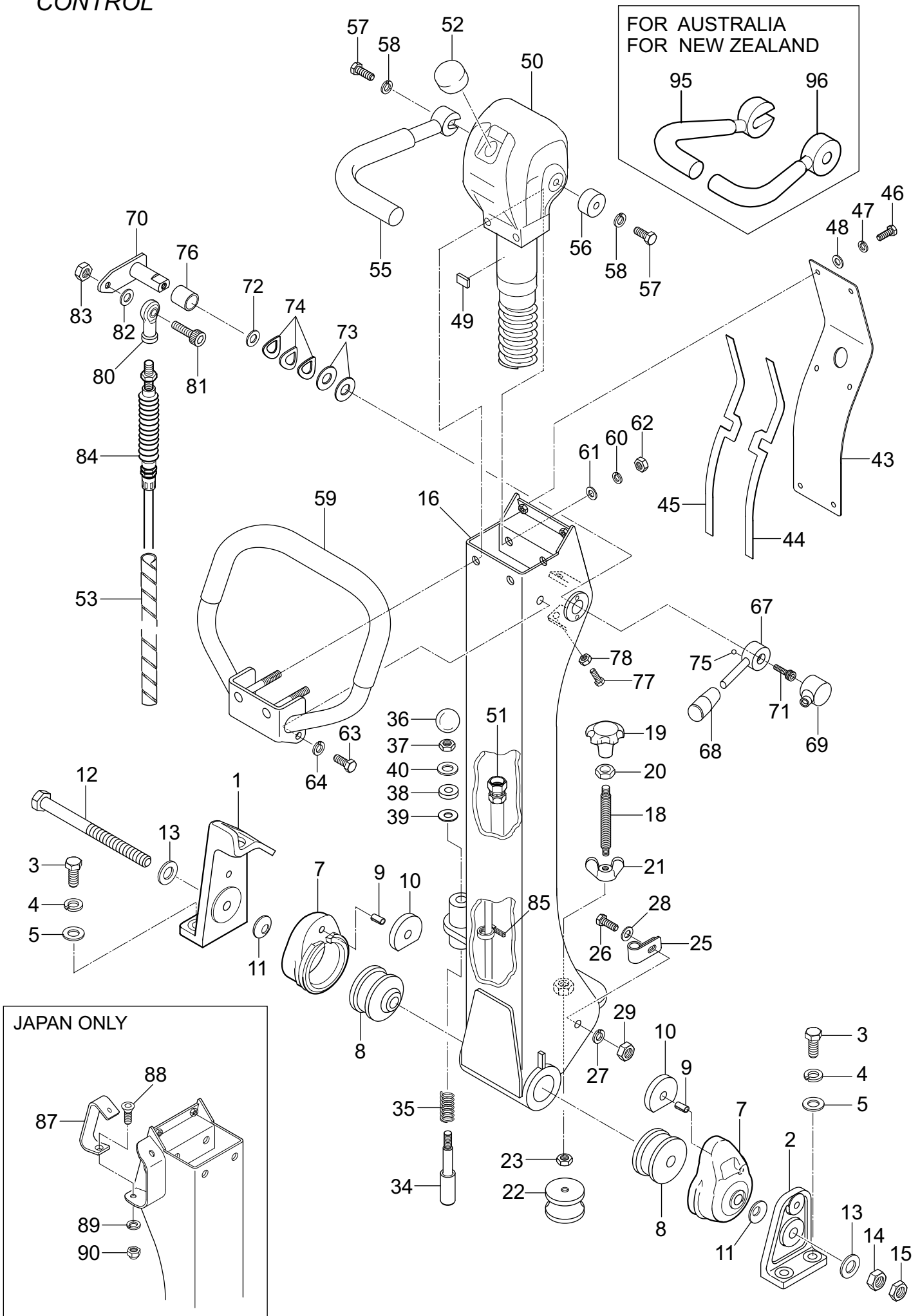

# MVH-508

2014/4/25

## CONTROL

\*\* 4UC \*\*

REF NO.	PART NO.	PART NAME	Q' TY	MRK	MK2	REMARKS
1	4673-51950	HANDLE BRACKET (R) /MVH-308	1			
2	4673-51960	HANDLE BRACKET (L) /MVH-308	1			
3	0012-21235	BOLT 12X35 T	4			
4	0302-12300	SW M12	4			
5	0311-12230	PW M12	4			
7	4563-36400	RUBBER COUPLING/MVH303DSA	2		SX	
8	4564-49940	SHOCK ABSORBER/MVH-303DSA	2			
9	0254-06016	SPRING PIN 6X16	2			
10	4564-49930	RUBBER PLATE /MVH-303DSA	2			
11	0321-24400	CONICAL SPRING WASHER M24	2			
12	0012-21681	BOLT 16X250 T	1			
13	0311-16260	PW M16	2			
14	0203-16130	NUT M16	1			
15	0204-16100	NUT M16, H=10	1			
16	4671-21170	HANDLE BAR /MVH-308DSZ	1			
18	4554-34950	SPINDLE /MVH-200	1		SX	
19	4550-10030	KNOB /MVH-200	1			
20	0204-12070	NUT M12, H=7	1			
21	0224-11635	WING NUT M16	1			
22	9390-10060	SHOCK ABSORBER 60/MVH-200	1			
23	0204-10060	NUT M10, H=6	1			
25	9594-08930	CLIP 15(M6) /MVH-308	1			
26	0012-20620	BOLT 6X20 T	1			
27	0302-06150	SW M6	1			
28	0311-06100	PW M6	1			
29	0203-06050	NUT M6	1			
34	5014-02870	HANDLE STOPPER /MDR	1		SX	
35	5014-02880	SPRING/HANDLE (1. 4X18X44)	1			
36	9594-03460	BALL GRIP 32D-M10	1			
37	0204-10060	NUT M10, H=6	1			
38	4564-49980	RUBBER PACKING 9D-20D-5T	1			
39	9534-05260	PACKING 1/4 (CU)	1			
40	0311-10160	PW M10	1			
43	4673-51970	HANDLE COVER/MVH-306DSZ	1			
44	4674-67340	PACKING(L), HANDLE/MVH-308	1			
45	4674-67350	PACKING(R), HANDLE/MVH-308	1			
46	0012-20615	BOLT 6X15 T	6			
47	0302-06150	SW M6	6			
48	0311-06100	PW M6	6			
49	4644-57930	RUBBER PIECE (T2)/MVH-306	1			
50	4692-19180	HAND PUMP (EXP.) /MVH-508	1			
51	9540-03100	OIL HOSE 1200L /MVH-308	1			
52	4584-51630	BREATHER CAP/ MVH-100/150	1			
53	9590-21813	SPIRAL TUBE 6D-650L	1			
55	4642-16630	TRAVEL LEVER /MVH-306	1		SX	
56	4644-57400	HANDLE BOSS/MVH-306	1			
57	0012-21030	BOLT 10X30 T	2			
58	0302-10250	SW M10	2			
59	4672-18900	GRIP /MVH-308	1			
60	0302-10250	SW M10	2			
61	0311-10160	PW M10	2			
62	0203-10080	NUT M10	2			
63	0012-21025	BOLT 10X25 T	2			
64	0302-10250	SW M10	2			
67	4674-67380	THROTTLE LAVER/MVH-308DSY	1			
68	9594-03840	BAR GRIP, I. D. 12MM	1			
69	4644-57420	COVER , THROTTLE LEVER/306	1			
70	4644-57350	ARM, THROTTLE / MVH-306	1			
71	0015-20820	SOCKET HEAD BOLT 8X20 T	1			
72	0311-16260	PW M16	1			

**MVH-508**  
CONTROL

4UC0

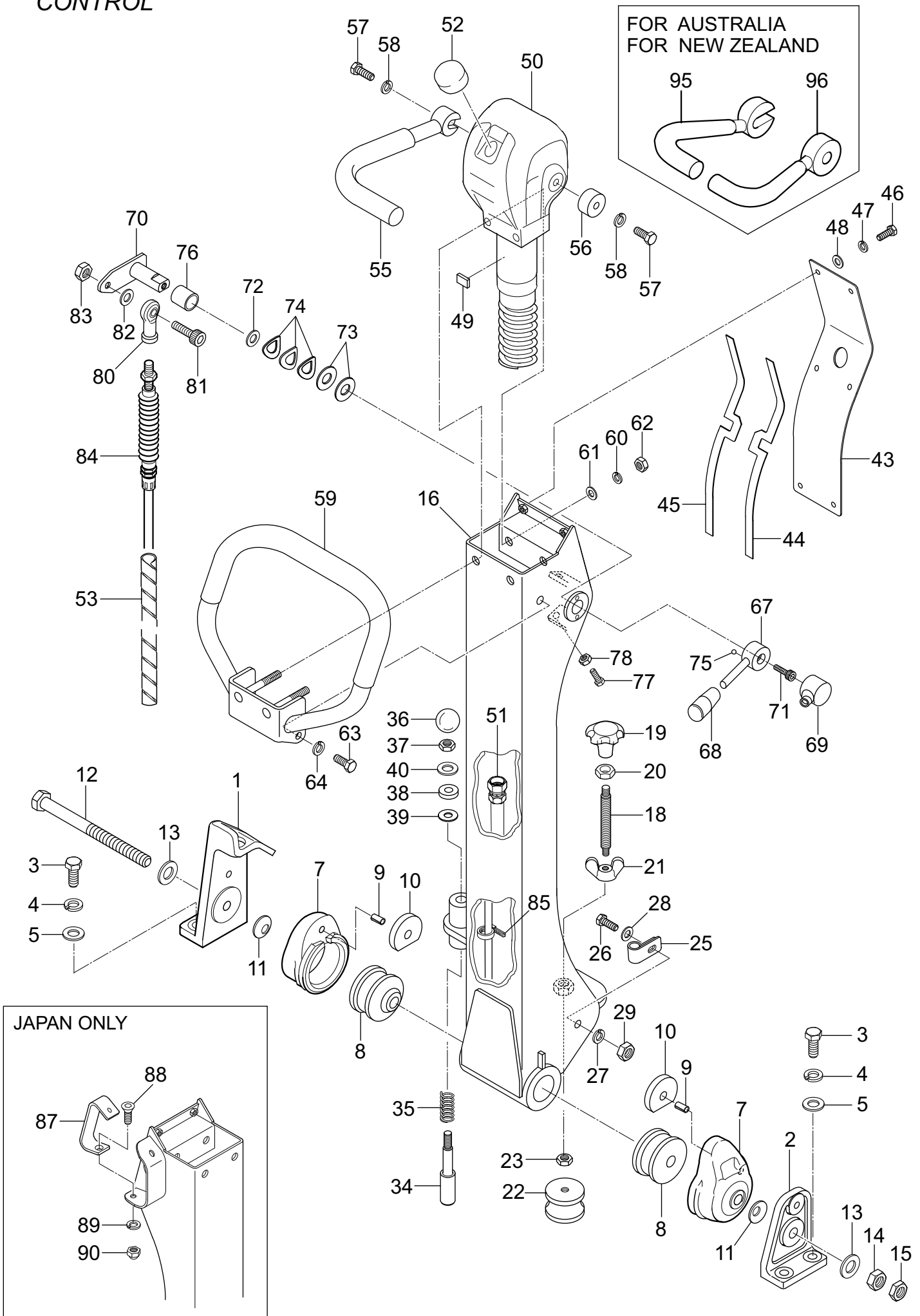





**MVH-508**  
 DECAL AND NAME PLATE (OVERSEAS)

4UD0

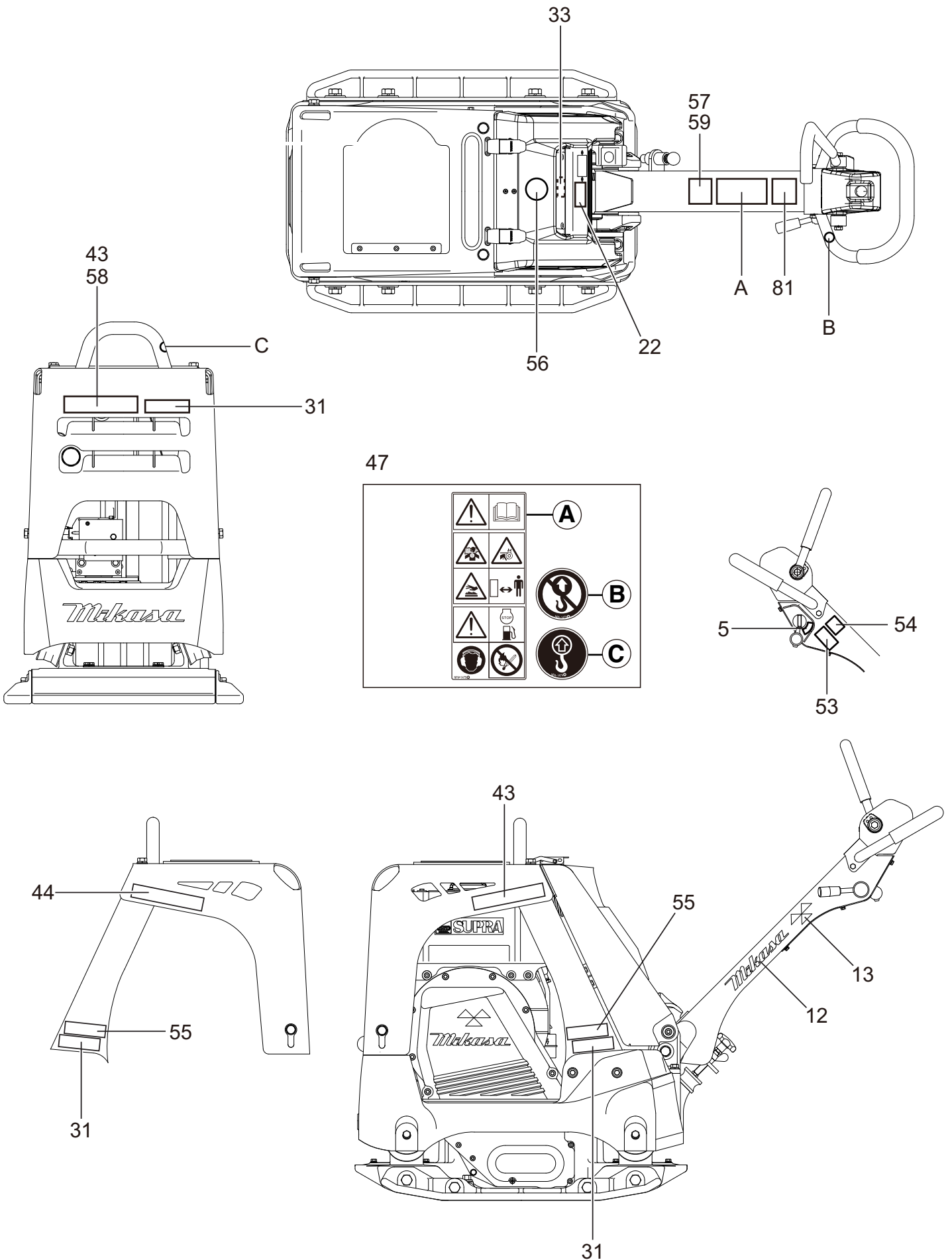





**MIKASA SANGYO CO., LTD.**

HEAD OFFICE  
No.4-3, Sarugakucho 1-chome,  
Chiyoda-ku, Tokyo, 101-0064,  
Japan

<http://www.mikasas.com>