

PARTS LIST

HONDA ENGINE
GX160UT2-QMX2

FOR MIKASA PRODUCTS

WITH PRODUCT NAME

VIBRATING PLATE COMPACTOR

MVC-T90H	:EXPORT
MVC-T90HVAS	:EXPORT
MVC-88VTH	:EXPORT
MVC-88VTHW	:EXPORT

PARTS REMARK INDEX

How to read the marks and remarks used in this parts book.

Section 1 : Explanation of Code Use In “MRK” Column

OO : Interchangeable between the new part and the old one.

XX : Not Interchangeable between new and old.

OX : New part is usable for the old machine but the old part is not usable for the new machine.

XO : The old part is usable for the new machine but the new part is not usable for the old machine.

Note : In case of the lack of interchangeability between the new part and old part, a new part may be used by replacing all other parts found in the assembly. In this case, refer to section 2 for instruction on identifying other parts involved in a new assembly.

AD : Newly established(added)

DC : Suspended(discontinued)

NC : Part number changed

QC : Quantity used has been changed

NS : Not supplied individually but supplied in an assembly or a group.

AS : Special part designed to allow interchangeability between new and old part.

CR : Correction

Section 2 : Items Found In “Remark” Column

Serial Numbers - Where indicated, this indicates a serial number range (inclusive) where a particular part is used.

Model Number - Where indicated, this shows that the corresponding part is utilized only with this specific model number or model number variant.

or * : All parts with the same number following # or * belong to the same assembly. this part cannot be interchanged individually with any other assemblies to replace an old part (indicated by #), with a new part(indicated by *), then all other parts of that assembly must be replaced with new ones.

Note : If more than one of the same reference number is listed, the last one listed indicates newest(or latest)part available.

Section 3: Example

REF NO.	PART NO.	PART NAME	QTY	MRK	REMARKS
457(1)	5122-09230	Hinge Metal, Upper/24g	1		-1070 #3 (5)
457(2)	5072-09420	Hinge Metal, Upper M16	1	OX(3)	U1071-(6) * 3(7)

(1) Old part

(2) New part

(3) New part usable with old machine, but old part not usable with new machine (reference section 1).

(4) Old part number is used through this machine serial number.

(5) Old part, used in an assembly with other parts marked with #3. To use this part on a new machine, all other parts in this assembly must be replaced with old ones.

(6) New part put into use starting with this serial number and is still current.

(7) New part used in an assembly with other parts marked * 3, to use this part as a replacement for an old part, all other * 3 marked parts must be changed at the same time.

Section 4: Items Found In “MK2” Column

(only for suspended products)

! OO (“OO” is shown in figure) : The part shown in lower line is supplied.

! SD : Not available due to termination of production.

! NS : Not supplied individually, but supplied in an assembly or a group.

! PD : Supplied as unit product.

SS : Not available after stock run out.

(The contents of this parts catalog are subject to change without notice.)

GX160UT2-QMX2
CYLINDER HEAD

BMA0

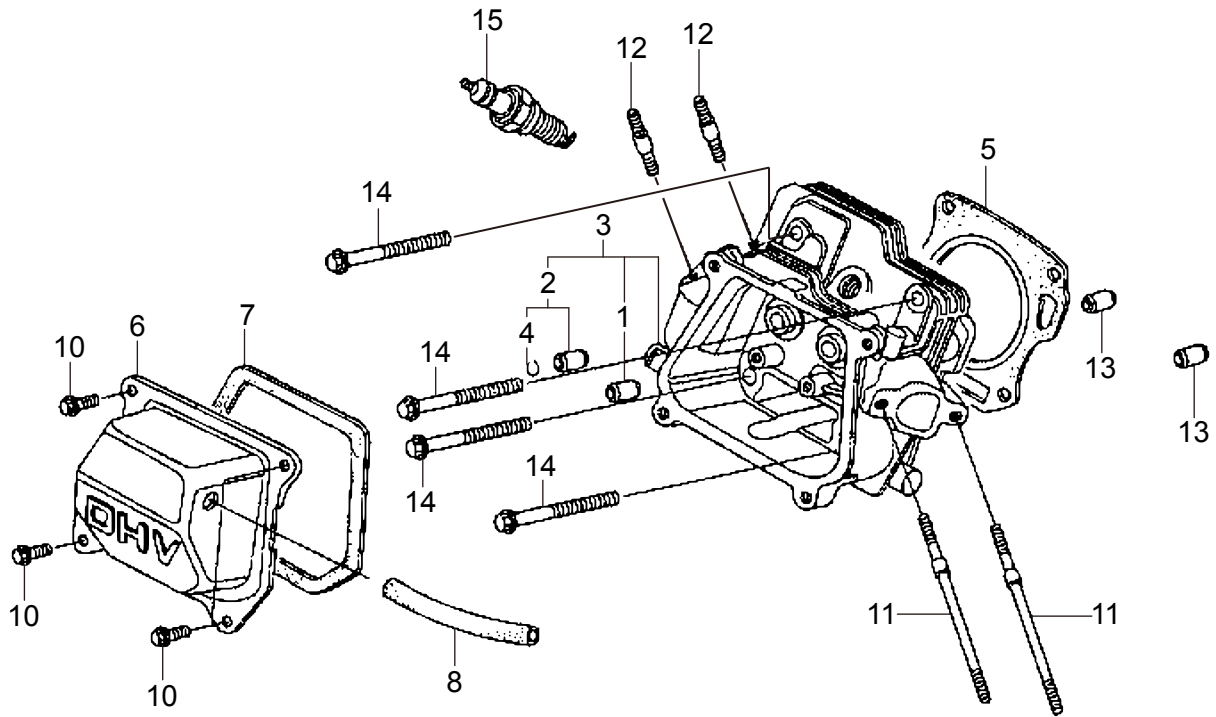

GX160UT2-QMX2 CYLINDER BARREL

BMB0

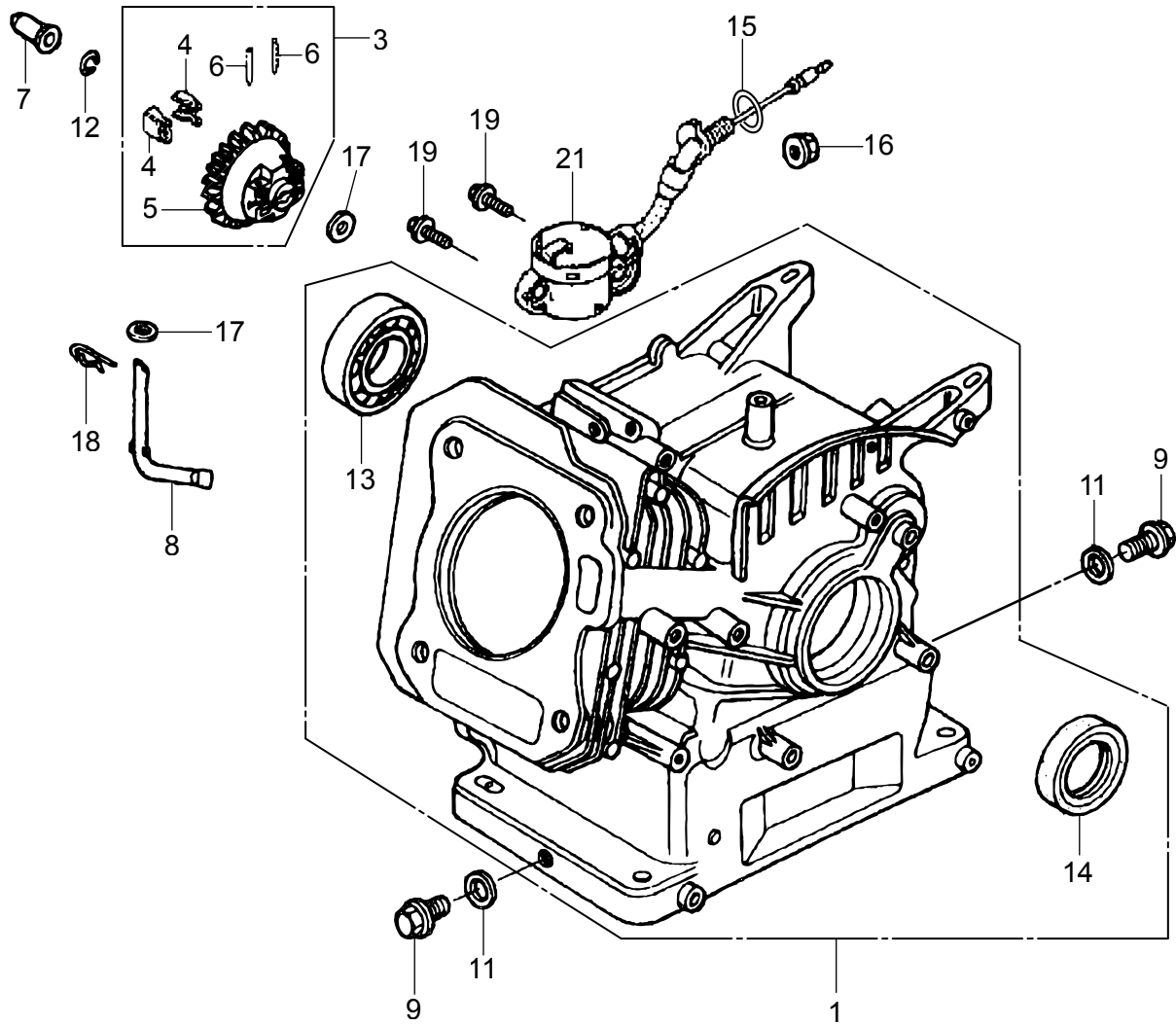

GX160UT2-QMX2
CRANKCASE COVER

BMC0

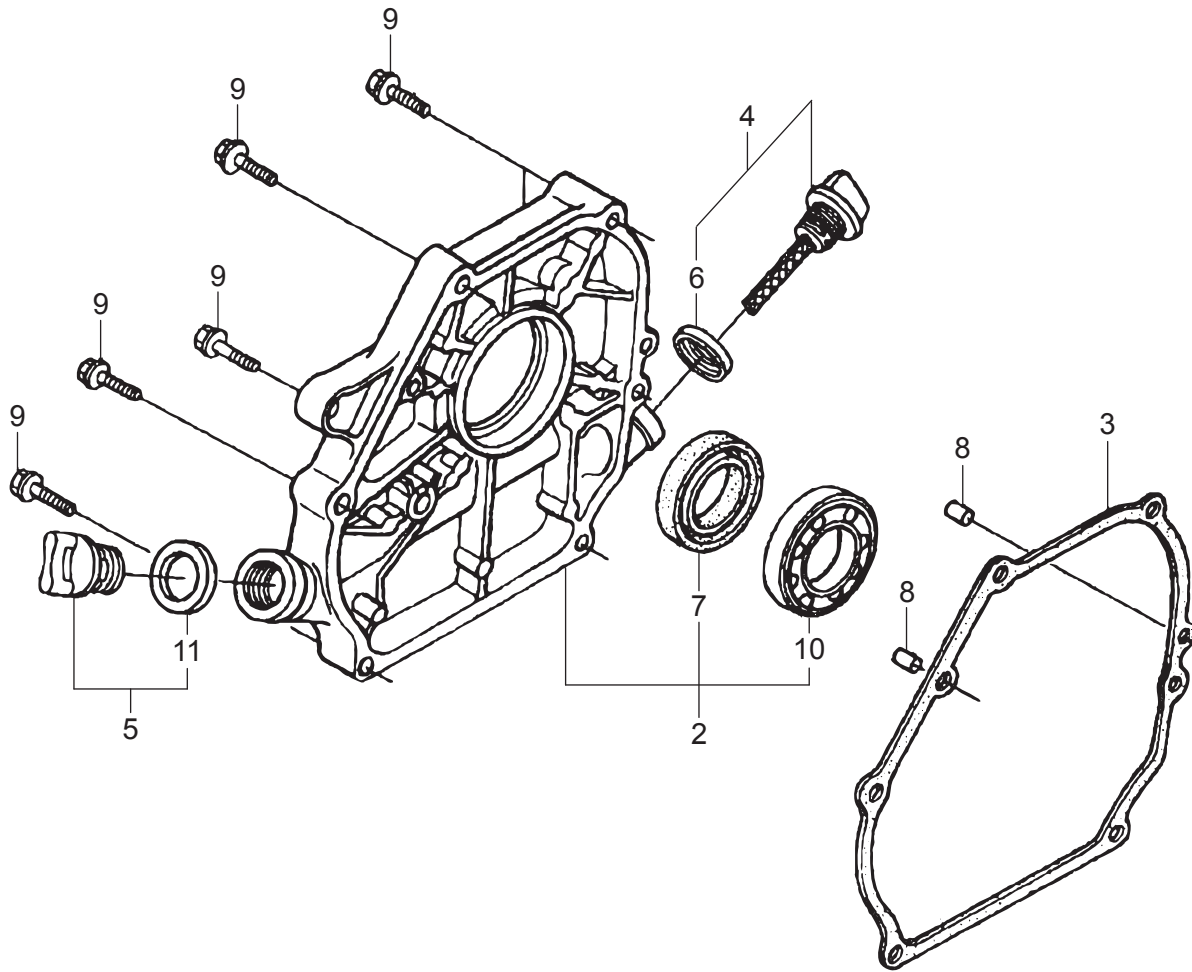

GX160UT2-QMX2
CRANKSHAFT

BMD0

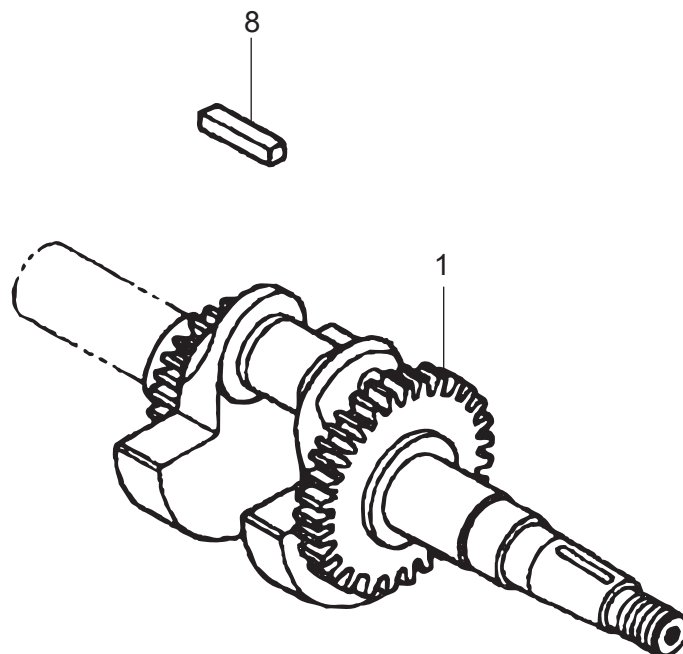

GX160UT2-QMX2
PISTON

BME0

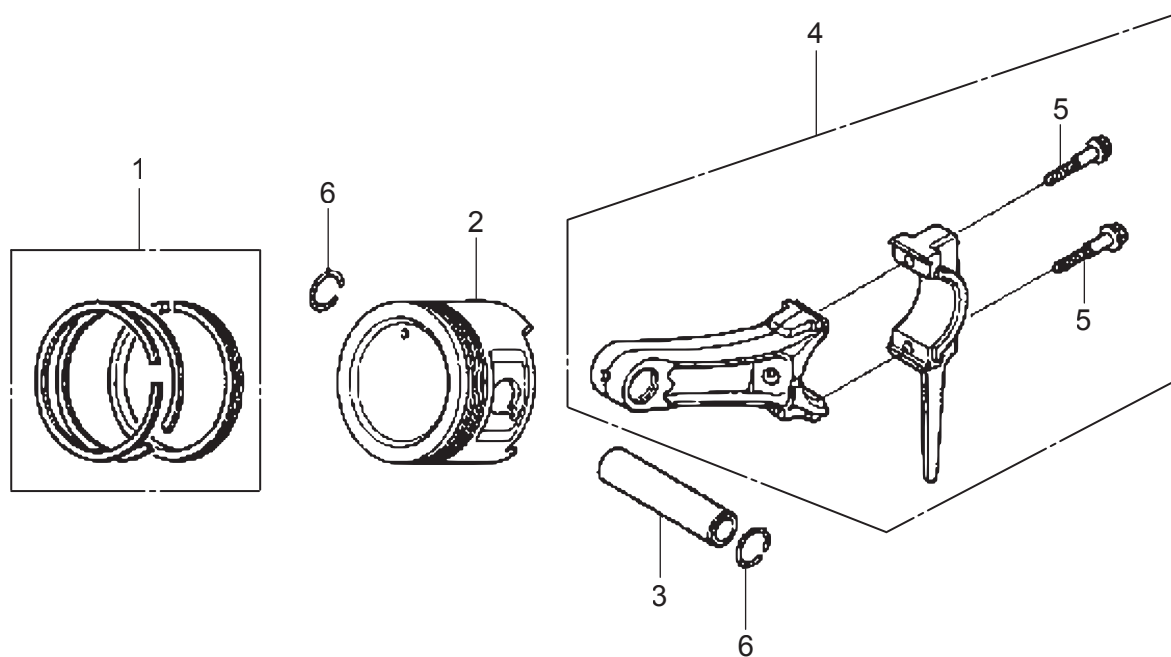

GX160UT2-QMX2
CAMSHAFT

BMF0

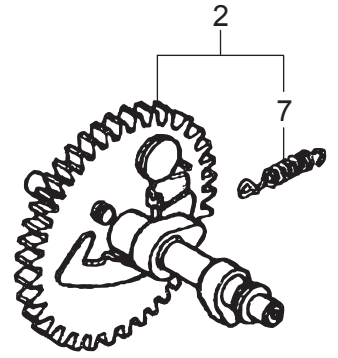
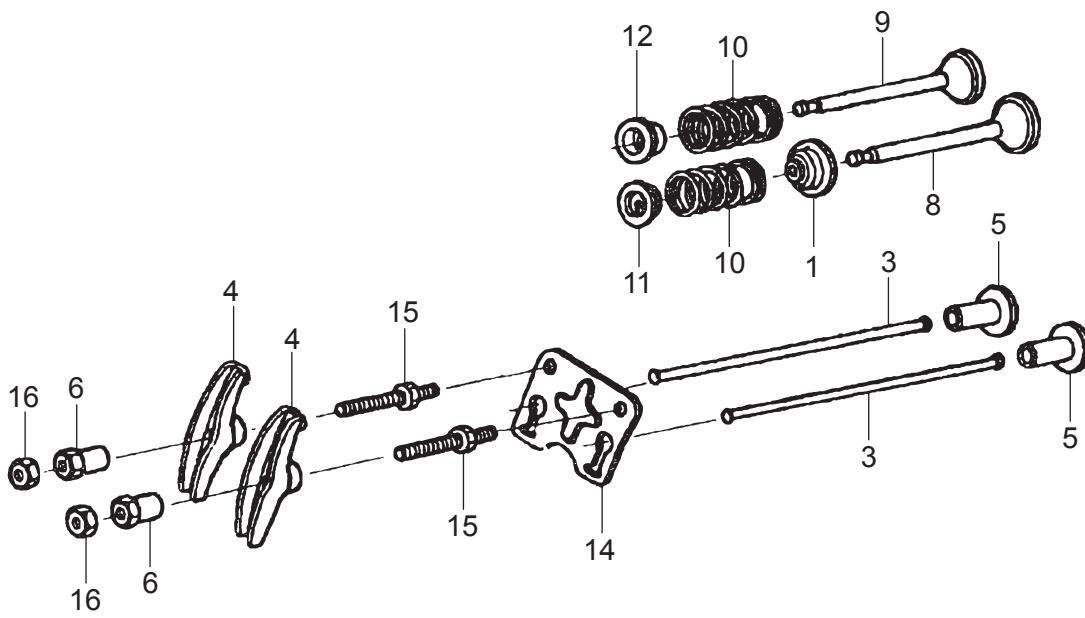

GX160UT2-QMX2
RECOIL STARTER

BMG0

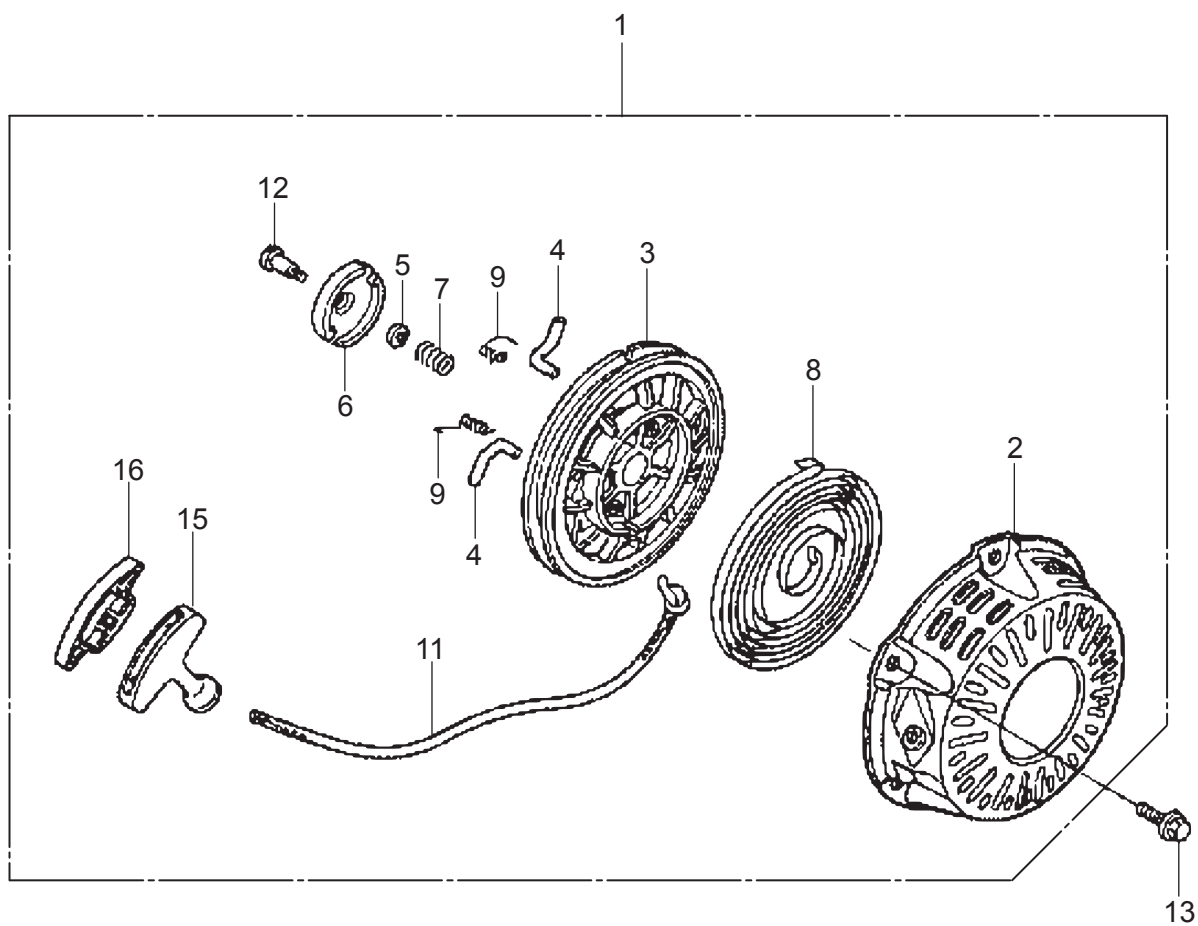

GX160UT2-QMX2
FAN COVER

BMH0

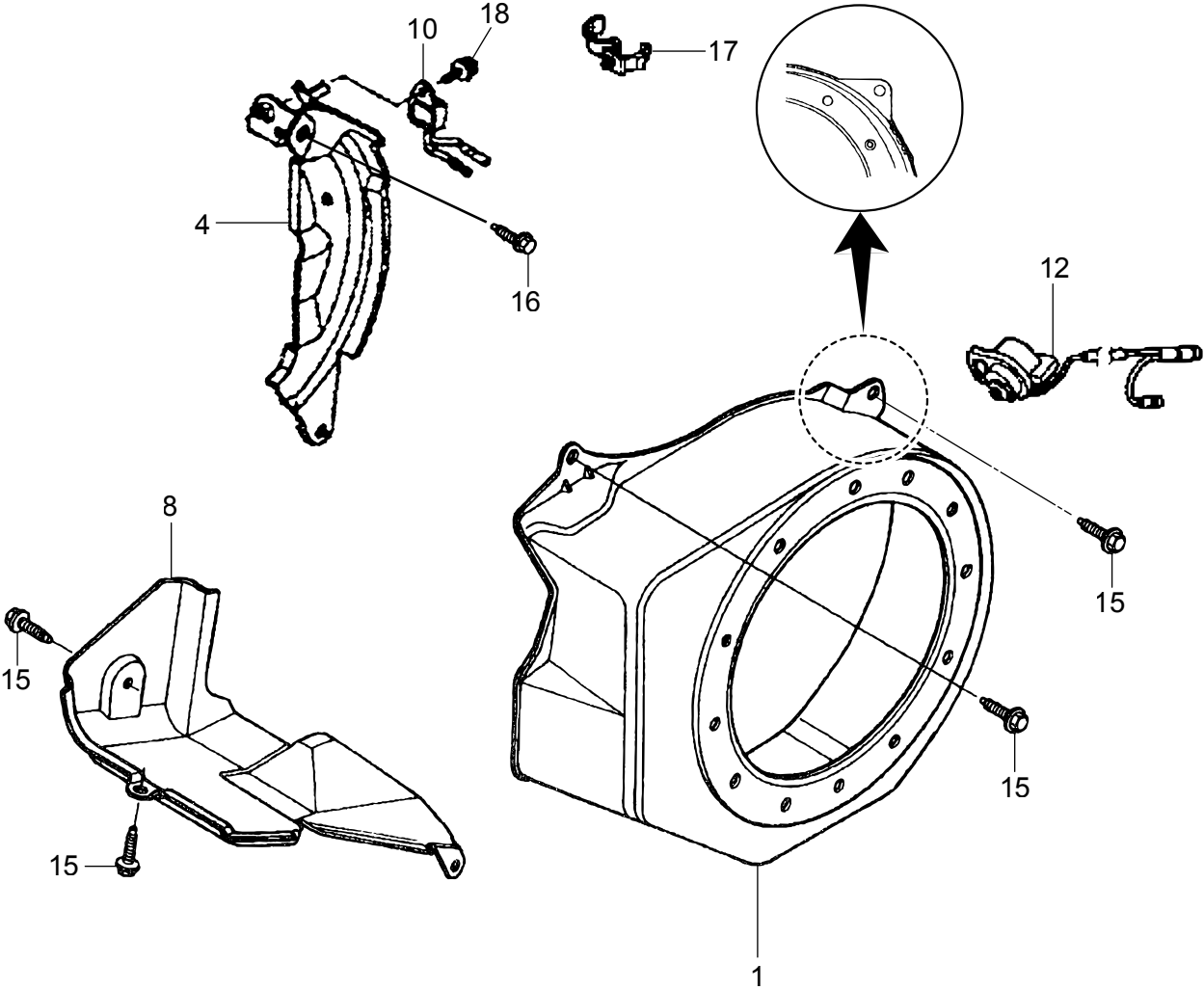

GX160UT2-QMX2
CARBURETOR

BM10

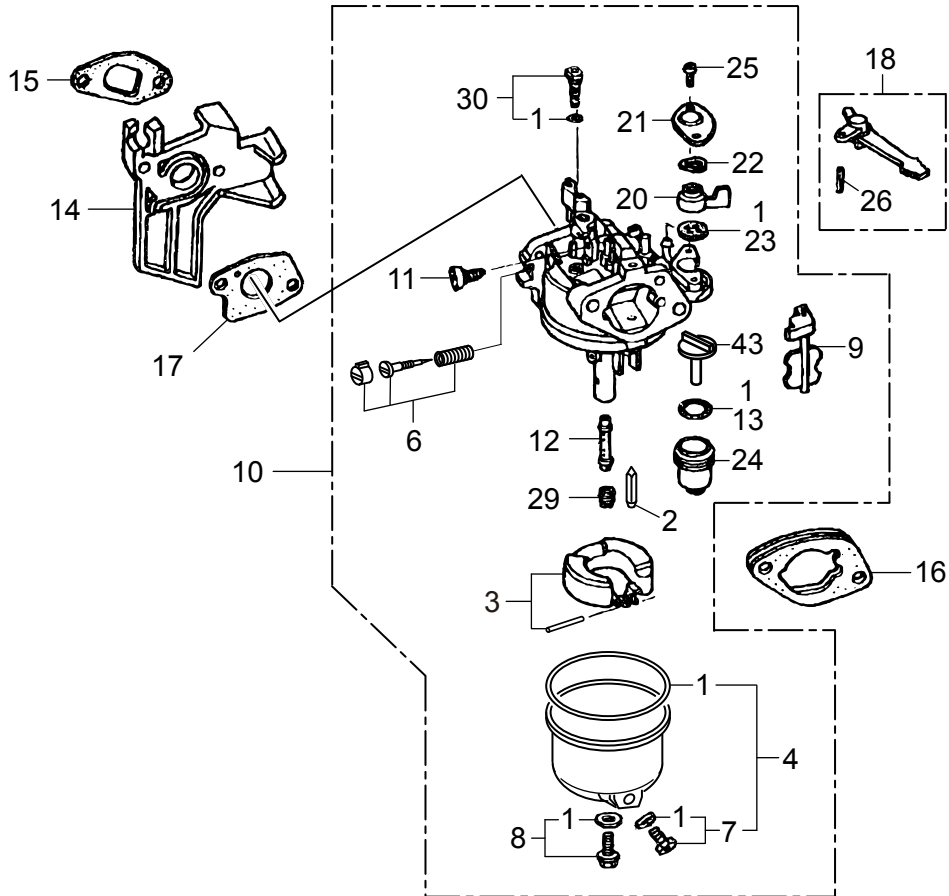

GX160UT2-QMX2 AIR CLEANER

BMJ0

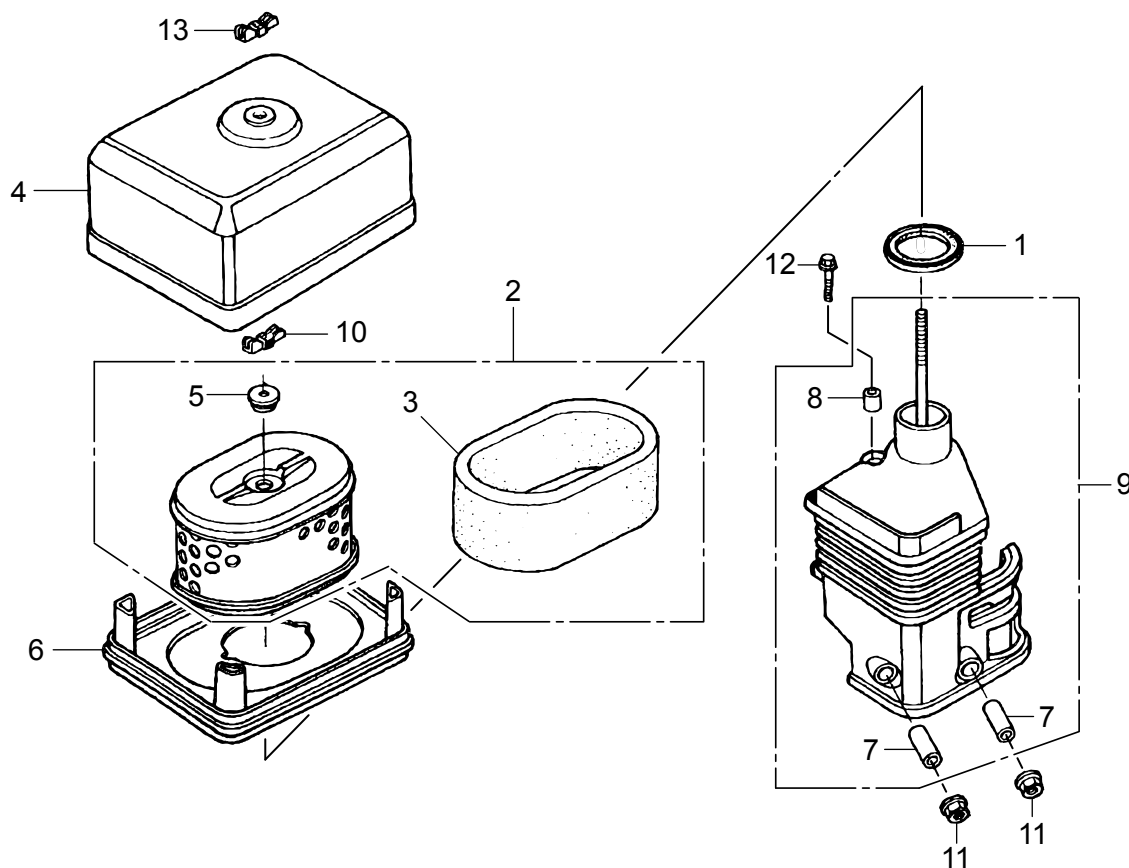

GX160UT2-QMX2 MUFFLER

BMK0

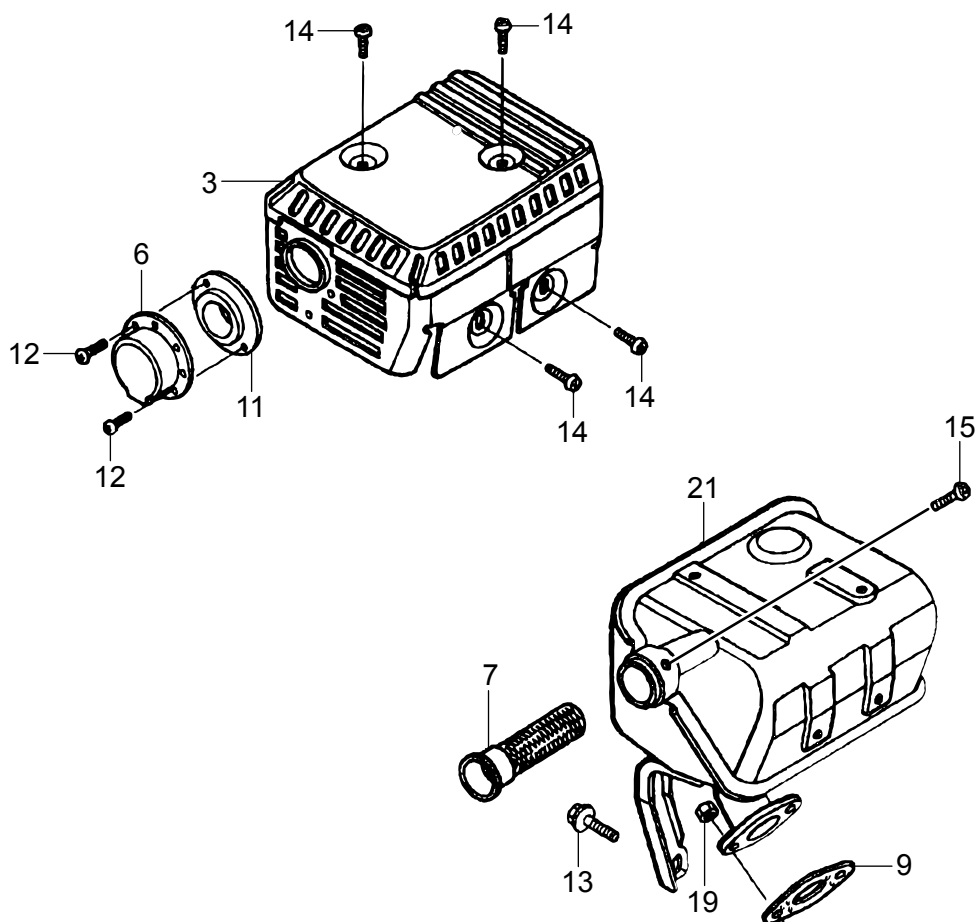

GX160UT2-QMX2 FUEL TANK

BML0

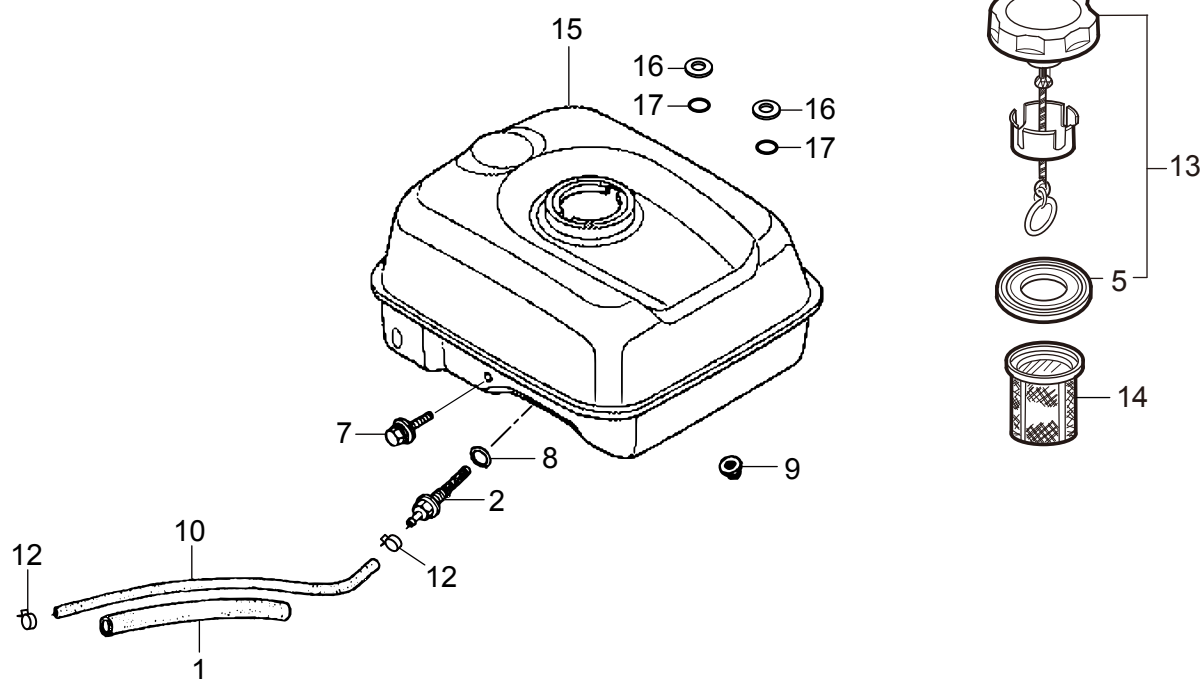

GX160UT2-QMX2
FLYWHEEL

BMM0

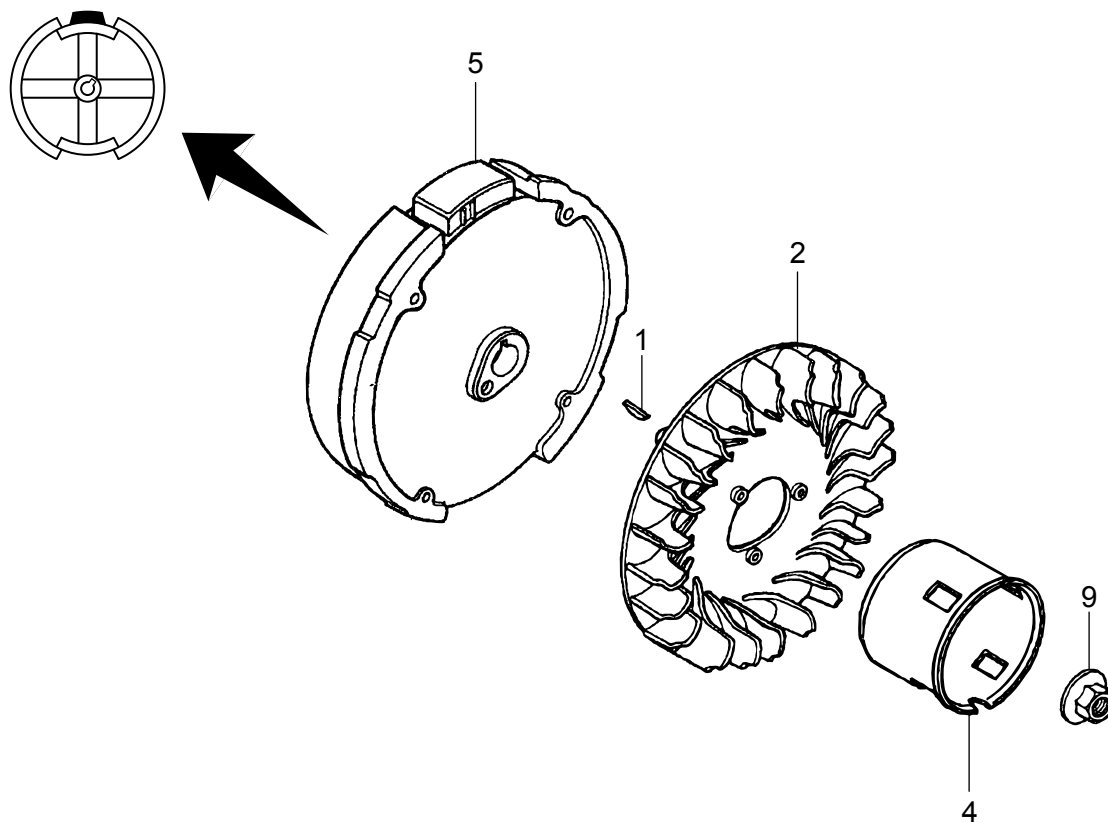

GX160UT2-QMX2
IGNITION COIL

BMN0

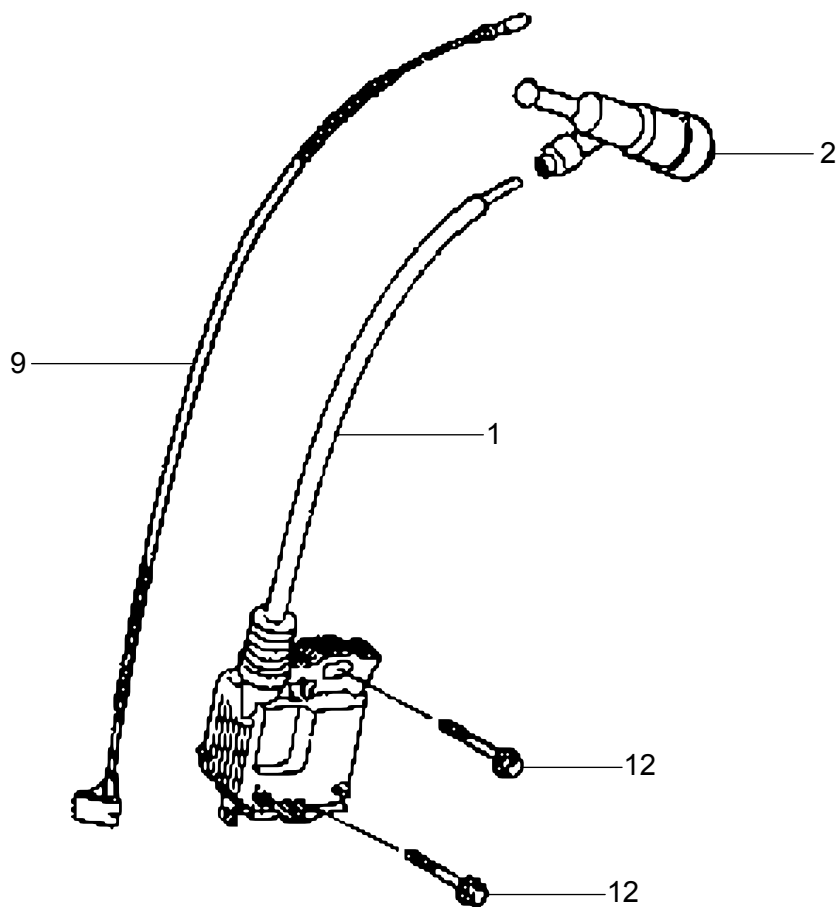

GX160UT2-QMX2
CONTROL

BMO0

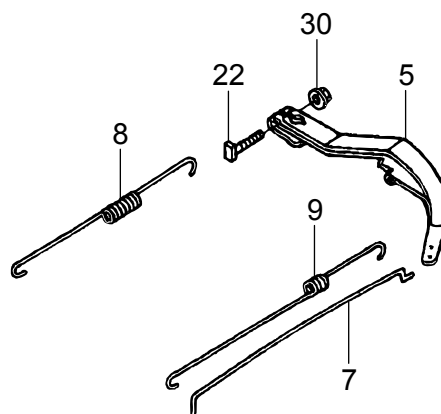
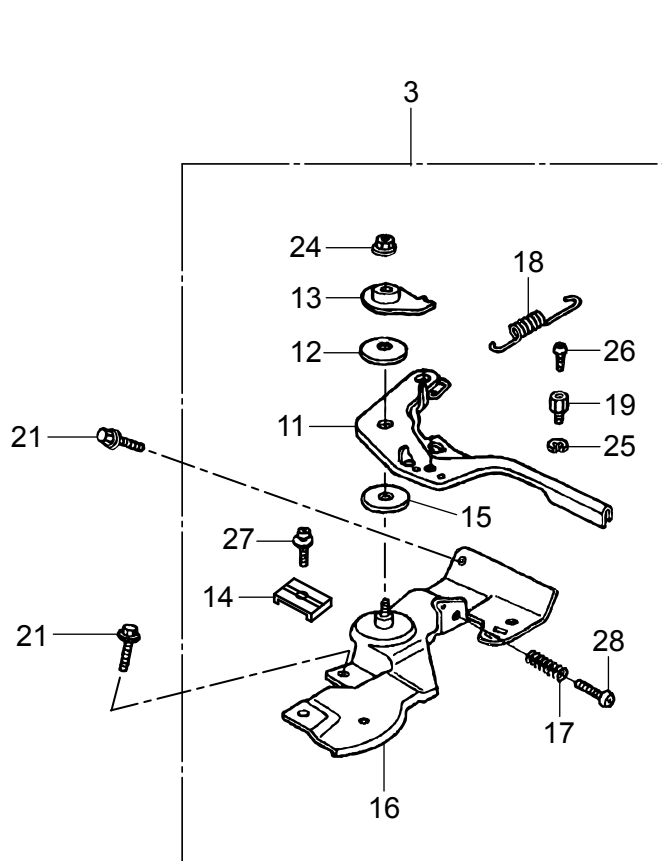

GX160UT2-QMX2 LABEL & TOOL

BMP0

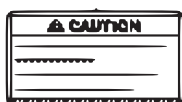
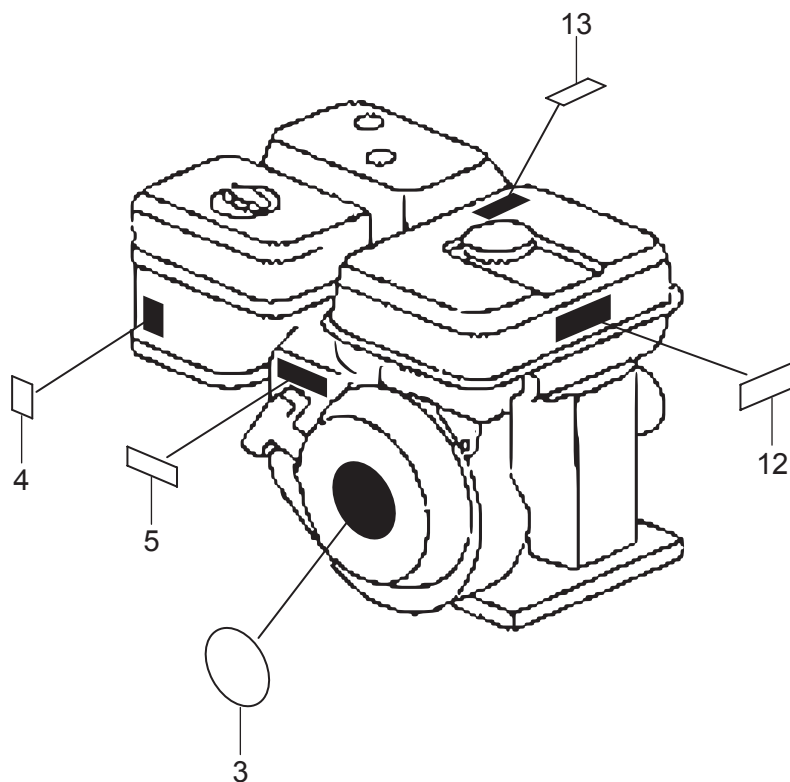

14



15



16



17

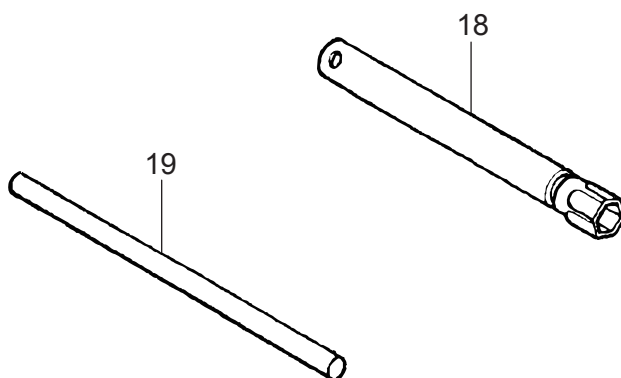

18

19



MIKASA SANGYO CO., LTD.

HEAD OFFICE

No.4-3, Sarugakucho 1-chome,
Chiyoda-ku, Tokyo, 101-0064,
Japan

<http://www.mikasas.com>