



# SPARE PARTS MANUAL

## FLEXTOOL PORTATROWEL<sup>®</sup> FPT30



Version 3.0 (October 2023)

FOR MORE INFORMATION VISIT [flextool.com.au](https://flextool.com.au)

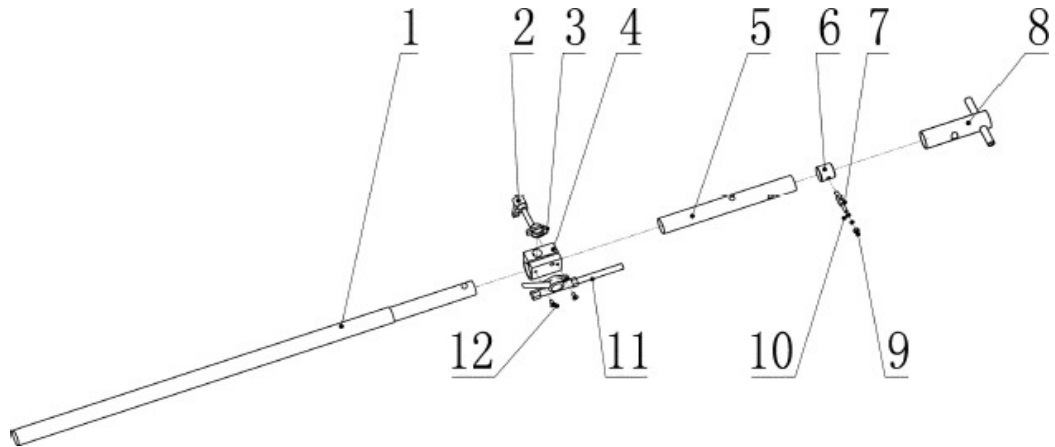

**Clip-Together Handle (FPT30)**

Item No.	Product Code	Description	Qty	Remarks
1	FT401806-UNIT	FLX HANDLE CLIP TOGETHER 1.8M (FX-H-CLIP)	1	
2	NPS00348-UNIT	FLX SCREW HANDLE M10 X 40 (SY-R-CPT430-1040)	1	
3	NPS00739-UNIT	HON SWITCH ASSY ENGINE STOP (H35120-Z0T-831)	1	
4	NPS07509-UNIT	FLX PORTATROWEL CLAMP (SY-B-CZG-4303102)	1	
5	NPS07510-UNIT	FLX CONNECTION ADAPTOR (SY-B-CZG-4303103)	1	
6	NPS07511-UNIT	FLX PIVOT BUSH (SY-B-CZG-4303104)	1	
7	NPS07512-UNIT	FLX PIN SHAFT (SY-B-CZG-4303105)	1	
8	NPS07513-UNIT	FLX T PIECE CONNECTION ADAPTOR (SY-B-CZG-4303106)	1	
9	NPS07279-UNIT	FLX NY-LOCK NUT M6 (SY-GB/T6170-06)	1	
10	NPS07514-UNIT	FLX COLLAR (SY-B-CZG-4303107)	2	
11	NPS00347-UNIT	FLX THROTTLE CABLE & CTL ASSY FPT30 (SY-R-CPT430-0518)	1	
12	NPS07515-UNIT	FLX SCREW M6 X 12MM (SY-GB/T70.3-06-12)	2	

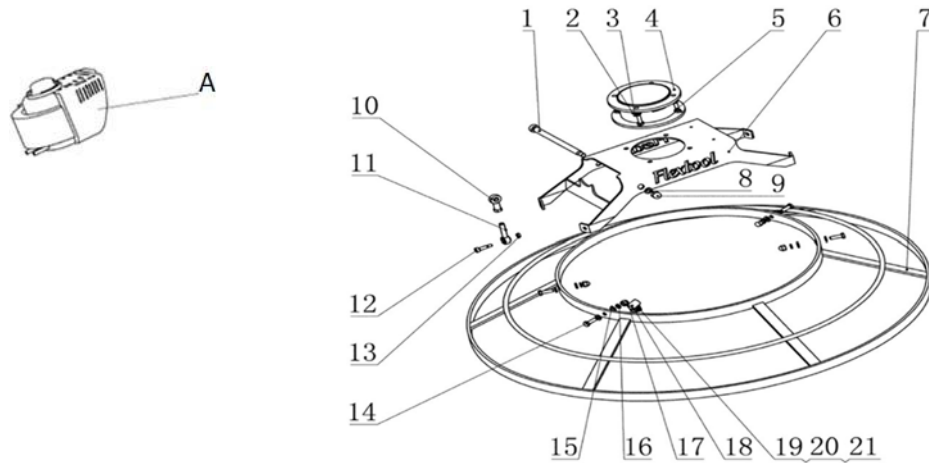

Blade Guard and Engine (FPT30)

Item No.	Product Code	Description	Qty	Remarks
A	NPS03318-UNIT	HON ENGINE GX35 (F03318)	1	
1	NPS00345-UNIT	FLX SCREW M10 X 140MM (SY-R-SDLS10X140)	1	
2	NPS07267-UNIT	FLX WASHER FLAT M6 (SY-GB/T95-06)	4	
3	NPS07268-UNIT	FLX WASHER SPRING M6 (SY-GB/T93-06)	4	
4	NPS07516-UNIT	FLX SUPPORT FRAME BOSS (SY-B-FFQ-4303301)	1	
5	NPS07269-UNIT	FLX BOLT M6X20 (SY-B-226-CL021)	4	
6	NPS00343-UNIT	FLX ENGINE MOUNTING PLATE (SY-B-FFQ-4303302)	1	
7	NPS00344-UNIT	FLX GUARD RING (SY-B-FFQ-4303303)	1	
8	NPS07228-UNIT	FLX WASHER FLAT M8 (SY-GB/T95-08)	1	
9	NPS07517-UNIT	FLX DOME NUT M8 (SY-GB/T923-08)	1	
10	NPS07518-UNIT	FLX BALL JOINT FEMALE (SY-R-GJZC-ST6)	1	
11	NPS07519-UNIT	FLX BALL JOINT MALE (SY-R-GJZC-SA6)	1	
12	NPS07520-UNIT	FLX SHOULDER SCREW M6 X 16MM (SY-R-LZQL642)	1	
13	NPS07521-UNIT	FLX NUT M5 (SY-R-Z0000367)	1	
14	NPS07269-UNIT	FLX BOLT M6X20 (SY-B-226-CL021)	4	
15	NPS07267-UNIT	FLX WASHER FLAT M6 (SY-GB/T95-06)	8	
16	NPS07268-UNIT	FLX WASHER SPRING M6 (SY-GB/T93-06)	4	
17	NPS07522-UNIT	FLX DOME NUT M6 (SY-R-Z0000369)	4	
18	NPS07523-UNIT	FLX RUBBER SLEEVED BRACKET (SY-R-XPX-M12)	1	
19	NPS07524-UNIT	FLX SCREW M6 X 16MM (SY-GB/T70.1-06-016)	2	
20	NPS07267-UNIT	FLX WASHER FLAT M6 (SY-GB/T95-06)	8	
21	NPS07279-UNIT	FLX LOCK NUT M6 (SY-GB/T6170-06)	1	

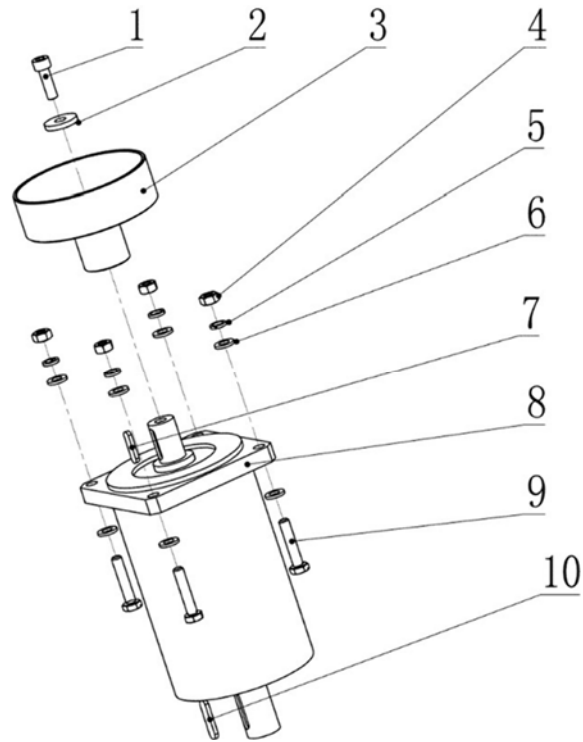

**Gearbox Assembly (FPT30)**

Item No.	Product Code	Description	Qty	Remarks
1	NPS07525-UNIT	FLX SCREW M5 X 30MM (SY-GB/T70.3-05X30)	1	
2	NPS07526-UNIT	FLX LARGE FLAT WASHER 6MM (SY-R-CPT430-0502)	1	
3	NPS07527-UNIT	FLX CLUTCH DRUM (SY-R-CPT430-0503)	1	
4	NPS07279-UNIT	FLX NY-LOCK NUT M6 (SY-GB/T6170-06)	4	
5	NPS07268-UNIT	FLX WASHER SPRING M6 (SY-GB/T93-06)	4	
6	NPS07267-UNIT	FLX WASHER FLAT M6 (SY-GB/T95-06)	4	
7	NPS07528-UNIT	FLX KEY STEEL 5MM X 20MM (SY-GB/T1096-5-20)	1	
8	NPS07529-UNIT	FLX PORTATROWEL GEARBOX (SY-R-HS090-01)	1	
9	NPS07530-UNIT	FLX SCREW M6 X 30MM (SY-GB/T70.3-06-30)	4	
10	NPS07531-UNIT	FLX KEY STEEL 6MM X 30MM (SY-GB/T1096-06-30)	1	

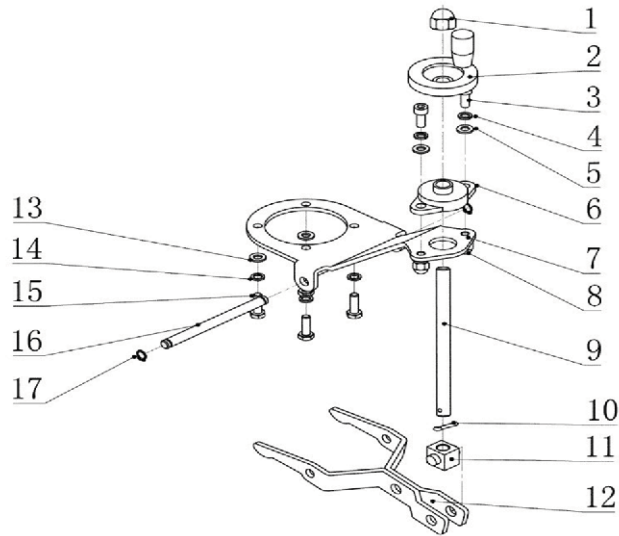

**Blade Pitch Assembly (FPT30)**

Item No.	Product Code	Description	Qty	Remarks
1	NPS07532-UNIT	FLX DOME NUT 10MM (SY-GB/T923-10)	1	
2	NPS07533-UNIT	FLX TURN PITCH KNOB (SY-R-CPT430-0504)	1	
3	NPS07534-UNIT	FLX SCREW M6 X 20MM (SY-GB/T70.3-06X20)	2	
4	NPS07268-UNIT	FLX WASHER SPRING M6 (SY-GB/T93-06)	2	
5	NPS07267-UNIT	FLX WASHER FLAT M6 (SY-GB/T95-06)	2	
6	NPS07535-UNIT	FLX PILLOW BLOCK BEARING (SY-R-LZQL3)	1	
7	NPS07536-UNIT	FLX PITCH CONTROL PLATE (SY-R-CPT430-0401)	1	
8	NPS07279-UNIT	FLX NY-LOCK NUT M6 (SY-GB/T6170-06)	4	
9	NPS07537-UNIT	FLX THREADED SHAFT M10 X 140MM (SY-R-CPT430-0402)	1	
10	NPS07538-UNIT	FLX PIN 2.5MM X 20MM (SY-GB/T91-2.5-20)	1	
11	NPS07539-UNIT	FLX THREADED PIVOT BRACKET (SY-R-CPT430-0505)	1	
12	NPS07540-UNIT	FLX PITCH YOLK (SY-R-CPT430-0506)	1	
13	NPS07267-UNIT	FLX WASHER FLAT M6 (SY-GB/T95-06)	4	
14	NPS07268-UNIT	FLX WASHER SPRING M6 (SY-GB/T93-06)	4	
15	NPS07555-UNIT	FLX SCREW M6 X 20MM (SY-GB/T70.1-6-20)	4	
16	NPS07541-UNIT	FLX SHAFT (SY-R-CPT430-0507)	1	
17	NPS07542-UNIT	FLX SHAFT RETAINING RING (SY-GB/T894.1-8)	2	

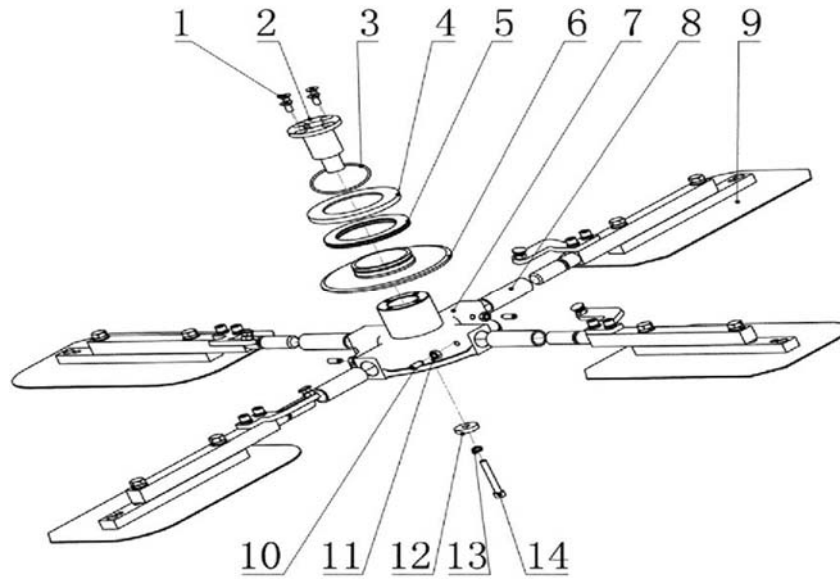

Spider Plate Assembly (FPT30)

Item No.	Product Code	Description	Qty	Remarks
1	NPS07515-UNIT	FLX SCREW M6 X 12MM (SY-GB/T70.3-06-12)	4	
2	NPS07543-UNIT	FLX ADAPTOR HUB (SY-R-CPT430-0501)	1	
3	NPS07544-UNIT	FLX RETAINING RING (SY-R-ZYYDCF23)	1	
4	NPS07545-UNIT	FLX BEARING HOLDER (SY-R-CPT430-0508)	1	
5	NPS07546-UNIT	FLX BEARING (SY-R-PMZC-6085)	1	
6	NPS07547-UNIT	FLX PRESSURE PLATE (SY-R-CPT430-0509)	1	
7	NPS07548-UNIT	FLX SPIDER PLATE FPT30 (SY-B-SZJ-12305)	1	
8	NPS07549-UNIT	FLX SPIDER PLATE ARM BUSH (SY-R-CPT430-0511)	4	
9	See Remarks	FLX TROWEL ARM ASSY FPT30 (SY-B-CPT430-0512)	4	REFER PAGE 7
10	NPS07550-UNIT	FLX GRUBB SCREW M6 X 16MM (SY-R-CPT430-0513)	4	
11	NPS07279-UNIT	FLX NY-LOCK NUT M6 (SY-GB/T6170-06)	4	
12	NPS07551-UNIT	FLX RETAINING WASHER (SY-R-CPT430-0514)	1	
13	NPS07268-UNIT	FLX WASHER SPRING M6 (SY-GB/T93-06)	1	
14	NPS07552-UNIT	FLX SCREW M6 X 50MM (SY-GB/T70.3-06X50)	1	

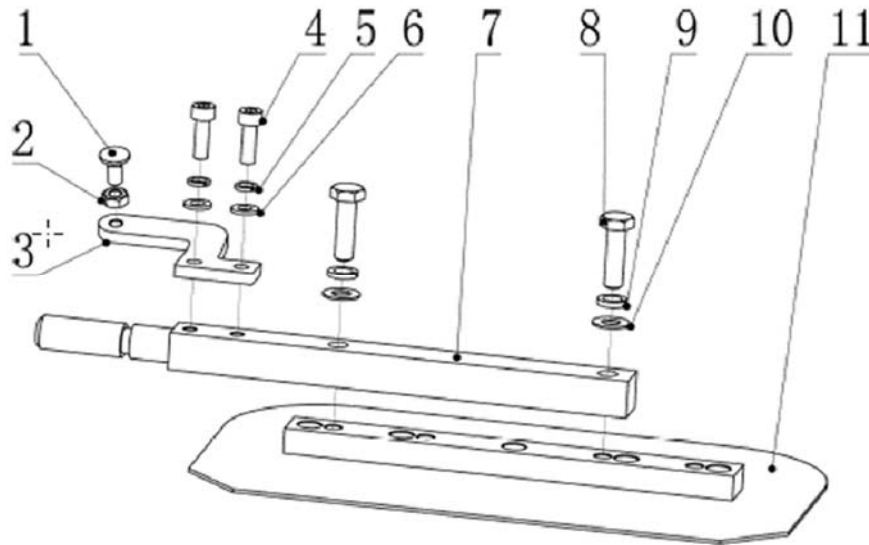

**Blade Arm Assembly (FPT30)**

Item No.	Product Code	Description	Qty	Remarks
1	NPS07553-UNIT	FLX DOME HEAD BOLT M6 X 20MM (SY-MCLS6X20)	4	
2	NPS07279-UNIT	FLX NY-LOCK NUT M6 (SY-GB/T6170-06)	4	
3	NPS07554-UNIT	FLX PITCH ARM FPT30 (SY-R-CPT430-0515)	4	
4	NPS07555-UNIT	FLX SCREW M6 X 20MM (SY-GB/T70.1-6-20)	8	
5	NPS07268-UNIT	FLX WASHER SPRING M6 (SY-GB/T93-06)	8	
6	NPS07267-UNIT	FLX WASHER FLAT M6 (SY-GB/T95-06)	8	
7	NPS00346-UNIT	FLX TROWEL ARM FPT30 (SY-R-CPT430-0516)	4	
8	See Remarks	FLX SCREW M8 X 30MM (SY-GB/T70.3-30)	8	Included with replacement Trowel Blade Set (Item 11)
9	See Remarks	FLX SPRING WASHER 8MM (SY-GB/T93-08)	8	
10	See Remarks	FLX WASHER FLAT M8 (SY-GB/T95-08)	8	
11	FT201533-UNIT	FLX TROWEL BLADE FINISHING FPT30 4PACK (SY-CT-PORTABLADE)	1	



## Flextool

1956 Dandenong Road, Clayton VIC 3168, Australia

Phone (AUS): 1300 353 986

[flextool.com.au](http://flextool.com.au)

ABN 80 069 961 968

This manual summarises our best knowledge of the product based on the information available at the time of publication. You should read this manual carefully and consider the information in the context of how the product will be used. Our responsibility for products sold is subject to our standard terms and conditions of sale.

### DISCLAIMER:

Any advice, recommendation, information, assistance or service provided by us in this manual is given in good faith and is believed by us to be appropriate and reliable. However, any advice, recommendation, information, assistance or service provided by us is provided without liability or responsibility PROVIDED THAT the foregoing shall not exclude, limit, restrict or modify the right entitlements and remedies conferred upon any person or the liabilities imposed upon us by any condition or warranty implied by Commonwealth, State or Territory Act or ordinance void or prohibiting such exclusion limitation or modification. The product can be expected to perform as indicated in this manual so long as operation and operational procedures of the individual products are followed as recommended in this manual.

Design and technical specifications may be subject to changes.

© This publication is copyright. All rights are reserved. Flextool and PortaTrowel are registered trade marks of Parchem Construction Supplies Pty Ltd.