

HONDA ENGINE  
***GX100U-KRBN (EXP)***  
***GX100RT-KRBN (EXP)***  
FOR MIKASA PRODUCTS

805-09501

FOR MODEL

TAMPING RAMMER  
MT-65HA (EXP)

SERIAL NUMBER

GX100U-KRBN for MT-65HA S/N : -Z4858

GX100RT-KRBN for MT-65HA S/N : Z4859-

MIKASA SANGYO CO. , LTD.

# PARTS REMARK INDEX

## How to read the marks and remarks used in this parts book.

### Section 1 : Explanation of Code Use In “MRK” Column

OO : Interchangeable between the new part and the old one.

XX : Not Interchangeable between new and old.

OX : New part is usable for the old machine but the old part is not usable for the new machine.

XO : The old part is usable for the new machine but the new part is not usable for the old machine.

Note : In case of the lack of interchangeability between the new part and old part, a new part may be used by replacing all other parts found in the assembly. In this case, refer to section 2 for instruction on identifying other parts involved in a new assembly.

AD : Newly established(added)

DC : Suspended(discontinued)

NC : Part number changed

QC : Quantity used has been changed

NS : Not supplied individually but supplied in an assembly or a group.

AS : Special part designed to allow interchangeability between new and old part.

CR : Correction

### Section 2 : Items Found In “Remark” Column

Serial Numbers - Where indicated, this indicates a serial number range (inclusive) where a particular part is used.

Model Number - Where indicated, this shows that the corresponding part is utilized only with this specific model number or model number variant.

# or \* : All parts with the same number following # or \* belong to the same assembly. this part cannot be interchanged individually with any other assemblies to replace an old part (indicated by #), with a new part(indicated by \*), then all other parts of that assembly must be replaced with new ones.

Note : If more than one of the same reference number is listed, the last one listed indicates newest(or latest)part available.

### Section 3: Example

REF NO.	PART NO.	PART NAME	QTY	MRK	REMARKS
457(1)	5122-09230	Hinge Metal, Upper/24g	1		-1070 #3 (5)
457(2)	5072-09420	Hinge Metal, Upper M16	1	OX(3)	U1071-(6) * 3(7)

(1) Old part

(2) New part

(3) New part usable with old machine, but old part not usable with new machine (reference section 1).

(4) Old part number is used through this machine serial number.

(5) Old part, used in an assembly with other parts marked with #3. To use this part on a new machine, all other parts in this assembly must be replaced with old ones.

(6) New part put into use starting with this serial number and is still current.

(7) New part used in an assembly with other parts marked \* 3, to use this part as a replacement for an old part, all other \* 3 marked parts must be changed at the same time.

### Section 4: Items Found In “MK2” Column

(only for suspended products)

! OO (“OO” is shown in figure) : The part shown in lower line is supplied.

! SD : Not available due to termination of production.

! NS : Not supplied individually, but supplied in an assembly or a group.

! PD : Supplied as unit product.

SS : Not available after stock run out.

(The contents of this parts catalog are subject to change without notice.)

GX100U-KRBN (FOR MT-65HA EXP)  
 GX100RT-KRBN (FOR MT-65HA EXP)  
 1. CYLINDER BARREL

BVW0

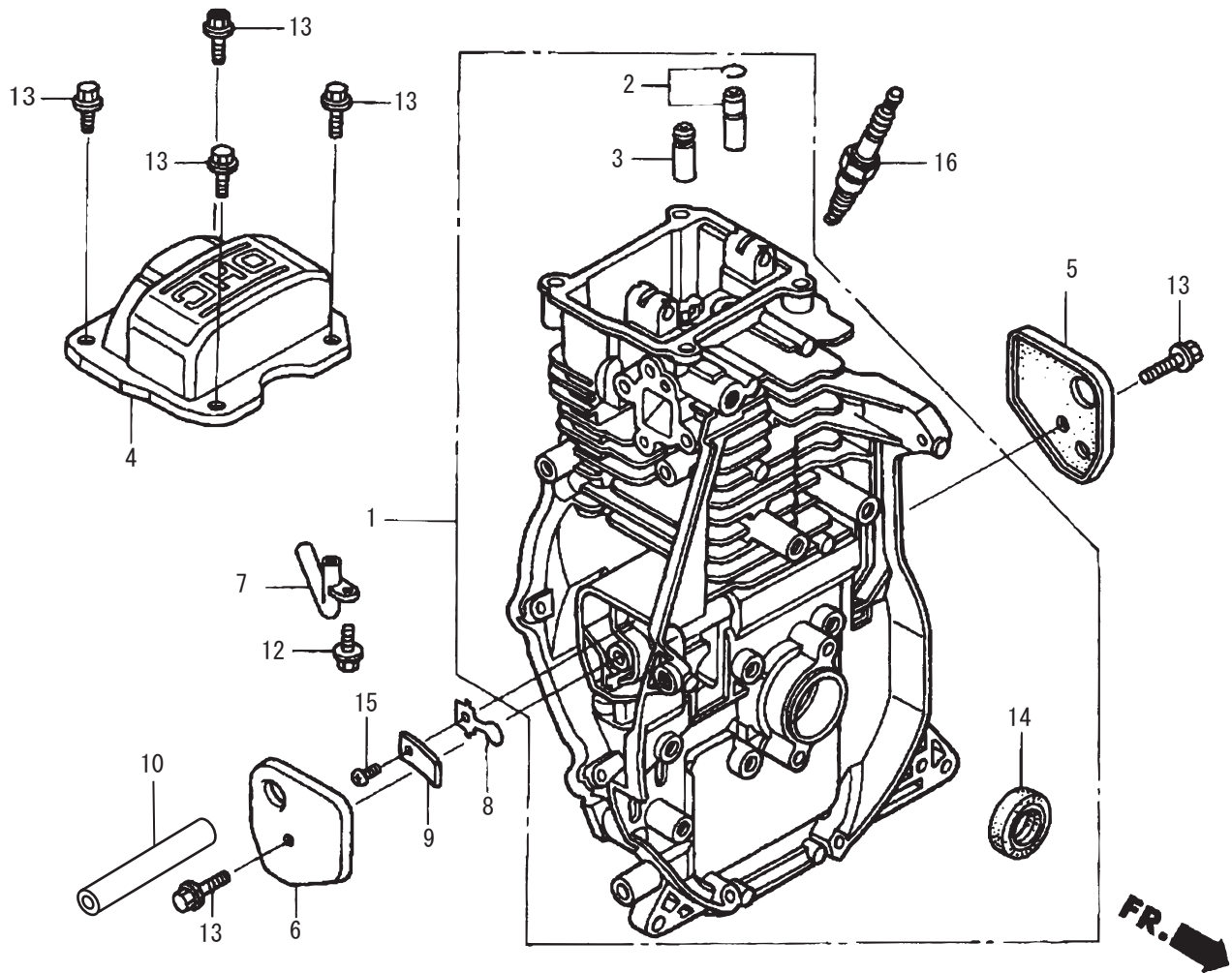

\*\* BVW \*\*

REF NO.	PART NO.	PART NAME	Q' TY	MRK	MK2	REMARKS
1	12000-ZOD-405	BARREL ASS'Y., CYLINDER	1			
2	12201-ZOD-305	GUIDE ASS'Y, EX VALVE (OS)	1			
3	12204-ZOD-305	GUIDE, INLET VALVE (O.S.)	1			
4	12311-ZOD-000	COVER, HEADT	1			
5	12355-ZOD-000	COVER COMP A, BREATHER	1			
6	12365-ZOD-000	COVER COMP B, BREATHER	1			
7	15171-ZOD-V00	PIPE, BREATHER	1			
8	15571-ZOD-V71	VALVE, OIL OUTLET	1			
9	15572-ZM7-000	PLATE, STOPPER	1			
10	15721-ZOD-V00	TUBE, BREATHER	1			
12	90008-ZM7-000	BOLT 4X10	1			
13	90014-952-000	BOLT, FLANGE 6X14 (CT200)	6			
14	91202-KJ9-003	OIL SEAL 20X32X6	1			
15	93500030050A	SCREW 3X5	1			
16	98056-55777	PLUG, SPARK (CR5HSB)	1			

GX100U-KRBN (FOR MT-65HA EXP)  
 GX100RT-KRBN (FOR MT-65HA EXP)  
 2. CRANK CASE COVER

BVX0

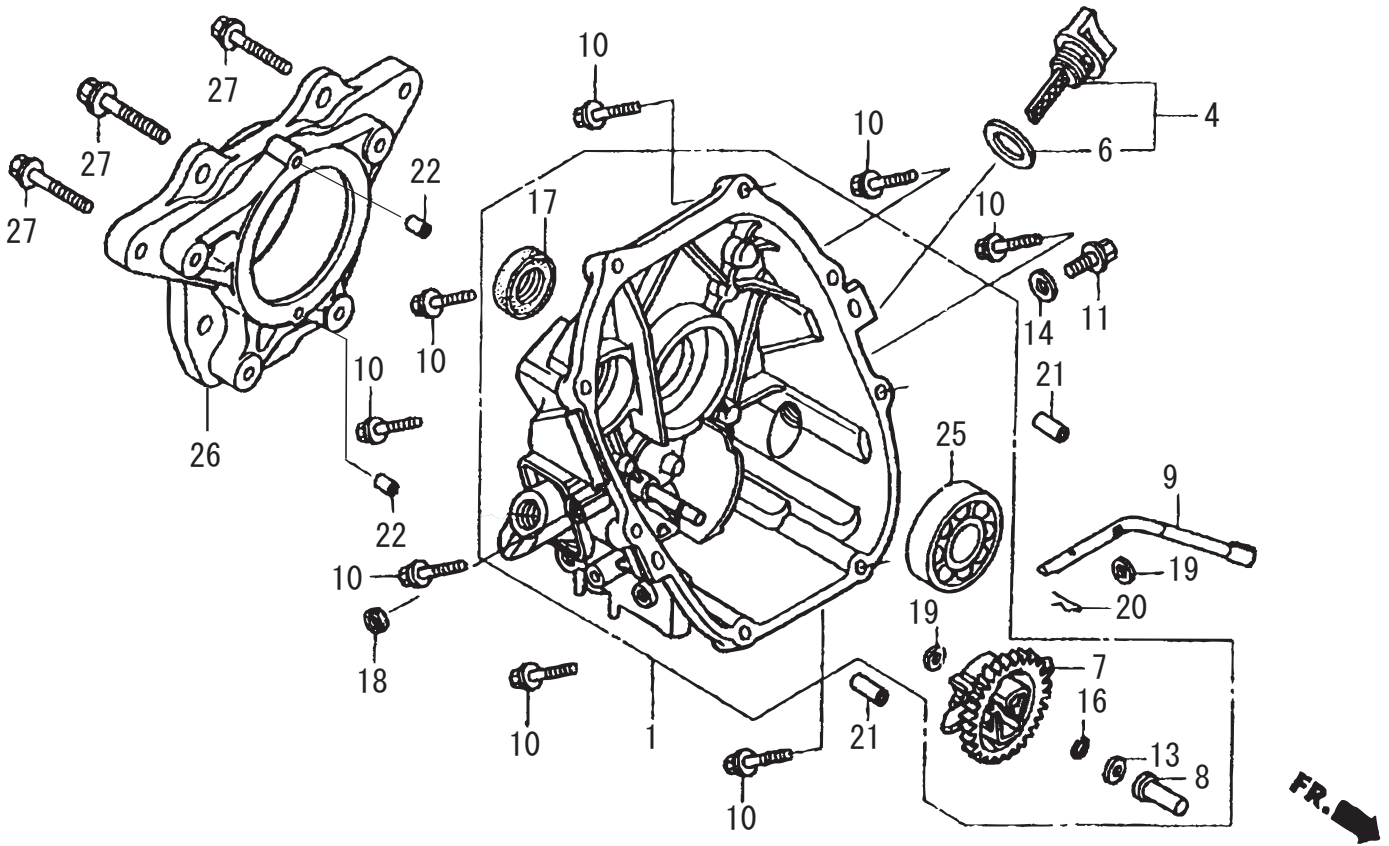

\*\* BVX \*\*

REF NO.	PART NO.	PART NAME	Q' TY	MRK	MK2	REMARKS
1	11300-Z0D-409	COVER ASSY., CRANK CASE	1			
4	15600-ZM7-003	OIL FILLER CAP ASSY	1			GX100U-KRBN
4	15600-ZDF-000	CAP AY, OIL FILLER/GX100RT	1			GX100RT-KRBN
6	15625-ZE1-003	PACKING, OIL FILLER CAP	1			GX100U-KRBN
6	15625-Z0T-800	PACKING, OIL FILLER CAP	1			GX100RT-KRBN
7	16510-ZL8-000	GOVERNOR ASSY.	1			
8	16531-ZE1-000	SLIDER, GOVERNOR	1			
9	16541-Z0D-000	SHAFT, GOVERNOR ARM	1			
10	90121-952-000	FLANGE BOLT 6X25	8			
11	90131-ZE1-000	BOLT, DRAIN PLUG	1			
13	90451-ZE1-000	THRUST WASHER 6MM	1			
14	90601-ZE1-000	WASHER, DRAIN PLUG	1			
16	90602-ZE1-000	CLIP, GOVERNOR HOLDER	1			
17	91202-KJ9-003	OIL SEAL 20X32X6	1			
18	91231-891-003	OIL SEAL 6X11X4	1			
19	94101-06800	PLAIN WASHER 6MM	2			
20	94251-08000	LOCK PIN 8MM	1			
21	94301-08200	KNOCK PIN 8X20	2			
22	94303-06100	DOEL PIN, 6X10	1			
25	96101-Z0D-V01	BEARING, RADIAL BALL	1			
26	11511-Z0D-V10	FLANGE, P. T. O.	1			
27	957010804500	BOLT, FLANGE, 8X45	4			

GX100U-KRBN ( FOR MT-65HA EXP)  
 GX100RT-KRBN ( FOR MT-65HA EXP)  
 3. CRANK SHAFT

BVY0

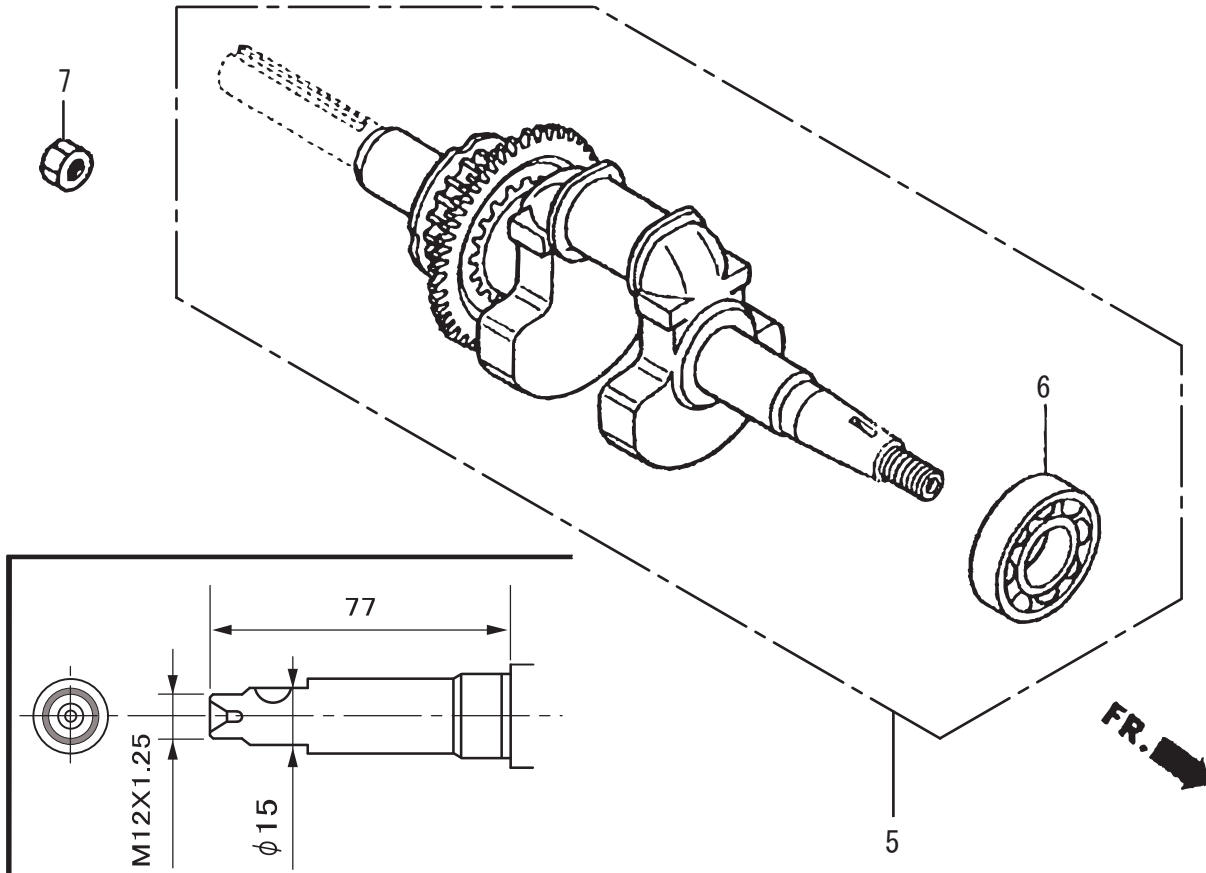

\*\* BVX \*\*

REF NO.	PART NO.	PART NAME	Q' TY	MRK	MK2	REMARKS
5	13310-Z0D-V00	CRANK SHAFT COMP.	1			
6	91001-Z0D-V01	BEARING, RADIAL BALL	1			
7	94002-120000S	NUT, RADIAL BALL, 6204C	1			GX100U-KRBN

GX100U-KRBN ( FOR MT-65HA EXP)  
 GX100RT-KRBN ( FOR MT-65HA EXP)  
 4. PISTON, CONNECTING ROD

BVZ0

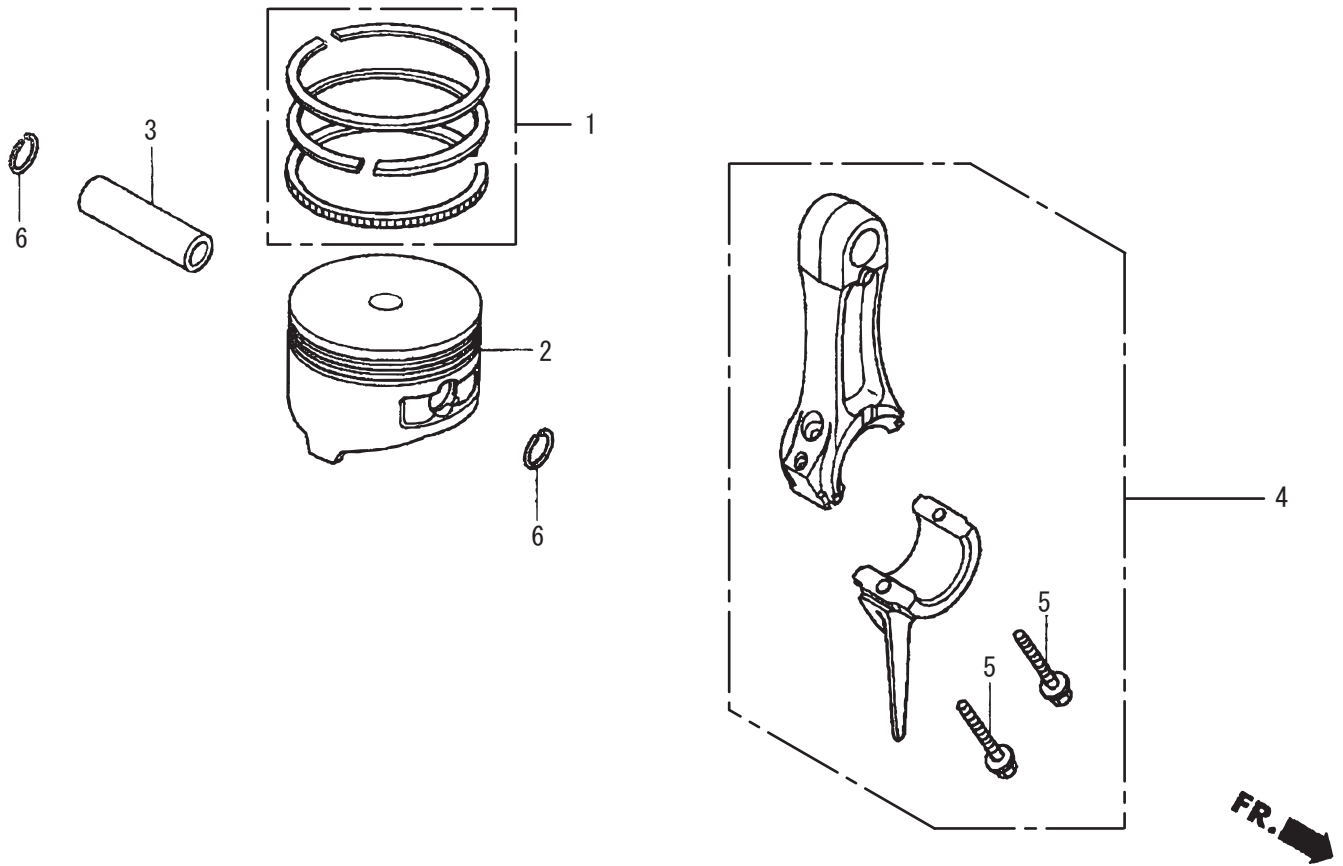

\*\* BVZ \*\*

REF NO.	PART NO.	PART NAME	Q' TY	MRK	MK2	REMARKS
1	13010-Z0D-003	RING SET, PISTON	1			
2	13101-Z0D-000	PISTON	1			
3	13111-ZE0-000	PISTON PIN	1			
4	13200-Z0D-000	CONNECTING ROD ASSY.	1			
4	13200-Z0D-305	CONNECTING ROD AY (UNDER)	1			UNDER SIZE
5	90001-ZM7-000	CONNECTING ROD BOLT	1			
6	90551-ZE0-000	CLIP, PISTON PIN 13MM	1			

GX100U-KRBN ( FOR MT-65HA EXP)  
 GX100RT-KRBN ( FOR MT-65HA EXP)  
 5. CAMSHAFT

BWA0

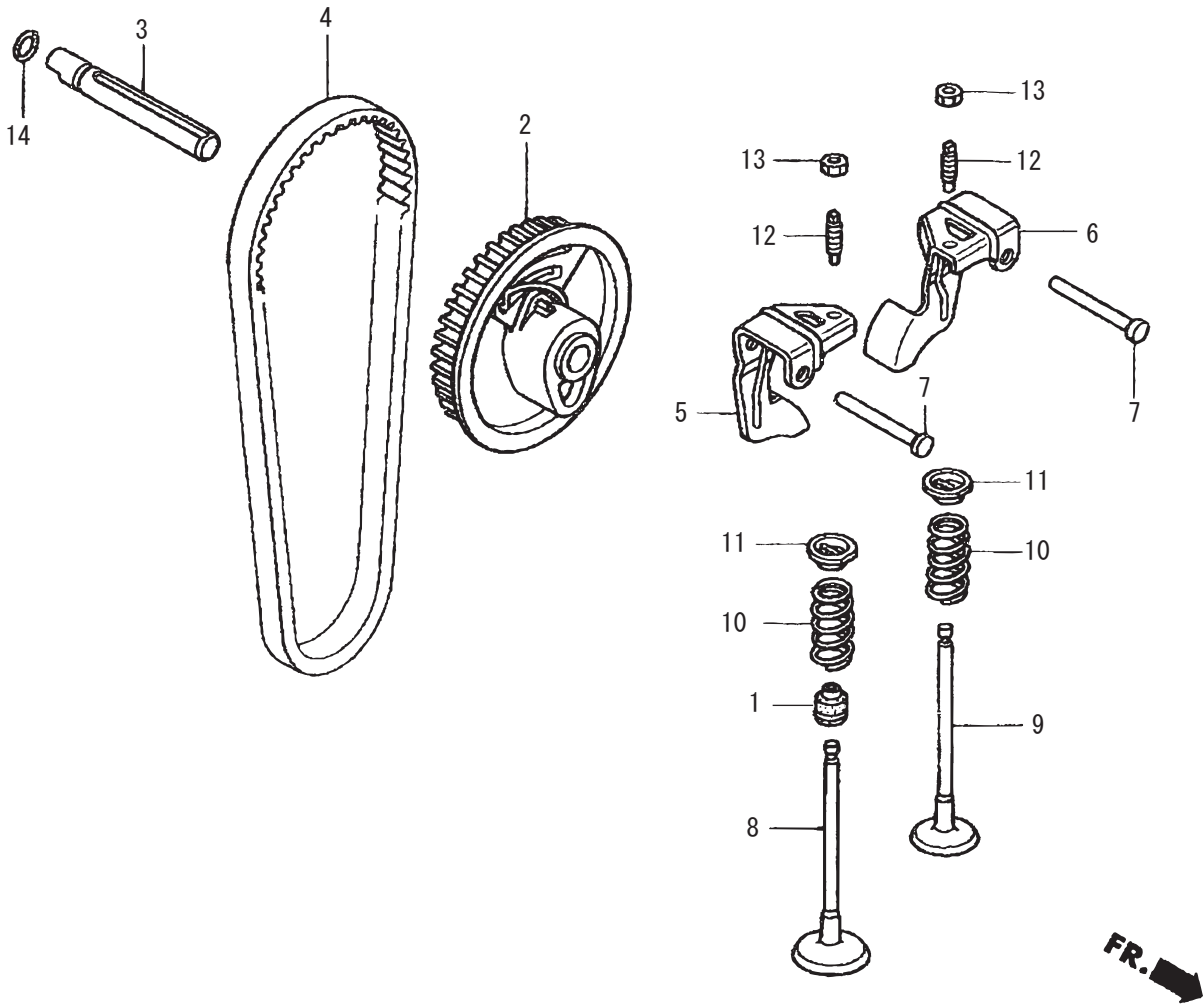

\*\* BWA \*\*

REF NO.	PART NO.	PART NAME	Q' TY	MRK	MK2	REMARKS
1	12209-KT7-013	SEAL, VALVE STEM	1			
2	14320-ZOD-010	PULLEY COMP., CAMSHAFT	1			GX100U-KRBN
2	14320-ZDD-000	PULLEY COMP., CAMSHAFT/RTE	1			GX100RT-KRBN
3	14324-ZOD-000	SHAFT, CAM PULLEY	1			
4	14400-ZOD-003	TIMING BELT (61YU7 G-200)	1			
5	14431-ZDD-000	ROCKER ARM, INTAKE VALVE	1			
6	14441-ZDD-000	ROCKER ARM, EXHAUST VALVE	1			
7	14461-ZL8-000	SHAFT, ROCKER ARM	2			
8	14711-ZOD-000	INLET VALVE	1			
9	14721-ZOD-000	EXHAUST VALVE	1			
10	14751-ZOD-000	SPRING, VALVE	2			
11	14771-ZM3-010	RETAINER, VALVE SPRING	2			
12	90012-333-000	SCREW, . TAPPET ADJUSTING	2			
13	90206-001-000	NUT, . TAPPET ADJUSTING	2			
14	91301-ZM0-V31	O RING 6. 8X1. 9	1			

GX100U-KRBN ( FOR MT-65HA EXP)  
 GX100RT-KRBN ( FOR MT-66HA EXP)  
 6. RECOIL STARTER

BWBO

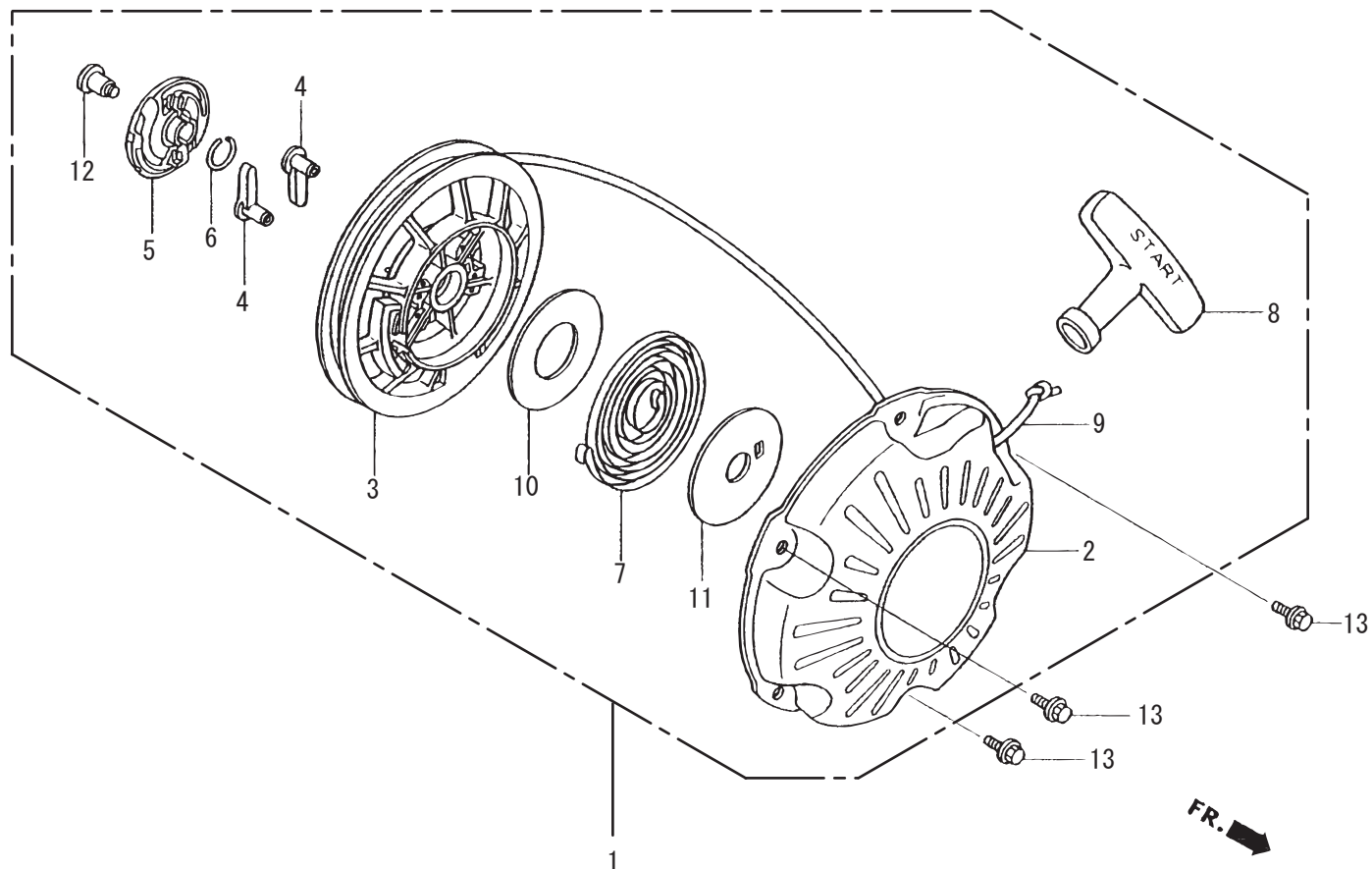

\*\* BWBO \*\*

REF NO.	PART NO.	PART NAME	Q' TY	MRK	MK2	REMARKS
1	28400Z0DV04ZA	RECOIL STARTER AY/GX100	1			
2	28410Z0DV02ZA	CASE COMP/RECOIL *5-3-5(B	1			
3	28421-Z0D-V02	REEL, RECOIL STARTER	1			GX100U-KRBN
3	28421-ZDD-003	REEL, RECOIL STARTER (BLACK)	1			GX100RT-KRBN
4	28422-ZG0-W02	RATCHET, STARTER	2			
5	28433-ZG0-W02	GUIDE, RATCHET	1			
6	28441-ZW6-003	SPRING, FRICTION	1			
7	28442-ZH8-003	SPRING, RECOIL STARTER	1			
8	28461-ZH8-013	KNOB, STARTER	1			GX100U-KRBN
8	28461-ZDD-003	KNOB, RECOIL STARTER	1			GX100RT-KRBN
9	28462-Z0D-V03	ROPE, RECOIL STARTER	1			
10	28467-Z0D-V02	PLATE, SIDE	1			
11	28468-Z0D-V02	PLATE, SLIDE	1			
12	90003-ZH8-003	SET SCREW	1			
13	95701-0600800	FLANGE BOLT 6X8	3			



GX100U-KRBN ( FOR MT-65HA EXP)  
 GX100RT-KRBN ( FOR MT-65HA EXP)  
 7. FAN COVER

BWC0

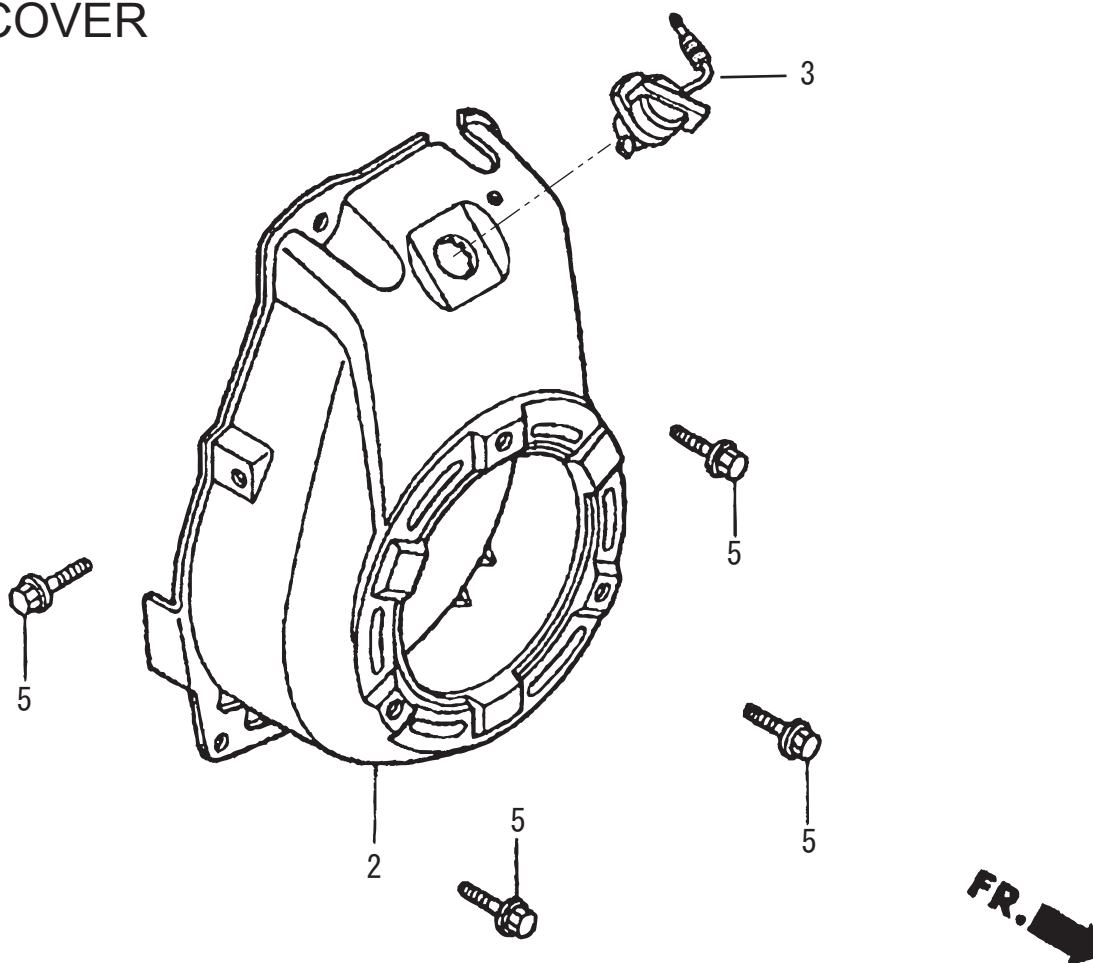

\*\* BWC \*\*

REF NO.	PART NO.	PART NAME	Q' TY	MRK	MK2	REMARKS
2	19610Z0DV00ZB	FAN COVER CP., BL N/GX100	1			
3	35120-Z0D-V81	SWITCH ASSY., ENGINE STOP	1			
5	90014-952-000	BOLT, FLANGE 6X14(CT200)	4			

GX100U-KRBN ( FOR MT-65HA EXP)  
GX100RT-KRBN ( FOR MT-65HA EXP)

BWD0

### 8. CARBURETOR

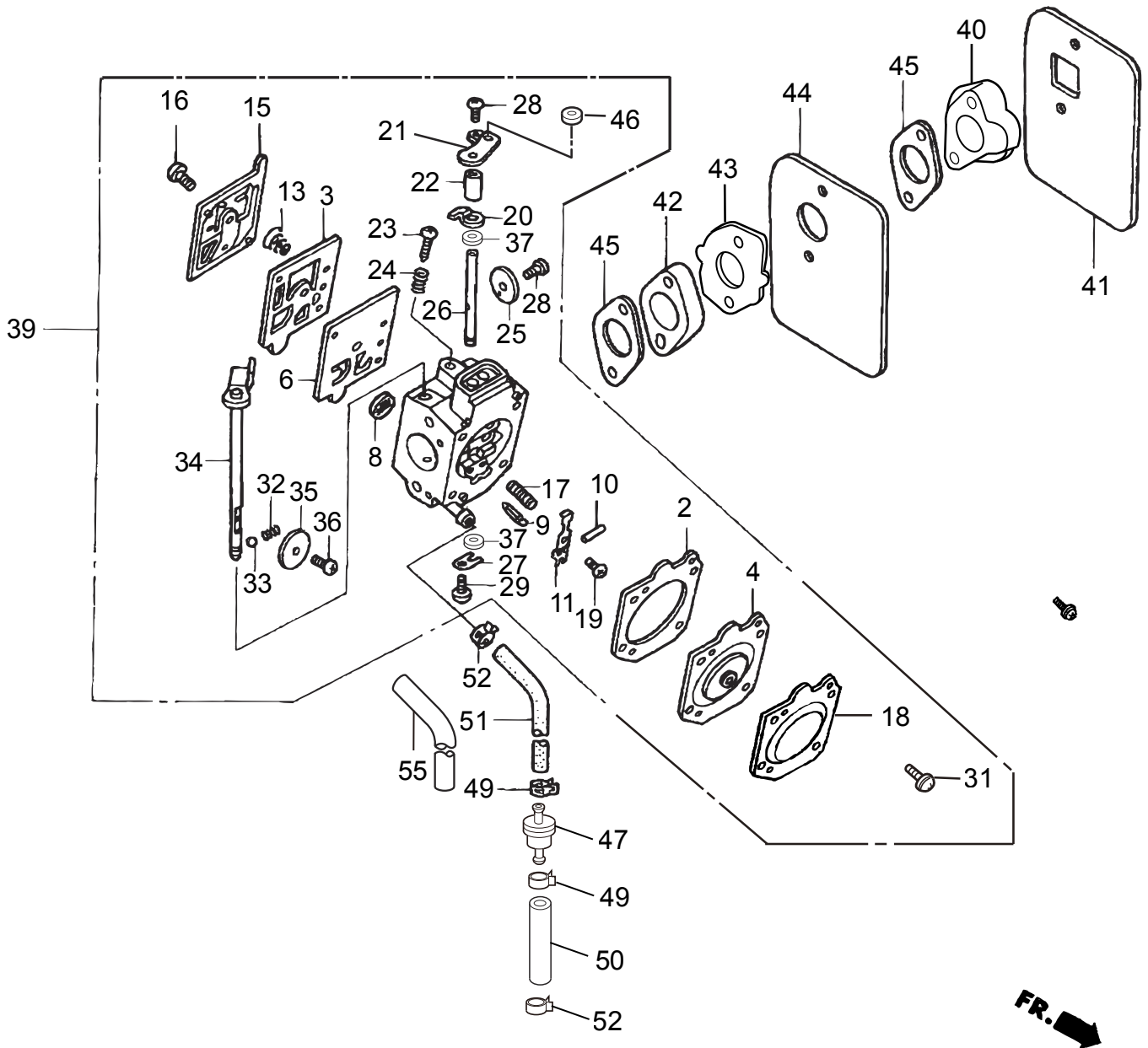

**GX100U-KRBN / GX100RT-KRBN for MT-65HA(EXP)**

2014/7/14

**8. CARBURETOR**

**\*\* BWD \*\***

REF NO.	PART NO.	PART NAME	Q'TY	MRK	MK2	REMARKS
2	16010-ZOD-V02	GASKET, METALING DIAPHRAGM	1			
3	16011-ZOD-V02	GASKET, PUMP	1			
4	16013-ZOD-V02	DIAPHRAGM AY., METALING	1			
6	16014-ZOD-V02	DIAPHRAGM, PUMP	1			
8	16018-ZM3-004	SCREEN, INLET	1			
9	16019-ZM3-004	VALVE, INLET NEEDLE	1			
10	16022-ZM3-014	PIN, METALING LEVER	1			
11	16023-ZOD-V02	LEVER, METALING	1			
13	16030-ZM3-004	SPRING, PUMP	1			
15	16040-Z4E-802	COVER, PUMP	1			
16	16041-ZOD-V02	SCREW	1			
17	16042-Z4E-V92	SPRING	1			
18	16043-ZOD-V02	COVER, METALING DIAPHRAGM	1			
19	16044-Z4E-802	SCREW	1			
20	16045-ZOD-V02	STOPPER, THROTTLE LEVER	1			
21	16046-ZOD-V73	LEVER, THROTTLE/HDA234-	1			
22	16048-ZOD-V02	SPACER, THROTTLE LEVER	1			
23	16049-Z4E-S12	SCREW, IDLE ADJUSTING	1			
24	16050-ZOD-V02	SPRING	1			
25	16051-ZOD-V02	VALVE, THROTTLE	1			
26	16052-ZOD-V02	SHAFT, THROTTLE	1			
27	16053-ZOD-V02	CLIP, THROTTLE SHAFT	1			
28	16054-ZOD-V02	SCREW, VALVE	2			
29	16055-ZOD-V02	SCREW ASSY.	1			
31	16055-ZOD-V02	SCREW ASSY.	4			
32	16056-ZOD-V02	SPRING	1			
33	16057-ZOD-V02	BALL	1			
34	16058-ZOD-V72	SHAFT ASSY, CHOKE	1			
35	16059-ZOD-V03	VALVE, CHOKE	1			
36	16060-ZOD-V02	SCREW	1			
37	16061-ZOD-V02	SEAL, DUST	2			
39	16100-Z4E-S16	CARBURETOR AY/GX100UKRBM	1			
40	16211-ZOD-V01	INSULATOR, CABURETOR	1			
41	16212-ZOD-V00	PACKING, INSULATOR	1			
42	16213-Z4E-S10	INSULATOR, B	1			
43	16214-ZOD-V01	PACKING B, INSULATOR	1			
44	16215-ZOD-V00	PLATE, INSULATOR	1			
45	16221-ZOD-V00	PACKING, CABURETOR	2			
46	16552-896-650	COLLAR. LEVER	1			
47	16910-Z4E-S21	STRAINER, FUEL	1			GX100RT-KRBN
49	90602-Z4E-003	CLAMP, TUBE (D9.4)/RT-KRB	2			GX100RT-KRBN
50	91434-Z4E-812	HOSE FUEL 4.5X80(FKM)	1			GX100RT-KRBN
51	91434-Z4E-812	HOSE FUEL 4.5X80(FKM)	1			GX100U-KRBN
51	91434-Z4E-872	HOSE, FUEL 4.5X270(FKM)RT	1			GX100RT-KRBN
52	95002-4085008	CLAMP, TUBE	2			
55	95003-3602120	TUBE, VINYL 11X13X210	1			

GX100U-KRBN ( FOR MT-65HA EXP)  
 GX100RT-KRBN ( FOR MT-65HA EXP)  
 9. AIR CLEANER

BWE0

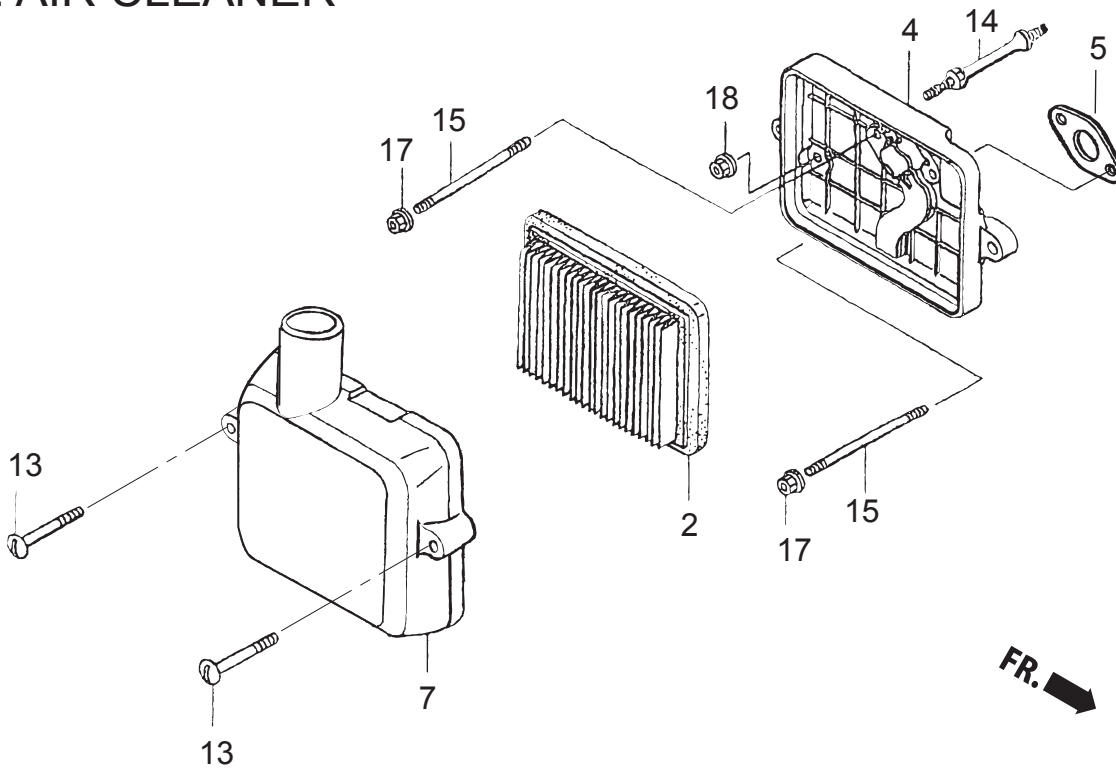

\*\* BWE \*\*

REF NO.	PART NO.	PART NAME	Q' TY	MRK	MK2	REMARKS
2	17211-ZL8-023	CLEANER, ELEMENT/GX100U	1			
4	17220-Z0D-V00	CASE COMP. , AIR CLEANER/HA	1			GX100U-KRBN
4	17220-Z0D-V01	CASE COMP. , AIR CLEANER/HA	1			GX100RT-KRBN
5	17228-Z0D-V01	PACKING, AIR CLEANER/65HA	1			
7	17231-Z0D-V62	COVER, AIR CLEANER/GX100	1			
13	90011-Z0D-000	BOLT, AIR CLEANER COVER	2			
14	90041-Z0D-V00	STUD BOLT /GX100KRBM	1			
15	90042-Z0D-V00	STUD BOLT 5X85 ( CT200 )	2			
17	94050-05000	FLANGE NUT 5MM	2			
18	94050-06000	FLANGE NUT 6MM	1			

GX100U-KRBN ( FOR MT-65HA EXP)  
 GX100RT-KRBN ( FOR MT-65HA EXP)  
 10. MUFFLER

BWF0

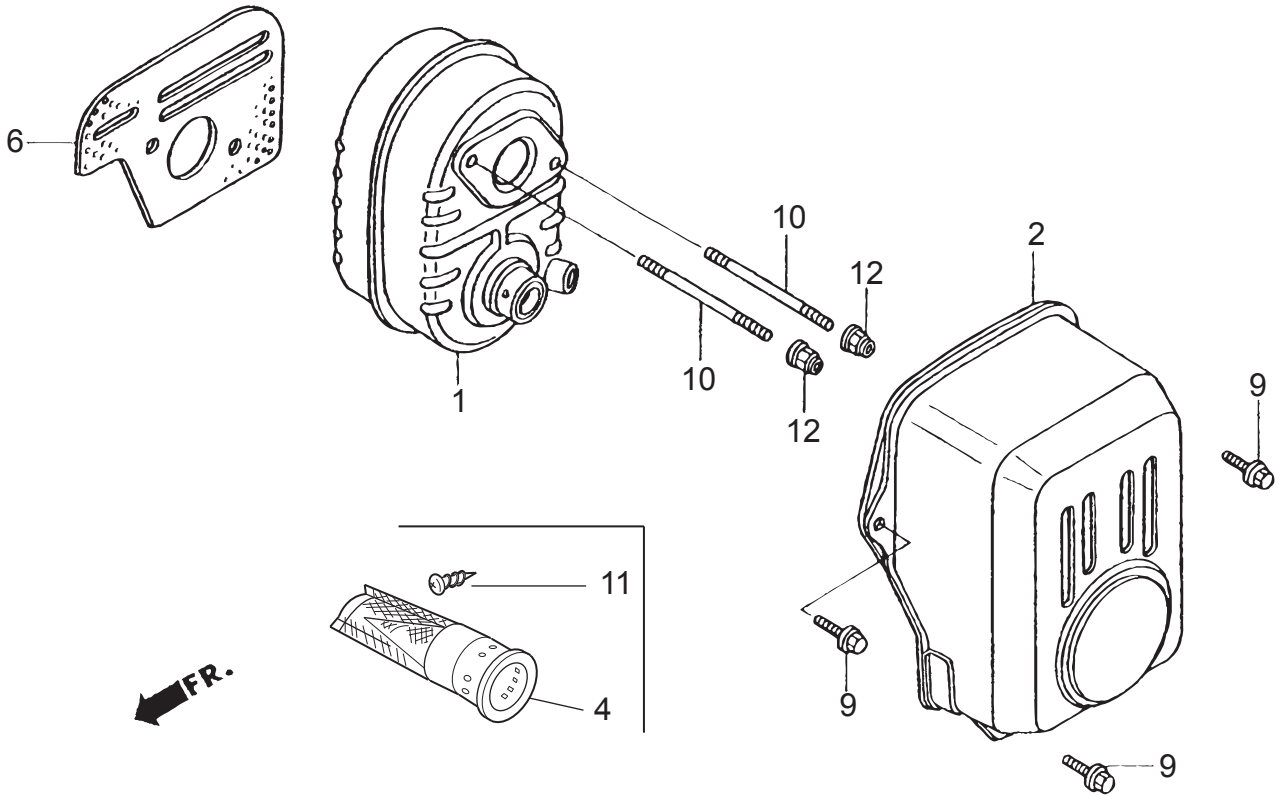

\*\* BWF \*\*

REF NO.	PART NO.	PART NAME	Q' TY	MRK	MK2	REMARKS
1	18310-Z0D-V20	MUFFLER COMP.	1			
2	18321-Z0D-V22	MUFFLER PROTECTOR	1			
4	18350-ZL8-000	ARRESTER COMP. , SPARK/RT-E				SELECT
6	18381-Z0D-000	GASKET, MUFFLER	1			
9	90014-952-000	BOLT, FLANGE 6X14(CT200)	3			
10	90048-Z0D-V00	STUD BOLT 6X78	2			
11	90055-ZE1-000	TAPPING SCREW 4X6				SELECT
12	90343-ZE6-000	NUT, SELF-LOCK 6MM	2			

GX100U-KRBN ( FOR MT-65HA EXP)  
 GX100RT-KRBN ( FOR MT-65HA EXP)  
 11. FLYWHEEL , IGNITION

BWG0

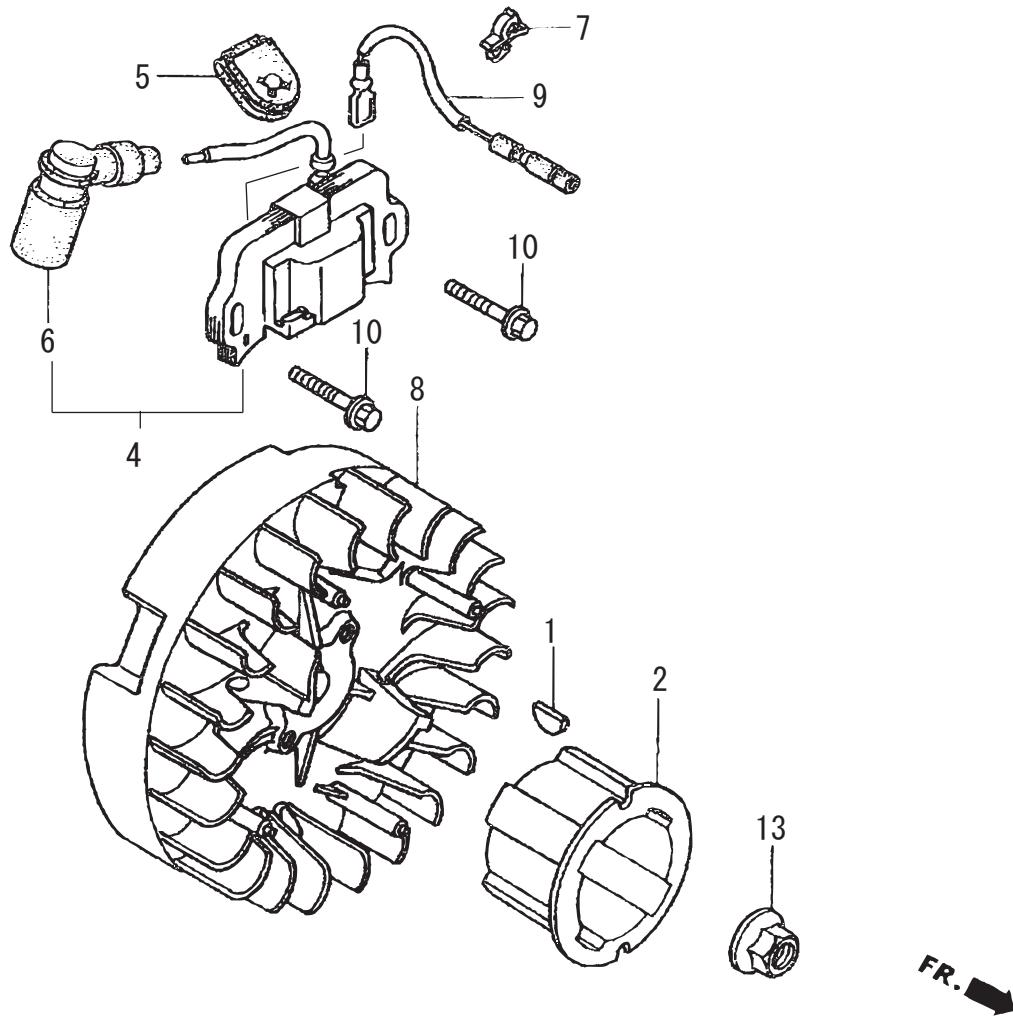

\*\* BWG \*\*

REF NO.	PART NO.	PART NAME	Q' TY	MRK	MK2	REMARKS
1	13331-ZM7-000	WOODRUFF KEY 25X18	1			
2	28451-ZOD-V03	STARTER PULLEY	1			
4	30500-ZOD-V02	IGNITION COIL ASSY/GX100	1			
5	30564-ZA5-000	GROMMET, CORD	1			
6	30700-ZOD-V01	TERMINAL ASS'Y	1			
7	30701-883-000	CLIP, HIGH TENSION CORD	1			
8	31110-ZOD-003	FLYWHEEL COMP.	1			
9	32195-ZOD-000	CORD, STOP SWITCH	1			
10	90022-888-010	FLANGE BOLT 6X20	2			
13	94050-12000	FLANGE NUT M12	1			

GX100U-KRBN ( FOR MT-65HA EXP)  
 GX100RT-KRBN ( FOR MT-65HA EXP)  
 12. CONTROL

BWH0

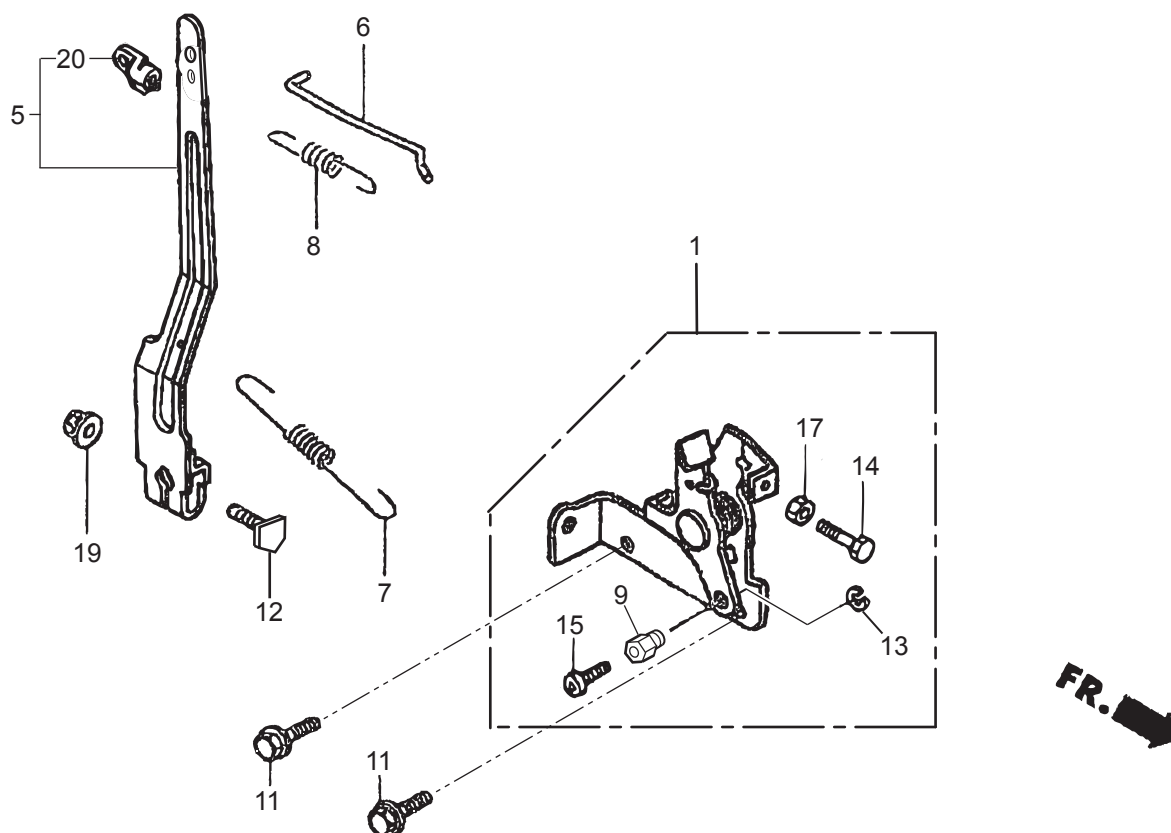

\*\* BWH \*\*

REF NO.	NO.	PART NO.	PART NAME	Q' TY	MRK	MK2	REMARKS
	1	16500-Z0D-V50	CONTROL ASSY /GX100 KRB1	1			
	5	16550-Z0D-V01	ARM COMP., GOVERNOR / KRBM	1			
	6	16555-Z0D-V00	ROD, GOVERNOR / GX100KRBM	1			
	7	16561-Z0D-V00	SPRING, GOVERNOR/GX100KRBM	1			
	8	16562-Z0D-V00	SPRING, THROTTLE RETURN	1			
	9	16594-883-010	HOLDER, WIRE	1			
	11	90014-952-000	BOLT, FLANGE 6X14(CT200)	2			
	12	90015-ZE5-010	BOLT, GOVERNOR ARM	1			GX100U-KRBN
	12	90015-Z5T-000	BOLT, GOVERNOR ARM	1			GX100RT-KRBN
	13	90605-230-000	CIR CLIP	1			
	14	92301-050200A	BOLT 5X20	1			
	15	93500040060H	SCREW 4X6	1			
	17	94001-050000S	NUT M5	1			
	18	94050-06000	FLANGE NUT 6MM	1			
	20	16263-883-W10	JOINT, ROD	1			GX100RT-KRBN

GX100U-KRBN ( FOR MT-65HA EXP)  
 GX100RT-KRBN ( FOR MT-65HA EXP)  
 13. LABEL ,TOOL

BWI0

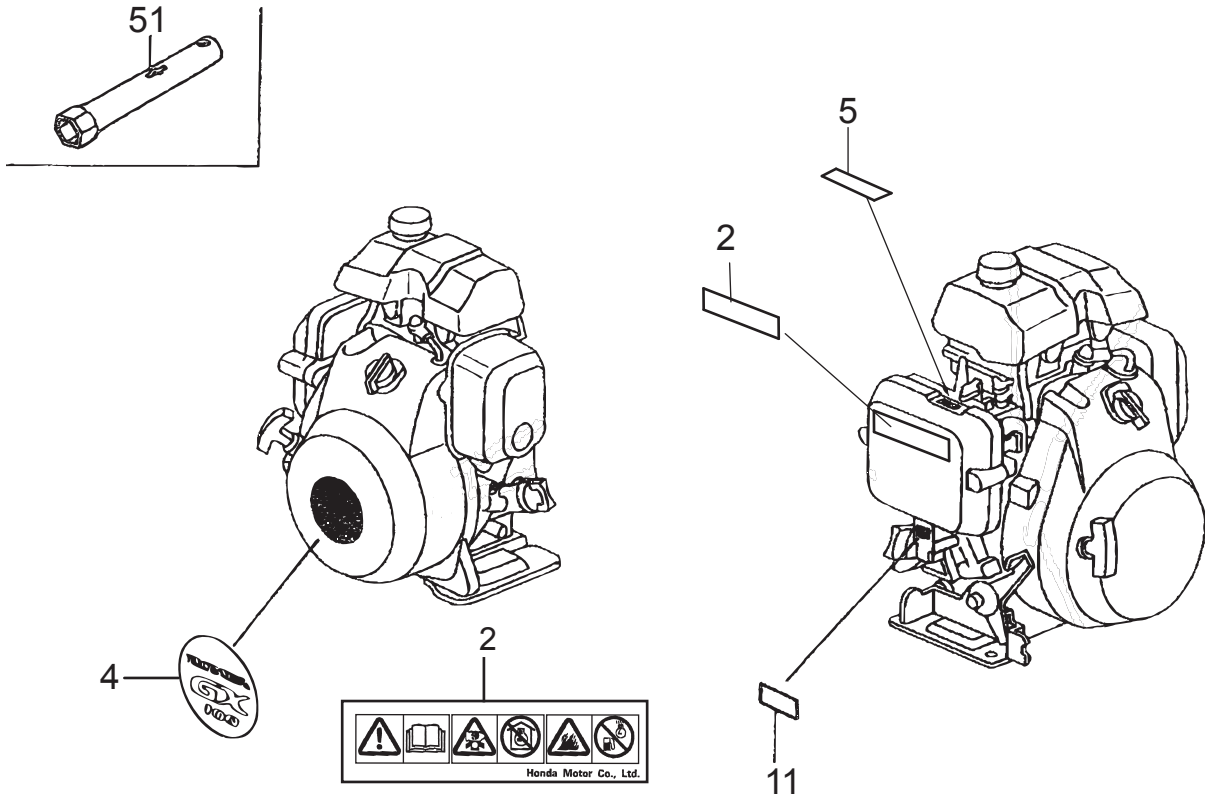

\*\* BWI \*\*

REF	NO.	PART NO.	PART NAME	Q' TY	MRK	MK2	REMARKS
2		87519-Z0J-000	MARK, OPERATOR CAUTION	1			GX100U-KRBN
2		87519-ZDD-000	MARK, OPERATOR CAUTION/RT	1			GX100RT-KRBN
4		87521-Z0D-V02	EMBLEM ( RAMMA ) ( GX100 )	1			GX100U-KRBN
4		87521-ZDD-P10	EMBLEM ( GX100 ) (RAMMER)	1			GX100RT-KRBN
5		87528-Z0D-000	MARK, CHOKE INDICATION	1			
11		87601-Z4E-R60	MARK, TYPE (KRBN)	1			
51		89216-130-690	WRENCH, SPARK PLUG	1			GX100U-KRBN
51		89216-045-670	WRENCH, PLUG/GX100RT-KRBE	1			GX100RT-KRBN





# Note

---

A series of horizontal dashed lines for writing notes.





**MIKASA SANGYO CO., LTD.**

HEAD OFFICE

No.4-3, Sarugakucho 1-chome,  
Chiyoda-ku, Tokyo, 101-0064,  
Japan

<http://www.mikasas.com>