



OPERATING INSTRUCTIONS

MQ WHITEMAN RIDE-ON POWER TROWEL JWN24HTCSL, JWN24HSCSL



U.S. Revision #4 (04/22/22)
AUS Version 2.0 (October 2024)

FOR MORE INFORMATION
CONTACT US ON 1300 353 986 OR VISIT flextool.com.au

EXCLUSIVE TO



OPERATION MANUAL



***WHITEMAN* SERIES** **MODELS**

JWN24HTCSL

JWN24HSCSL

RIDE-ON POWER TROWELS
(HONDA GX690RTAF GASOLINE ENGINE)

STARTING S/N VB0206952

Revision #4 (04/22/22)

To find the latest revision of this publication or
associated parts manual, visit our website at:
www.multiquip.com



THIS MANUAL MUST ACCOMPANY THE EQUIPMENT AT ALL TIMES.

PN: 23624

PROPOSITION 65 WARNING



SILICOSIS/RESPIRATORY WARNINGS

! WARNING



SILICOSIS WARNING

Grinding/cutting/drilling of masonry, concrete, metal and other materials with silica in their composition may give off dust or mists containing crystalline silica. Silica is a basic component of sand, quartz, brick clay, granite and numerous other minerals and rocks. Repeated and/or substantial inhalation of airborne crystalline silica can cause serious or fatal respiratory diseases, including silicosis. In addition, California and some other authorities have listed respirable crystalline silica as a substance known to cause cancer. When cutting such materials, always follow the respiratory precautions mentioned above.

! WARNING



RESPIRATORY HAZARDS

Grinding/cutting/drilling of masonry, concrete, metal and other materials can generate dust, mists and fumes containing chemicals known to cause serious or fatal injury or illness, such as respiratory disease, cancer, birth defects or other reproductive harm. If you are unfamiliar with the risks associated with the particular process and/or material being cut or the composition of the tool being used, review the material safety data sheet and/or consult your employer, the material manufacturer/supplier, governmental agencies such as OSHA and NIOSH and other sources on hazardous materials. California and some other authorities, for instance, have published lists of substances known to cause cancer, reproductive toxicity, or other harmful effects.

Control dust, mist and fumes at the source where possible. In this regard use good work practices and follow the recommendations of the manufacturers or suppliers, OSHA/NIOSH, and occupational and trade associations. Water should be used for dust suppression when wet cutting is feasible. When the hazards from inhalation of dust, mists and fumes cannot be eliminated, the operator and any bystanders should always wear a respirator approved by NIOSH/MSHA for the materials being used.

JWN Series Ride-On Trowel

Proposition 65 Warning	2
Silicosis/Respiratory Warnings	3
Table of Contents.....	4
Training Checklist	6
Daily Pre-Operation Checklist	7
Safety Information	8–14
Lifting and Transporting	15–17
Specifications	18
Dimensions.....	19
General Information.....	20
Components	21–23
Setup	24
Inspection	25–26
Operation.....	27–29
Maintenance	30–43
Wiring Diagram.....	44–45
Wiring Diagram Component Locator	46
Troubleshooting	47–50

NOTICE

Specifications are subject to change without notice.

TRAINING CHECKLIST

Training Checklist			
No,	Description	OK?	Date
1	Read operation manual completely.		
2	Machine layout, location of components, checking of engine oil levels.		
3	Fuel system, refueling procedure.		
4	Operation of spray and lights.		
5	Operation of controls (machine not running).		
6	Safety controls, safety stop switch operation.		
7	Emergency stop procedures.		
8	Startup of machine, pre-heat, engine choke.		
9	Maintaining a hover.		
10	Maneuvering.		
11	Pitching.		
12	Matching blade pitch. Twin-Pitch™		
13	Concrete finishing techniques.		
14	Shutdown of machine.		
15	Lifting of machine (lift loops).		
16	Machine transport and storage.		

DAILY PRE-OPERATION CHECKLIST

Daily Pre-Operation Checklist		✓	✓	✓	✓	✓	✓
1	Engine oil level						
2	Condition of blades						
3	Blade pitch operation						
4	Safety stop switch operation						
5	Steering control operation						

SAFETY INFORMATION

Do not operate or service the equipment before reading the entire manual. Safety precautions should be followed at all times when operating this equipment. Failure to read and understand the safety messages and operating instructions could result in injury to yourself and others.



SAFETY MESSAGES

The four safety messages shown below will inform you about potential hazards that could injure you or others. The safety messages specifically address the level of exposure to the operator and are preceded by one of four words: **DANGER**, **WARNING**, **CAUTION** or **NOTICE**.

SAFETY SYMBOLS

! DANGER

Indicates a hazardous situation which, if not avoided, **WILL** result in **DEATH** or **SERIOUS INJURY**.

! WARNING

Indicates a hazardous situation which, if not avoided, **COULD** result in **DEATH** or **SERIOUS INJURY**.





! CAUTION

Indicates a hazardous situation which, if not avoided, **COULD** result in **MINOR** or **MODERATE INJURY**.

NOTICE

Addresses practices not related to personal injury.

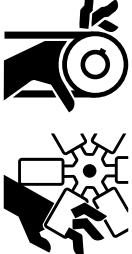
Potential hazards associated with the operation of this equipment will be referenced with hazard symbols which may appear throughout this manual in conjunction with safety messages.







Symbol	Safety Hazard
	Lethal exhaust gas hazards
	Explosive fuel hazards
	Burn hazards
	Rotating parts hazards
	Pressurized fluid hazards
	Hydraulic fluid hazards

SAFETY INFORMATION

SAFETY DECALS

Decals associated with the safe operation of this equipment are defined below.

DECAL	DEFINITION
	<p>DANGER Flying Objects Hazard DO NOT disassemble spring cylinders without qualified service personnel. Possibility exists of severe bodily harm and injury.</p>
	<p>DANGER No Water Warning DO NOT add water to the retardant tank.</p>
	<p>DANGER Belt Guard Hazard DO NOT remove belt guards. Keep hands and fingers clear from engine belts. Moving parts can crush.</p>
	<p>DANGER Training This machine to be operated by qualified personnel only. Ask for training as needed.</p>
	<p>DANGER Inhalation Hazard DO NOT use this equipment in an enclosed area. The engine used with this equipment emits harmful levels of carbon monoxide which can cause severe bodily harm — even death!</p>
	<p>DANGER Rotating Blade Hazard Keep hands, fingers, and feet clear of engine fan blades and guard rings. Moving parts can cut. DO NOT remove guards. Stop engine before servicing.</p>

DECAL	DEFINITION
	<p>WARNING Lifting/Crush Hazard NEVER allow any person to stand underneath the trowel while lifting. DO NOT lift trowel with pans attached. ALWAYS make sure handle is securely attached.</p>
	<p>CAUTION Burn Hazard HOT PARTS can burn skin. DO NOT touch hot parts. Allow machine sufficient amount of time to cool before performing maintenance.</p>
	<p>NOTICE Read Manual To avoid injury, you must read and understand the operator's manual before using this machine.</p>
	<p>NOTICE Protective Clothing ALWAYS wear appropriate clothing when operating the trowel.</p>
	<p>NOTICE Lifting Location Attach a suitable lifting device here to lift the unit.</p>
	<p>UNLEADED GASOLINE The engine used in this equipment runs on unleaded gasoline.</p>

SAFETY INFORMATION

GENERAL SAFETY

CAUTION

- **NEVER** operate this equipment without proper protective clothing, shatterproof glasses, respiratory protection, hearing protection, steel-toed boots and other protective devices required by the job or city and state regulations.



- Avoid wearing jewelry or loose fitting clothes that may snag on the controls or moving parts as this can cause serious injury.
- **NEVER** operate this equipment when not feeling well due to fatigue, illness or when under medication. 
- **NEVER** operate this equipment under the influence of drugs or alcohol.



- **ALWAYS** clear the work area of any debris, tools, etc. that would constitute a hazard while the equipment is in operation.
- No one other than the operator is to be in the working area when the equipment is in operation.
- **DO NOT** use the equipment for any purpose other than its intended purposes or applications.

NOTICE

- This equipment should only be operated by trained and qualified personnel 18 years of age and older.
- Whenever necessary, replace nameplate, operation and safety decals when they become difficult read.
- Manufacturer does not assume responsibility for any accident due to equipment modifications. Unauthorized equipment modification will void all warranties.
- **NEVER** use accessories or attachments that are not recommended by Multiquip for this equipment. Damage to the equipment and/or injury to user may result.
- **ALWAYS** know the location of the nearest **fire extinguisher**. 
- **ALWAYS** know the location of the nearest **first aid kit**. 
- **ALWAYS** know the location of the nearest phone or **keep a phone on the job site**. Also, know the phone numbers of the nearest **ambulance, doctor** and **fire department**. This information will be invaluable in the case of an emergency.

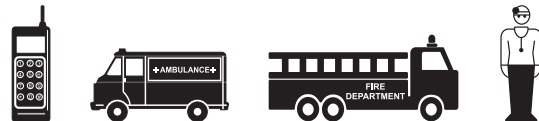

SAFETY INFORMATION

TROWEL SAFETY

DANGER

- Engine fuel exhaust gases contain poisonous carbon monoxide. This gas is colorless and odorless, and can cause death if inhaled.
- The engine of this equipment requires an adequate free flow of cooling air. **NEVER** operate this equipment in any enclosed or narrow area where free flow of the air is restricted. If the air flow is restricted it will cause injury to people and property and serious damage to the equipment or engine.



- **NEVER** operate the equipment in an explosive atmosphere or near combustible materials. An explosion or fire could result causing severe **bodily harm or even death.**



WARNING

- If applicable, **NEVER** use your hand to find hydraulic leaks. Use a piece of wood or cardboard. Hydraulic fluid injected into the skin must be treated by a knowledgeable physician immediately or severe injury or death can occur.
- **ALWAYS** keep clear of rotating or moving parts while operating the trowel.
- **NEVER** disconnect any **emergency or safety devices.** These devices are intended for operator safety. Disconnection of these devices can cause severe injury, bodily harm or even death. Disconnection of any of these devices will void all warranties.



CAUTION

- **NEVER** allow passengers or riders on the trowel during operation.
- **NEVER** lubricate components or attempt service on a running machine.
- **NEVER** place your feet or hands inside the guard rings while starting or operating this equipment.

NOTICE

- **ALWAYS** keep the machine in proper running condition.
- Fix damage to machine and replace any broken parts immediately.
- **ALWAYS** store equipment properly when it is not being used. Equipment should be stored in a clean, dry location out of the reach of children and unauthorized personnel.
- A safety manual for operating and maintenance personnel of concrete power trowels produced by the Association of Equipment Manufacturers (AEM) can be obtained for a fee by ordering through their website at www.aem.org.

Order FORM PT-160

ENGINE SAFETY

WARNING

- **DO NOT** place hands or fingers inside engine compartment when engine is running.
- **NEVER** operate the engine with heat shields or guards removed.
- Keep fingers, hands hair and clothing away from all moving parts to prevent injury.
- **DO NOT** remove the engine oil drain plug while the engine is hot. Hot oil will gush out of the oil tank and severely scald any persons in the general area of the trowel.



CAUTION

- **NEVER** touch the hot exhaust manifold, muffler or cylinder. Allow these parts to cool before servicing equipment.



NOTICE

- **NEVER** run engine without an air filter or with a dirty air filter. Severe engine damage may occur. Service air filter frequently to prevent engine malfunction.
- **NEVER** tamper with the factory settings of the engine or engine governor. Damage to the engine or equipment can result if operating in speed ranges above the maximum allowable.



SAFETY INFORMATION

FUEL SAFETY

DANGER

- **DO NOT** start the engine near spilled fuel or combustible fluids. Fuel is extremely flammable and its vapors can cause an explosion if ignited.
- **ALWAYS** refuel in a well-ventilated area, away from sparks and open flames.
- **ALWAYS** use extreme caution when working with **flammable** liquids.
- **DO NOT** fill the fuel tank while the engine is running or hot.
- **DO NOT** overfill tank, since spilled fuel could ignite if it comes into contact with hot engine parts or sparks from the ignition system.
- Store fuel in appropriate containers, in well-ventilated areas and away from sparks and flames.
- **NEVER** use fuel as a cleaning agent.
- **DO NOT** smoke around or near the equipment. Fire or explosion could result from fuel vapors or if fuel is spilled on a hot engine.



BATTERY SAFETY

DANGER

- **DO NOT** drop the battery. There is a possibility that the battery will explode.
- **DO NOT** expose the battery to open flames, sparks, cigarettes, etc. The battery contains combustible gases and liquids. If these gases and liquids come into contact with a flame or spark, an explosion could occur.



WARNING

- **ALWAYS** wear safety glasses when handling the battery to avoid eye irritation. The battery contains acids that can cause injury to the eyes and skin.
- Use well-insulated gloves when picking up the battery.
- **ALWAYS** keep the battery charged. If the battery is not charged, combustible gas will build up.
- **DO NOT** charge battery if frozen. Battery can explode. When frozen, warm the battery to at least 61°F (16°C).
- **ALWAYS** recharge the battery in a well-ventilated environment to avoid the risk of a dangerous concentration of combustible gases.
- If the battery liquid (dilute sulfuric acid) comes into contact with **clothing or skin**, rinse skin or clothing immediately with plenty of water.
- If the battery liquid (dilute sulfuric acid) comes into contact with **eyes**, rinse eyes immediately with plenty of water and contact the nearest doctor or hospital to seek medical attention.



CAUTION

- **ALWAYS** disconnect the **NEGATIVE** battery terminal before performing service on the equipment.
- **ALWAYS** keep battery cables in good working condition. Repair or replace all worn cables.

TRANSPORTING SAFETY

CAUTION

- **NEVER** allow any person or animal to stand underneath the equipment while lifting.
- Ride-on trowels are very heavy and awkward to move around. Use proper heavy lifting procedures and **DO NOT** attempt to lift the trowel by the guard rings.



NOTICE

- The easiest way to lift the trowel is to utilize the lift loops that are welded to the frame. These lift loops are located to the left and right sides of the operator's seat.

A strap or chain can be attached to these lift loops, allowing a forklift or crane to lift the trowel up onto and off of a slab of concrete. The strap or chain should have a minimum of 2,000 pounds (1,000 kg) lifting capacity and the lifting gear must be capable of lifting at least this amount.

- **NEVER** transport trowel with float pans attached unless safety catches are used and are specifically cleared for such transport by the manufacturer.
- **NEVER** hoist the trowel more than three feet off the ground with float pans attached.
- Before lifting, make sure that the lift loops are not damaged.
- Always make sure crane or lifting device has been properly secured to the lift loops of the equipment.
- **ALWAYS** shutdown engine before transporting.
- **NEVER** lift the equipment while the engine is running.
- Tighten fuel tank cap securely and close fuel cock to prevent fuel from spilling.
- Use adequate lifting cable (wire or rope) of sufficient strength.
- **DO NOT** lift machine to unnecessary heights.
- **ALWAYS** tie down equipment during transport by securing the equipment with rope.

TOWING SAFETY

CAUTION

- Check with your local county or state safety towing regulations, in addition to meeting **Department of Transportation (DOT) Safety Towing Regulations**, before towing your trowel. 
- In order to reduce the possibility of an accident while transporting the trowel on public roads, **ALWAYS** make sure the trailer that supports the trowel and the towing vehicle are mechanically sound and in good operating condition.
- **ALWAYS** shutdown engine before transporting
- Make sure the hitch and coupling of the towing vehicle are rated equal to, or greater than the trailer "gross vehicle weight rating."
- **ALWAYS** inspect the hitch and coupling for wear. **NEVER** tow a trailer with defective hitches, couplings, chains, etc.
- Check the tire air pressure on both towing vehicle and trailer. **Trailer tires should be inflated to 50 psi cold.** Also check the tire tread wear on both vehicles.
- **ALWAYS** make sure the trailer is equipped with a **safety chain**.
- **ALWAYS** properly attach trailer's safety chains to towing vehicle.
- **ALWAYS** make sure the vehicle and trailer directional, backup, brake and trailer lights are connected and working properly.
- DOT Requirements include the following:
 - Connect and test electric brake operation.
 - Secure portable power cables in cable tray with tie wraps.
- The maximum speed for highway towing is 55 MPH unless posted otherwise. Recommended off-road towing is not to exceed 15 MPH or less depending on type of terrain.
- Avoid sudden stops and starts. This can cause skidding, or jack-knifing. Smooth, gradual starts and stops will improve towing.
- Avoid sharp turns to prevent rolling.

SAFETY INFORMATION

- Trailer should be adjusted to a level position at all times when towing.
- Raise and lock trailer wheel stand in up position when towing.
- Place **chock blocks** underneath wheel to prevent rolling while parked.
- Place support blocks underneath the trailer's bumper to prevent tipping while parked.
- Use the trailer's swivel jack to adjust the trailer height to a level position while parked.

ENVIRONMENTAL SAFETY

NOTICE

- Dispose of hazardous waste properly. Examples of potentially hazardous waste are used motor oil, fuel and fuel filters. 
- **DO NOT** use food or plastic containers to dispose of hazardous waste.
- **DO NOT** pour waste, oil or fuel directly onto the ground, down a drain or into any water source.

EMISSIONS INFORMATION

NOTICE

The gasoline engine used in this equipment has been designed to reduce harmful levels of carbon monoxide (CO), hydrocarbons (HC) and nitrogen oxides (NOx) contained in gasoline exhaust emissions.

This engine has been certified to meet US EPA evaporative emissions requirements in the installed configuration.

Attempting to modify or make adjustments to the engine emission system by unauthorized personnel without proper training could damage the equipment or create an unsafe condition.

Additionally, modifying the fuel system may adversely affect evaporative emissions, resulting in fines or other penalties.

Emission Control Label

The emission control label is an integral part of the emission system and is strictly controlled by regulation(s).

The label must remain with the engine for its entire life.

If a replacement emission label is needed, please contact your authorized Honda Engine Distributor.

LIFTING AND TRANSPORTING

WORK SAFELY!

WARNING



Failure to comply with these lifting instructions may result in **slings failure** and **severe personal injury or death**.

Only **qualified personnel** with proper training should perform this procedure. Follow all rigging and lifting safety rules when performing this procedure.

LIFTING SAFETY

CAUTION

- **NEVER** allow any person to stand underneath the equipment while lifting.
- Ride-on trowels are very heavy and awkward to move around. Use proper heavy lifting procedures and **DO NOT** attempt to lift the trowel by the guard rings.
- **NEVER** lift the trowel with the operator on the machine.

NOTICE

- **NEVER** hoist the trowel more than three feet off of the ground with float pans attached.
- Before lifting, make sure that the lift loops are not damaged.
- **ALWAYS** make sure any lifting device has been properly secured to the lift loops of the trowel.
- **DO NOT** lift the trowel to unnecessary heights.
- **ALWAYS** shut down the engine before transporting.
- **NEVER** lift the trowel while the engine is running.
- Tighten the fuel tank cap securely and close the fuel cock to prevent fuel from spilling.

SLING INSPECTION

Inspect the lifting slings provided with your trowel (Figure 1) **before each use**. If replacement slings are needed, refer to the parts manual included with your trowel for part numbers, and order from your Multiquip parts dealer or importer.

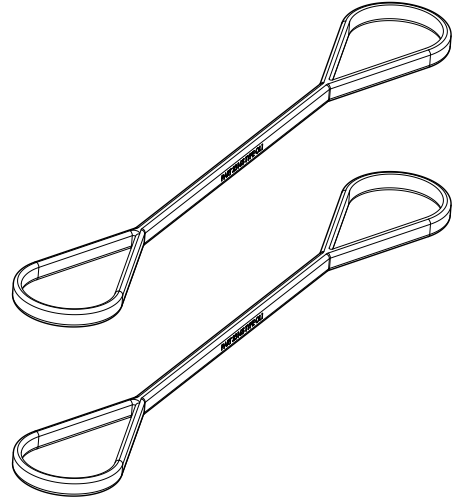
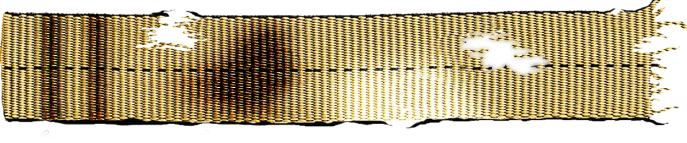

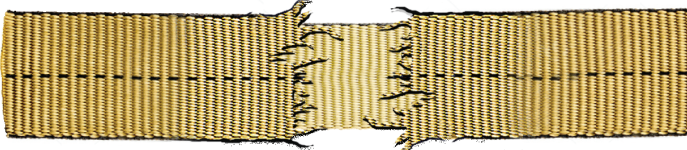
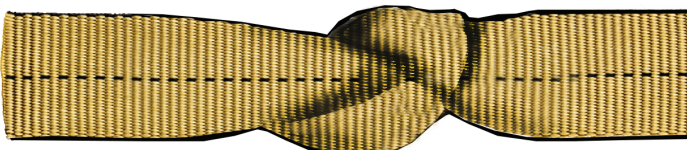

Figure 1. Lifting Slings

LIFTING AND TRANSPORTING

The Occupational Safety and Health Administration (OSHA) Regulation 29 CFR Part 1926.251 (e)(8)—*Removal from service* requires that the slings be inspected prior to each use, and **removed from service immediately** if any of the following conditions are found:

<ul style="list-style-type: none"> ■ Holes, tears, cuts, or snags ■ Embedded particles ■ Abrasive wear that exposes core fibers 	
<ul style="list-style-type: none"> ■ Missing or unreadable Rated Capacity tags ■ Melting, charring, weld spatter, or chemical burns 	
<ul style="list-style-type: none"> ■ Broken or worn stitching that exposes the core fibers 	
<ul style="list-style-type: none"> ■ Knots 	
<ul style="list-style-type: none"> ■ Any other condition which may cause doubt as to the strength of the sling 	

LIFTING AND TRANSPORTING

LIFTING PROCEDURE

The correct lifting slings (Figure 1) have been supplied with your trowel, in accordance to its weight per Occupational Safety and Health Administration (OSHA) Regulation 29 CFR Part 1926.251—*Rigging equipment for material handling*.

WARNING
ALWAYS inspect the lifting slings **before** each use.

NOTICE
MAKE SURE the forklift has adequate lifting capacity to lift the trowel.

The proper sling hitch method for connecting the lifting slings to the ride-on trowel is the **choker hitch**. The rated capacity of the slings for this method is indicated on the sling labels. **DO NOT** use any other type of sling hitch!

1. Secure the two lifting slings to the lift loops located on the left and right side of the trowel (Figure 2).

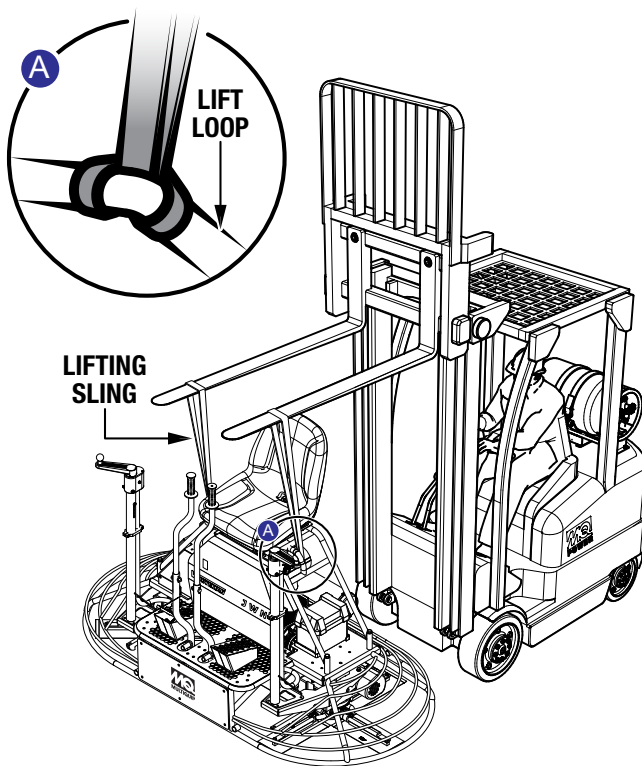

Figure 2. Lifting the Trowel

2. Insert forklift forks through the loops at the ends of the lifting slings (Figure 2). Keep the slings as close to vertical as possible. If the choke angle (Figure 3) is 120 degrees or less, the lifting strength of the slings must be de-rated as shown in Table 1, in accordance with ASME Standard B30.9.

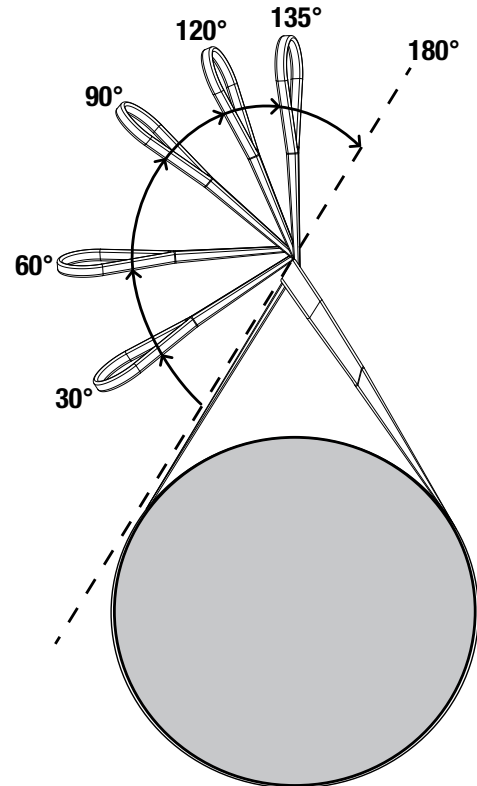

Figure 3. Choke Angle

Table 1. Choker Hitch Sling Capacity	
Choke Angle (°)	Rated Capacity (%)
Over 120	100
90–120	87
60–89	74
30–59	62
0–29	49

SPECIFICATIONS

Table 2. Trowel Specifications

Operating Weight	741 lb. (336 kg)
Shipping Weight	960 lb. (435 kg)
Fuel Tank Capacity	5 gallons (18.9 liters)
Min. Rotor Speed (Dry Concrete)	180 rpm
Path Width	75 in. (191 cm)
Gearbox Oil Capacity	28 oz.
Gearbox Oil Type	Chevron Cetus® HiPerSYN 460

Table 3. Engine Specifications

Model	Honda GX690RTAF
Type	4-stroke, overhead valve, 90-degree V-twin, 2-cylinder, gasoline engine
Piston Displacement	40.9 in. ³ (670 cm ³)
Max. Output	22.1 bhp/3,600 rpm (16.5 kW)
Max. Torque	35.6 lbf-ft. at 2,500 rpm
Cooling System	Forced air
Engine Oil Capacity	1.6 quarts (1.5 liters) 1.8 quarts (1.7 liters) with oil filter replacement
Fuel Type	Unleaded gasoline, octane rating of 86 or higher Maximum 10% ethanol See engine manual for further details.
Fuel Consumption	1.71 gph
Starting System	Electric start/CDI-type magneto ignition
Spark Plug Type	ZFR5F NGK
Spark Plug Gap	0.028–0.031 in. (0.70–0.80 mm)
Length	16.9 in. (42.9 cm)
Height	17.2 in. (43.8 cm)
Width	17.7 in. (45.0 cm)
Weight (Dry)	99.9 lb. (45.3 kg)

Table 4. Noise and Vibration Emissions

Guaranteed ISO 11201:2010 Based Sound Pressure Level at Operator Station in dB(A)	92
Guaranteed ISO 3744:2010 Based Sound Power Level in dB(A)	112
Whole Body Vibration Per ISO 2631-1:1997 +A1:2010 in m/s ² Σ A(8)	0.15

NOTES:

1. Sound pressure and power levels are “A” weighted measures per ISO 226:2003 (ANSI S1.4-1981). They are measured with the operating conditions of the machine which generate the most repeatable but highest values of the sound levels. Under normal circumstances, the sound level will vary depending on the condition of the material being worked upon.
2. The vibration level indicated is the vector sum of the RMS (root mean square) values of amplitudes on each axis, standardized to an 8-hour exposure period, and obtained using operating conditions of the machine that generate the most repeatable but highest values in accordance with the applicable standards for the machine.
3. Per EU Directive 2002/44/EC, the daily exposure action value for whole body vibration is 0.5 m/s² Σ A(8). The daily exposure limit value is 1.15 m/s² Σ A(8).

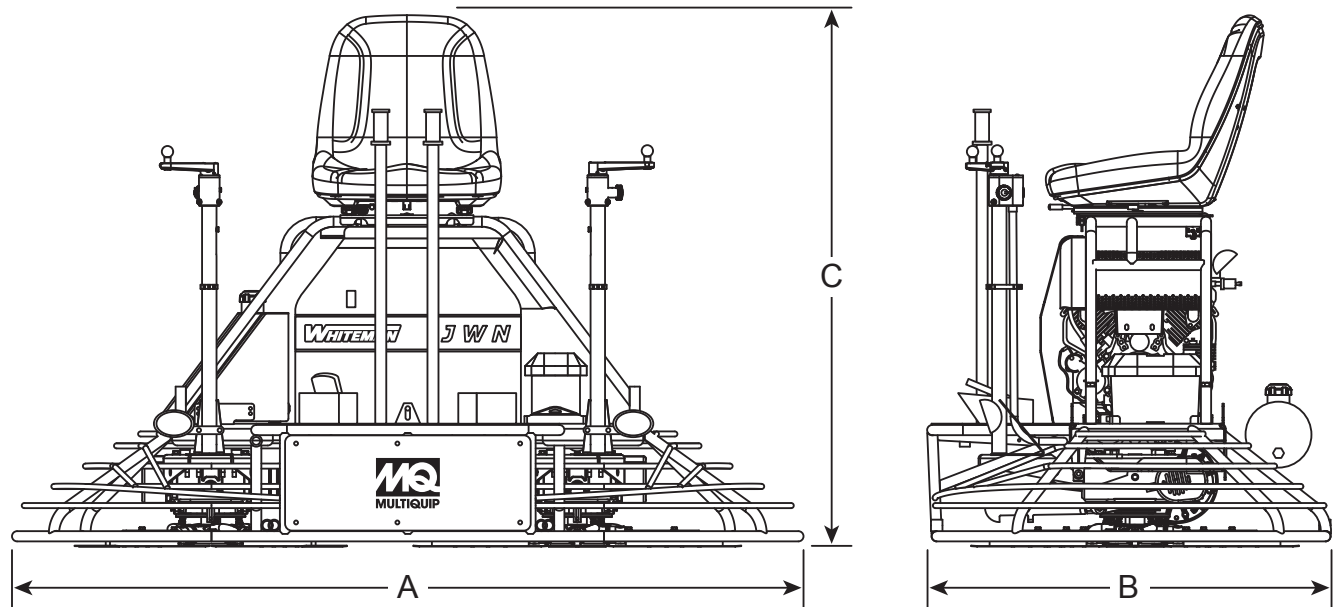

Figure 4. Trowel Dimensions

Table 5. Trowel Dimensions	
Measurement	in. (cm)
(A) Length	77 (195.6)
(B) Width	39 (99.1)
(C) Height	46.75 (118.7)

GENERAL INFORMATION

JWN SERIES RIDE-ON POWER TROWEL FAMILIARIZATION

The JWN Series Ride-On Power Trowel is designed for the floating and finishing of concrete slabs.

Take a walk around your trowel. Take notice of all the major components like the engine, blades, air cleaner, fuel system, fuel shut-off valve, ignition switch, etc. Check that there is always oil in the engine, and gear oil in the gearbox assembly.

Read all the safety instructions carefully. Safety instructions will be found throughout this manual and on the machine. Keep all safety information in good, readable condition. Operators should be well trained on the operation and maintenance of the trowel.

Look at the operator control levers. Grab the control levers and move them around a bit. Notice how moving the control levers causes the gearboxes and frame to move.

Notice the foot pedal which controls the engine speed. Also take a look at the main driveline of the trowel. Take note and reference how the belts look, this is the way the belts should look when adjusted properly.

Before using your trowel, test it on a flat, watered-down section of finished concrete. This trial test run will increase your confidence in using the trowel and at the same time it will familiarize you with the trowel's controls and indicators. In addition you will understand how the trowel will handle under actual operating conditions.

ENGINE

This trowel is equipped with an air-cooled, 24-horsepower, Honda gasoline engine. Refer to the engine owner's manual for specific instructions regarding engine operation. This manual is included with the trowel at the time of shipping. Please contact your nearest Multiquip dealer for a replacement should the original manual become lost or damaged.

BLADES

The blades of the trowel finish the concrete as they are swirled around the surface. Blades are classified as *combination* (10 or 8 inches wide) or *finish* (6 inches wide). This trowel is equipped with four blades per rotor equally spaced in a radial pattern and attached to a vertical rotating shaft by means of a spider assembly.

Figure 5 and Figure 6 show the location and functions of the controls, indicators and general maintenance parts. Some controls may perform more than one function.

GEARBOXES

The JWN Series Ride-On Power Trowel uses two separate gearbox assemblies that are enclosed in rugged cast aluminum gear cases.

The gearbox casing has a large oil capacity allowing optimum lubrication to critical points.

STEERING ASSIST

Dual control levers located in front of the operator's seat are provided for steering the trowel. The control levers are linked to two spring-loaded cylinders.

Push the left control lever forward and pull the right control lever backward and the trowel will rotate clockwise on approximately a center axis. Pull the left control lever backward and push the right control lever forward and the trowel will rotate counterclockwise. See Table 7 for a complete description of the control levers' directional positioning.

CONSTANT VELOCITY JOINTS (CV-JOINTS)

Constant velocity joints ensure the efficient transfer of power to the drive shaft and maintain the timing of the gearboxes without any chance of slippage.

TRAINING

For training, please use the **Training Checklist** located in the front of this manual. This checklist is not intended to be a substitute for proper training, but will provide an outline for an experienced operator to provide training to a new operator.

COMPONENTS (TROWEL)

1. **Seat** — The engine will not start unless the operator is seated.
2. **Steering Control Levers** — Direct the unit forward, reverse, left, or right.
3. **Retardant Spray Control Button** — Sprays retardant through the nozzle at the front of the machine.
4. **Twin Pitch Control** — Both pitch towers are linked together. One crank may be turned to adjust the blade pitch simultaneously or individually controlled for each set of blades. Turn the crank as marked on its top surface to increase or decrease blade pitch.
5. **Light Switch** — Turns on three halogen lights. Two in front, one in rear.
6. **Ignition Switch** — With the key inserted, turn clockwise to start the engine.
7. **Hour Meter** — Indicates the number of hours the engine has run.
8. **Choke Control Lever** — In cold weather, pull this lever to start the engine. After the engine warms, push the knob all the way in.
9. **Fuel Gauge/Filler Cap** — Indicates the amount of fuel in the fuel tank. Remove this cap to add fuel.

! DANGER

Add fuel to the tank only when the engine is stopped and has had an opportunity to cool down. In the event of a fuel spill, **DO NOT** attempt to start the engine until the fuel residue has been completely wiped up and the area surrounding the engine is dry.

10. **Fuel Tank** — Holds 5 gallons of unleaded gasoline.
11. **Left Foot Riser** — Operator foot rest pedal.
12. **Spray Nozzle** — Spray nozzle for retardant.
13. **Right Foot Pedal** — Controls blade speed. Slow blade speed is obtained by slightly depressing the foot pedal. Maximum blade speed is obtained by fully depressing the foot pedal.
14. **EZ Mover Boss** — Front attachment point for EZ Mover. Used for transporting the trowel.
15. **Right Front Light** — 12-volt halogen lights, used for night operations.
16. **Left Front Light** — 12-volt halogen lights, used for night operations.

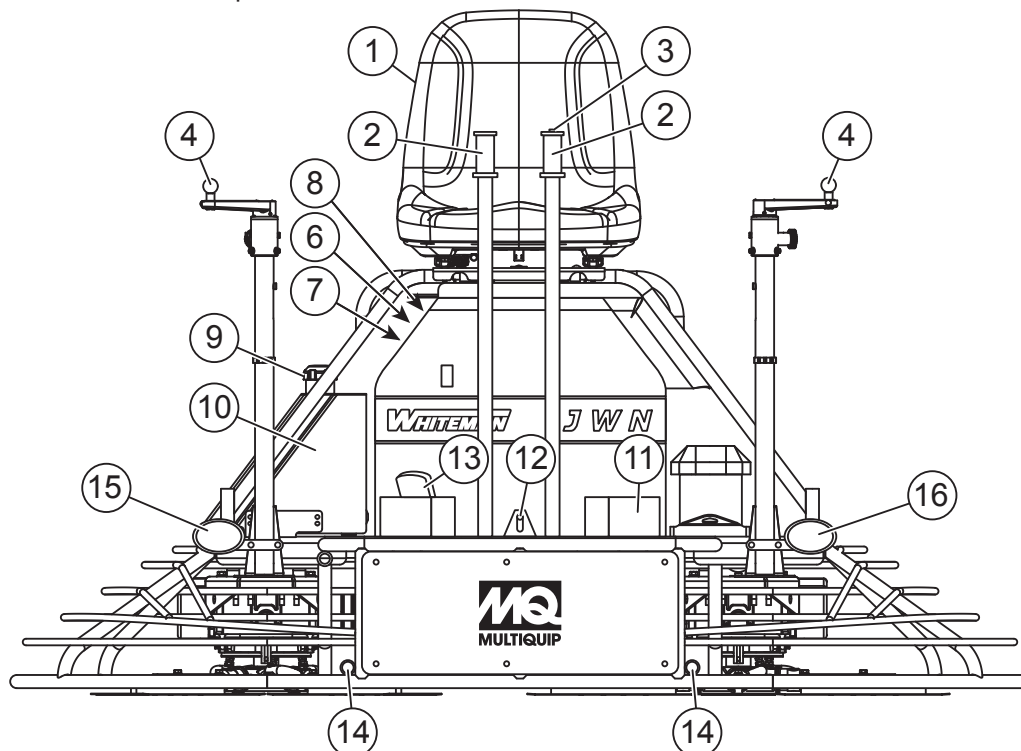

Figure 5. Components – Front

COMPONENTS (TROWEL)

17. **Rear Light** — The JWN Series ride-on power trowel has three 12-volt halogen lights.
18. **Lift Loops** — Located on both sides of the main frame. Used for lifting the trowel.
19. **Retardant Spray Tank** — Holds 5 gallons of retardant.
20. **Retardant Spray Pump** — Delivers retardant to the spray nozzle.
21. **EZ Mover Boss** — Rear attachment point for EZ Mover. Used for transporting the trowel.
22. **Right-Side Spider** — Consists of trowel arms, blades, wear plate, and thrust collar.
23. **Left-Side Spider** — Consists of trowel arms, blades, wear plate, and thrust collar.
24. **Document Box** — Contains all product documentation.
25. **Battery** — Provides +12V DC power to the electrical system.
26. **Belt Guard** — Encloses the drive belt used in conjunction with the clutch.
27. **Charcoal Canister** — Charcoal-activated system that absorbs or traps fuel vapors. Basic component of evaporative emissions control systems.
28. **Safety Kill Switch** — Shuts down the engine when the seat is not occupied by an operator.

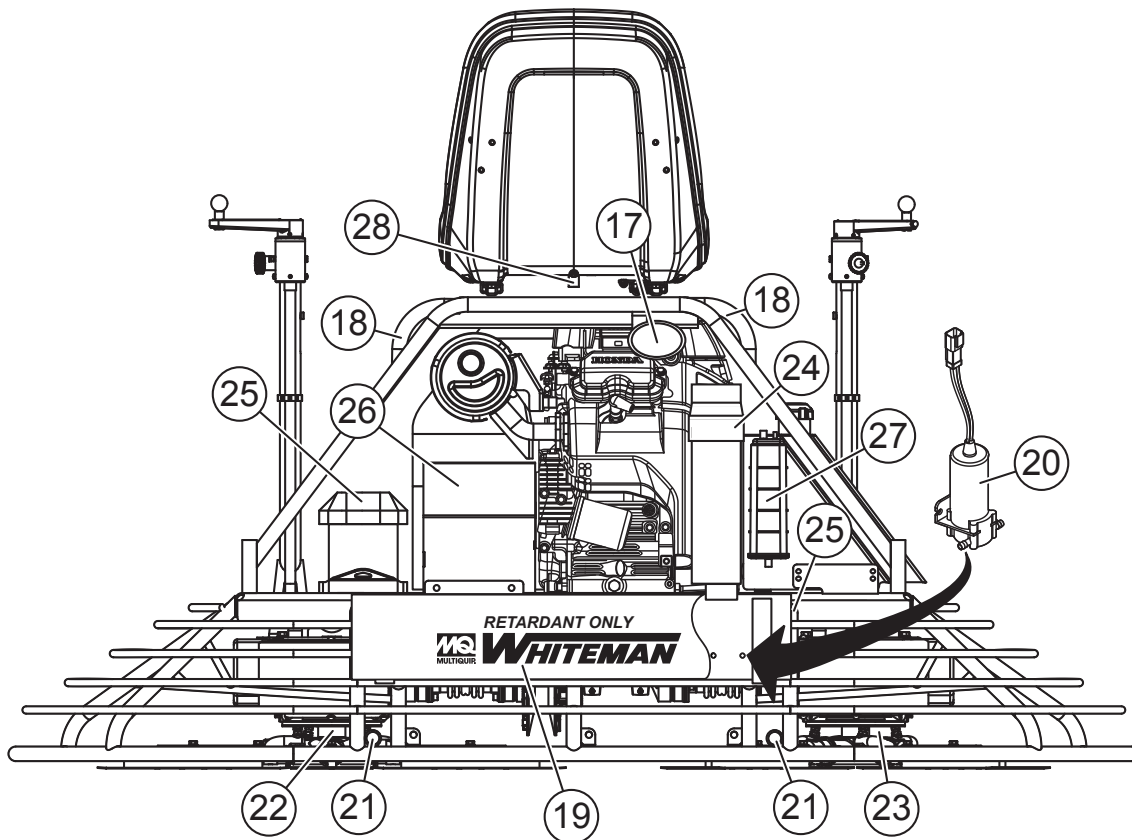

Figure 6. Components – Rear

COMPONENTS (ENGINE)

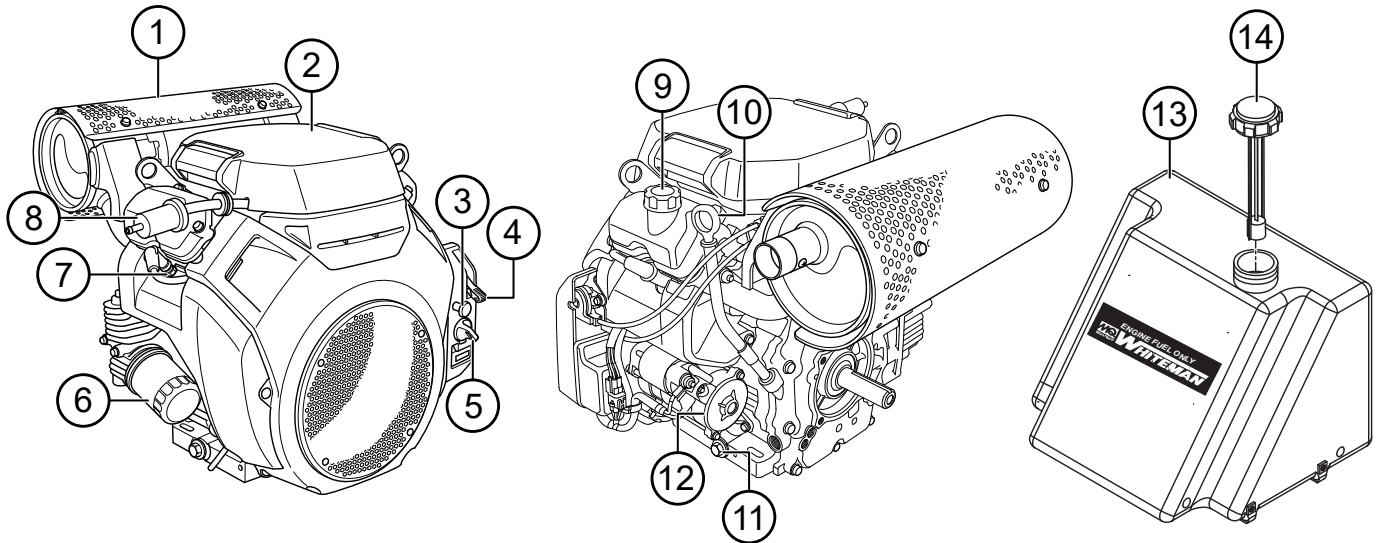



Figure 7. Engine Components

INITIAL SERVICING

The engine (Figure 7) must be checked for proper lubrication and filled with fuel prior to operation. Refer to the manufacturer's engine manual for instructions and details of operation and servicing.

1. **Muffler** — Reduces noise and emissions.

WARNING



Engine components can generate extreme heat. To prevent burns, **NEVER** touch these areas while the engine is running or immediately after operating. **NEVER** operate the engine with the muffler removed.

2. **Air Cleaner** — Prevents dirt and other debris from entering the fuel system. Unsnap the air filter cover to gain access to the filter element.
3. **Choke Knob** — Used in the starting of a cold engine or in cold weather conditions. The choke enriches the fuel mixture.
4. **Throttle Lever** — Controlled by the accelerator pedal, increases or decreases engine RPM.
5. **Engine ON/OFF Switch** — **ON** position permits engine starting, **OFF** position stops engine operation.
6. **Oil Filter** — Spin-on type, filters oil for contaminants.

7. **Spark Plug** — Provides spark to the ignition system. Set the spark plug gap to 0.6–0.7 mm (0.028–0.031 inch) Clean the spark plug once a week.
8. **Fuel Filter** — Filters fuel for contaminants.
9. **Oil Filler Cap** — Remove to add engine oil.
10. **Oil Dip Stick** — Remove to check the amount and condition of oil in the crankcase.
11. **Oil Drain Plug** — Remove to drain crankcase oil.
12. **Starter** — Starts the engine when the ignition key is rotated to the **ON** position.
13. **Fuel Tank** — 5-gallon capacity. Use unleaded gasoline.
14. **Fuel Filler Cap** — Remove this cap to add unleaded gasoline to the fuel tank. Make sure the cap is tightened securely. **DO NOT** overfill.

DANGER



Add fuel to the tank only when the engine is stopped and has had an opportunity to cool down. In the event of a fuel spill, **DO NOT** attempt to start the engine until the fuel residue has been completely wiped up and the area surrounding the engine is dry.

The purpose of this section is to assist the user in setting up a **NEW** trowel. If your trowel is already assembled (seat, handles, knobs, and battery), this section can be skipped.

NOTICE

The new trowel cannot be placed into service until the setup installation instructions are completed.

Before packaging and shipping, this JWN Series ride-on power trowel was run and tested at the factory. If there are problems, please let us know.

CONTROL HANDLE ASSEMBLY

The steering control handles are not attached to the trowel's two lower handles at the time of shipment. To attach the steering control handles to the two lower handle assemblies, perform the following:

1. Remove the bolts from the plastic bag tied to the control towers.
2. Remove all protective wrapping and straps from the control handles.
3. Slip the top (loose) piece into the base of the corresponding handle, making sure to line up the holes.
4. Install the bolt through the lined-up holes and tighten the acorn nut onto the threaded end.

NOTICE

Some models are equipped with adjustable height handles. Adjust the height by placing the bolt through the set of holes that corresponds to the most comfortable height.

5. Pay close attention to any wires that may be inside the control handles. **DO NOT** pinch or cut any wires during installation.
6. Inside the plastic bag of parts are two knobs for the pitch control tower cranks. Install these two knobs onto the tower crank levers.

SEAT ASSEMBLY

The seat is not installed on the trowel for shipping purposes. To attach the seat perform the following:

1. Remove the seat from the protective wrapping.
2. Insert the studs on the bottom of the seat through the holes in the mounting plate.
3. Install and tighten the provided nuts.

BATTERY SETUP

This trowel was shipped with a wet-charged battery. This battery may need to be charged for a brief period of time as per the manufacturer's instructions.

CAUTION

Use all safety precautions specified by the battery manufacturer when working with the battery. Refer to the **Safety Information** section of this manual for additional information.

To install the battery onto the trowel, make sure that the battery is well seated in the battery box. Connect the positive cable to the positive terminal on the battery first, then connect the negative cable to the negative terminal. Close the plastic battery box cover and secure the battery box.

ENGINE OIL LEVEL

NOTICE

ALWAYS check engine oil before each use.

1. Pull the engine oil dipstick (Figure 8) from its holder.

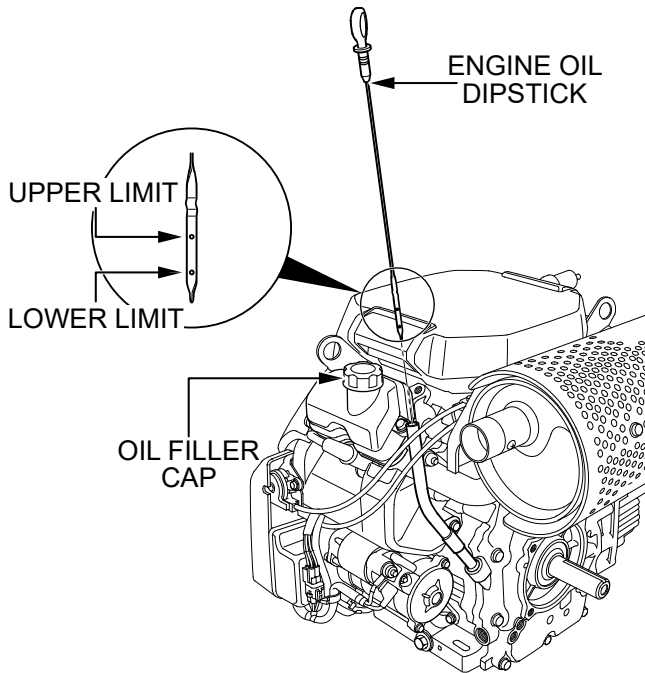

Figure 8. Engine Oil Dipstick

2. Determine if engine oil is low.

NOTICE

To prevent extensive engine wear or damage, always maintain the proper oil level in the crankcase. **NEVER** operate the engine with the oil level outside of the upper and lower limit marks on the dipstick (Figure 8).

3. If engine oil is low, remove the oil filler cap (Figure 8), and add the correct amount of engine oil to bring the oil to a normal, safe level. Use oil as recommended in Table 6.

Table 6. Recommended Viscosity Grades

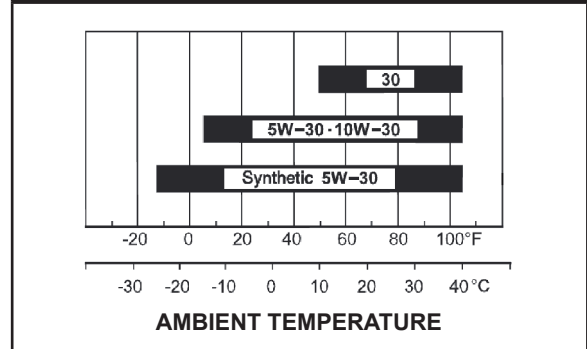

GEARBOX OIL LEVEL

1. Check the gearbox oil level in both gearboxes by removing the fill plug and ensuring that the oil is at the correct level. See Figure 9.

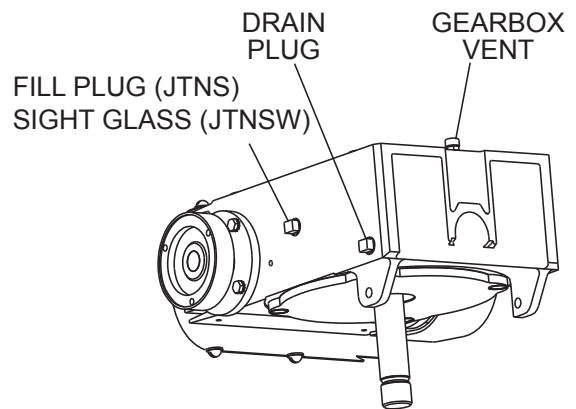

Figure 9. Gearbox Oil Plugs/Sight Glass

2. Fill the gearbox just to the level of the fill plug (Figure 9) with Chevron Cetus® HiPerSYN 460 synthetic gear oil if necessary.

NOTICE

Gearbox oil capacity is approximately 28 oz.

FUEL LEVEL

DANGER



Handle fuel safely. Motor fuels are highly flammable and can be dangerous if mishandled. **NEVER** smoke while refueling. **NEVER** attempt to refuel while the engine is running or hot. In the event of a fuel spill, **DO NOT** attempt to start the engine until the fuel residue has been completely wiped up and the area surrounding the engine is dry.

Determine if engine fuel is low (Figure 10). If the fuel level is low, remove the fuel filler cap and fill with unleaded gasoline.

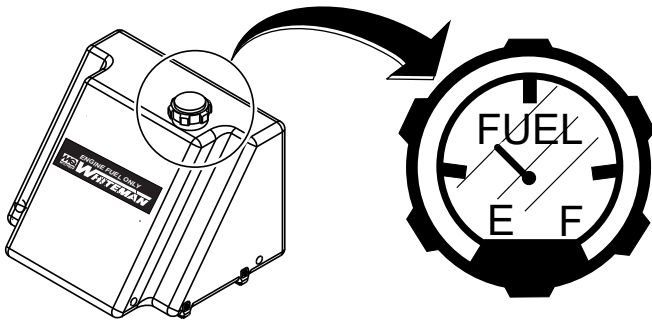

Figure 10. Fuel Gauge

OPERATION

The instructions in this manual are provided as a basic guide to trowel operation, **not** a complete guide to concrete finishing. We suggest that all operators (experienced and novice) read *Slabs on Ground* published by the American Concrete Institute.

DO NOT use your ride-on power trowel until this section is thoroughly understood.

CAUTION

Failure to understand the operation of the trowel could result in **severe personal injury** or damage to the machine.

IMPORTANT INFORMATION BEFORE YOU START

1. This ride-on trowel is equipped with a safety stop switch. The switch is located beneath the seat assembly. Remember that the engine will not start unless an operator is sitting in the operator's seat. The weight of the operator depresses an electrical switch which allows the engine to start.

WARNING

NEVER disable or disconnect the safety stop switch. It is provided for operator safety and **injury or death may result** if it is disabled, disconnected or improperly maintained.

2. The safety stop switch should be used to stop the engine after every use. Doing this will verify that the switch is working properly, thus providing safety for the operator. Remember to turn the key to the **OFF** position after stopping the machine. Not doing so will drain the battery.

3. The right foot pedal (Figure 11) controls blade and engine speed. The position of the foot pedal determines the blade speed. Slow blade speed is obtained by slightly depressing the pedal. Maximum blade speed is obtained by fully depressing the pedal.

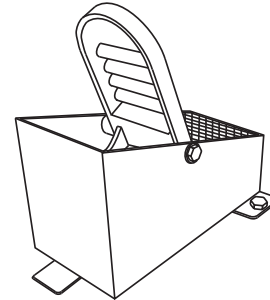

Figure 11. Blade Speed Control Foot Pedal

STARTING THE ENGINE

1. With one foot on the ground and the other foot placed on the trowel's platform, grab the frame near the seat and lift yourself onto the trowel. Sit in the operator's seat and ensure the control handles, foot pedal, and control panel items can be comfortably accessed.
2. When starting a cold engine, pull the choke knob (Figure 12) out to the **CLOSED** position. In warm weather or when the engine is warm, the unit can be started with the choke halfway or completely open.

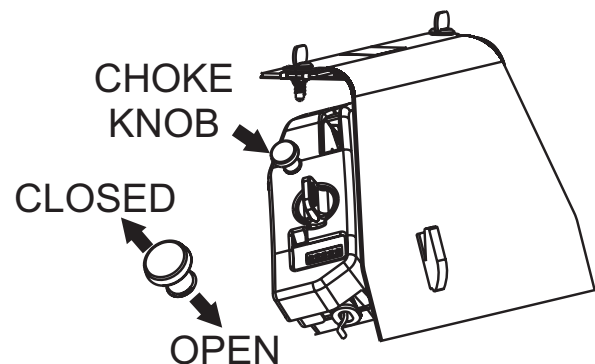

Figure 12. Choke Knob

3. **ALWAYS** keep your foot *off* the blade speed control pedal and start the engine at **idle** (without touching the pedal).

4. Insert the ignition key (Figure 13) into the ignition switch.

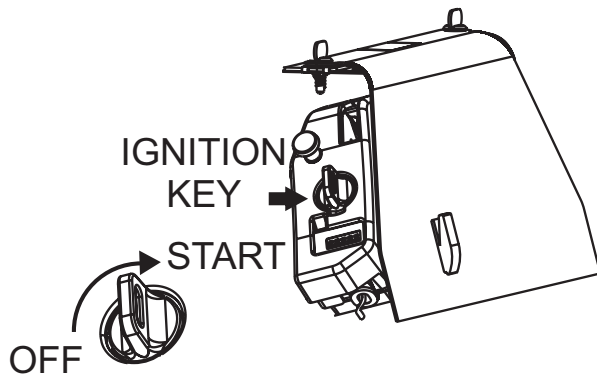

Figure 13. Ignition Key

5. Turn the ignition key clockwise and listen for the engine to start. Once the engine starts, release the ignition key.
6. If the engine fails to start in this manner, consult the engine owner's manual supplied with the trowel.
7. Test the safety stop switch by standing up briefly. The switch under the seat should cause the engine to stop. If the switch fails to shut down the engine, turn off the engine with the key switch and repair the safety stop switch. See the **Troubleshooting** section for possible causes.
8. Let the engine idle for 3–5 minutes. If choke is applied, push the choke to the open position as soon as the engine will run smoothly.

STEERING

Two control levers located in front of the operator's seat provide directional control for the trowel. Table 7 illustrates the various directional positions of the joysticks and their effect on the ride-on trowel.

1. Push both the left and right control levers forward. See Figure 14.

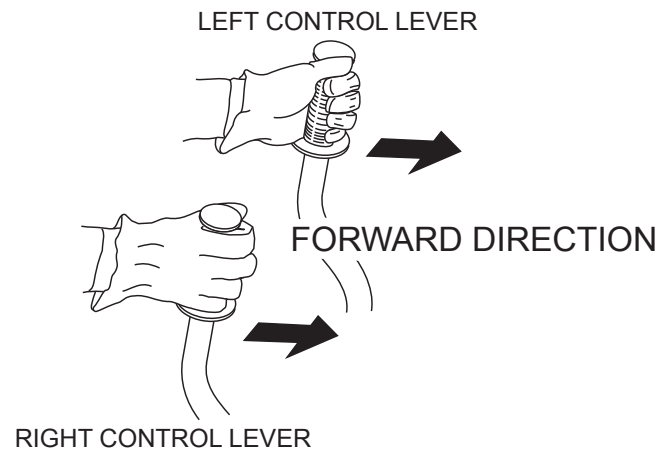























Figure 14. Left and Right Control Levers

2. With your right foot, quickly depress the right foot pedal halfway. Notice that the trowel begins to move in a forward direction. Return both joystick controls to their neutral position to stop forward movement, then remove your right foot from the right foot pedal.
3. Practice holding the machine in one place as you increase blade speed. When about 75% of maximum blade speed has been reached, the blades will be moving at proper finishing speed. The machine may be difficult to keep in one place. Trying to keep the trowel stationary is good practice for operation.
4. Practice maneuvering the trowel using the information listed in Table 7. Practice controlled motions as if you were finishing a slab of concrete. Practice edging and covering a large area.
5. Try adjusting the pitch of the blades. This can be done with the trowel stopped or while the trowel is moving, whichever feels comfortable. Test the operation of optional equipment like retardant spray and lights if equipped.
6. Pull both the left and right joysticks backward and repeat steps 3 through 5 while substituting the word *reverse* for *forward*.

Table 7. Control Lever Directional Positioning

CONTROL JOYSTICK & DIRECTION	RESULT
Move LEFT Joystick FORWARD 	 Causes only the left side of the ride-on trowel to move forward.
Move LEFT Joystick BACKWARD 	 Causes only the left side of the ride-on trowel to move backward.
Move RIGHT Joystick FORWARD 	Causes only the right side of the ride-on trowel to move forward. 
Move RIGHT Joystick BACKWARD 	Causes only the right side of the ride-on trowel to move backward. 
Move BOTH Joysticks FORWARD  	Causes the ride-on trowel to move forward in a straight line.  
Move BOTH Joysticks BACKWARD  	Causes the ride-on trowel to move backward in a straight line.  
Move BOTH Joysticks to the RIGHT  	Causes the ride-on trowel to move to the right. 
Move BOTH Joysticks to the LEFT  	Causes the ride-on trowel to move to the left. 

NOTICE

Trowel arms can be damaged by rough handling or by striking exposed plumbing or forms while in operation. **ALWAYS** look out for objects which might cause damage to the trowel arms.

When performing any maintenance on the trowel or engine, follow all safety messages and rules for safe operation stated at the beginning of this manual.

There is a **Daily Pre-Operation Checklist** at the front of this manual. Make copies of this checklist and use it on a daily basis.

WARNING

 Accidental starts can cause **severe injury or death**.

 **ALWAYS** place the ON/OFF switch in the **OFF** position.

 Disconnect and ground spark plug leads and disconnect the negative battery cable from the battery before servicing.

MAINTENANCE SCHEDULE

Check and retighten all fasteners as necessary.

Daily (8–10 Hours)

1. Check the fluid levels in the engine and gearboxes, and fill as necessary. Check the air cleaner. Refer to the following section on air filter maintenance.
2. Relube the arms, thrust collars, and steering links.

Weekly (30–40 Hours)

1. Replace blades if necessary.
2. Check and clean or replace the engine air filter as necessary. Refer to the following section on air filter maintenance.
3. Replace the engine oil and oil filter as necessary. Refer to the following section on engine oil and filter maintenance.

Monthly (100–125 Hours)

1. Remove, clean, reinstall and relube the arms and thrust collars. Adjust the blade arms.
2. Replace gearbox lubricant after the first 100 hours of operation. Replace every 500–600 hours thereafter.
3. Check the drive belt for excessive wear. Refer to the following section on drive belt maintenance.

Yearly (500–600 Hours)

1. Check and replace the arm bushings, thrust collar bushings, shaft seals, and belts as necessary.
2. Check the pitch control cables for wear.
3. Replace gearbox lubricant.

Air Cleaner (Daily)

Thoroughly remove dirt and oil from the engine and control area. Clean or replace the air cleaner elements as necessary. Check and retighten all fasteners as necessary.

1. Release the four latch tabs (Figure 15) from the air cleaner cover, and remove the cover.

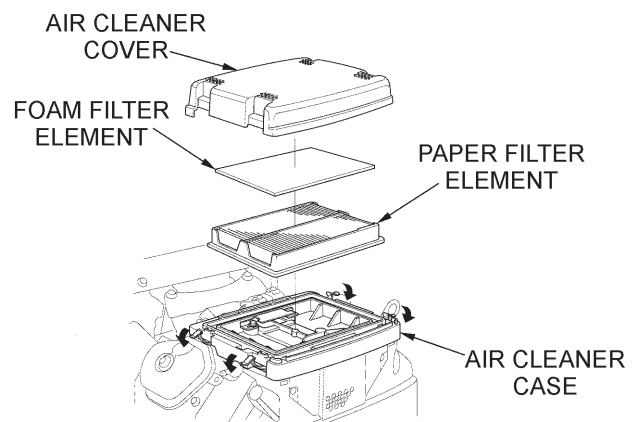

Figure 15. Air Cleaner Components

2. Remove the foam filter from the cover.
3. Remove the paper filter from the air cleaner case.
4. Inspect both air filter elements, and replace them if necessary.
5. To clean the paper air filter, tap the filter element several times on a hard surface to remove dirt, or blow compressed air—not to exceed 30 psi (207 kPa, 2.1 kgf/cm²)—through the filter element from the air cleaner case side.
6. **NEVER** try to brush off dirt; brushing will force dirt into the fibers. Replace the paper element if it is excessively dirty.
7. Clean the foam air filter element in warm, soapy water, rinse, and allow to dry thoroughly. Or clean with a nonflammable solvent and allow to dry. **DO NOT** pour any type of oil into the foam element.
8. Wipe dirt from the inside of the air cleaner body and cover using a moist cloth. Be careful to not let any dirt or debris enter the air chamber that leads to the carburetor.

9. Reinstall the foam air filter element in the air cleaner cover, then reinstall the paper air filter element and cover in the air cleaner case. Securely latch the four hook tabs on the air cleaner cover.

CAUTION

Operating the engine with a blocked grass screen, dirty or plugged cooling fins, and/or cooling shrouds removed will cause engine damage due to overheating.

Changing Engine Oil (100 Hours)

Change the engine oil after the first 20 hours of use, then every 6 months or 100 hours.

1. Remove the oil filler cap (Figure 8) and fill the engine crankcase with the recommended type oil listed in Table 6. Fill to the upper limit of the dipstick.
2. The crankcase oil capacity is 1.6 quarts (1.5 liters) without oil filter replacement, and 1.8 quarts (1.7 liters) with oil filter replacement.

Oil Filter (200 Hours)

1. Replace the engine oil filter (Figure 16) every 200 hours.

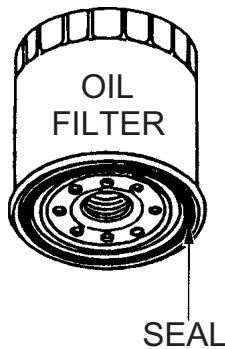

Figure 16. Oil Filter

2. Be sure to coat the seal (Figure 16) of the new oil filter with clean engine oil.

Fuel Filter (200 Hours)

1. Replace the engine fuel filter (Figure 17) every 200 hours.

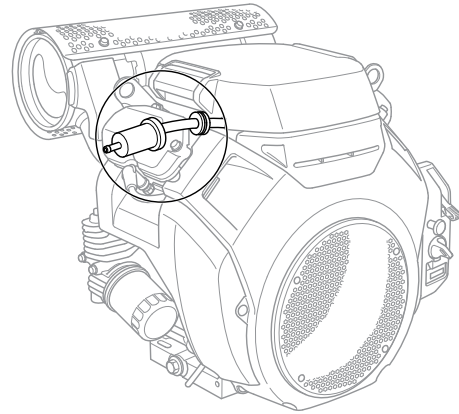

Figure 17. Fuel Filter

Oil and Fuel Lines

- Check the oil and fuel lines and connections regularly for leaks or damage. Repair or replace as necessary.
- Replace the oil and fuel lines every two years to maintain performance and flexibility.

ENGINE TUNE-UP

- See your engine manual for specific information on tuning up your engine, checking and gapping the spark plugs, etc.

NOTICE

See the engine manual supplied with your machine for an appropriate engine maintenance schedule and troubleshooting guide for problems.

TROWEL STARTUP TESTING

1. While sitting in the operator's position, start the trowel as shown in the **Operation** section. Be sure to check the engine oil level prior to starting the engine.

CAUTION

The engine's exhaust contains harmful emissions. **ALWAYS** have adequate ventilation when operating. Direct exhaust away from nearby personnel.

2. Bring the throttle up so that the clutch engages. Cycle the engine from idle to full throttle twice, then shut down the engine. Remove the key.

NOTICE

This section is intended to aid users in the maintenance of drive assemblies with the new style Multi-Clutch.

CHECKING THE DRIVE BELT

WARNING



NEVER attempt to insert hands or tools into the belt area while the engine is running. **NEVER** run the engine with the safety guards removed. Keep fingers, hands, hair and clothing away from all moving parts to prevent bodily injury.

WARNING



NEVER remove the drive belt guard until the muffler has cooled. Allow the entire trowel to cool down before performing this procedure.

The drive belt needs to be replaced as soon as it starts to show signs of wear. **NEVER** use a defective drive belt under any circumstances. Indications of excessive belt wear are fraying, squealing when in use, a belt that emits smoke, or a burning rubber smell when in use.

Under normal operating conditions, a drive belt may last approximately 150 hours. If your trowel is not reaching this kind of life span for drive belt wear, check the drive belt for proper pulley alignment and spacing.

To gain access to the drive belt, remove the drive belt guard (Figure 18), then visually inspect the drive belt for signs of damage or excessive wear. Replace the drive belt if it is worn or damaged.

BELT GUARD REMOVAL

1. To gain access to the drive belt, remove the drive belt guard (Figure 18).

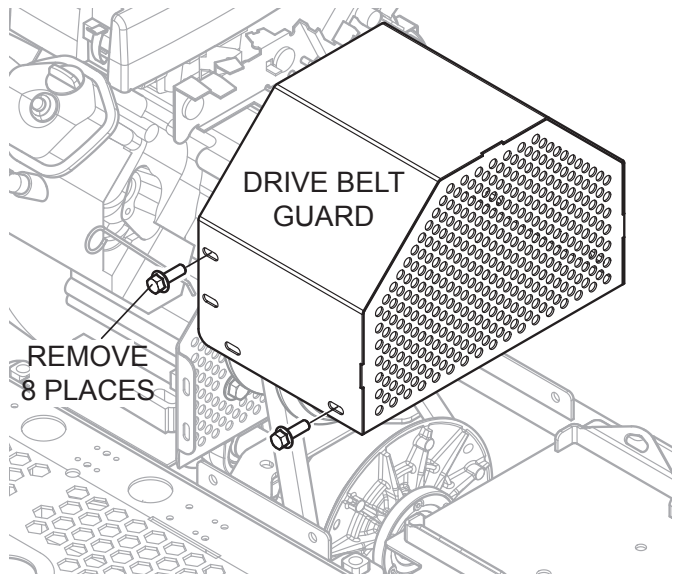

Figure 18. Drive Belt Guard Removal

SPARE DRIVE BELT REMOVAL (USING THE REPLACEMENT DRIVE BELT)

The JWN Series ride-on power trowel is equipped with a spare (replacement) drive belt carrier, which is mounted on the inboard side of the left-side gearbox. **ALWAYS** make sure there is a spare drive belt in the drive belt carrier before the trowel is placed on a slab to finish concrete.

In the event of a drive belt failure, the spare drive belt can be used for quick replacement at the job site for continued trowel operation.

1. To replace an existing drive belt with the spare drive belt, remove the 2 bolts that secure the spare belt holder to the left-side gearbox adapter plate (Figure 19). Take care to not contaminate the replacement drive belt with grease or dirt.

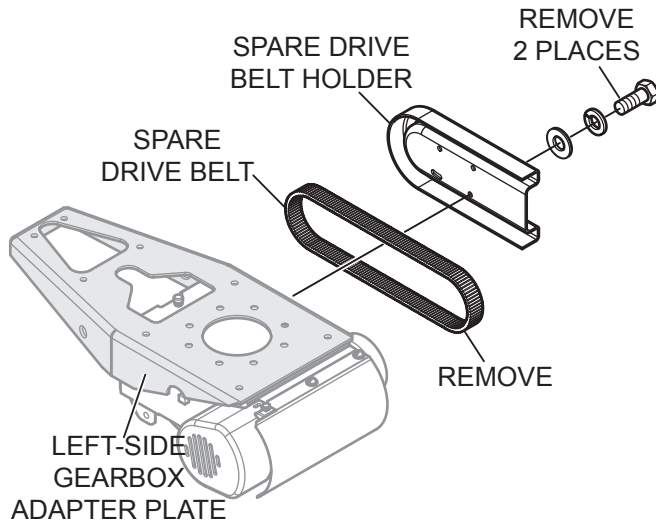

Figure 19. Spare Belt Removal

2. Cut and remove the existing drive belt from the clutch and lower drive pulley.
3. Ensure all remnants of the old drive belt have been removed from the sheaves/grooves of the clutch and lower pulley.
4. Slide the spare drive belt over the CV-joint (Figure 20) and onto the lower drive pulley.

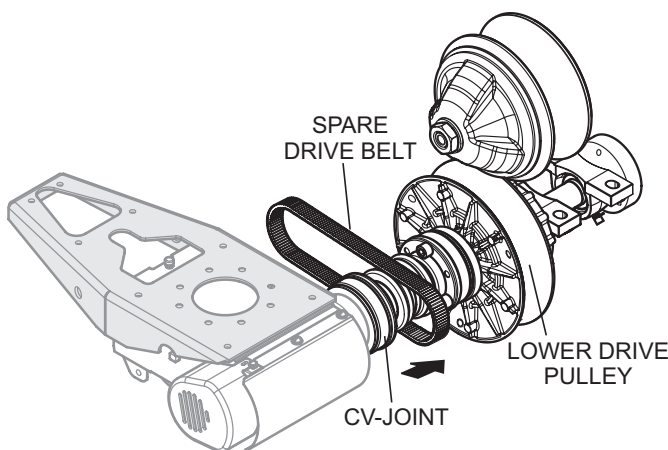

Figure 20. Spare Drive Belt Routing

5. Squeeze the drive belt (Figure 21) and pull upwards and towards the rear of the trowel. This will spread open the faces of the lower drive pulley.

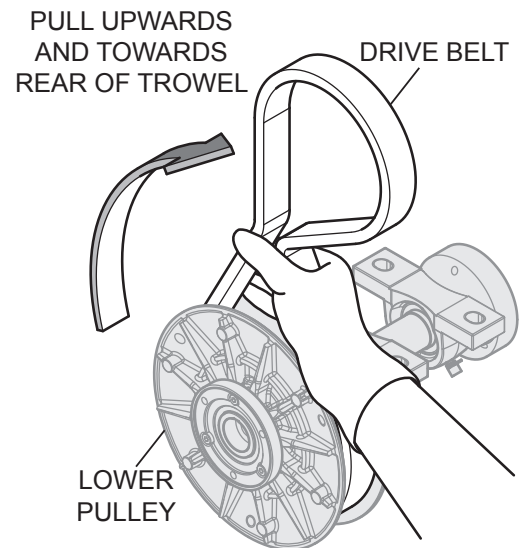

Figure 21. Spare Drive Belt Placement (Lower Pulley)

6. Place the spare drive belt onto the clutch as shown in Figure 22.

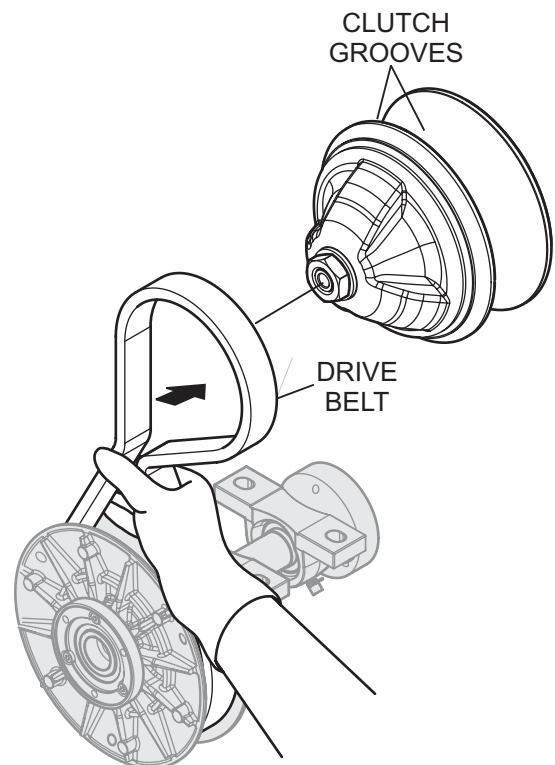

Figure 22. Spare Drive Belt Placement (Clutch)

7. Reinstall the belt guard assembly.

SPARE DRIVE BELT INSTALLATION

CV-Joint Assembly Removal (Left-Side)

1. If necessary, place the trowel on suitable supports (jack stands) and observe all safety precautions.
2. Starting at the left-side gearbox, use a 1/4" Allen wrench and remove the 3 bolts and lock washers that secure the CV-joint (Figure 23) to the left-side gearbox. Retain the mounting hardware for later use.

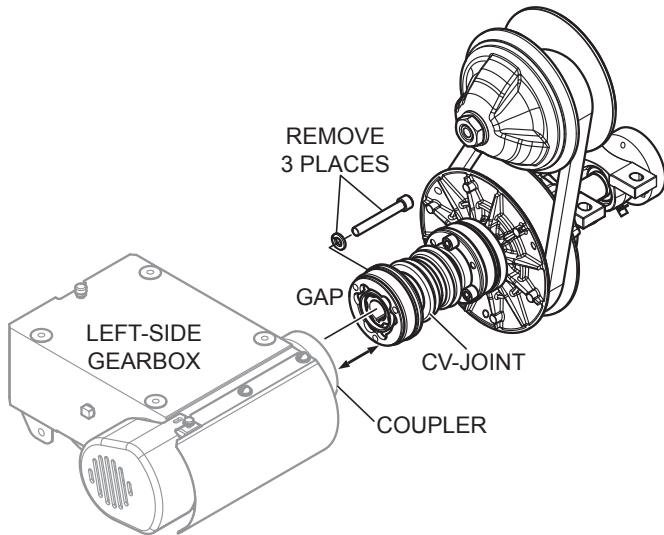

Figure 23. CV-Joint Removal

3. Once the CV-joint has been separated from the left-side gearbox coupler, push the CV-joint inward so that a gap exists between the gearbox coupler and CV-joint (Figure 23).
4. Slide the new spare drive belt between the gearbox coupler and CV-joint.

5. Mount the new spare drive belt and cover (Figure 24) onto the left-side gearbox. Reinstall the 2 bolts that secure the spare belt holder to the left-side gearbox adapter plate.

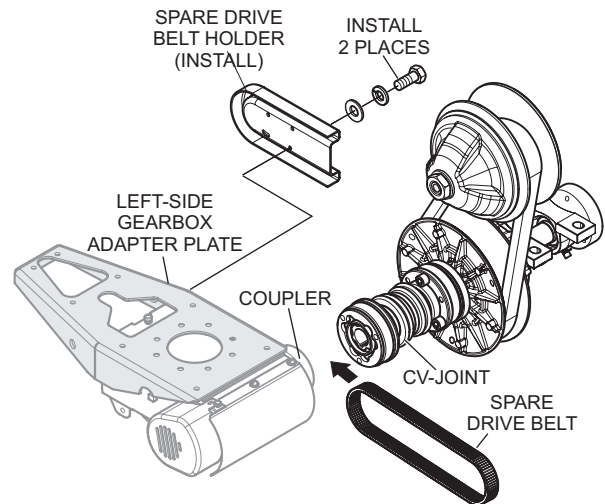

Figure 24. Spare Drive Belt Routing

CV-Joint Assembly Installation (Left-Side)

1. Apply a thin coat of RTV silicone (Figure 25) to the mating surfaces of the CV-joint and left-side gearbox coupler.

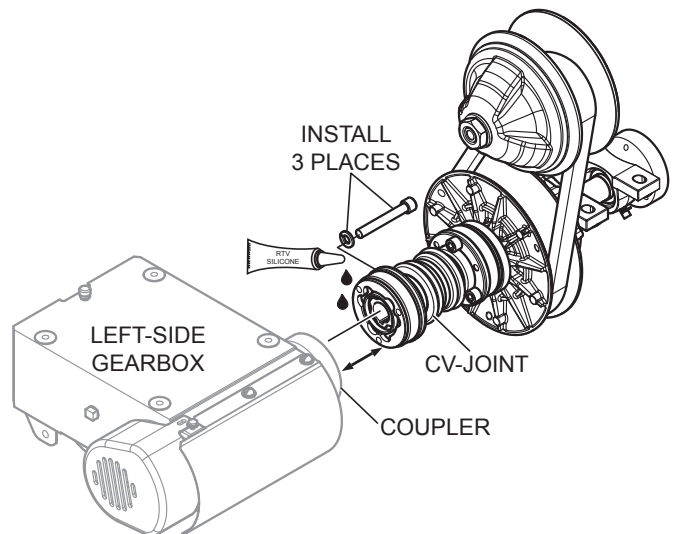

Figure 25. CV-Joint Installation

2. Using a 1/4" Allen wrench, install the 3 bolts and lock washers that secure the CV-joint (Figure 25) to the left-side gearbox.

HOW IT WORKS

The Multi-Clutch functions much like a standard CVT system. As engine RPMs increase, the drive or primary clutch closes, forcing the belt to ride outwards on the drive sheaves. The closing of the drive clutch also forces the belt to open the driven or secondary sheaves. The opening and closing of these sheaves creates a ratio variation—hence *continuously variable transmission* or *CVT*.

Belt protection is achieved within the Multi-Clutch through the use of a series of centrifugal clutches. Most CVT systems have a loose or slack belt while the engine idles, and the sheaves of those systems are constantly rotating and wearing on the belt.

Traditional CVT systems also require the stationary belt to be pinched by the constantly rotating sheaves during startup. The rotation of the sheaves relative to the belt causes unnecessary wear on the belt. With such systems, wear on the belt happens any time the engine idles, as well as at every startup of the driven equipment. This is how the Multi-Clutch differs from other CVTs.

The Multi-Clutch utilizes two centrifugal clutches (the starter clutch system) to drive the sheaves of the drive (primary) clutch. This means the belt can remain tight in the sheaves, and that both the sheaves and the belt are stationary while the vehicle is idling. This eliminates belt wear at idle and during startup, while also providing an additional form of belt protection.

The centrifugal clutches (starter clutch) can act as overload protection as well. In situations where too much torque is being transmitted to the belt, the centrifugals can slip before the maximum load on the belt is achieved. This means that instead of the belt slipping on the sheaves during an overload, the centrifugals will slip first, further protecting the belt from damage.

TROWEL LUBRICATION

Regular lubrication is required to maintain your trowel in optimal working condition. Schedule maintenance lubrication according to Table 8.

Table 8. Trowel Lubrication Schedule		
Location	# of Shots	Interval
Spiders	1 to 1½	Every day
Pillow Blocks	1	Every day
Pitch Levers	1	Once a month
Pitch Towers	1	Every 6 months

Spiders (Daily)

Perform the following lubrication procedure after **every 8 hours of use**.

1. Locate one of the Zerk grease fittings on either spider assembly (Figure 26). Remove the Zerk fitting cap and set it aside.

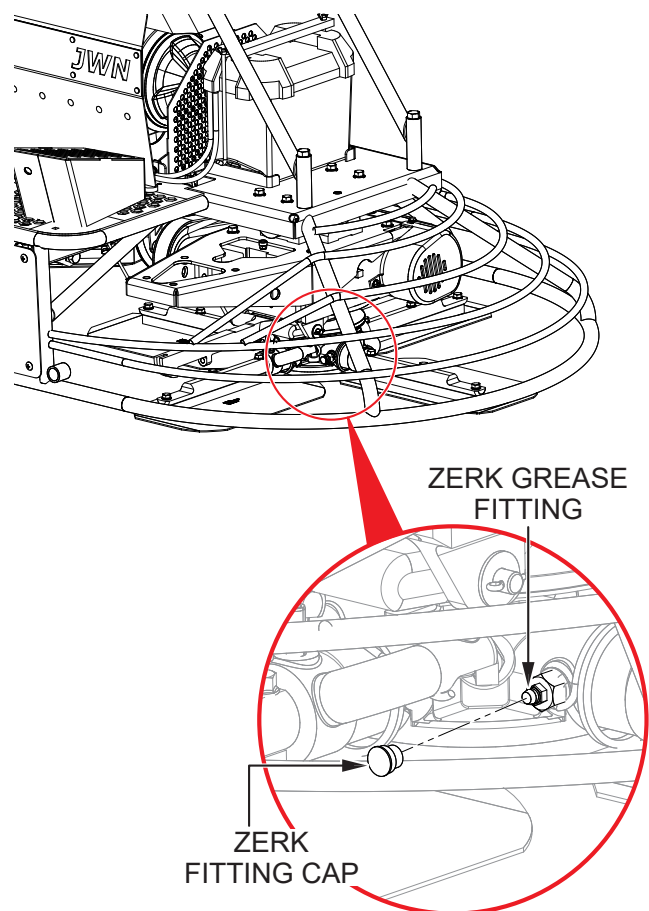

Figure 26. Spider Lubrication

MAINTENANCE

2. Wipe the Zerk grease fitting clean to prevent abrasive material from entering the fitting during lubrication.
3. Lubricate the Zerk grease fitting with 1–1½ shots of multipurpose grade grease. Replace the Zerk grease fitting cap when finished.
4. Repeat steps 1–3 for the remaining grease fittings on both spider assemblies.

Pillow Block Bearings (Daily)

Perform the following lubrication procedure after **every 8 hours of use**.

1. Locate the grease port plate (Figure 27) at the rear of the trowel, just behind the fuel tank. These two Zerk grease fittings lubricate the pillow block bearings.

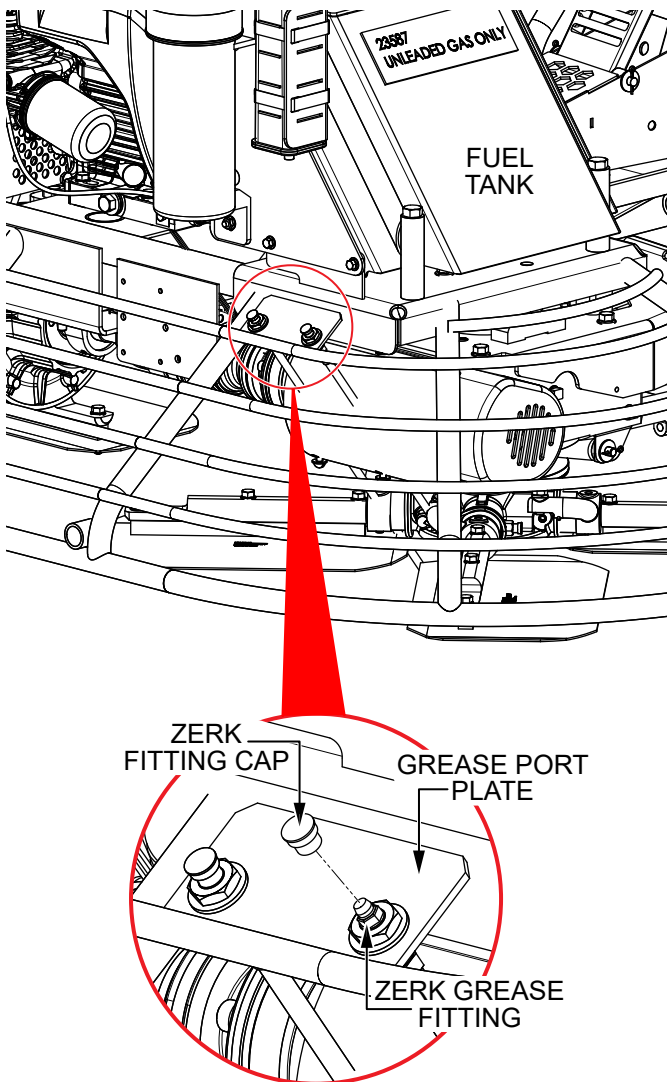

Figure 27. Pillow Block Bearing Lubrication

2. Remove the Zerk grease fitting caps and set them aside.
3. Wipe the Zerk grease fittings clean to prevent abrasive material from entering the fittings during lubrication.
4. Lubricate each Zerk grease fitting with one shot of multipurpose grade grease. Replace the Zerk grease fitting caps when finished.

Pitch Adjustment Levers (Monthly)

Perform the following lubrication procedure **once a month**.

1. Locate the Zerk grease fitting next to the knob on either pitch adjustment lever (Figure 28). Remove the Zerk grease fitting cap and set it aside.

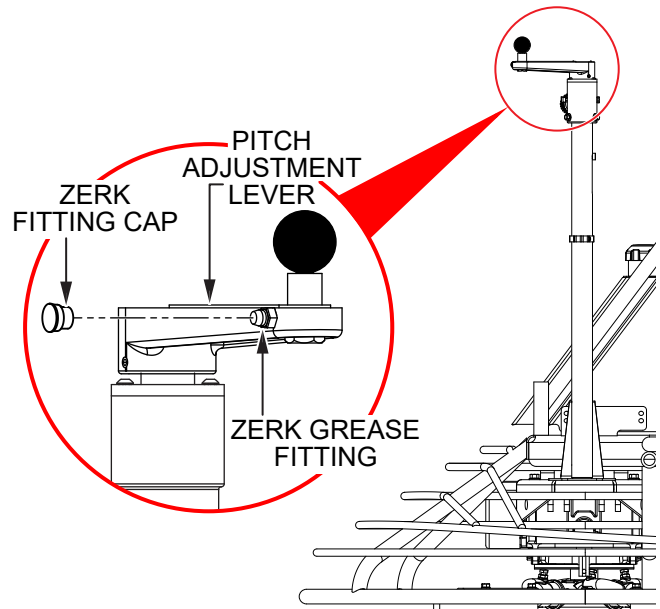

Figure 28. Pitch Adjustment Lever Lubrication

2. Wipe the Zerk grease fitting clean to prevent abrasive material from entering the fitting during lubrication.
3. Lubricate the Zerk grease fitting with one shot of multipurpose grade grease. Replace the Zerk grease fitting cap when finished.
4. Repeat steps 1–3 for the grease fitting on the remaining pitch adjustment lever.

Pitch Tower (Every 6 Months)

Perform the following lubrication procedure **once every 6 months**.

1. Locate the Zerk grease fitting just below the pitch adjustment lever on either pitch tower (Figure 29). Remove the Zerk grease fitting cap and set it aside.

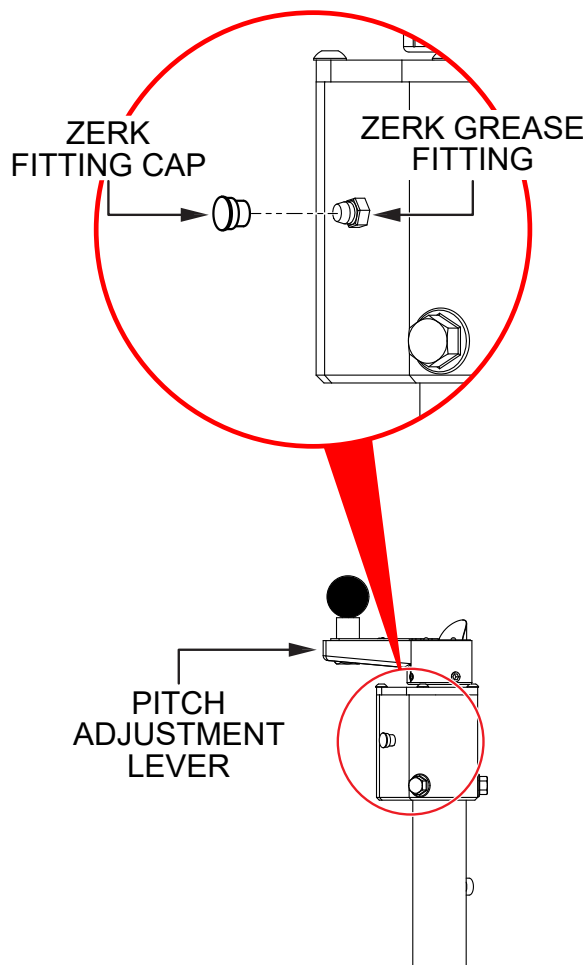

Figure 29. Pitch Tower Lubrication

2. Wipe the Zerk grease fitting clean to prevent abrasive material from entering the fitting during lubrication.
3. Lubricate the Zerk grease fitting with one shot of multipurpose grade grease. Replace the Zerk grease fitting cap when finished.
4. Repeat steps 1–3 for the grease fitting on the remaining pitch tower.

Blade Pitch

Matching Blade Pitch for Both Sets of Blades

Sometimes it may be necessary to match blade pitch between the two sets of blades. There are some signs that this may be necessary. For example, the difference in pitch could cause a noticeable difference in finish quality between the two sets of blades, or make the machine difficult to control. This is due to the surface area in contact with the concrete—the blade set with the greater contact area tends to stick to the concrete more.

Single Pitch

On a Single Pitch trowel, each spider assembly is pitched individually, forcing the operator to constantly make adjustments on each pitch tower.

Twin Pitch™

Trowels equipped with Twin Pitch™ controls may have blade pitch synchronized between the two sets of blades. Blade pitch synchronization is easily accomplished by performing the following procedure. Refer to Figure 30.

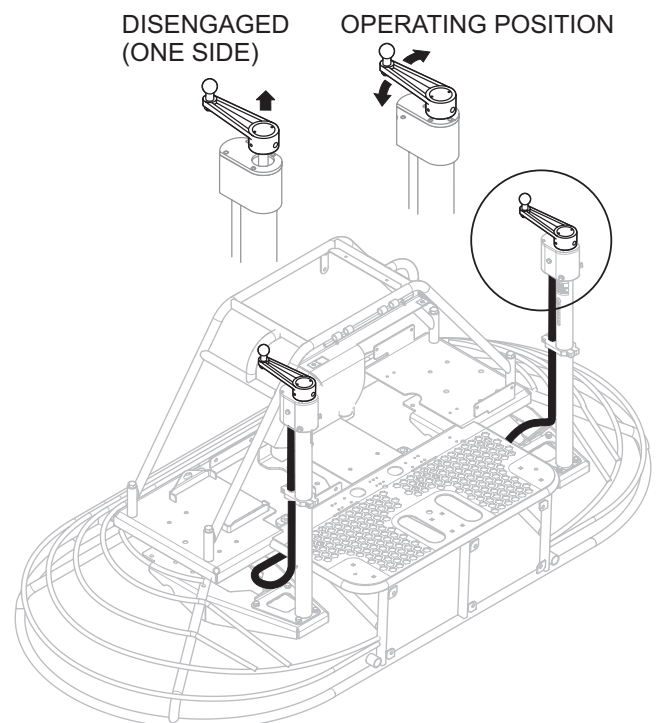

Figure 30. Pitch Towers

1. Lift the pitch adjustment handle on either side. Once lifted, that side is now disconnected from the Twin Pitch™ system.

2. Adjust to match the opposite side.
3. When adjusted, lower the handle to the Twin Pitch™ operating position.

Blade Pitch Adjustment Procedure

Maintenance adjustment of blade pitch is made by adjusting a bolt (Figure 31) on the arm of the trowel blade finger. This bolt is the contact point of the trowel arm with the lower wear plate on the thrust collar. The goal of adjustment is to promote consistent blade pitch and finishing quality.

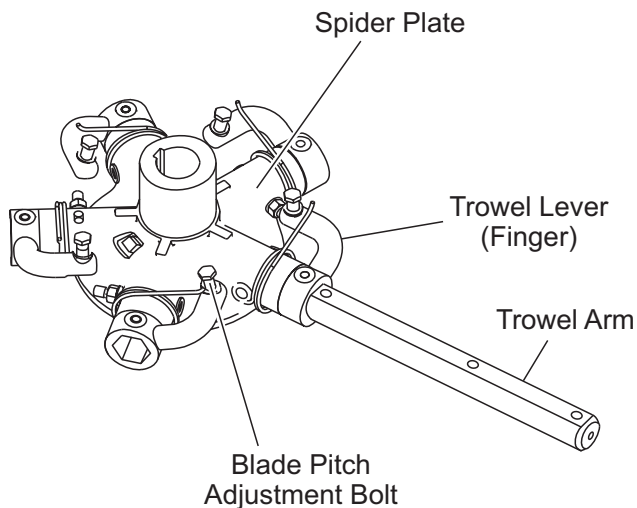

Figure 31. Blade Pitch Adjustment Bolt

Look for the following indications if blades are wearing unevenly. If so, adjustment may be necessary.

- Is one blade completely worn out while the others look new?
- Does the machine have a perceptible rolling or bouncing motion when in use?
- Does the guard ring rock up and down while the machine is running?
- Do the pitch control towers rock back and forth?

The easiest and most consistent way to make adjustments on the trowel arm fingers is to use the trowel arm adjustment tool (P/N 9177). It comes with all the hardware necessary to properly perform this maintenance and instructions on how to utilize this tool.

If a trowel arm adjustment fixture is not available and immediate adjustment is necessary, temporary field adjustment can be made—if you can see or feel which blade is pulling harder—by adjusting the bolt that corresponds to that blade.

A better way to determine which blades need adjustment is to place the machine on a known flat surface (e.g. a steel plate) and pitch the blades as flat as possible. Look at the adjustment bolts. They should all barely make contact with the lower wear plate on the spider. If you can see that one of them is not making contact, some adjustment will be necessary.

Adjust the “high” bolts down to the level of the one that is not touching, or adjust the “low” bolt up to the level of the higher ones. If possible, adjust the low bolt up to the level of the rest of the bolts. This is the fastest way, but may not always work. Verify after adjustment that the blades pitch correctly.

Blades that are incorrectly adjusted often will not be able to pitch flat. This can occur if the adjusting bolts are raised too high. Conversely, adjusting bolts that are too low will not allow the blades to be pitched high enough for finishing operations.

If the machine is still finishing poorly after blade pitch adjustments have been made, the blades, trowel arms, and trowel arm bushings should be checked for adjustment, wear, or damage. See the following sections.

Changing Blades

It is recommended that **ALL** of the blades on the entire machine are changed at the same time. If only one or some of the blades are changed, the machine may wobble or bounce and will not finish concrete consistently.

1. Place the machine on a flat, level surface. Adjust the blade pitch control to pitch the blades as flat as possible. Note the blade orientation on the trowel arm. This is important for ride-on trowels as the two sets of blades counter-rotate. Lift the machine up, placing blocks under the main guard ring to support it.
2. Remove the bolts and lock washers on the trowel arm, then remove the blade.
3. Scrape all concrete and debris from the trowel arm. This is important to properly seat the new blade.
4. Install the new blade, maintaining the proper orientation for direction of rotation.
5. Reinstall the bolts and lock washers.
6. Repeat steps 2–5 for all remaining blades.

Cleanup

Never allow concrete to harden on the power trowel. Wash all concrete off the trowel with water immediately after use. Be careful to not spray a hot engine or muffler. An old paint brush or broom may help loosen any concrete that has started to harden.

Trowel Arm Adjustment Procedure

NOTICE

The following procedure should be performed to adjust trowel arms when it becomes apparent that the trowel is finishing poorly or in need of routine maintenance.

A level, clean area to test the trowel prior to and after adjustment is essential. Any unlevel spots in the floor or debris under the trowel blades will give an incorrect perception of adjustment. Ideally, a 5' x 5', 3/4 inch-thick, flat, steel plate should be used for testing.

1. To determine which blades need adjustment, place the trowel in the test area (3/4 inch-thick plate) and look for the following conditions:
 - Pitch the blades as flat as possible and look at the adjustment bolts. They should all barely make contact with the lower wear plate on the spider. If you can see that one of them is not making contact, some adjustment will be necessary.
 - Are blades wearing out unevenly (e.g. one blade is completely worn out while the others look new)?

Figure 32 illustrates worn spider bushings or bent trowel arms. Check to see that the adjustment bolt is barely touching (0.10" max. clearance) the lower wear plate. All alignment bolts should be spaced the same distance from the lower wear plate.

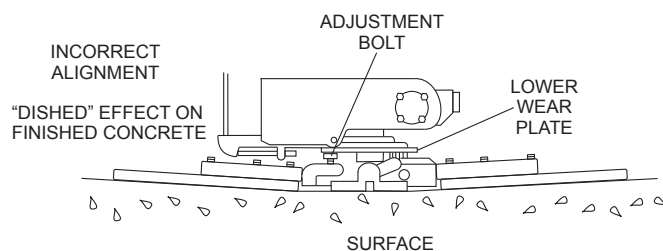

Figure 32. Incorrect Spider Plate Alignment

Figure 33 illustrates the correct alignment for a spider plate (as shipped from the factory).

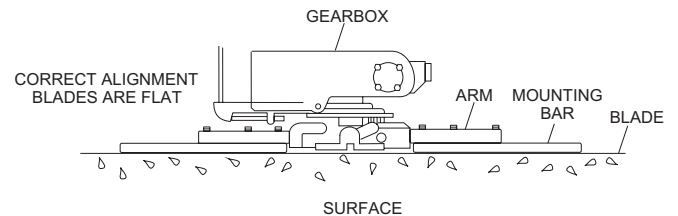

Figure 33. Correct Spider Plate Alignment

2. Start the engine, bring the trowel blades up to full speed, and look for the following conditions:
 - Does the machine have a perceptible rolling or bouncing motion?
 - Does the guard ring rock up and down?

Trowel Blade Removal

1. Remove the trowel blades from the trowel arm by removing the three hex head bolts (Figure 34) from the trowel arm. Set the blades aside.

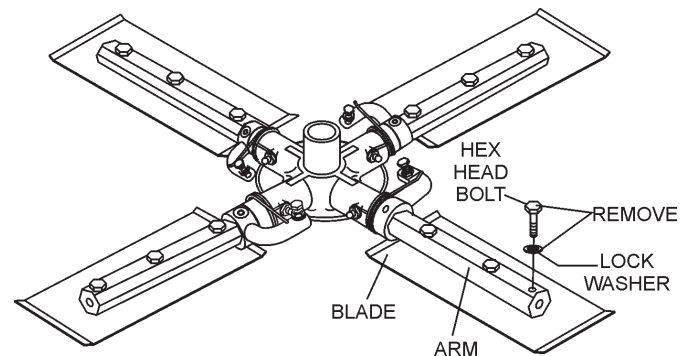

Figure 34. Trowel Blades

2. Wire brush any buildup of concrete from all six sides of the trowel arm. Repeat this for the remaining three arms.

Trowel Arm Removal

1. Each trowel arm is held in place at the spider plate by a hex head bolt (with Zerk grease fitting). Remove the hex head bolt/Zerk grease fitting from the spider plate. (Figure 35).

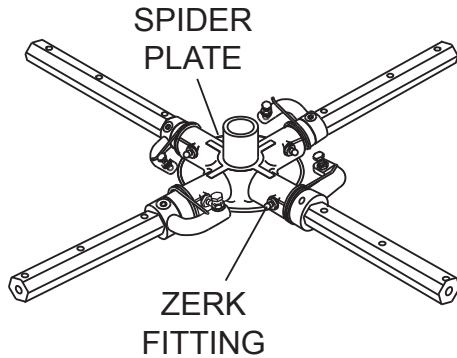

Figure 35. Zerk Grease Fitting Removal

2. Remove the trowel arm from the spider plate.
3. Should the trowel arm insert (bronze bushing) come out with the trowel arm, remove the bushing from the trowel arm and set it aside in a safe place. If the bushing is retained inside the spider plate, carefully remove the bushing.
4. Examine the bronze trowel arm bushing insert (Figure 36), and clean if necessary. Replace the bushing if out-of-round or worn.

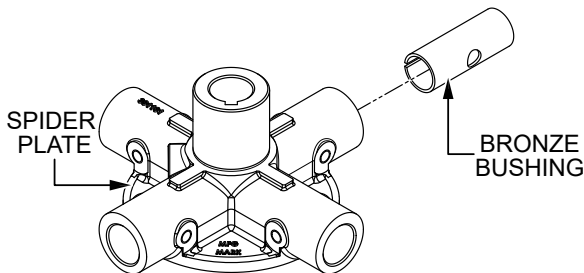

Figure 36. Bronze Bushing

Checking Trowel Arm Straightness

Trowel arms can be damaged by rough handling (such as dropping the trowel on the pad), or by striking exposed plumbing, forms, or rebar while in operation. A bent trowel arm will prevent smooth, fluid rotation of the blades. If bent trowel arms are suspected, check for straightness as follows. Refer to Figure 37 and Figure 38.

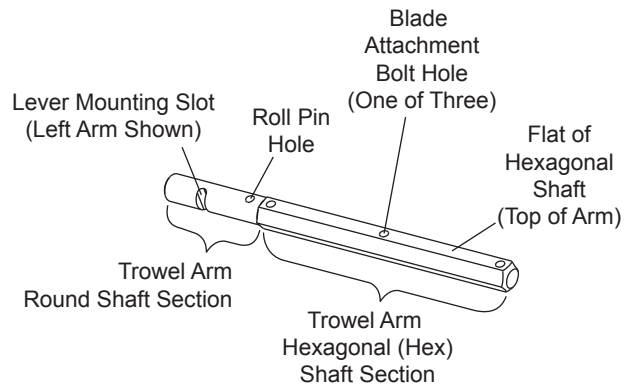

Figure 37. Trowel Arm

1. Use a thick steel plate, granite slab, or any other surface which is true and flat, to check all six sides of each trowel arm for straightness.
2. Check each of the six sides of the trowel arm hex section. A feeler gauge of .004 inch (0.10 mm) should not pass between the flat of the trowel arm and the test surface along its length on the test surface. (Figure 38).

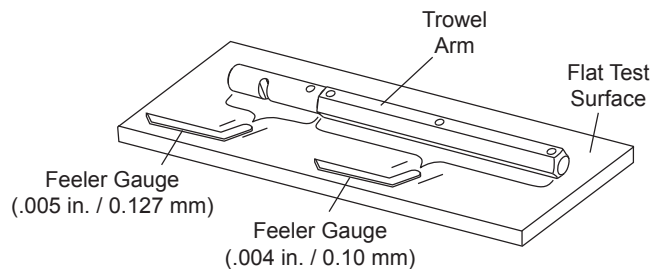

Figure 38. Checking Trowel Arm Straightness

3. Check the clearance between the round shaft and the test surface as one of the flat hex sections of the arm rests on the test surface. Rotate the arm to each of the flat hex sections and check the clearance of the round shaft. Use a feeler gauge of .005 inch (0.127 mm). Each section should have the same clearance between the round of the trowel arm shaft and the test surface.
4. Replace the trowel arm if it is bent or uneven.

Trowel Arm Adjustment

1. Locate the trowel arm adjustment tool (P/N 9177). See Figure 39.

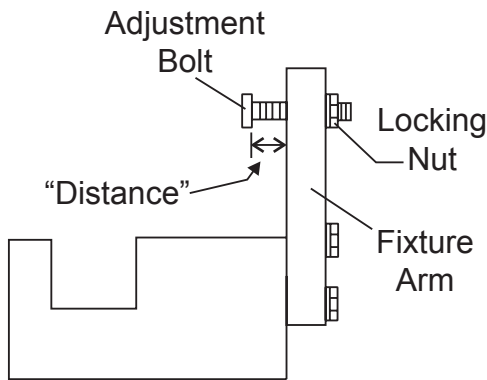

Figure 39. Trowel Arm Adjustment Tool (Side View)

2. Place the fixture arm in the correct position (up or down) for the trowel arm's direction of rotation.

For trowel arms with **clockwise** blade rotation, place the fixture arm in the **UP** position (Figure 40A). For trowel arms with **counterclockwise** blade rotation, place the fixture arm in the **DOWN** position (Figure 40B).

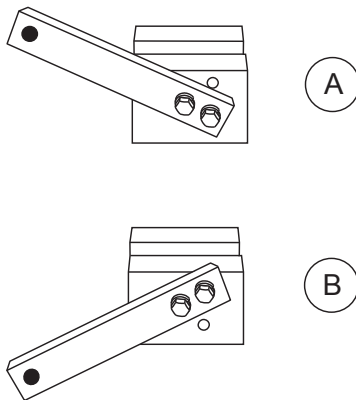

Figure 40. Trowel Arm Adjustment Setup

3. Figure 41 illustrates the adjustment tool with a trowel arm inserted. As each trowel arm is locked into the tool, the arm bolt is adjusted to where it contacts a stop on the fixture. This will consistently adjust all of the trowel arms, keeping the finisher as flat and evenly pitched as possible.

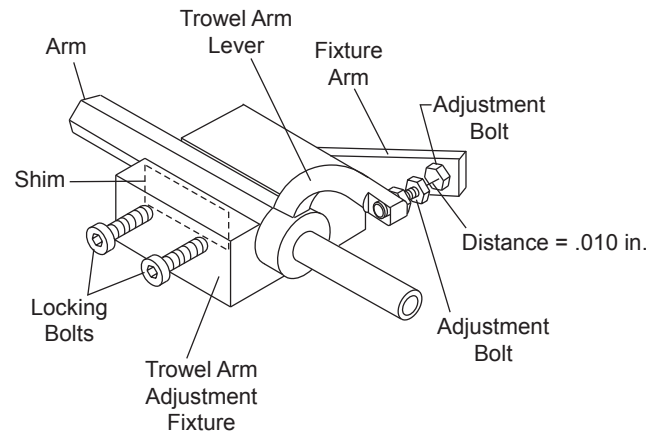

Figure 41. Trowel Arm Adjustment Fixture Components

4. Unscrew the locking bolts on the adjustment tool and place the trowel arm into the fixture channel as shown in Figure 41. A thin shim may be required to cover the blade holes on the trowel arm. Make sure to align the trowel adjustment bolt with the fixture adjustment bolt.
5. Use an Allen wrench to tighten the locking bolts securing the trowel arm in place.
6. Adjust the bolt "distance" shown in Figure 41 to match one of the arms. The other arms will be adjusted to match this distance.
7. Loosen the locking nut on the trowel arm lever, then turn the trowel arm adjusting bolt until it barely touches (.010") the fixture adjusting bolt.
8. Once the correct adjustment is made, tighten the lock nut on the trowel arm to lock it in place.
9. Loosen the locking nuts on the adjustment fixture and remove the trowel arm.
10. Repeat steps for the remaining trowel arms.

Reassembly

1. Clean and examine the upper/lower wear plates and thrust collar. Examine the entire spider assembly. Wire brush any concrete or rust buildup. If any of the spider components are found to be damaged or out-of-round, replace them.
2. Make sure that the bronze trowel arm bushing is not damaged or out-of-round. Clean the bushing if necessary. If the bronze bushing is damaged or worn, replace it.
3. Reinstall the bronze bushing onto the trowel arm.
4. Repeat steps 2–3 for each trowel arm.
5. Make sure that the spring tensioner is in the correct position to exert tension on the trowel arm.
6. Insert all trowel arms with levers into the spider plate (with bronze bushings already installed), using care to align the grease hole on the bronze bushings with the grease hole fittings on the spider plate.
7. Lock the trowel arms in place by tightening the hex head bolts with Zerk grease fittings and jam nuts.
8. Reinstall the blades onto the trowel arms.
9. Install the stabilizer ring onto the spider assembly.
10. Lubricate all grease points (Zerk fittings) with premium Lithium 12-based grease, conforming to NLG1 Grade #2 consistency.

FLOAT PAN INSTALLATION

WARNING



Lifting/crush hazard.

NEVER lift the trowel with pans attached.

WARNING

ALWAYS install pans either in the work area or in an area that is next to and level with the work area.

NEVER lift the trowel while the pans are attached.

Float pans attach to the spider arms and allow early floating on wet concrete and easy movement from wet to dry areas. They are also very effective at embedding large aggregates and surface hardeners.

Refer to Figure 42 when installing pans onto finisher blades.

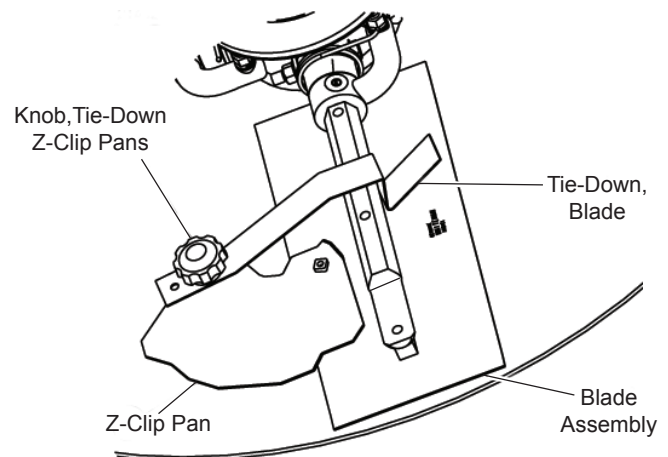

Figure 42. Z-Clip Finisher Pan Installation

1. Lift the trowel just enough to slide the pan under the blades. Lower the finisher onto the pan with the blades adjacent to the Z-clips.
2. Rotate the blades into position under the Z-clips. Ensure that the blades are rotated in the same direction of travel as when the machine is in operation, or use the engine to rotate the blades into position.
3. Attach the blade tie-downs to the far side of the Z-clip brackets with the tie-down knobs as shown in Figure 42.
4. Make sure the blade edges are secured under the Z-clips and the tie-downs are secured completely over the edges of the blade bar before the machine is put back into operation.

LONG-TERM STORAGE

- Remove the battery.
- Drain the fuel from the fuel tank, fuel line, and carburetor.
- Remove the spark plug and pour a few drops of motor oil into the cylinder. Crank the engine 3–4 times so that oil reaches all internal parts.
- Clean the exterior with a cloth soaked in clean oil.
- Cover the unit with a plastic sheet and store it in a moisture- and dust-free location out of direct sunlight.

CAUTION

NEVER store the ride-on trowel with fuel in the tank for an extended period of time. **ALWAYS** clean up spilled fuel immediately.

TROWEL DECOMMISSIONING

Decommissioning is a controlled process used to safely retire a piece of equipment that is no longer serviceable. If the equipment poses an unacceptable and unrepairable safety risk due to wear or damage, or is no longer cost effective to maintain (beyond life cycle reliability) and is to be decommissioned (demolition and dismantlement), the following procedure must be performed:

1. Drain all fluids completely. These may include oil, gasoline, hydraulic oil, and antifreeze. Dispose of fluids properly in accordance with local and governmental regulations. **NEVER** pour fluids on the ground or down drains or sewers.
2. Remove the battery and bring it to an appropriate facility for lead reclamation. Use safety precautions when handling batteries that contain sulfuric acid. Refer to the **Setup** section).
3. The remainder can be brought to a salvage yard or metal reclamation facility for further dismantling.

WIRING DIAGRAM

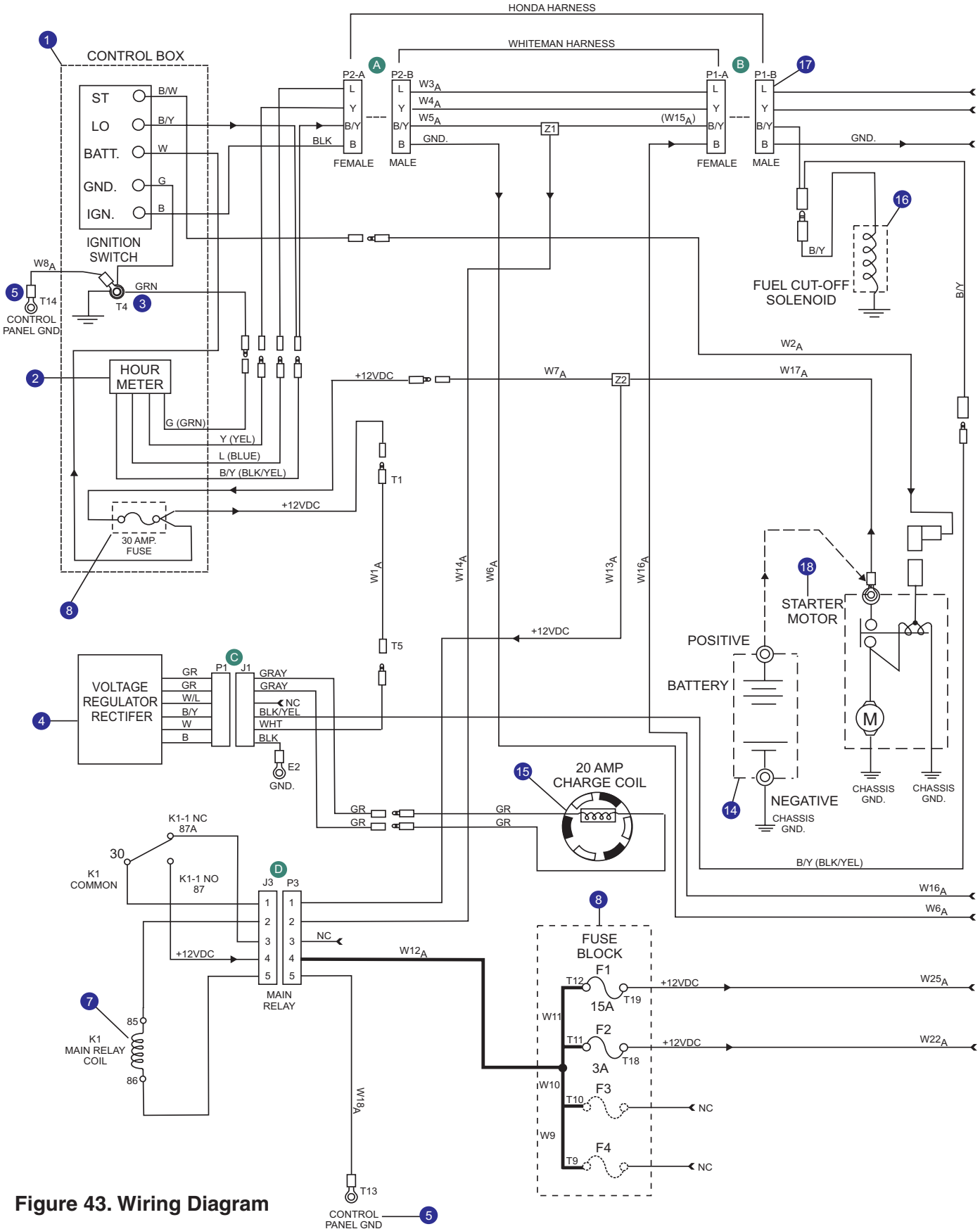
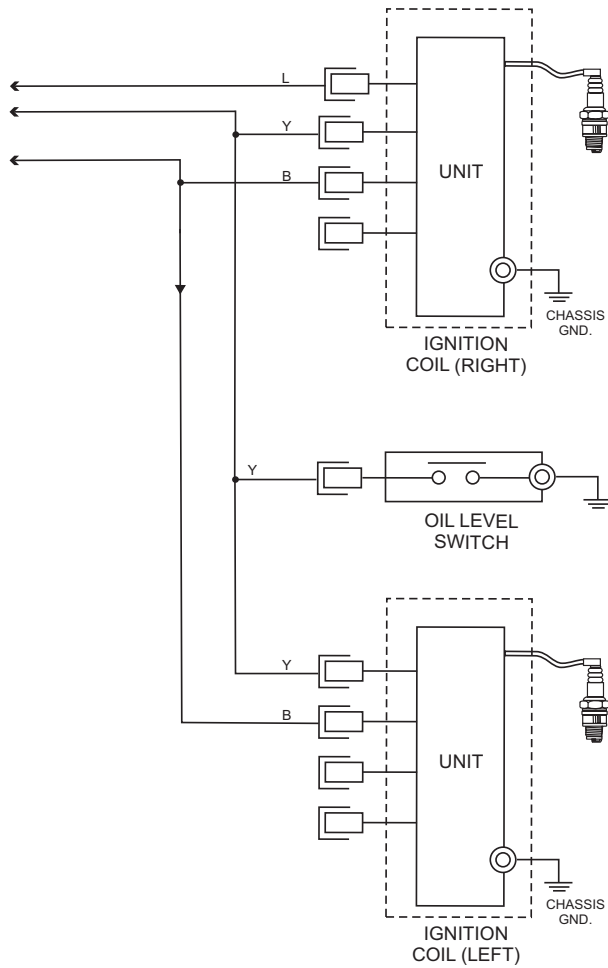

Figure 43. Wiring Diagram

WIRING DIAGRAM



HARNESS DWG.	WIRE REF.	COLOR BODY/STRIPE	WIRE GAGE
23540	W1A	WHITE	16 AWG
	W2A	BLACK/WHITE	16 AWG
	W3A	BLUE	18 AWG
	W4A	YELLOW	18 AWG
	W5A	BLACK/YELLOW	18 AWG
	W6A	BLACK/ORANGE	16 AWG
	W7A	RED	16 AWG
	W8A	BLACK	16 AWG
	W9A	RED	16 AWG
	W10A	RED	16 AWG
	W11A	RED	16 AWG
	W12A	RED	12 AWG
	W13A	RED	12 AWG
	W14A	BLACK/YELLOW	16 AWG
	W15A	BLACK/YELLOW	18 AWG
	W16A	BLACK/ORANGE	18 AWG
	W17A	RED	12 AWG
	W18A	BLACK	16 AWG
	W19A	BLACK	12 AWG
	W20A	BLACK/YELLOW	16 AWG
	W21A	BLACK/GREEN	16 AWG
	W22A	RED/GREEN	16 AWG
	W23A	BLACK/YELLOW	16 AWG
	W24A	BLACK/YELLOW	16 AWG
	W25A	BLACK/YELLOW	16 AWG
	W26A	RED/YELLOW	16 AWG
	W27A	RED/YELLOW	16 AWG
	W28A	RED/YELLOW	16 AWG
23541	W1B	BLACK/ORANGE	16 AWG
	W2B	BLACK/ORANGE	16 AWG
	W3B	RED YELLOW	16 AWG
	W4B	BLACK/YELLOW	16 AWG
23542	W1C	RED/YELLOW	16 AWG
	W6C	BLACK/YELLOW	16 AWG
	W3C	RED/GREEN	16 AWG
	W4C	BLACK/GREEN	16 AWG
	W5C	RED/YELLOW	16 AWG
	W6C	BLACK/YELLOW	16 AWG
	W7C	RED	16 AWG
	W8C	RED/YELLOW	16 AWG
	W9C	RED/GREEN	16 AWG

	IG	E	BAT	LO	ST
OFF					
ON	○—○	○—○	○—○	○—○	
ST	○—○	○—○	○—○	○—○	○—○

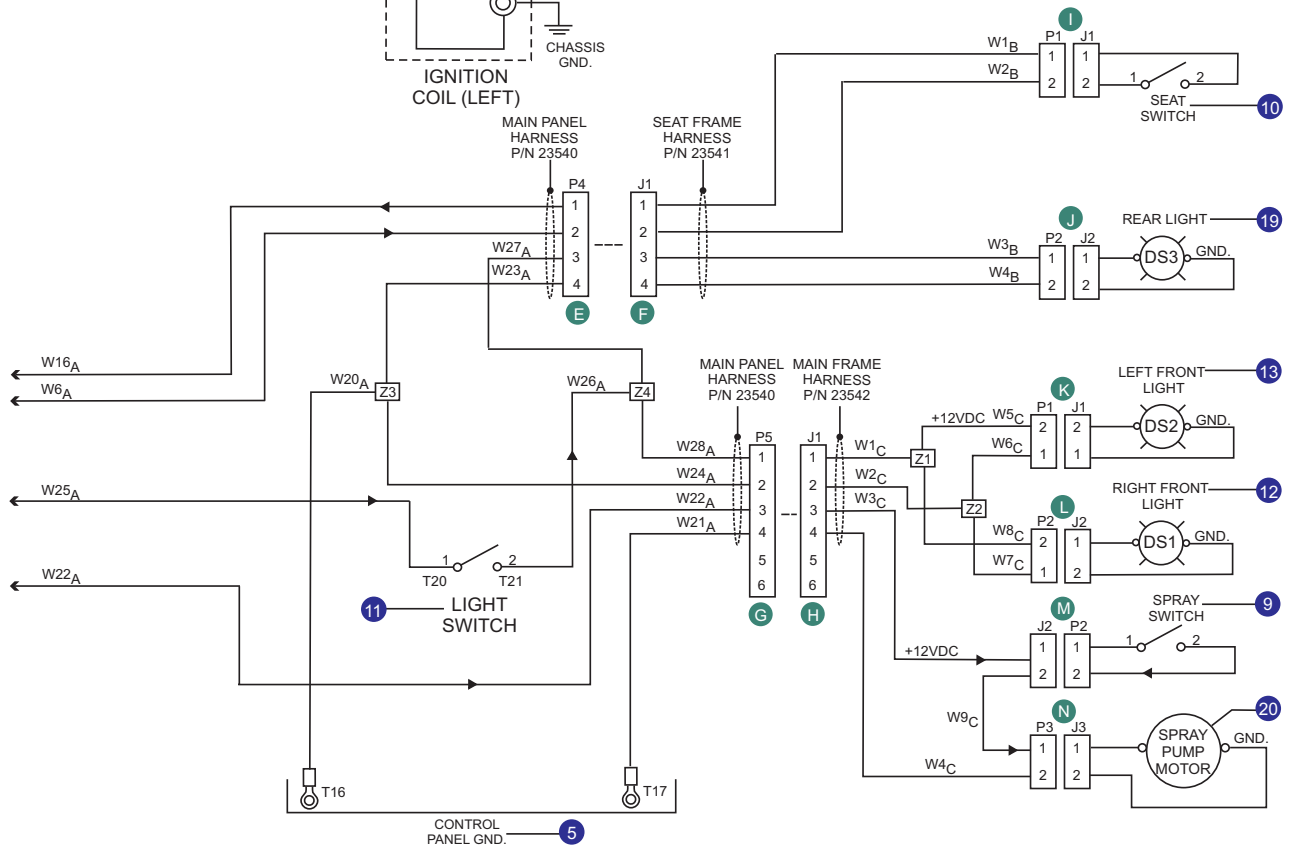

WIRING DIAGRAM COMPONENT LOCATOR

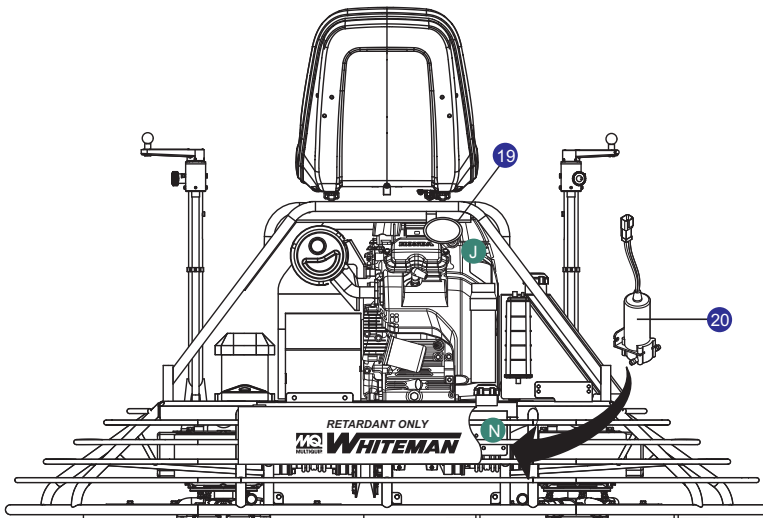
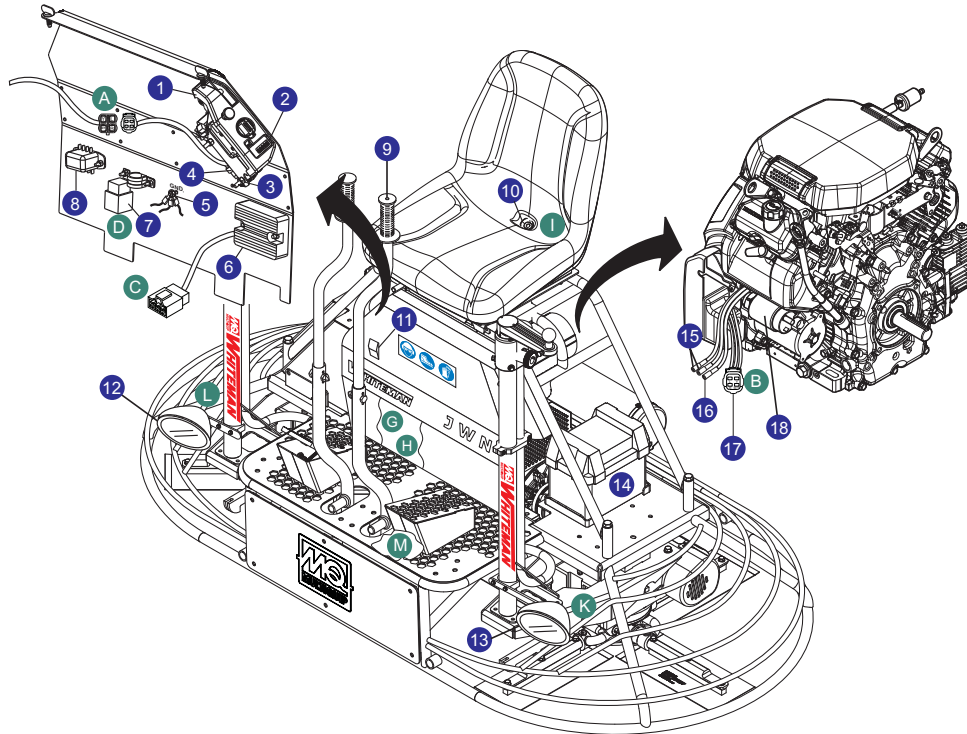

REF. DES.	CONNECTOR	FUNCTION
A		ENGINE INTERFACE CTRL. BOX SIDE
B		ENGINE INTERFACE ENGINE SIDE
C		VOLTAGE REGULATOR/RECTIFIER
D		MAIN RELAY
E		MAIN PANEL HARNESS P/N 23540 (P4) MATES WITH SEAT FRAME HARNESS P/N 23541 (J1)
F		SEAT FRAME HARNESS P/N 23541 (J1) MATES WITH MAIN PANEL HARNESS P/N 23540 (P4)
G		MAIN PANEL HARNESS P/N 23540 (P5) MATES WITH MAIN FRAME HARNESS P/N 23542 (J1)
H		MAIN FRAME HARNESS P/N 23542 (J1) MATES WITH MAIN PANEL HARNESS P/N 23540 (P5)
I		SEAT SWITCH
J		REAR LIGHT
K		LEFT FRONT LIGHT
L		RIGHT FRONT LIGHT
M		SPRAY SWITCH
N		SPRAY PUMP MOTOR

NOTES:



REFERENCE DESIGNATORS E THRU F NOT SHOWN.
LOCATION MUST BE TRACED THROUGH HARNESS.

Figure 44. Wiring Component Locator

TROUBLESHOOTING

Troubleshooting (Engine)		
Symptom	Possible Problem	Solution
Difficult to start, fuel is available, but no spark at spark plug.	Spark plug bridging?	Check gap, insulation or replace spark plug.
	Carbon deposit on spark plug?	Clean or replace spark plug.
	Short circuit due to deficient spark plug insulation?	Check spark plug insulation, replace if worn.
	Improper spark plug gap?	Set to proper gap.
	Spark plug is red?	Check transistor ignition unit.
	Spark plug is bluish white?	If insufficient compression, repair or replace engine. If injected air leaking, correct leak. If carburetor jets clogged, clean carburetor.
	No spark present at tip of spark plug?	Check if transistor ignition unit is broken, and replace defective unit. Check if voltage cord cracked or broken and replace. Check if spark plug is fouled and replace.
	No oil?	Add oil as required.
	Oil pressure alarm lamp blinks upon starting? (if applicable)	Check automatic shutdown circuit, oil sensor. (if applicable)
Difficult to start, fuel is available, and spark is present at the spark plug.	ON/OFF switch is shorted?	Check switch wiring, replace switch.
	Ignition coil defective?	Replace ignition coil.
	Improper spark gap, points dirty?	Set correct spark gap and clean points.
	Condenser insulation worn or short circuiting?	Replace condenser.
	Spark plug wire broken or short circuiting?	Replace defective spark plug wiring.
Difficult to start, fuel is available, spark is present and compression is normal.	Wrong fuel type?	Flush fuel system, replace with correct type of fuel.
	Water or dust in fuel system?	Flush fuel system.
	Air cleaner dirty?	Clean or replace air cleaner.
	Choke open?	Close choke.
Difficult to start, fuel is available, spark is present and compression is low.	Suction/exhaust valve stuck or protruded?	Reseat valves.
	Piston ring and/or cylinder worn?	Replace piston rings and/or piston.
	Cylinder head and/or spark plug not tightened properly?	Torque cylinder head bolts and spark plug.
	Head gasket and/or spark plug gasket damaged?	Replace head and spark plug gaskets.
No fuel present at carburetor.	No fuel in fuel tank?	Fill with correct type of fuel.
	Fuel cock does not open properly?	Apply lubricant to loosen fuel cock lever, replace if necessary.
	Fuel filter/lines clogged?	Replace fuel filter.
	Fuel tank cap breather hole clogged?	Clean or replace fuel tank cap.
	Air in fuel line?	Bleed fuel line.

TROUBLESHOOTING

Troubleshooting (Engine) - continued		
Symptom	Possible Problem	Solution
Weak in power, compression is proper and does not misfire.	Air cleaner dirty?	Clean or replace air cleaner.
	Improper level in carburetor?	Check float adjustment, rebuild carburetor.
	Defective spark plug?	Clean or replace spark plug.
	Improper spark plug?	Set to proper gap.
Weak in power, compression is proper but misfires.	Water in fuel system?	Flush fuel system and replace with correct type of fuel.
	Dirty spark plug?	Clean or replace spark plug.
	Ignition coil defective?	Replace ignition coil.
Engine overheats.	Wrong type of fuel?	Replace with correct type of fuel.
	Cooling fins dirty?	Clean cooling fins.
	Intake air restricted?	Clear intake of dirt and debris. Replace air cleaner elements as necessary.
	Oil level too low or too high?	Adjust oil to proper level.
Rotational speed fluctuates.	Governor adjusted incorrectly?	Adjust governor.
	Governor spring defective?	Replace governor spring.
	Fuel flow restricted?	Check entire fuel system for leaks or clogs.
Recoil starter malfunctions. (if applicable)	Recoil mechanism clogged with dust and dirt?	Clean recoil assembly with soap and water.
	Spiral spring loose?	Replace spiral spring.
Starter malfunctions.	Loose, damaged wiring?	Ensure tight, clean connections on battery and starter.
	Battery insufficiently charged?	Recharge or replace battery.
	Starter damaged or internally shorted?	Replace starter.
Burns too much fuel.	Over-accumulation of exhaust products?	Check and clean valves. Check muffler and replace if necessary.
	Wrong spark plug?	Replace spark plug with manufacturer's suggested type.
Exhaust color is continuously white.	Lubricating oil is wrong viscosity?	Replace lubricating oil with correct viscosity.
	Worn rings?	Replace rings.
Exhaust color is continuously black.	Air cleaner clogged?	Clean or replace air cleaner.
	Choke valve set to incorrect position?	Adjust choke valve to correct position.
	Carburetor defective, seal on carburetor broken?	Replace carburetor or seal.
	Poor carburetor adjustment, engine runs too rich?	Adjust carburetor.
Will not start, no power with key ON. (if applicable)	ON/OFF device not activated ON?	Turn on ON/OFF device.
	Battery disconnected or discharged?	Check cable connections. Charge or replace battery.
	Ignition switch/wiring defective?	Replace ignition switch. Check wiring.

TROUBLESHOOTING

Troubleshooting (Ride-On Mechanical Trowel)		
Symptom	Possible Problem	Solution
Engine running rough or not at all.	Stop switch malfunction?	Make sure that the stop switch is functioning when the operator is seated. Replace switch if necessary.
	Fuel?	Look at the fuel system. Make sure there is fuel being supplied to the engine. Check to ensure that the fuel filter is not clogged.
	Ignition?	Check to ensure that the ignition switch has power and is functioning correctly.
Safety stop switch not functioning.	Bad contacts?	Replace switch.
	Loose wire connections?	Check wiring. Replace as necessary.
	Other problems?	Consult engine manufacturer's manual.
Trowel bounces, rolls concrete, or makes uneven swirls in concrete.	Blades?	Make sure blades are in good condition, not excessively worn. Finish blades should measure no less than 2 inches (50mm) from the blade bar to the trailing edge, combo blades should measure no less than 3.5 inches (89mm). Trailing edge of blade should be straight and parallel to the blade bar.
	Pitch Adjustment?	Check that all blades are set at the same pitch angle as measured at the spider. A field adjustment tool is available for height adjustment of the trowel arms (contact Parts Department).
	Bent trowel arms?	Check the spider assembly for bent trowel arms. If one of the arms is even slightly bent, replace it immediately.
	Trowel arm bushings?	Check the trowel arm bushings for tightness. This can be done by moving the trowel arms up and down. If there is more than 1/8 inch (3.2 mm) of travel at the tip of the arm, the bushings should be replaced. All bushings should be replaced at the same time.
	Thrust collar?	Check the flatness of the thrust collar by rotating it on the spider. If it varies by more than 0.02 inch (0.5 mm) replace the thrust collar.
	Thrust collar bushing?	Check the thrust collar by rocking it on the spider. If it can tilt more than 1/16 inch (1.6 mm) - as measured at the thrust collar O.D., replace the bushing in the thrust collar.
	Thrust bearing worn?	Check the thrust bearing to see that it is spinning freely. Replace if necessary.
Machine has a perceptible rolling motion while running.	Main shaft?	The main output shaft of the gearbox assembly should be checked for straightness. The main shaft must run straight and cannot be more than 0.003 inch (0.08 mm) out of round at the spider attachment point.
	Yoke?	Check to make sure that both fingers of the yoke press evenly on the wear cap. Replace yoke as necessary.
	Blade Pitch?	Check to ensure that each blade is adjusted to have the same pitch as all other blades. Adjust per maintenance section in manual.

TROUBLESHOOTING

Troubleshooting (Ride-On Mechanical Trowel) - continued		
Symptom	Possible Problem	Solution
Lights (optional) not working.	Wiring?	Check all electrical connections in the lighting circuit. Verify wiring is in good condition with no shorts. Replace defective wiring or components immediately.
	Lights?	If +12VDC is present at light fixture connector when light switch is activated and light does not turn on, replace light bulb.
	Bad switch?	Check the continuity of light switch. Replace light switch if defective.
	Bad fuse?	Check fuse. Replace fuse if defective.
Retardant spray (optional) not working.	Retardant?	Check retardant level in tank. Fill tank as required.
	Wiring?	Check all electrical connections in the spray pump circuit. Verify wiring is in good condition with no shorts. Replace defective wiring or components immediately.
	Bad switch?	Check the continuity of both left and right spray switches (palm handles). Replace spray switch if defective..
	Bad spray pump?	If +12VDC is present at pump connector when spray switch is activated and pump does not operate, replace spray pump.
	Bad fuse?	Check fuse. Replace fuse if defective.
Steering is unresponsive.	Blade speed out of adjustment?	See section on blade speed adjustment.
	Steering linkage out of adjustment?	Adjust the connecting linkage found at the base of the handle. Contact your MQ field service manager for instructions.
	Worn components?	Check for wear of steering bearings and linkage components. Replace if necessary.
Operating position is uncomfortable.	Seat adjusted for operator?	Adjust seat with lever located on the front of the seat.
Power head on Electric Pitch (optional) not working.	Broken or loose parts?	If the motor runs and the pitch is not affected, parts inside the power head may be loose or broken. Return power head to dealer for service.
	Wiring?	Check all electrical connections and wiring. Check the continuity at the power head unit. Verify that there is voltage present at the power head switch with the key switch in the "on" position.
	Switch?	Check the continuity of the switch. If switch is malfunctioning, replace immediately.
Linkage on Twin Pitch not working.	Crank handles?	Make sure that both crank handles are pushed down as far as possible to ensure that the linkage is engaged.
	Broken part?	Replace all broken parts immediately.
Clutch slipping or sluggish response to engine speed change.	Worn belts?	Replace belt.
	Clutch out of adjustment?	Adjust per instructions in maintenance section of this manual.
	Worn or defective clutch parts?	Replace parts as necessary.
	Worn bearings in gearbox?	Rotate input shaft by hand. If shaft rotates with difficulty, check the input and output shaft bearings. Replace as necessary.
	Worn or broken gears in gearbox?	Verify that the gearbox shaft rotates when the input shaft is rotated. Replace both the worm and worm gear as a set.

OPERATION MANUAL

HERE'S HOW TO GET HELP

PLEASE HAVE THE MODEL AND SERIAL
NUMBER ON-HAND WHEN CALLING

UNITED STATES

Multiquip Inc.

(310) 537- 3700
6141 Katella Avenue Suite 200
Cypress, CA 90630
E-MAIL: mq@multiquip.com
WEBSITE: www.multiquip.com

CANADA

Multiquip

(450) 625-2244
4110 Industriel Boul.
Laval, Quebec, Canada H7L 6V3
E-MAIL: infocanada@multiquip.com

UNITED KINGDOM

Multiquip (UK) Limited Head Office

0161 339 2223
Unit 2, Northpoint Industrial Estate,
Globe Lane,
Dukinfield, Cheshire SK16 4UJ
E-MAIL: sales@multiquip.co.uk

© COPYRIGHT 2022, MULTIQUIP INC.

Multiquip Inc, the MQ logo are registered trademarks of Multiquip Inc. and may not be used, reproduced, or altered without written permission. All other trademarks are the property of their respective owners and used with permission.

This manual MUST accompany the equipment at all times. This manual is considered a permanent part of the equipment and should remain with the unit if resold.

The information and specifications included in this publication were in effect at the time of approval for printing. Illustrations, descriptions, references and technical data contained in this manual are for guidance only and may not be considered as binding. Multiquip Inc. reserves the right to discontinue or change specifications, design or the information published in this publication at any time without notice and without incurring any obligations.

Your Local Dealer is:



PN: 23624



Flextool

1956 Dandenong Road, Clayton VIC 3168, Australia

Phone (AUS): 1300 353 986

flextool.com.au

ABN 80 069 961 968

This manual summarises our best knowledge of the product based on the information available at the time of publication. You should read this manual carefully and consider the information in the context of how the product will be used. Our responsibility for products sold is subject to our standard terms and conditions of sale.

DISCLAIMER:

Any advice, recommendation, information, assistance or service provided by us in this manual is given in good faith and is believed by us to be appropriate and reliable. However, any advice, recommendation, information, assistance or service provided by us is provided without liability or responsibility PROVIDED THAT the foregoing shall not exclude, limit, restrict or modify the right entitlements and remedies conferred upon any person or the liabilities imposed upon us by any condition or warranty implied by Commonwealth, State or Territory Act or ordinance void or prohibiting such exclusion limitation or modification. The product can be expected to perform as indicated in this manual so long as operation and operational procedures of the individual products are followed as recommended in this manual.

Design and technical specifications may be subject to changes.

© This publication is copyright. All rights are reserved. Flextool is a registered trade mark of Parchem Construction Supplies Pty Ltd. Multiquip, MQ and Whiteman are registered trade marks of Multiquip Inc.